

GM Steering Wheel Button Box Installation Guide

Rev. 1.2

© 2019, 2021 Accutach Co.

www.accutach.com

Thank you for purchasing the Accutach Co. General Motors Steering Wheel Button Box. It is designed to allow you to repurpose the audio and/or cruise control buttons on your stock GM steering wheel to control other accessories. Supported GM cars include: 1997-2001 Camaro, 1995-2002 Firebird, 2007-2013 Corvettes, 2010-2015 Camaros and other GM cars, trucks and SUVs of those vintages. See the list of known compatible cars in the following sections of this document. This box may be compatible with other models of GM vehicles.



WARNINGS and DISCLAIMERS:

You use this product at your own risk. Accutach Company is not responsible for personal injury or property damage through the use of this product. While it is possible to use a switch in the steering wheel control wire to switch the steering wheel button function from radio/cruise control to accessory control and back again, Accutach Company strongly recommends that users permanently change the button functions from radio/cruise control to control of your accessory. If you choose to use a switch against our recommendations be careful make sure you know how the switch is set prior to pressing any steering wheel button. You'd hate to activate a line lock at road speeds while trying to adjust the radio for example.

Do not touch the air bag wiring as you modify the radio control wiring near the steering column. Make sure you disconnect the battery before doing any electrical work described in this installation guide and follow the air bag safety recommendations in the GM shop manual.

We strongly recommend making wire connections with solder & shrink tubing, although properly made crimp splices can also be reliable. We do not recommend using "Scotch Lock" style connections for our products. Do not use the "twist & tape" method of connecting wires.

Before you begin:

You will need to identify a switched battery voltage power supply wire to splice into for power for the Steering Wheel Button Box, and you will need a good chassis ground to ground the unit.

You will also need to locate a suitable place to install the unit inside of the vehicle's cabin, most likely under the dash or in the console near the shifter. It is not intended for use in the engine compartment or anywhere outside of the cabin. If you wish to create a custom mounting bracket out of ABS plastic you can glue it to the ABS box with standard ABS cement from a hardware store.

Before you begin (Cont.):

You will need to read the service manual for your vehicle to learn how to safely disable the air bag system. Failure to properly disable the air bag system could lead to injury or death if the air bag accidentally deploys while you are installing the steering wheel button box.

You will need to locate the steering wheel power and signal wires coming down from the clockspring mechanism for your car. Here are the wire colors for some of the more popular GM vehicles. If your car is not on this list, you will need to contact Accutach Co..

95-02 Firebird, 97-01 Camaro 92-99 Bonneville 98-99 Riviera Power: YEL Signal: DK BLU	03-06 Chevy Avalanche, 03-06 Chevy Suburban, 03-06 Chevy Tahoe, 03-06 GMC Sierra, 03-06 GMC Yukon, 03-07 Hummer H2, 03-06 Cadillac Escalade Power: DK BLU Signal: LT GRN	
07-13 Corvette Power: PPL/WHT Signal: DK BLU	03-06 Chevy Silverado Power: LT GRN Signal: DK BLU	04-09 Chevy Trailblazer, 05-08 Isuzu Ascender, 04-07 Buick Rainier Power: WHT Signal: LT GRN

10-15 Camaro, 11-16 Cruze, 14-16 Malibu, 11-15 Volt, Power: YEL Signal (Audio): LT GRN Signal (Cruise): GRY	07-13 Chevy Silverado, 07-13 Chevy Avalanche, 07-14 Chevy Suburban, 07-14 Chevy Tahoe, 07-13 GMC Sierra, 07-14 GMC Yukon, 08-09 Hummer H2, 07-14 Cadillac Escalade Power: PNK Signal (Audio): LT GRN Signal (Cruise): GRY	

The Accutach Co. GM Steering Wheel Button Box has 5 modes of operation. One mode repurposes the steering wheel buttons for Firebirds, older Camaros, Corvettes and the other vehicles above without cruise control signals. The remaining 4 modes of operation provide 4 different ways of remapping 8 of the buttons on 2010-2015 Camaros and the other vehicles above with cruise control signals. If your vehicle is not on the lists above, please contact Accutach Co. to see if your GM vehicle is also supported.

You will need to plan your button mapping The GM Steering Wheel Button Box has 8 relays and 8 pairs of colored output wires. After installation, when you press a button on the steering wheel, the relay associated with that button will close, connecting the associated colored wire pair together.

Firebirds, older Camaros and cars with the same steering wheel switches have 8 audio pushbuttons to repurpose, while the Corvettes have 7 audio pushbuttons. You will need to decide which buttons will control which accessories. Accutach Co. also supplies auxiliary toggle and on/off boxes if a simple pushbutton switch action is not adequate for you application.

2010-2015 Camaros and other cars with the same switch modules have 10 buttons and one switch. The cruise control group consists of the switch and 3 buttons. The cruise control ON switch must be set to On for the other cruise control buttons to work. The audio group consists of 7 buttons. The Accutach Co. Steering Wheel Button Box only has 8 relays, so only a subset of the steering wheel functions can be mapped in any mode. Please read the 2010-2015 Camaro operating mode pages so you can decide which button remapping mode you will want to use for your car.

Mode 0: (2010-2015 Camaro, etc.) Right handed

ON switch must be On for the other cruise control buttons to be enabled.

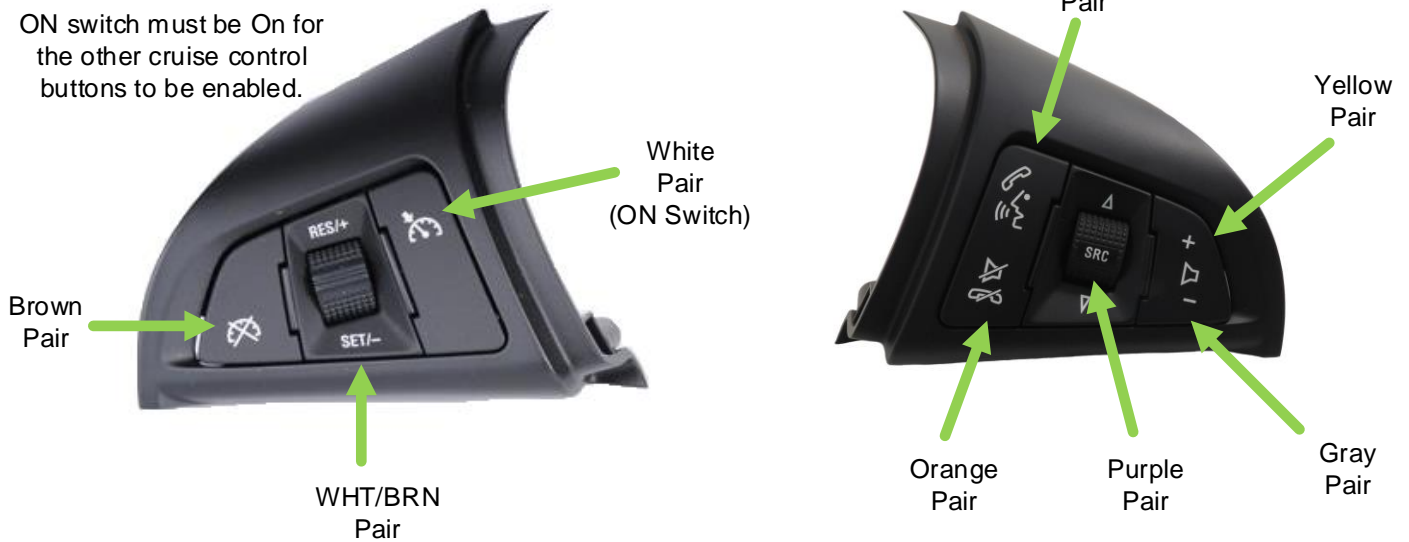

Mode 0 is selected by leaving the WHT/ORN & WHT/BLK wires disconnected. Put shrink tubing over the ends of these wires to ensure they don't accidentally short to anything.

The other vehicles with the cruise control signal have the same buttons but with different functions. The button names are:

Camaro	Suburban, Silverado, Avalanche, Tahoe, Sierra, Yukon, H2, Escalade
VOL+	MUTE
VOL-	VOL-
SEEK+	VOL+
SEEK-	PREVIOUS
SOURCE	NEXT
VOICE	SOURCE
MUTE	SEEK
CANCEL	CANCEL
SET-	SET-
RES+	RES+
ON	ON

Mode 1: (2010-2015 Camaro, etc.) Most right handed mode

Mode 1 is selected by leaving the WHT/BLK wire disconnected. Put shrink tubing over the end of the WHT/BLK wire to ensure it doesn't accidentally short to anything. Ground the WHT/ORN wire.



Mode 2: (2010-2015 Camaro, etc.) Even handed

Mode 2 is selected by leaving the WHT/ORG wire disconnected. Put shrink tubing over the end of the WHT/ORG wire to ensure it doesn't accidentally short to anything. Ground the WHT/BLK wire.



Mode 3: (2010-2015 Camaro, etc.) Right handed

Mode 3 is selected by grounding the WHT/ORN & WHT/BLK wires.

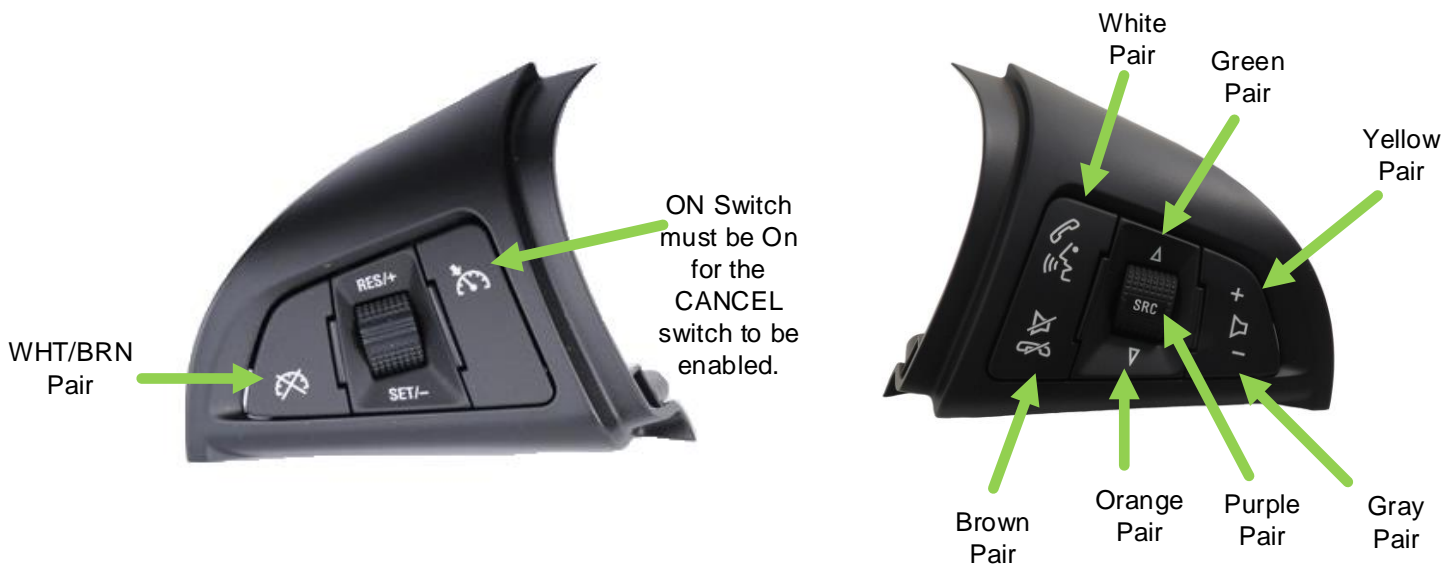

Note that the 2010-2015 Camaro cruise control buttons include an ON switch. That switch is a toggle switch, but it is not a momentary-on switch. When you press the ON switch, it stays on until you press the bottom side of the ON switch, which turns it Off. The other cruise control buttons are enabled only when the ON switch is On. They are disabled when it is Off. The GM Steering Wheel Button Box can detect when the ON button is on or off, so that switch can also control an output.

Mode 4: (1995-2002 Firebird, 1997-2001 Camaro, etc.)

Mode 4 is selected by leaving the WHT/ORN & WHT/BLK wires disconnected. Put shrink tubing over the ends of these wires to ensure they don't accidentally short to anything. Ground the WHT/RED wire.

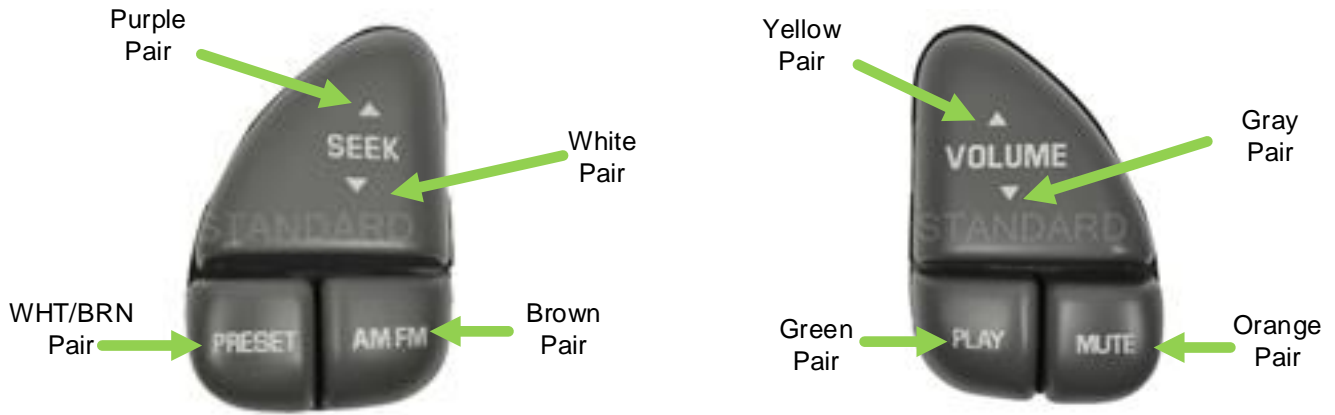

Mode 4: (2007-2013 Corvette)

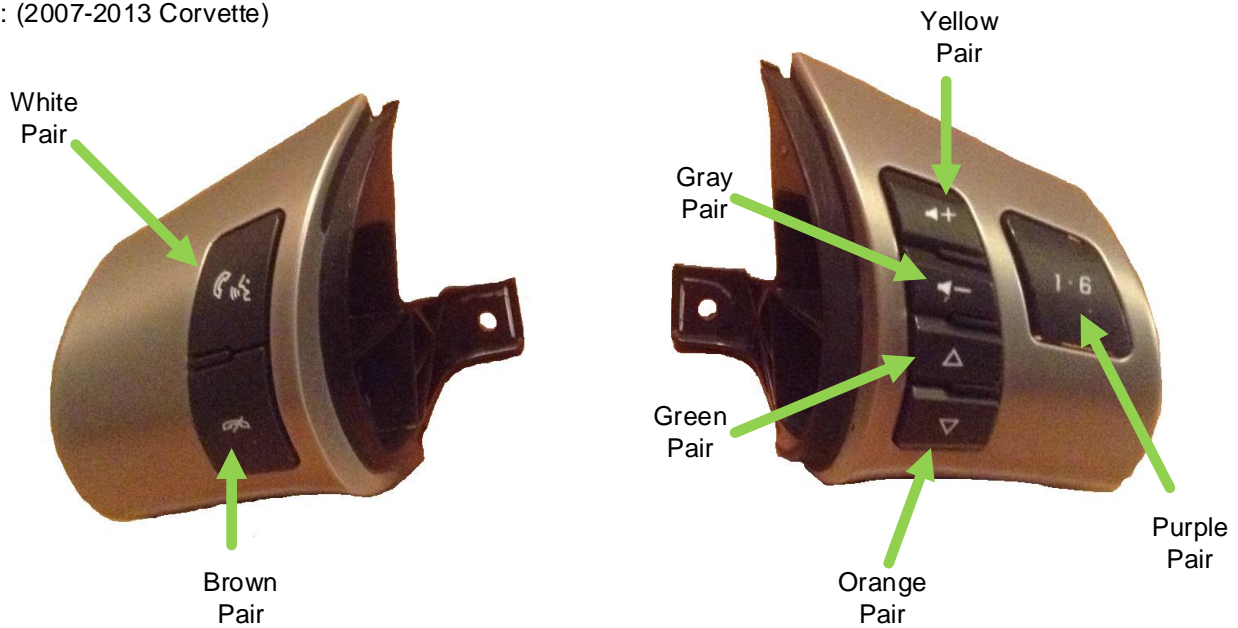

Note that 2007-2008 Corvettes only have the 5 right hand buttons. Also note that not all 2009-2013 Corvettes have the 2 left hand Bluetooth buttons, so Corvettes only have 5 to 7 buttons to repurpose.

The older vehicles without the cruise control signal have the same buttons but with different functions. The button names are:

Camaro, Firebird	Corvette	Silverado, Trailblazer, Suburban, Avalanche, Tahoe, Envoy, Sierra, Yukon	Impala	Century
VOL+	VOL+	VOL+	VOL+	VOL+
VOL-	VOL-	VOL-	VOL-	VOL-
PLAY	NEXT	SEEK+	MODE	SOURCE
MUTE	PREVIOUS	SEEK-	MUTE	MUTE
SEEK+	PRESET 1-6	VOICE	SEEK+	SEEK+
SEEK-	VOICE	PROG	SEEK-	SEEK-
AM/FM	PHONE	SOURCE+	SCAN	SCAN
PRESET		SOURCE-	PRESET	AM/FM

Locating the Radio/Cruise Control Signal Wires

The 07-13 Corvette is shown here as an example. Refer to your vehicle's service manual if you are unsure of how to access the steering column wiring in your vehicle.

You will need to remove the plastic cover under the drivers side dash to gain access to the wiring in the steering column.

The plastic cover under the driver's side dash is held in place with two screws, four clips and two hooks. Remove the two screws using a Torx T10 driver:

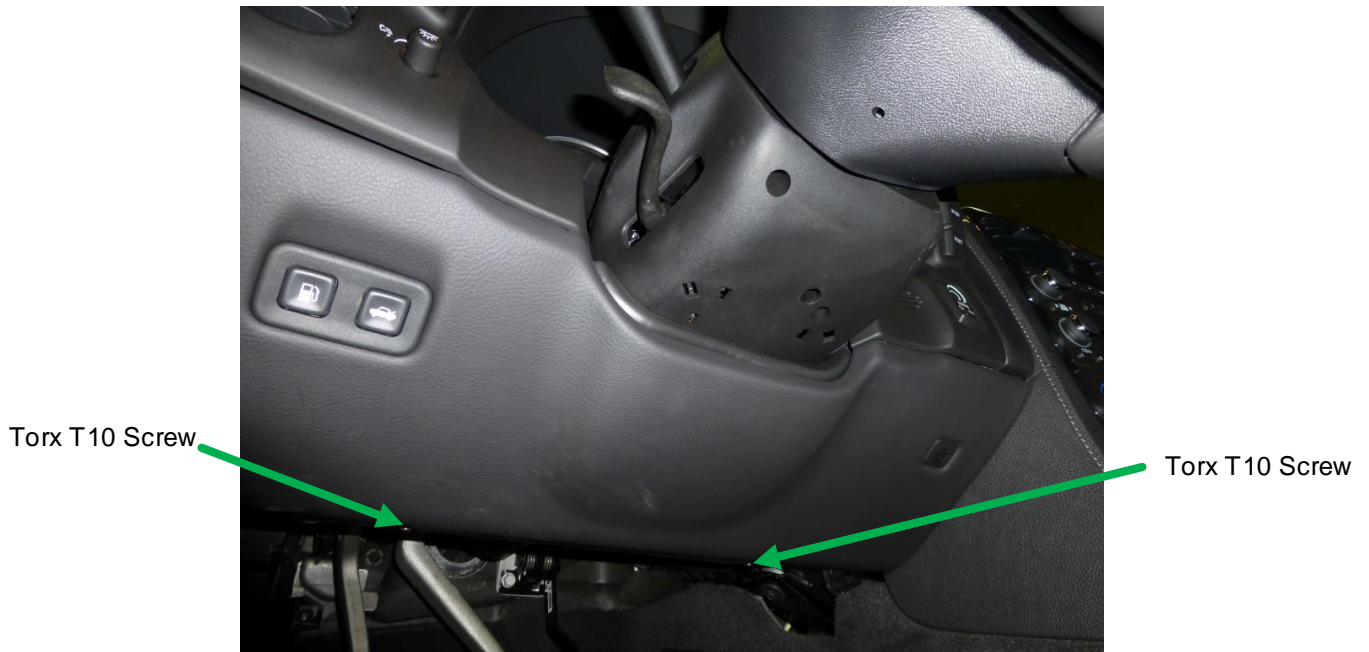

Carefully pull the plastic cover down from the bottom so that it can pivot on the hooks at the top of the panel as the clips disengage. Here is a picture of the clips:



Here is a photo with the panel removed:



Find connector C231 behind the metal panel. Slide it left to release it in order to get access to the steering wheel control signal wire. It should look like this:

Connector
C231

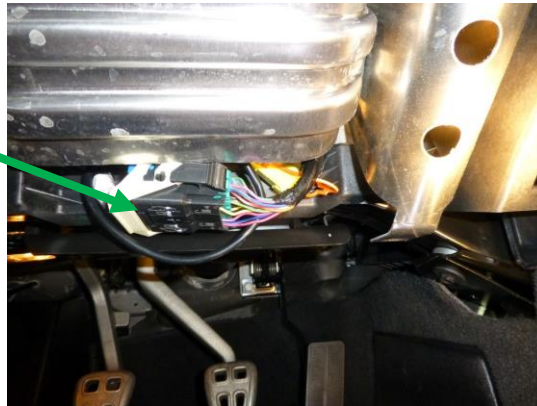

Make sure you DO NOT expose the air bag connector instead.

Carefully get access to the Steering Wheel Control Signal and Radio Control Supply Voltage wires.

95-02 Firebird, 97-01 Camaro, 92-99 Boneville, 98-99 Buick Riviera, etc.

Power: YEL

Signal: DK BLU

05-13 Corvette

Power: PPL/WHT

Signal: DK BLU

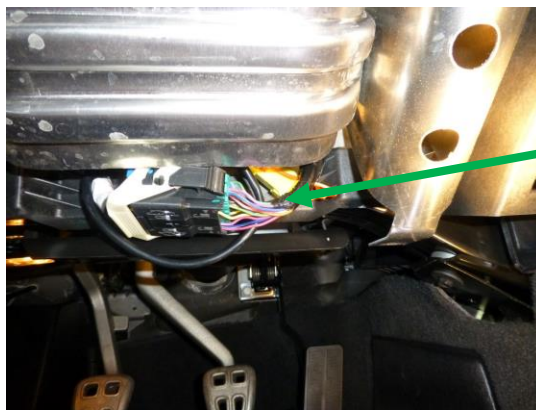

Find the Dark
Blue Steering
Wheel Control
Signal wire
and the
Purple/White
Radio Control
Supply Voltage
wire in a
Corvette

10-15 Camaro, 11-16 Cruze, 14-16 Malibu, 11-15 Volt, etc.

Power: YEL

Signal: LT GRN (Audio)

Signal: GRY (Cruise)

Installing the GM Steering Wheel Button Box

At this point, you should have unhooked the battery and followed the service manual process for disabling the air bag system. If you have not, do that now.

Once you have located the signal and power lines below the clockspring mechanism, cut them both. Make sure that the power wires coming from the audio/cruise control modules are covered with shrink tubing and secured so they can't short to anything including the vehicle body. If a power wire is powered and the power wire shorts out, you may destroy your audio system or your body control module.

This is a good time to test your steering wheel button circuit to make sure it is working properly prior to repurposing.

Put an ohmmeter across the Power and Signal wires going up into the clockspring mechanism. With each button pressed one at a time, you should see resistance values on the ohmmeter that are within 5% of these resistances:

Corvette	97-01 Camaro, 95-02 Firebird, etc.	03-06 Silverado, 04-09 Trailblazer, etc.	00-05 Impala	Resistance
VOL+	VOL+	VOL+	VOL+	1270 Ohms
VOL-	VOL-	VOL-	VOL-	1564 Ohms
NEXT	PLAY	SEEK+	MODE	1912 Ohms
PREVIOUS	MUTE	SEEK-	MUTE	2387 Ohms
PRESET 1-6	SEEK+	VOICE	SEEK+	3102 Ohms
VOICE	SEEK-	PROG	SEEK-	4282 Ohms
PHONE	AM/FM	SOURCE+	SEEK TYPE	6652 Ohms
None	PRESET	SOURCE-	PRESET	13612 Ohms

10-15 Camaro, 11-16 Cruze, 14-16 Malibu, 11-15 Volt Audio Buttons	07-13 Silverado, 07-14 Suburban, 07-14 Tahoe, 07-13 Avalanche, 07-13 Sierra 07-14 Yukon, 08-09 H2, 07-14 Escalade Audio Buttons	Resistance
VOL+	MUTE	1210
VOL-	VOL-	1511
SEEK+	VOL+	1923
SEEK-	PREVIOUS	2410
SOURCE	NEXT	3014
VOICE	SOURCE	3820
MUTE	SEEK	5320

Cruise Buttons	Cruise Buttons	Resistance
OFF	OFF	Open Circuit
ON	ON	6805
RES+	RES+	3795
SET-	SET-	2325
CANCEL	CANCEL	1500

If you don't see resistances near these, debug the steering wheel switches and the wiring from the switches through the clockspring mechanism to the cut wire ends before continuing with the installation.

After you have validated the switches and wiring, splice the Power wire going up into the clockspring mechanism to a wire that you run to the same ground you use for the Steering Wheel Box ground. For the vehicles without cruise control buttons, splice the Blue wire from the Accutach Steering Wheel Button Box to the Signal wire going up into the clockspring mechanism.

For vehicles with cruise control buttons, splice the Blue wire from the Accutach Steering Wheel Button Box to the Audio Signal wire going up into the clockspring mechanism. Splice the WHT/RED wire from the Accutach Steering Wheel Button Box to the Cruise Control Signal wire going up into the clockspring mechanism.

Use shrink tubing to insulate the other side of the power wire that goes to the OEM audio system. Do not leave the OEM audio system in the circuit or the Steering Wheel Button Box will not work.

It is possible to configure the output of the Steering Wheel Button Box to simulate the steering wheel button circuit for some of the buttons. This will allow you to repurpose some of the buttons for custom use while leaving the rest of the buttons with the OEM function. Please contact Accutach Co. for applications assistance if you want to do that.

Accutach Co. strongly recommends that you permanently repurpose your steering wheel buttons. However, it is possible to install a switch that will allow you to switch between "Race Mode" where the steering wheel buttons control your racing accessories and "Street Mode" where your steering wheel buttons control the OEM functions. If you use a switch like this, you do so at your own risk. If you press a button thinking it will control one accessory and another is activated, there is danger of damage to your vehicle, injury or even death. For example, you would not want to activate a transbrake at highway speeds thinking you are activating cruise control. Such an example would have a very bad end.

If you choose to use a switch to retain the use of the radio control function of your vehicle (against our recommendations), then we recommend that you add an extra pole to the switch to add an indicator that lights when you are in Race Mode (Not Included).

Since the Steering Wheel Button Box requires that the common wire to the steering wheel be grounded, you must use a "break-before-make" type of switch. This is due to the fact that you will need to change the OEM Power wire into a ground wire and a "make-before-break" switch will cause a momentary short of power to ground. The switches recommended in this document are break-before-make type.

You will need a 3PDT switch to switch a single group of buttons. If you want to switch both the audio and cruise functions, you will need a 4PDT switch.

Accutach Co. recommends the following switches (Not Included):

3PDT: NKK M2032TYW01-JA, Digikey part number M2032TYW01-JA-ND

4PDT: NKK M2042TNW01-DA, Digikey part number 360-2276-ND

To repurpose one button group, wire a 3PDT switch's common connections to a ground for the Race Mode Indicator, the Power wire and the Signal wire going to the steering wheel. Wire one side of the 3PDT switch to the OEM Power and Signal wires, leaving the indicator not connected. Wire the other side of the 3PDT switch so that the Power wire going to the steering wheel gets connected to ground and the Signal wire going to the steering wheel gets connected to the Steering Wheel Button Box input signal wire:

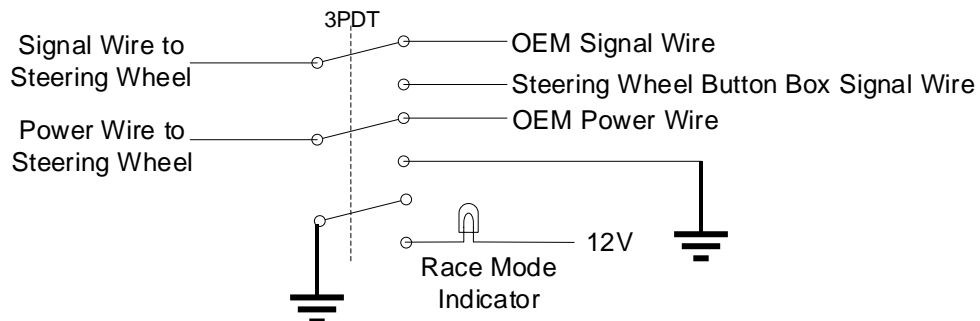

To repurpose one button group, wire a 4PDT switch's common connections to a ground for the Race Mode Indicator, the Power wire and the Signal wire going to the steering wheel. Wire one side of the 4PDT switch to the OEM Power and Signal wires, leaving the indicator not connected. Wire the other side of the 4PDT switch so that the Power wire going to the steering wheel gets connected to ground, the Audio Signal wire going to the steering wheel gets connected to the Steering Wheel Button Box Blue input signal wire and the Cruise Control Signal wire going to the steering wheel gets connected to the Steering Wheel Button Box WHT/RED input signal wire:

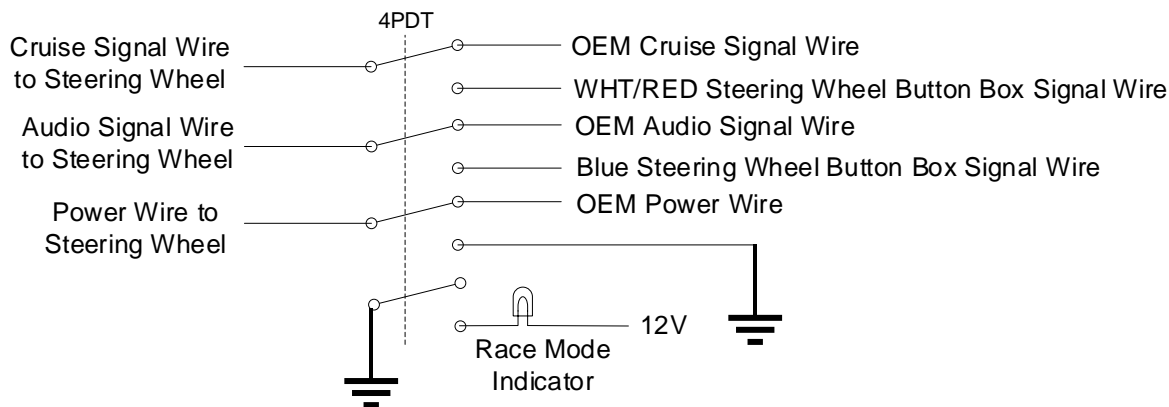

The following section describe how to connect the Accutach Co. Steering Wheel Button Box in a number of popular GM vehicles.

07-13 Corvette (Mode 4)

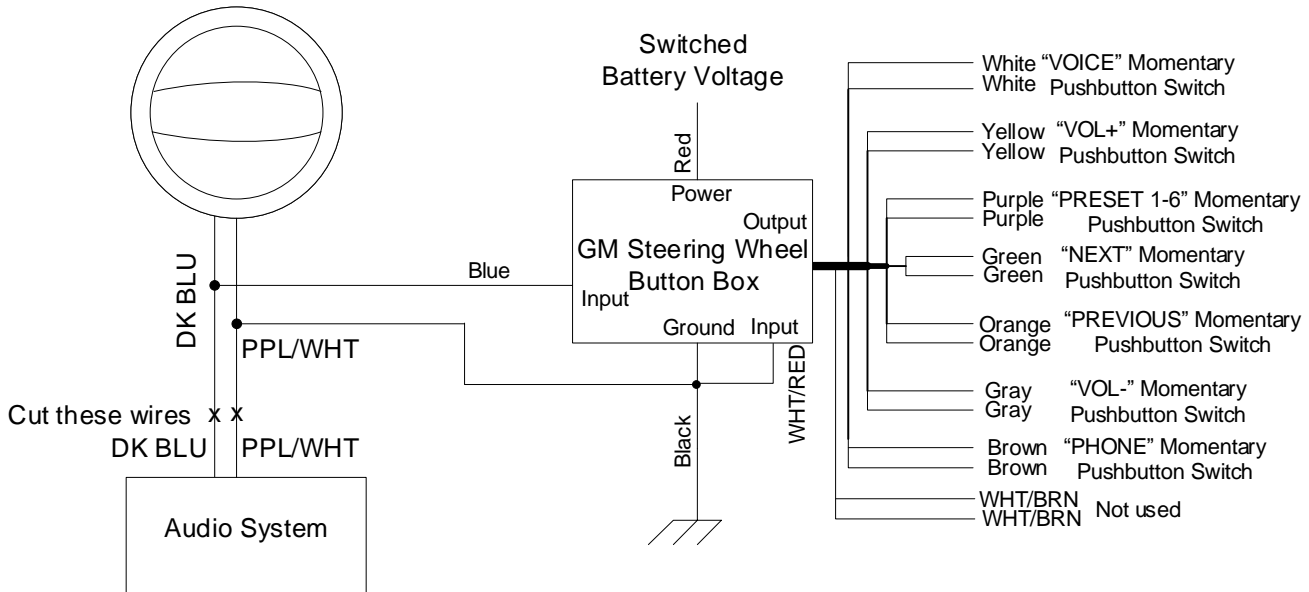

Each Steering Wheel Button Box output is rated to 125V and 1A. Switching of larger signals will require an additional external relay

Here is a schematic diagram of how to connect the Accutach GM Steering Wheel Button Box to a Corvette with a 3PDT switch (Mode 4):

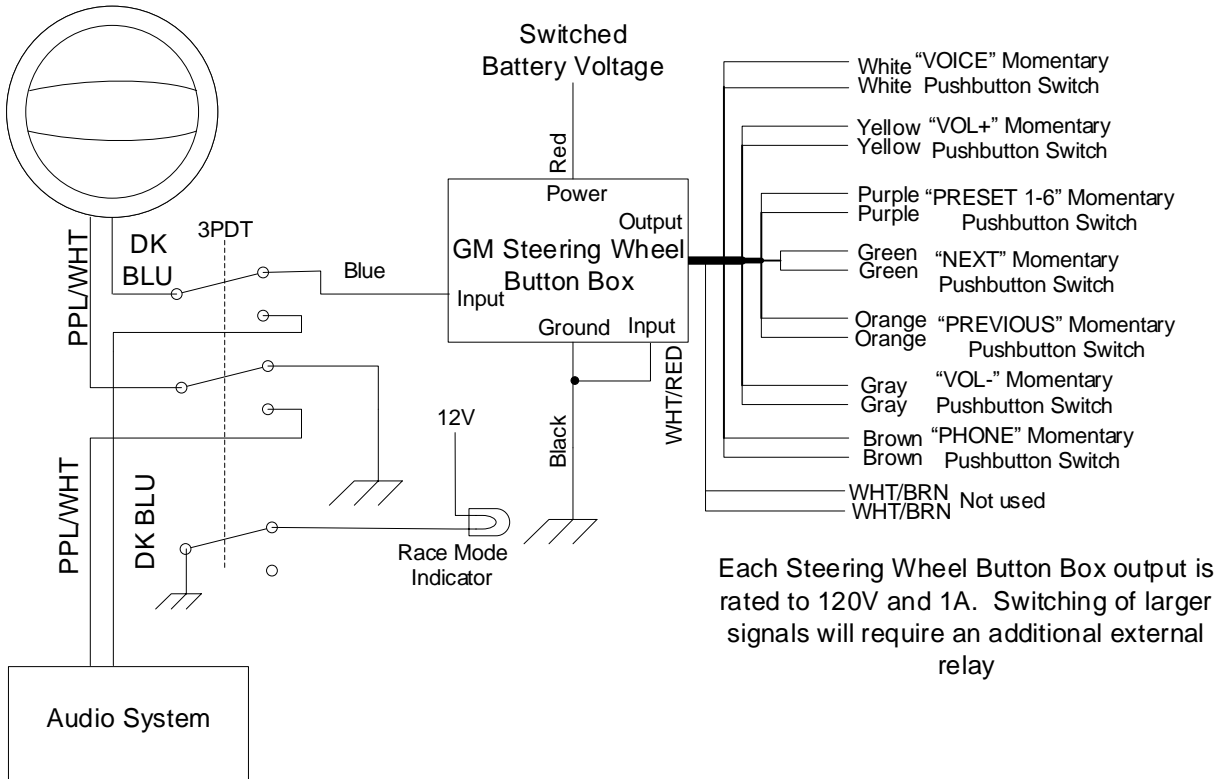

Each Steering Wheel Button Box output is rated to 120V and 1A. Switching of larger signals will require an additional external relay

95-02 Firebird, 97-01 Camaro, 92-99 Bonneville, 98-99 Riviera (Mode 4)

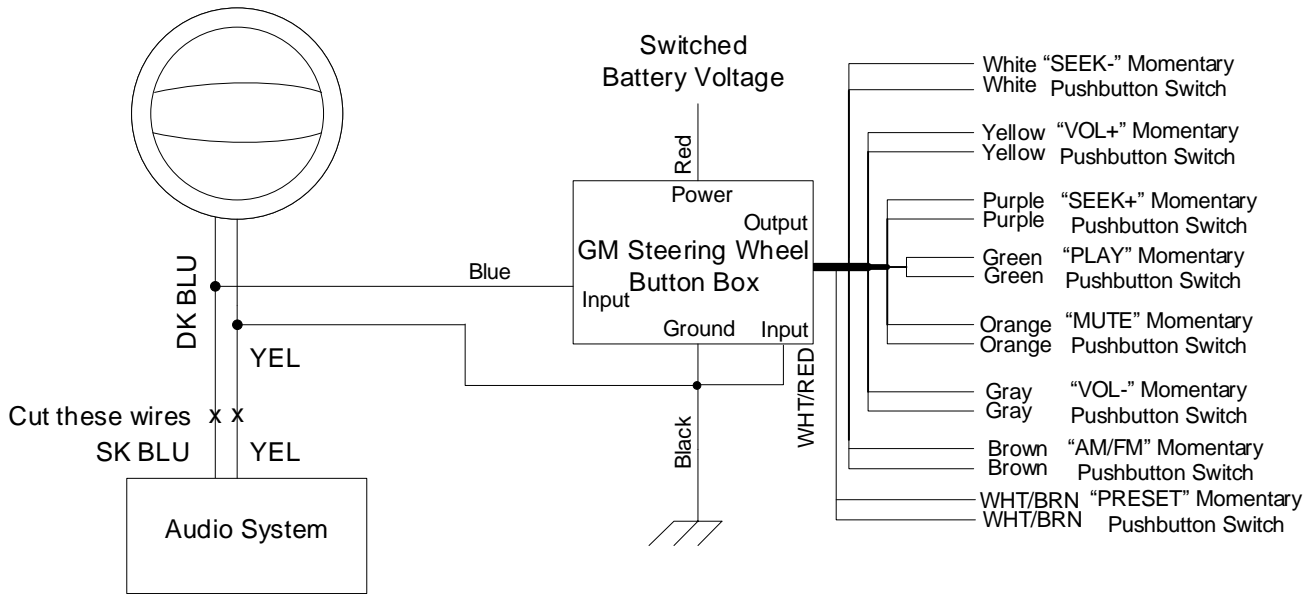

Each Steering Wheel Button Box output is rated to 125V and 1A. Switching of larger signals will require an additional external relay

Here is a schematic diagram of how to connect the Accutach GM Steering Wheel Button Box to an 95-02 Firebird, 97-01 Camaro, 92-99 Bonneville or 98-99 Riviera with a 3PDT switch (Mode 4):

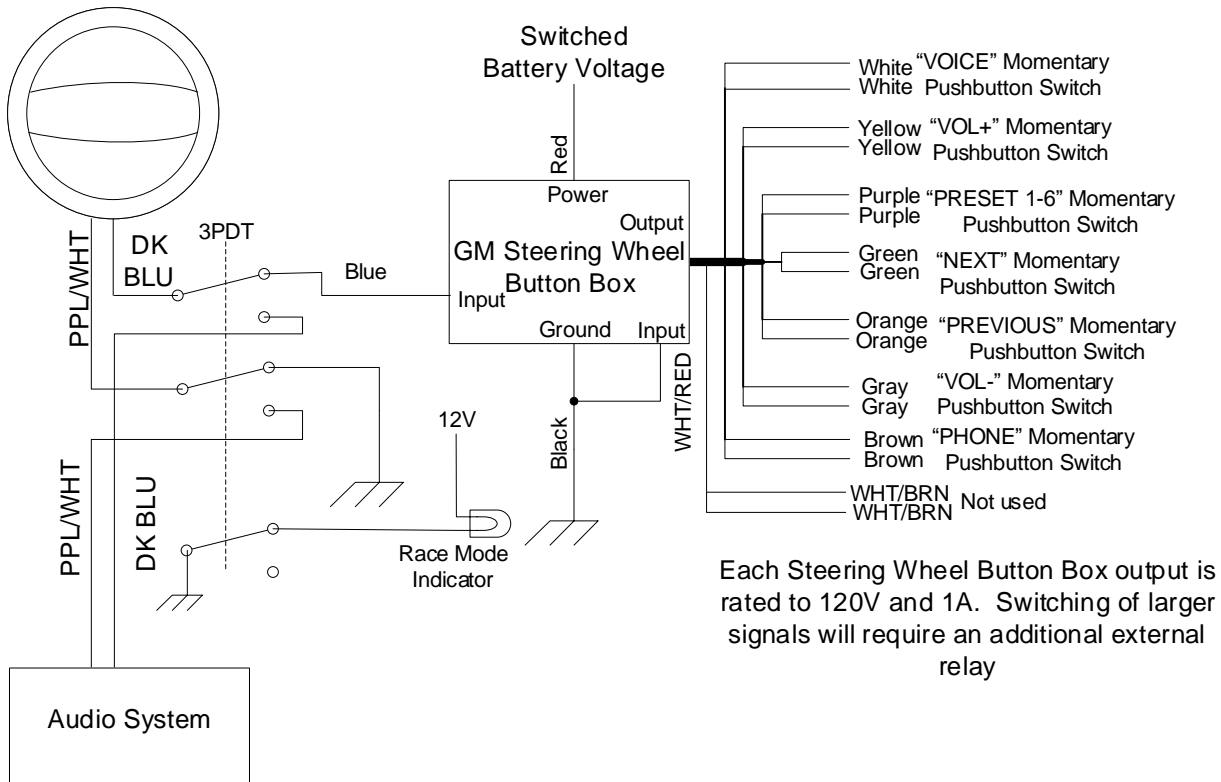

Each Steering Wheel Button Box output is rated to 120V and 1A. Switching of larger signals will require an additional external relay

03-06 Avalanche, 03-06 Suburban, 03-06 Tahoe, 03-06 Sierra, 03-06 Yukon, 03-07 H2, 03-06 Escalade (Mode 4)

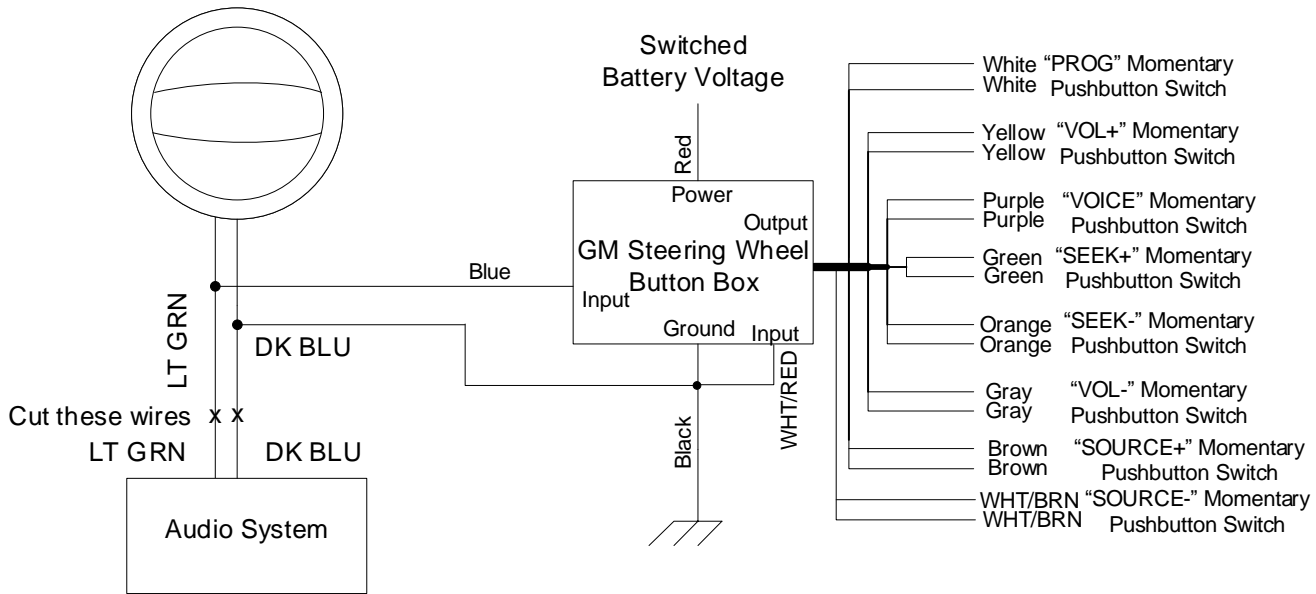

Each Steering Wheel Button Box output is rated to 125V and 1A. Switching of larger signals will require an additional external relay

Here is a schematic diagram of how to connect the Accutach GM Steering Wheel Button Box to an 03-06 Avalanche, 03-06 Suburban, 03-06 Tahoe, 03-06 Sierra, 03-06 Yukon, 03-07 H2 or 03-06 Escalade with a 3PDT switch (Mode 4):

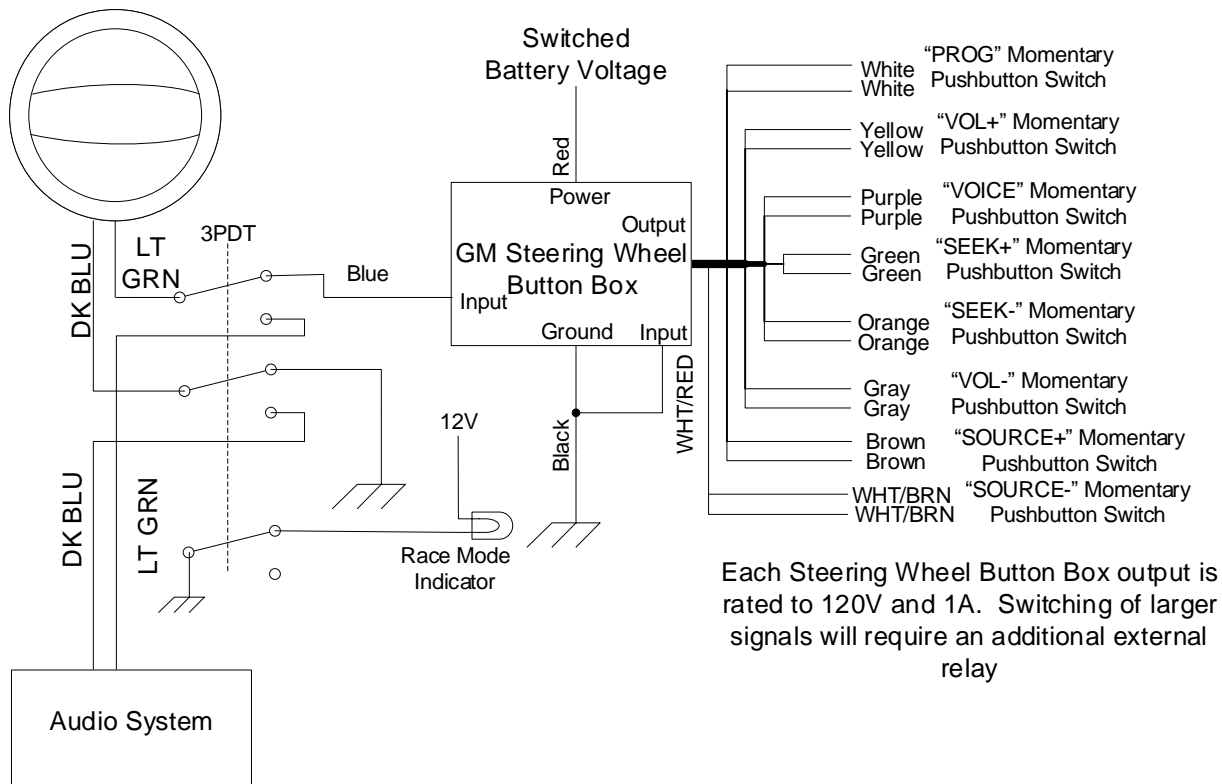

Each Steering Wheel Button Box output is rated to 120V and 1A. Switching of larger signals will require an additional external relay

03-06 Silverado (Mode 4)

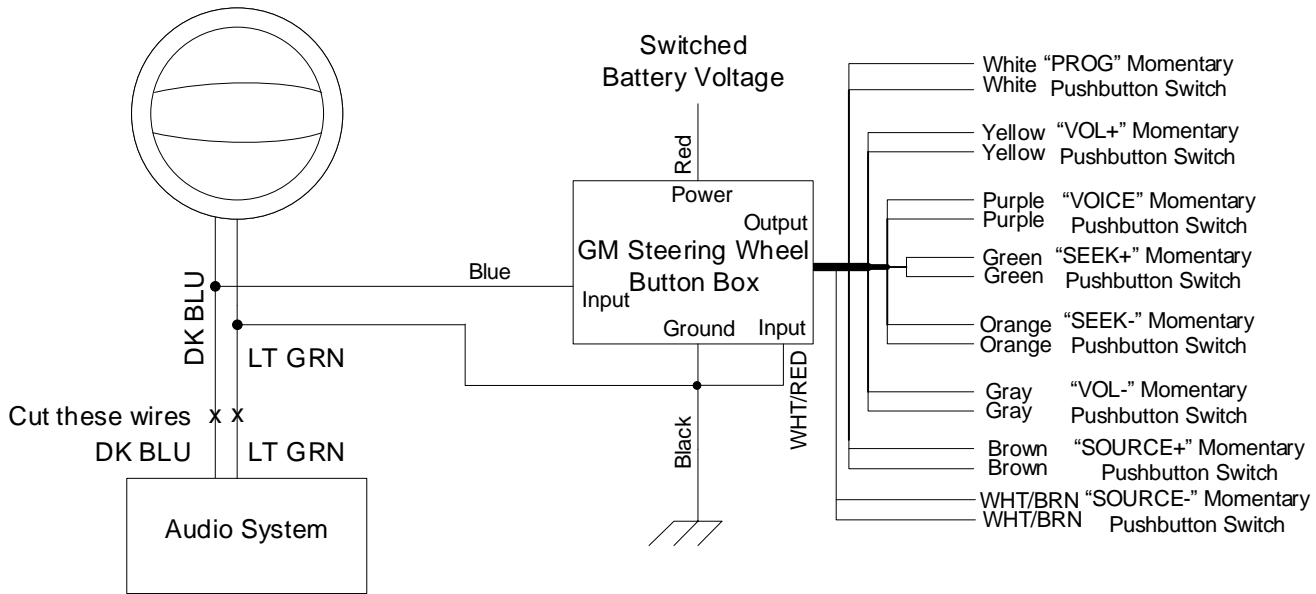

Each Steering Wheel Button Box output is rated to 125V and 1A. Switching of larger signals will require an additional external relay

Here is a schematic diagram of how to connect the Accutach GM Steering Wheel Button Box to an 03-06 Silverado with a 3PDT switch (Mode 4):

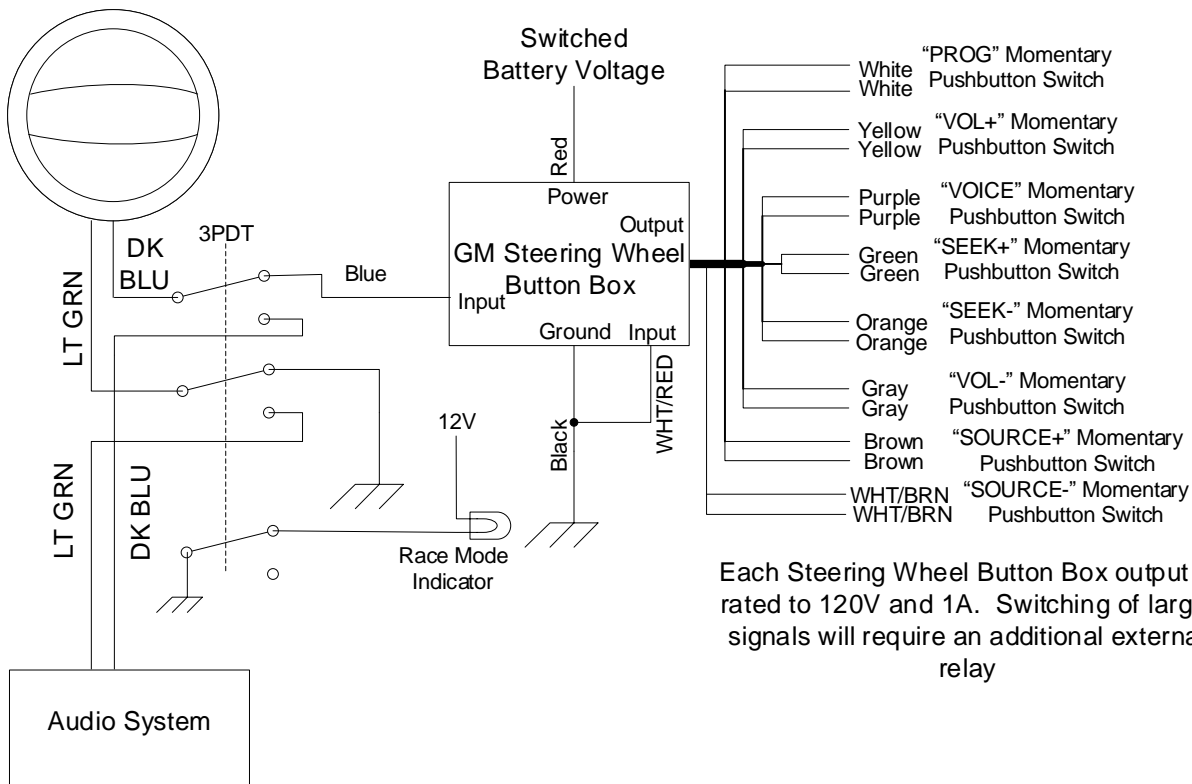

Each Steering Wheel Button Box output is rated to 120V and 1A. Switching of larger signals will require an additional external relay

04-09 Trailblazer, 05-08 Ascender, 04-07 Rainier (Mode 4)

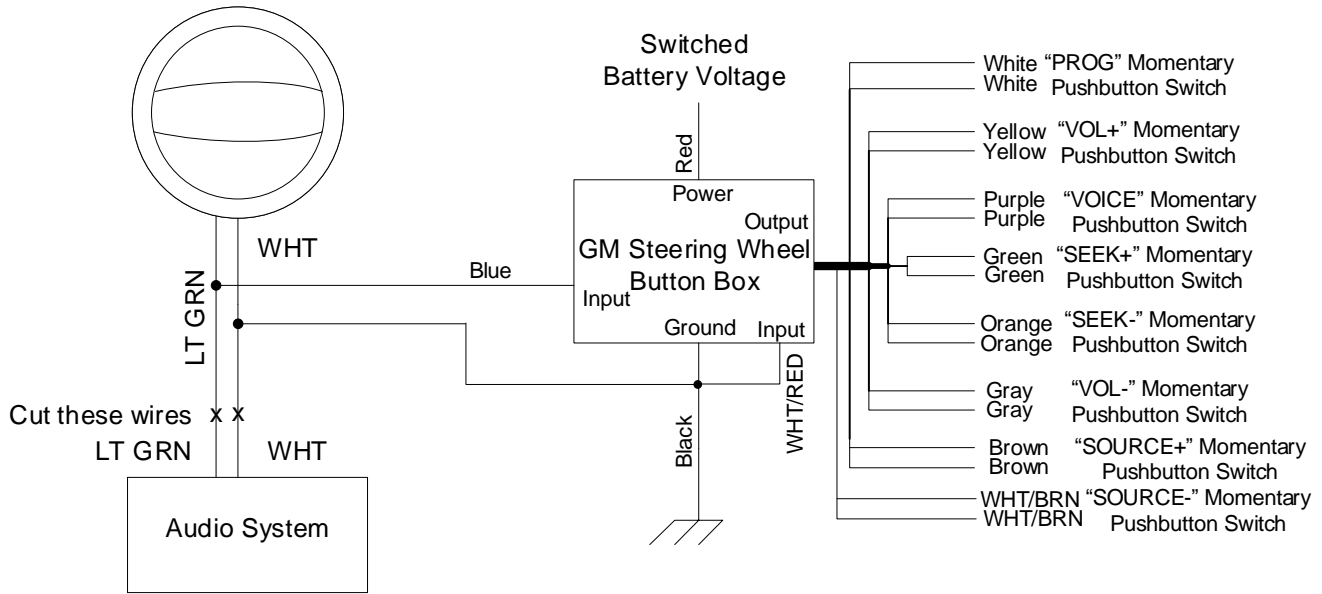

Each Steering Wheel Button Box output is rated to 125V and 1A. Switching of larger signals will require an additional external relay

Here is a schematic diagram of how to connect the Accutach GM Steering Wheel Button Box to an **04-09 Trailblazer, 05-08 Ascender or 04-07 Rainier** with a 3PDT switch (Mode 4):

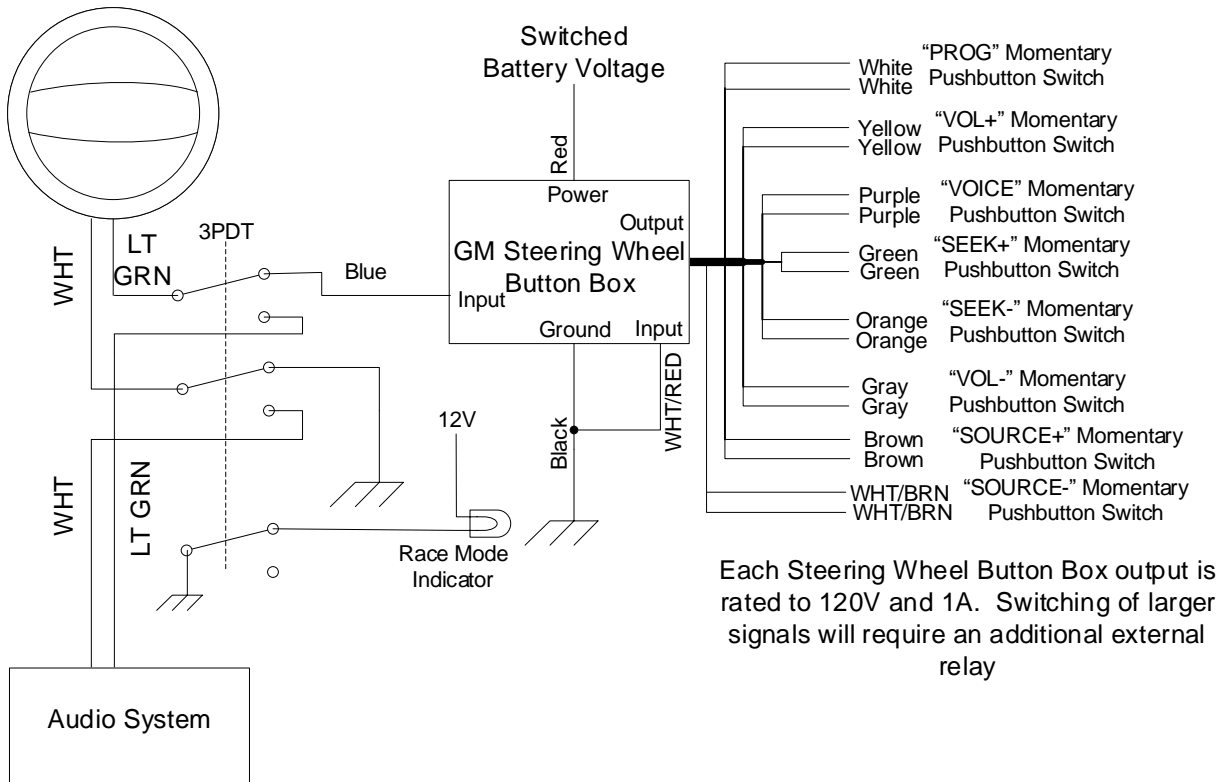

Each Steering Wheel Button Box output is rated to 120V and 1A. Switching of larger signals will require an additional external relay

10-15 Camaro, 11-16 Cruze, 14-16 Malibu, 11-15 Volt (Modes 0-3)

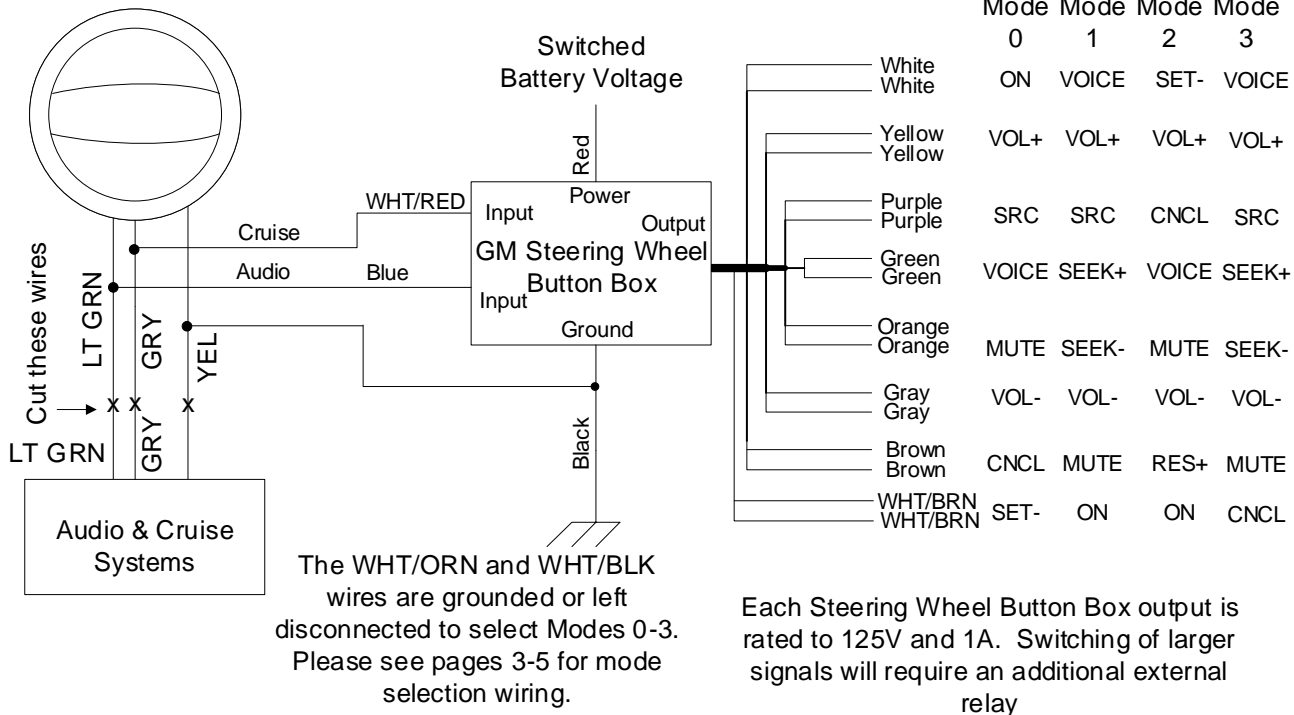

Here is a schematic diagram of how to connect the Accutach GM Steering Wheel Button Box to an 10-15 Camaro, 11-16 Cruze, 14-16 Malibu or 11-15 Volt with a 4PDT switch (Modes 0-3):

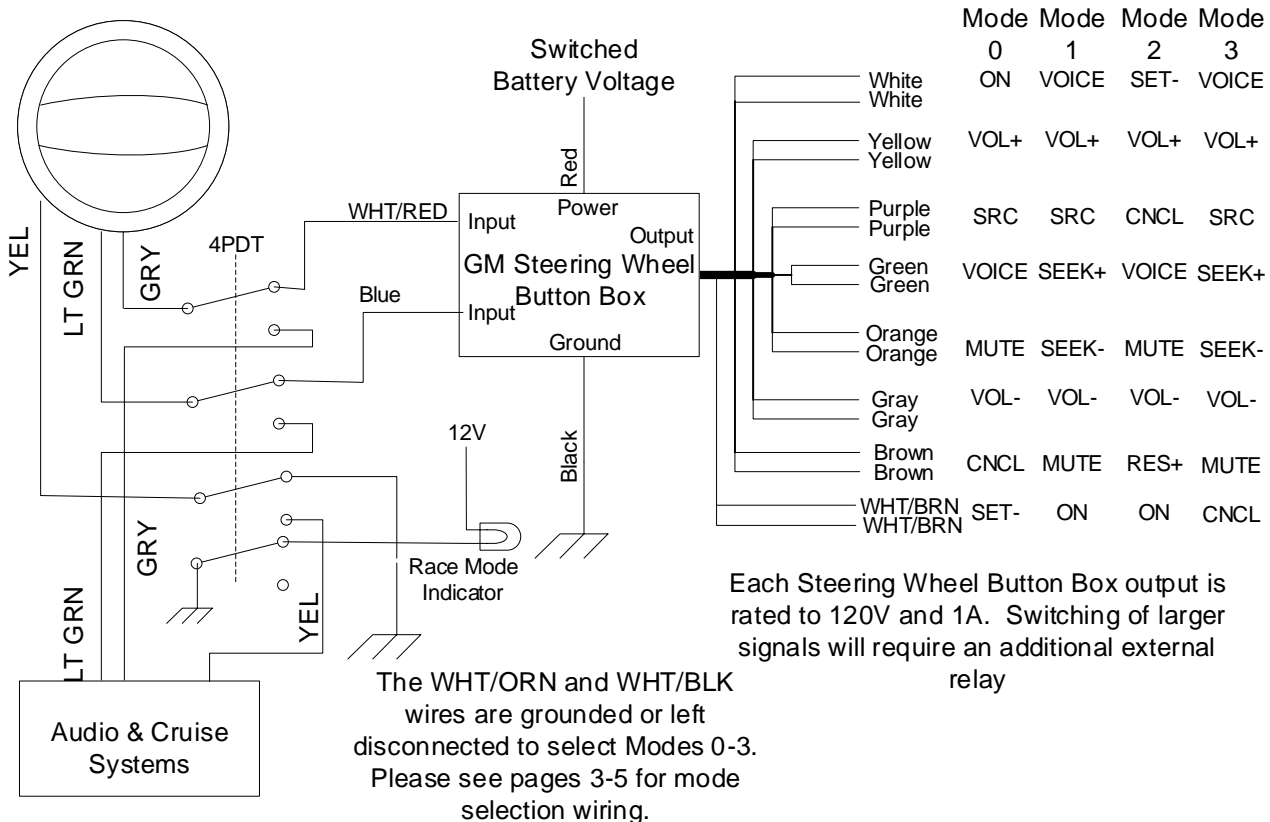

07-13 Silverado, 07-14 Tahoe, 07-13 Avalanche, 07-14 Suburban, 07-13 Sierra, 07-14 Yukon, 08-09 H2, 07-14 Escalade (Modes 0-3)

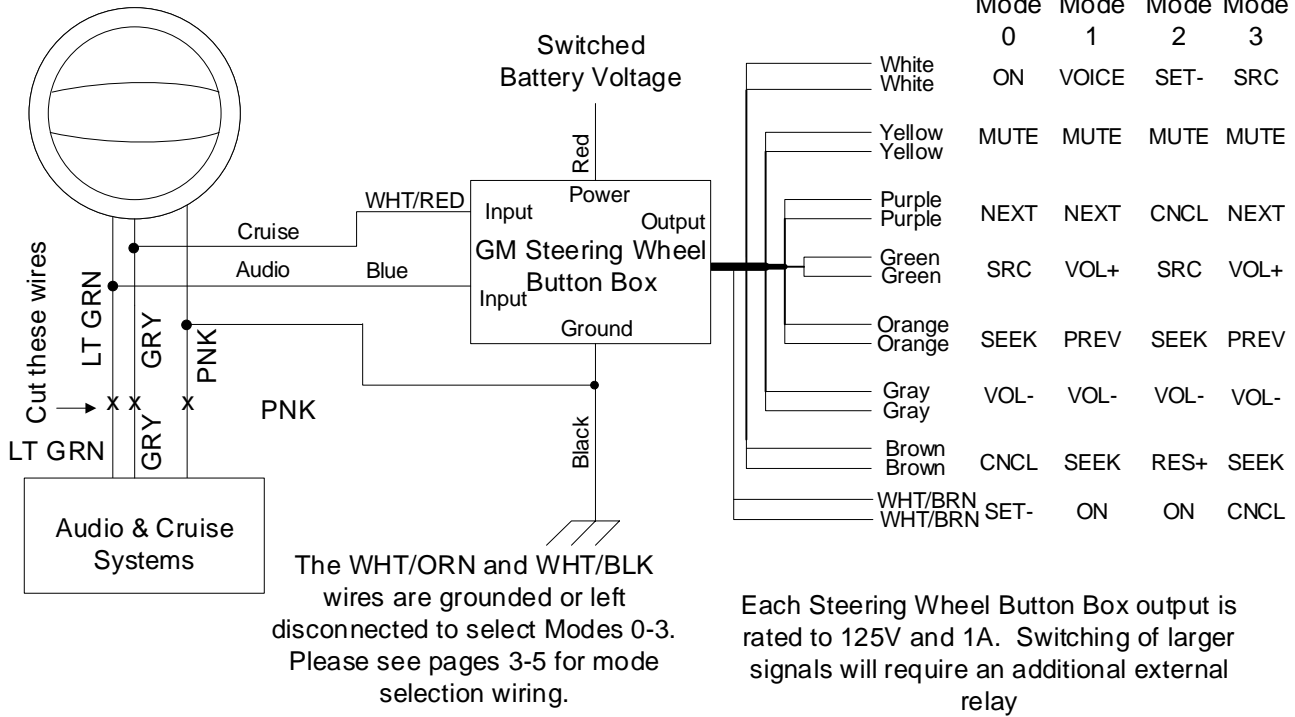

Here is a schematic diagram of how to connect the Accutach GM Steering Wheel Button Box to an 07-13 Silverado, 07-14 Tahoe, 07-13 Avalanche, 07-14 Suburban, 07-13 Sierra, 07-14 Yukon, 08-09 H2 or 07-14 Escalade with a 4PDT switch (Modes 0-3):

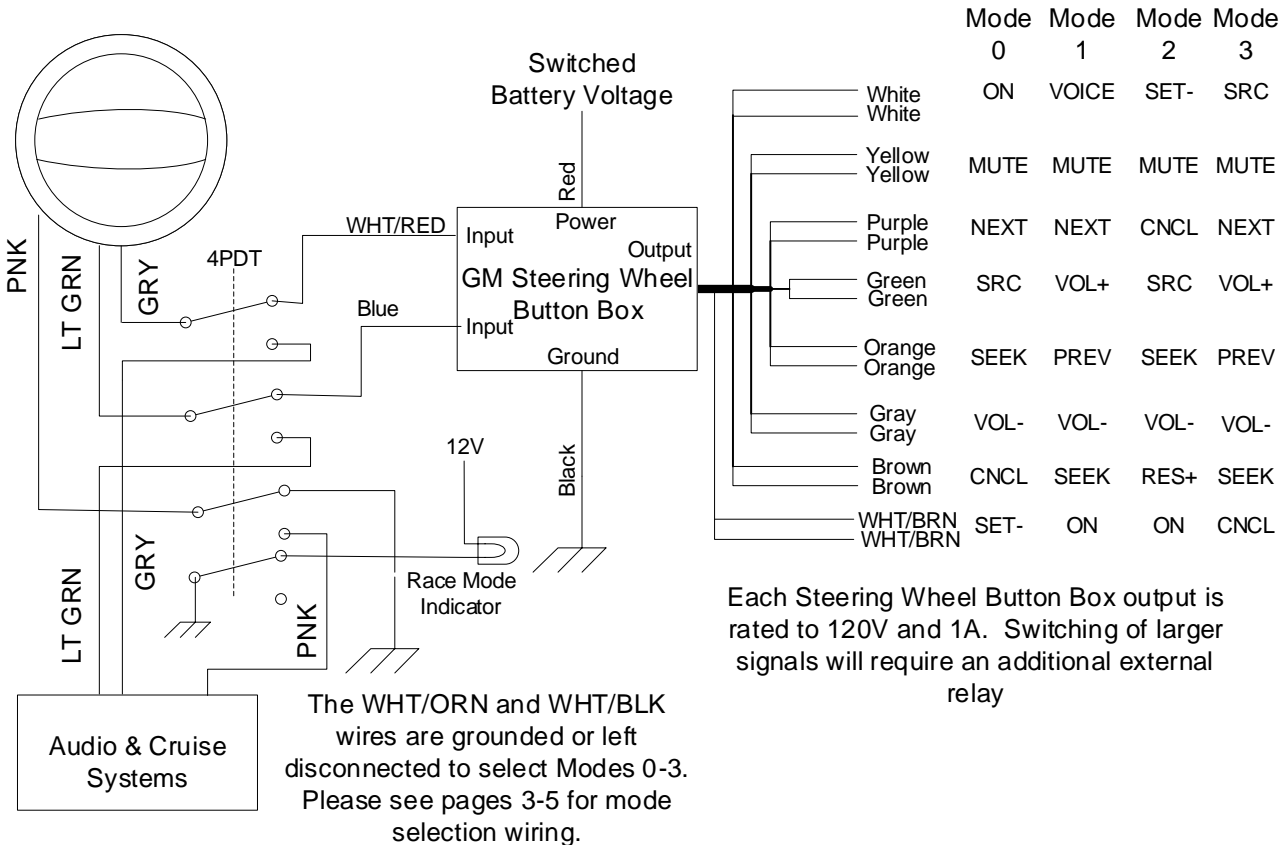

This would be a good time to test the installation of the Steering Wheel Button Box. After having connected the power ground and signal wires, turn the key on. With an ohmmeter across each pair of colored output wires, you should see an open circuit with no buttons pressed. With each button pressed, you should see a short circuit across the colored wire pair associated with that button. See the previous page for your GM vehicle to see the button to wire color mapping.

Pressing Multiple Buttons at Once

You can push multiple buttons from the same button group at the same time, but only one of the button functions will be activated. The button in the group with the lowest resistance of the pressed buttons is the only button that will work. See Page 8 for the resistances associated with each button. For example, if a Corvette VOL+ and VOL- are pressed at the same time, only the wire color associated with the VOL+ button (Yellow) will be activated.

For vehicles with both cruise and audio signals, one button from the cruise control buttons and one button from the audio buttons can be pressed at the same time. Note that the ON switch enables or disables all of the cruise control buttons in that mode.

Connecting to Accessories

Connect any of the colored wire pairs to whatever accessory you want controlled by the corresponding steering wheel momentary pushbutton switch or the cruise control ON switch. Each switch output is rated to 120V and 1A. Higher rated signals must be controlled by an external automotive relay.

The GM Steering Wheel Button Box typically draws less than 20mA quiescent and less than 140mA when one or two buttons are pressed.

Auxiliary Switch Units

All of the GM steering wheel buttons except the cruise control On switch function as momentary-on pushbutton switches. The cruise control On switch is a mechanical toggle switch. If you need a switch that functions as a toggle rather than ones that are only momentarily on (or more than one in a car with cruise control), Accutach Co. has developed two different auxiliary switch units which can be used in conjunction with any momentary switch (ideal for use with Accutach's Steering Wheel Button Box) to operate devices which normally use a toggle switch (typical on/off function). These two different devices cover just about any application. The Accutach Co. auxiliary switch units can switch circuits up to 120V, 1A. Switching higher voltage and/or current signals will require the use of an external relay. The Accutach Co "On/Off Auxiliary Switch Unit" and the "Toggle Auxiliary Switch Unit" are described below.

On/Off Auxiliary Switch Unit

Some people will prefer to turn an accessory on with one momentary pushbutton switch and off with another momentary pushbutton switch. The Accutach Co. On/Off Auxiliary Switch Unit provides two such circuits in one small box. For example, the Corvette Steering Wheel Vol+ and Vol- buttons could be used to turn one accessory on and off and the Up and Down buttons could be used to turn another accessory on and off. The Auxiliary ON/OFF Box Install Guide will give you more information: https://img1.wsimg.com/blobby/go/1975f84f-4935-4131-8404-5a914da1afb7/downloads/1c2pl1v81_301699.pdf.

Toggle Auxiliary Switch Unit

Some people will prefer to turn an accessory on with one momentary pushbutton switch and then off again with the same momentary pushbutton switch. The Accutach Co. Toggle Auxiliary Switch Unit provides one such unit in a small box. One of these boxes will be required for each pushbutton that is to be turned into a toggle switch.

For example, the Corvette steering wheel 1-6 Preset button could be used in conjunction with a Toggle Auxiliary Switch Unit to power a brake line-lock unit during a tire-heating burnout. The driver would press the 1-6 Preset button once to engage the line lock and once again to disengage it. The Auxiliary Toggle Box Install Guide will give you more information: https://img1.wsimg.com/blobby/go/1975f84f-4935-4131-8404-5a914da1afb7/downloads/1c2pkjs2u_541911.pdf

Troubleshooting:

With battery power (around 12V) and ground applied to the Steering Wheel Button box, and no button pressed the voltage on the input wire(s) should be somewhere in the neighborhood of 5 volts. If they are not near 5 volts, disconnect them from the OEM signal wire and check again. If they are not near 5 volts when disconnected, contact Accutach Co. to return the defective unit. If they are near 5 volts when disconnected from the car, check the OEM signal wire(s) to make sure the OEM radio/cruise units are not still connected to the circuit.

Double check your mode selection wiring to ensure you are using the correct mode for your vehicle.

To test the buttons on your steering wheel, disconnect the steering wheel signal wire(s) from the Steering Wheel Button Box input(s). With the key off and an ohm meter across the signal wire and ground, you should see infinite resistance with no button pressed.

When you press each button, you should see a resistance close to the resistance listed for that button on page 8.

To test your cruise button box, connect the power ground and connect the Steering Wheel Button Box input wire(s) to the OEM Signal wire(s) as specified previously in this document. Disconnect all of the colored wire pairs. Turn the key on. With an Ohm meter, test all of the colored wire pairs coming from the unit. With no button pressed, all of the wire pairs should show infinite resistance. With the press of each button, the one wire pair should show a near zero resistance. All of the other wires should show an open circuit.

Find your vehicle on pages 11-17 to find the mapping of buttons to wire colors for the tests.

If you do not get these results, make sure that the signal and power wire(s) in the steering column are cut, and the Steering Wheel Button Box input wire(s) have good connections to the Steering Wheel Button Box wire(s) that go up to the steering wheel, not down to the audio/cruise systems. If the signal wire(s) are not cut, the car's systems will load the wire so the cruise button box will not work. Also make sure the Power wire is cut and the side that goes up to the steering wheel is grounded to the same ground that the Accutach Co Steering Wheel Button Box uses.

If the input wire(s) are wired correctly, make sure that the voltage on the red wire is very close to battery voltage. If it is not very close to battery voltage, make sure the connection to power is a good connection. Also, make sure that you have a very good ground connection.

Feel free to contact Accutach company if you have any questions or issues with the Steering Wheel Button Box