

**Anatomy of the IMRC Motor Unit
96-98 Ford Mustang Cobra R1.2**

© 2017, 2021 Accutach Co.
Mark Olson

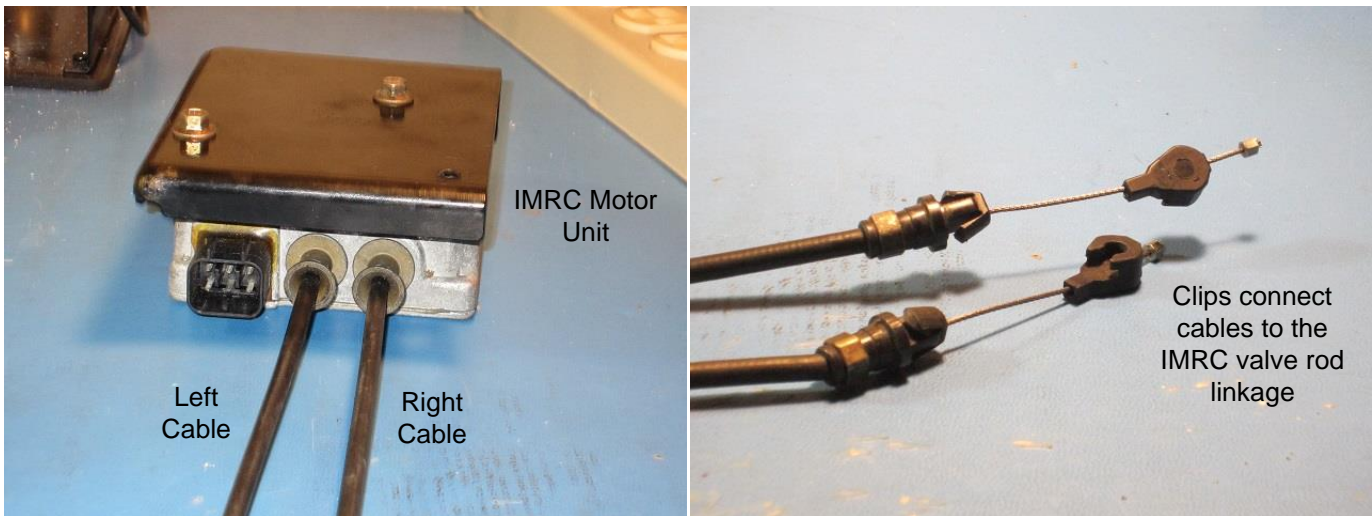

96-98 Ford Mustang Cobras (along with some Lincoln Mark 8s and Continentals) came with B-headed 4.6L 4-valve motors. Each cylinder has 4 ports, 2 intake and 2 exhaust ports. Of the two intake ports, one is the square primary port and the other is the round secondary port. The fuel injector is located in the primary port. There is nothing in the secondary port. There is a butterfly valve in each secondary port controlled by a rod running through all of the ports of each bank. There is a spring on each rod that keeps the butterfly valves closed. At the rear of each bank, there is a linkage that connects to a cable that runs to a central motor unit mounted to the bottom of the intake manifold. That motor unit pulls on the cables to open the valves when the PCM commands it. A resistor sensor in the motor unit allows the PCM to monitor the motor unit to ensure that it is working properly.



This system is called the Intake Manifold Runner Control or IMRC system. The PCM allows the IMRC valves to remain closed at low RPMs, which increases the velocity of the air/fuel mixture as it flows into the cylinder head. The increased velocity crams more air and fuel into the cylinder, resulting in more torque at low RPMs. As the RPMs go up, the port velocity goes up but larger port size becomes more important, so the PCM opens up the IMRC valves when the RPMs exceed a programmed value. As the RPMs drop down below that value, the motor stops pulling the cables and lets the springs close the IMRC valves.

Ford has discontinued the IMRC motor unit, so this rare part will only get rarer as time goes on. As a result, I have decided to reverse engineer the IMRC motor unit so people can repair these units and keep their B-headed motors on the road in stock condition should they so desire. (Accutach Co. sells an IMRC Delete Relay Unit for those who want to delete the IMRC valve but don't want a custom tune to avoid the computer issues associated with the delete.)

Note: Replacement cable sheaths are not available, so be careful not to break off the plastic tabs that hold the sheaths to the IMRC lever brackets. If the cable sheaths break, there are a couple of work-arounds discussed at the end of the document, but they are inconvenient. It is much better to not break the tabs off in the first place.

There are three common failure modes for the IMRC Motor Unit: electronic failure, cable fraying or broken cable clips. Repairs of all three failures will be explored by this document. This document assumes that you have already removed the intake manifold from the engine, unclipped the cables from the IMRC linkages and the IMRC Motor Unit has been removed from the bottom of the intake manifold.

There are two electronic subsystems in the IMRC Motor unit, the monitoring subsystem and the control subsystem:

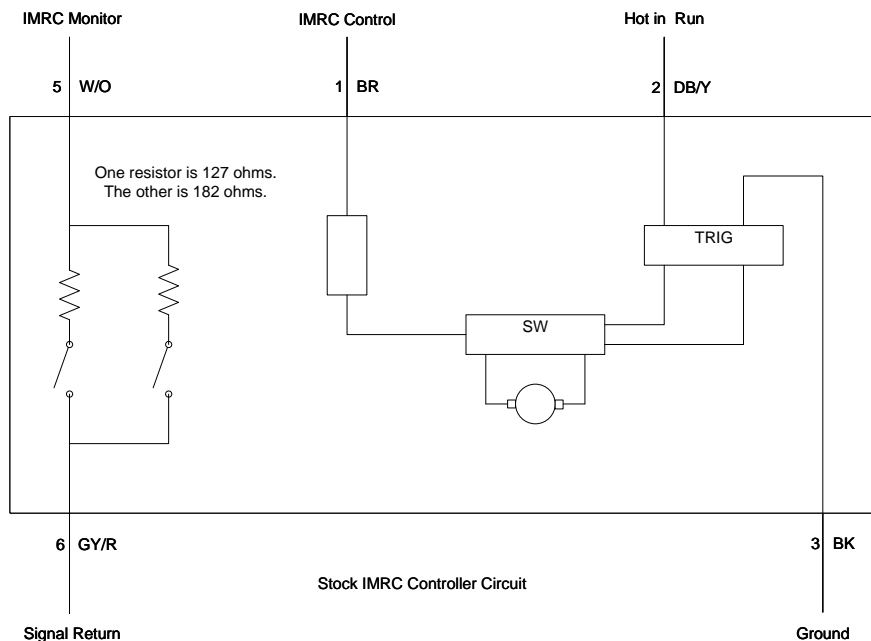

The monitoring subsystem consists of a pair of pins that the PCM monitors to ensure proper operation. Each cable has a cam that drives a switch that is in series with a resistor. The two switches/resistors are wired in parallel. When the IMRCs are closed, both switches are open, resulting in the PCM seeing infinite ohms of resistance. When the IMRCs are both open, both switches are closed, connecting both resistors in parallel, resulting in a resistance across the pins of approximately 75 Ohms. If the left switch only closes only the 127 Ohm resistor is connected across the pins, putting approximately 127 Ohms across the pins. If the right switch only closes only the 182 Ohm resistor is connected across the pins, putting approximately 182 Ohms across the pins. With both resistors connected in parallel, the resistance will be approximately 75 Ohms.

Cams

Switches

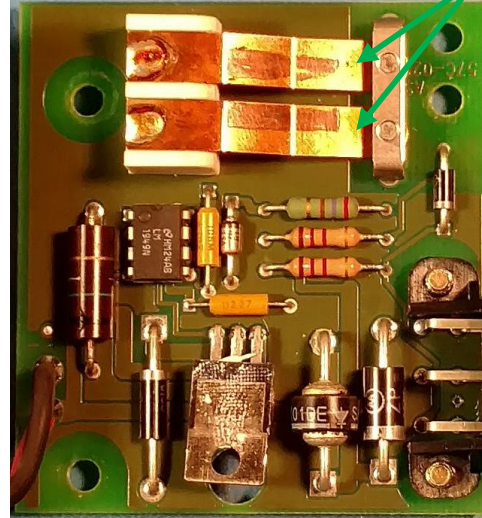
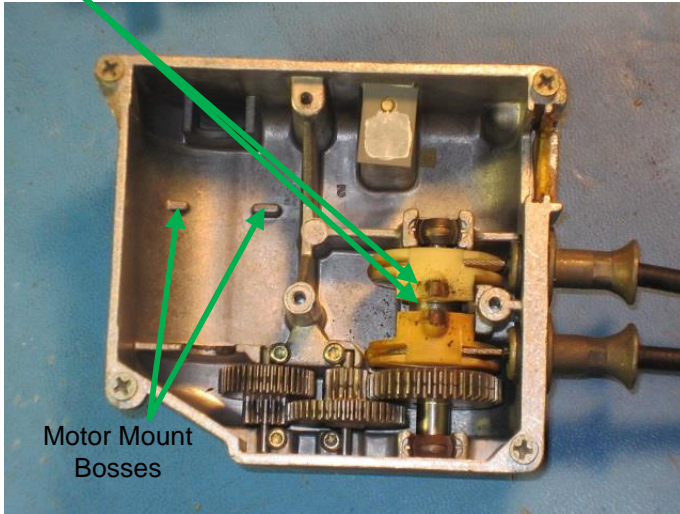

If the PCM sees an unexpected resistance, it will set an IMRC-related Diagnostic Trouble Code (DTC) and a Check Engine Light (CEL). See the Appendix at the end of this document for the Mustang Cobra IMRC related DTCs.

The other subsystem allows the PCM to open and close the valves. One pin supplies power to the motor control unit and another supplies power ground. A third pin causes the motor to pull the cables when it is grounded or to relax when not grounded to allow the IMRC springs to close the IMRC valves.

IMRC Motor Unit Connector Pinouts

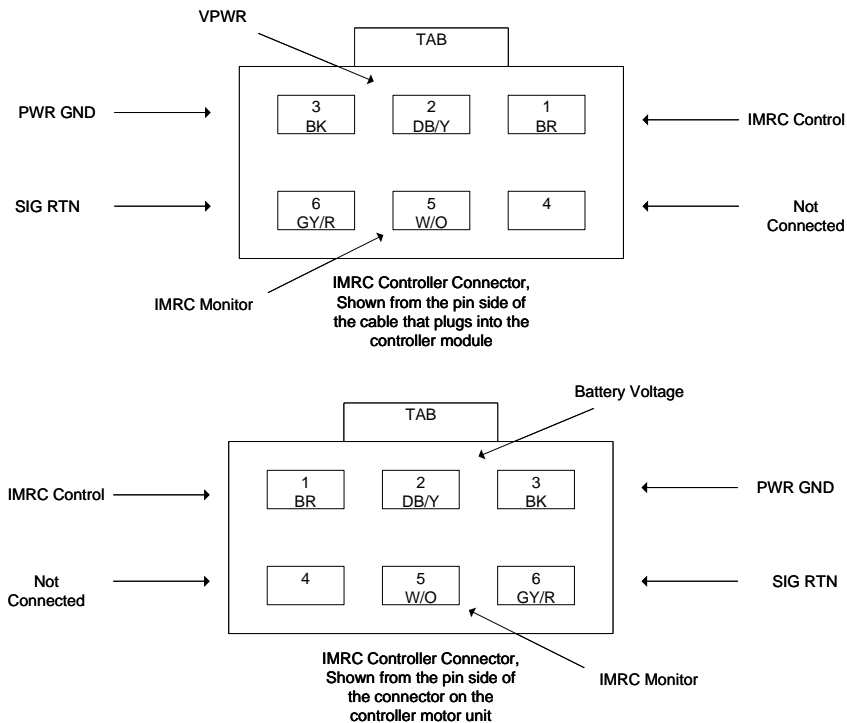

Testing the IMRC Motor Unit

This information is provided to you for the purpose of understanding how the Ford Mustang Cobra IMRC Motor Unit works. Mark Olson and Accutach Company are not responsible for any damage of any kind if you try to test, modify or repair IMRC Motor Units on your own.

You will need a well regulated 12V power supply capable of supplying at least 3 Amps of current. A charged car or motorcycle battery will work well. You will also need 3 small alligator clipleads and an ohmmeter in order to test the unit.

To test the sensor subsystem, ensure that both cables are fully pulled out of the motor unit. Connect one cliplead (yellow in this case) to pin 5 and another cliplead (green in this case) to pin 6.

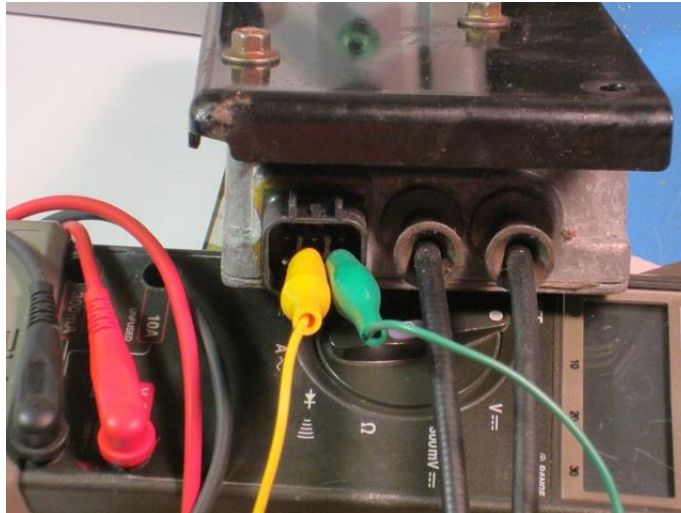

Put the ohmmeter across the other ends of the clipleads. You should read infinite Ohms when both cables are pulled fully out.

Push the left cable in until you feel the cam release the switch. You should see the resistance on the ohmmeter change to be about 127 Ohms. Pull the left cable fully out again. Push the right cable in until you feel the cam release the switch. You should see the resistance on the ohmmeter change to be about 182 Ohms. Push the left cable in again so both cables are in. You should see the resistance on the ohmmeter change to be about 75 ohms. Flex the connector up and down by hand with the cables pushed fully in to see if the resistance changes as you flex it. If the resistance changes, there are cold solder joints on the connector pins that need repair. If you don't get 75 ohm readings, there is an issue with the sensor subsystem that need to be investigated. Possible failures will be discussed later in this document.

To test the control subsystem, ensure that both cables are pulled fully out of the motor. Connect one cliplead (yellow in this case) to pin 1 (Control signal), another cliplead (red in this case) to pin 2 (power) and a third cliplead (green in this case) to pin 3 (Ground).



Connect the pin 2 cliplead to your power supply and connect the pin 3 cliplead to power ground. The cables should not move. When you ground the pin 1 cliplead, the motor should pull both cables fully into their sheaths. When you un-ground pin 1, you will be able to pull the cables out again. If the motor unit that you are testing passes these tests, the IMRC Motor Unit is fully functional.

If you try to keep the cable from pulling in by hand, the motor will overcome you trying to hold it. I have had one unit in for repair that had very weak pulling force that could be stopped with your fingers. It is a good idea to test the pulling strength when testing a controller.

Disassembly

It is much easier to work on the IMRC Motor Unit if your first remove the two bracket bolts with an 8mm wrench and then remove the mounting bracket.

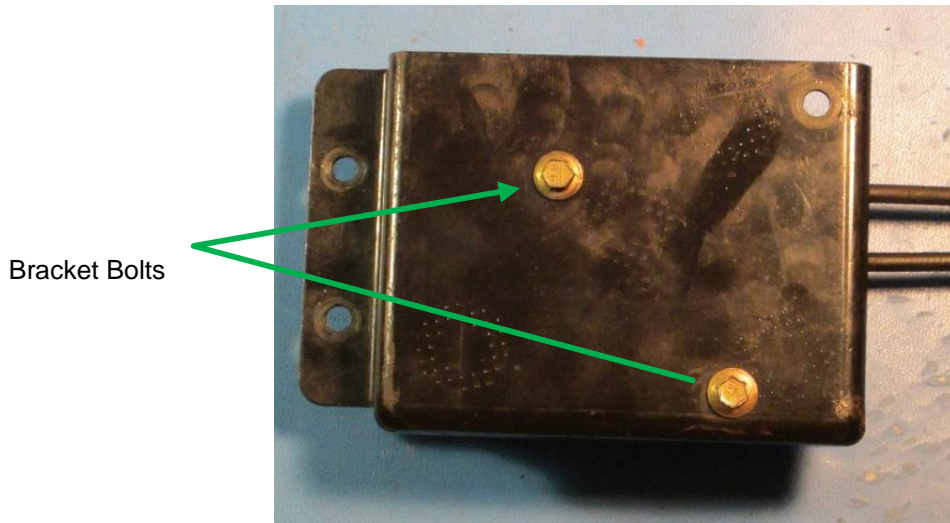

This exposes the top of the IMRC controller case. It has a Ford oval logo and it says, "MFG BY STURDY CORP Wilmington NC MADE IN USA ACTUATOR 91492".

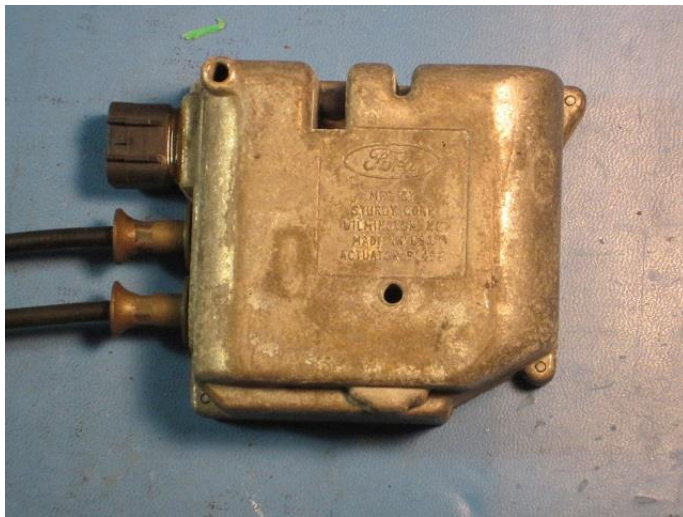

Flip the case over to get to the 4 case cover self-tapping screws:

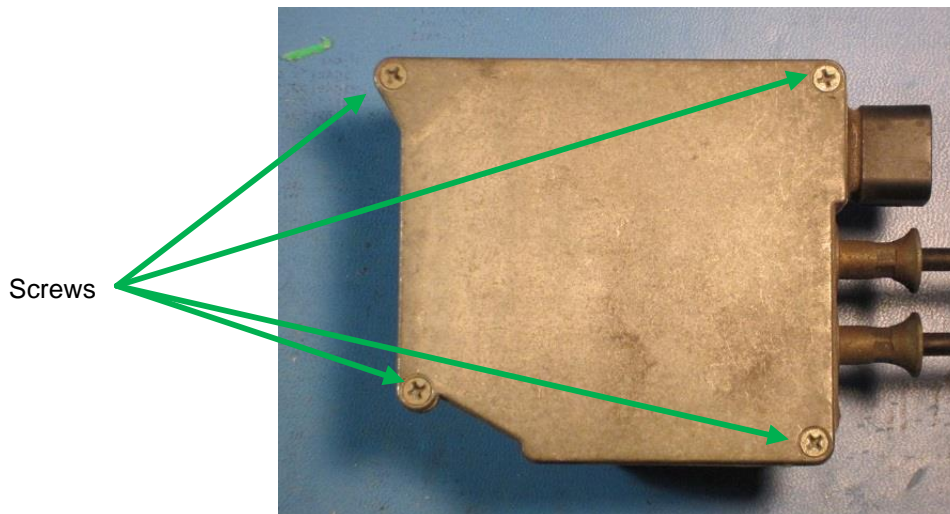

This is a photo of the inside of the case cover. It shows that Sturdy Corp used a Make-A-Gasket style seal for the cover.

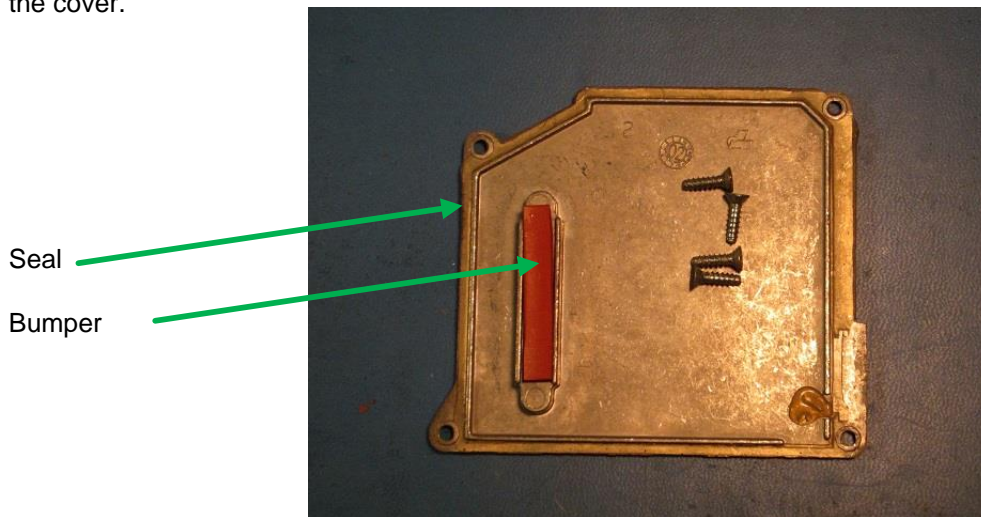

It also has a rubber bumper that holds the electric motor in place. If you want to operate the motor with the cover off, make sure you use one hand to firmly press the motor into the case so it will not jump teeth on the transmission gears.

This is how the inside of the case looks with the cover off:

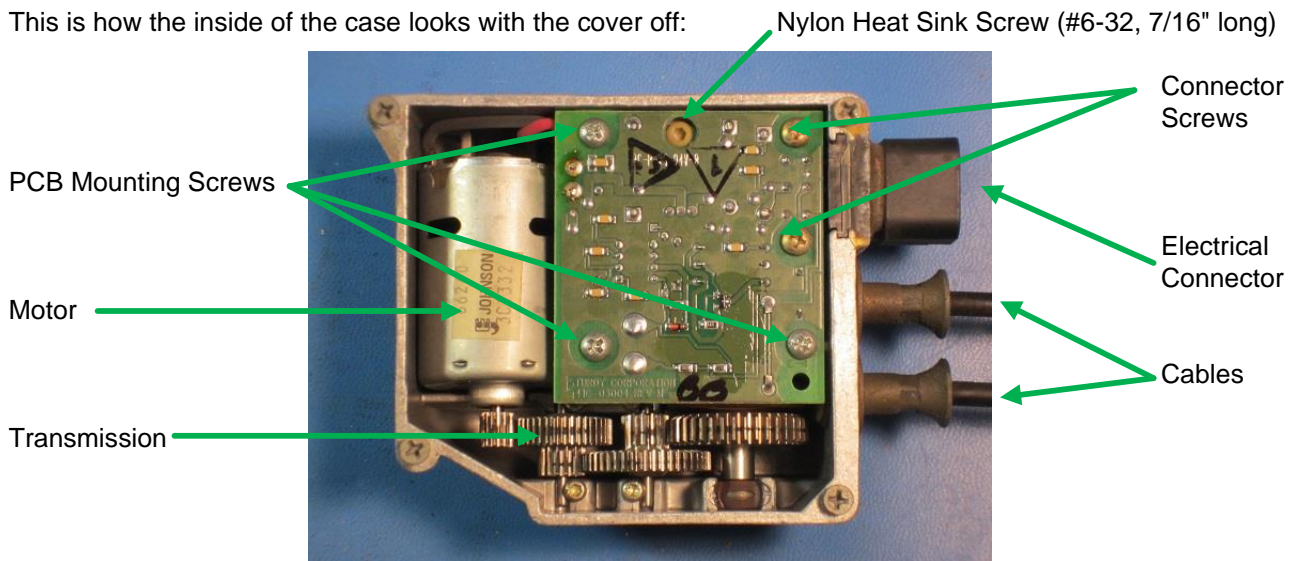

Note that early controllers used a metal screw with an insulating washer to hold the transistor to the heat sink. The metal screw has a different thread pitch than the nylon screw has. If your controller has a metal screw, don't lose the screw or the insulating washer as it can't be replaced with the #6-32 nylon screw. The insulating washer must be used to prevent a short circuit to the case.

You can test the function of the controller without opening it up. If the motor pulls strongly, the sensor resistance is close to 75 ohms with the cables pulled in and the resistance doesn't change when you flex the connector up and down, then your controller is good. If the motor pulls strongly and the sensor resistance changes with flexing the connector, you can remove the cover and resolder the connector pins without removing the PCB. Assuming there is a problem that can't be fixed with the PCB in place, it is now time to remove the Printed Circuit Board (PBC) mounting screws and the nylon Allen (7/64" wrench) or metal heat sink screw in preparation for the removal of the PCB.

The electrical connector appears to have been glued to the case with some sort of epoxy.

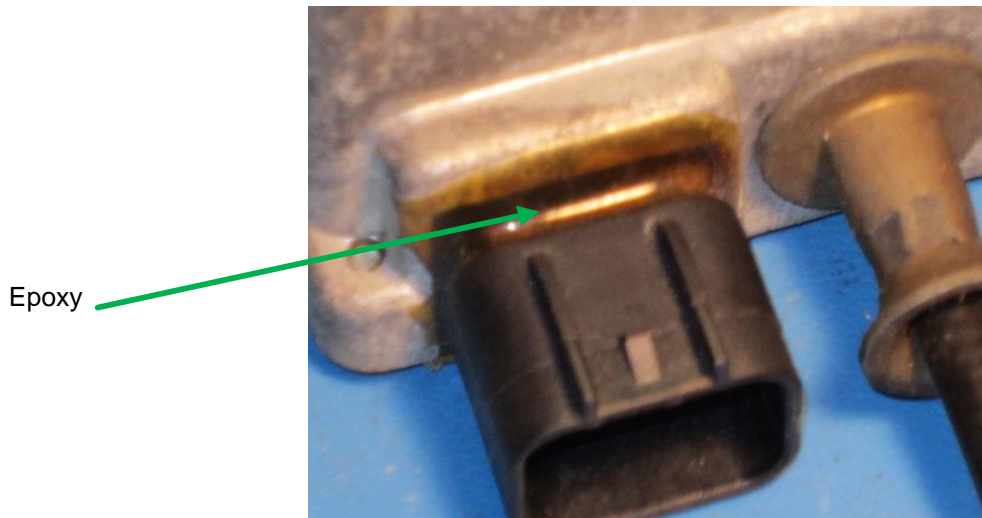

That epoxy needs to be dug out from between the connector body and the case. It is a very tough job that takes some tenacity to accomplish. The job is a bit easier if you heat up the epoxy with a heat gun prior to digging it out. Be careful with the heat gun so you don't melt the plastic connector body however.

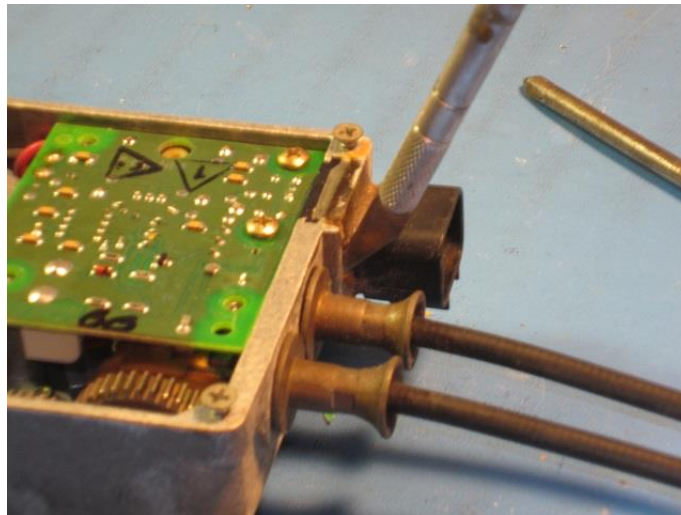

Here is the epoxy cleaned out from around the connector:



Carefully pry the connector up so it can be slid out of the case along with the PCB and motor. Don't break the connector. It can't be replaced except from another donor unit.

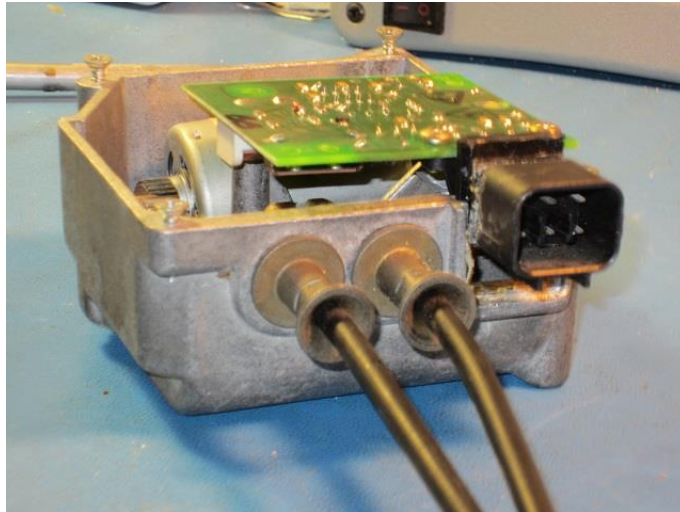

Here is the case with the PCB and motor removed:

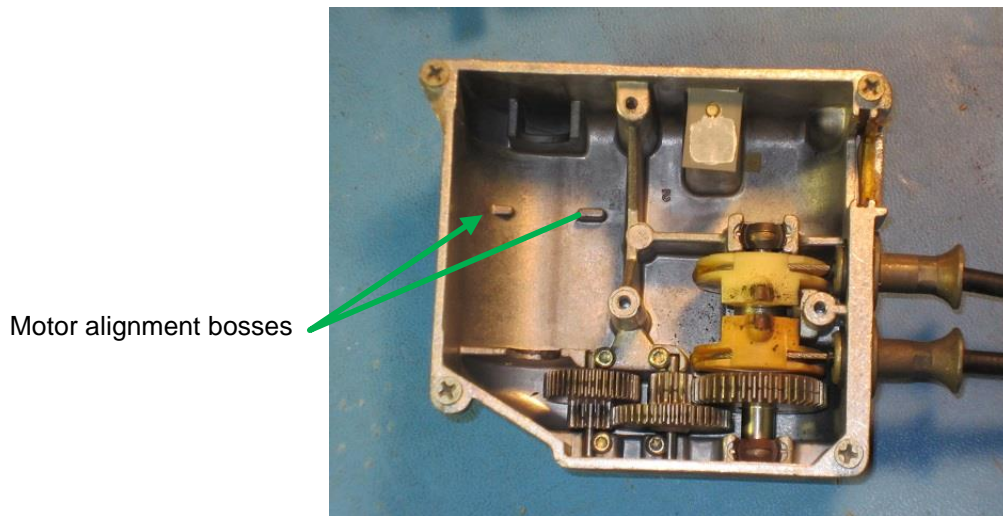

Here is the bottom of the PCB:

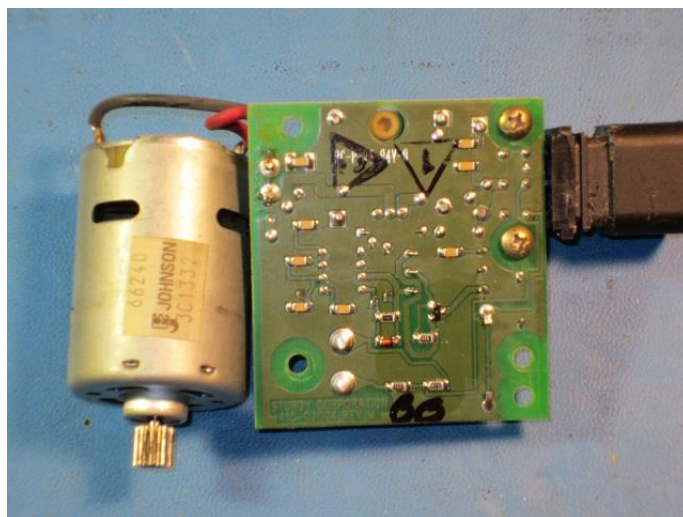

Here is the top of the PCB:

Motor Alignment Holes

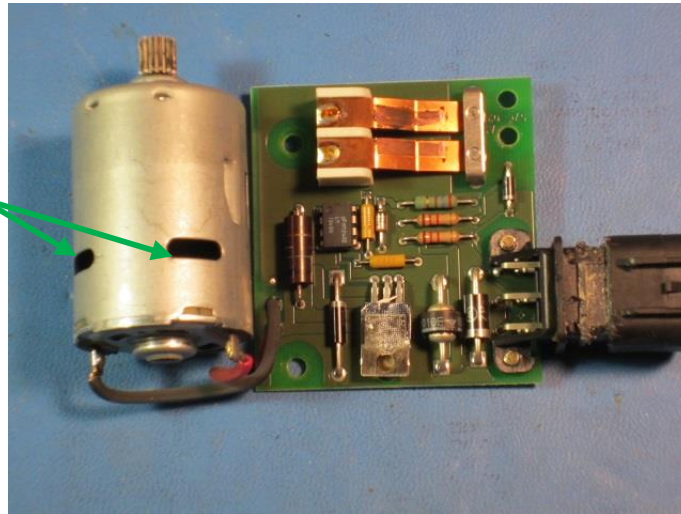

Reverse Engineering the Circuit

In order to keep track of the components on the PCB, we will need to label each of them, since the component names are not printed on the PCB. Here are the components on the top of the PCB:

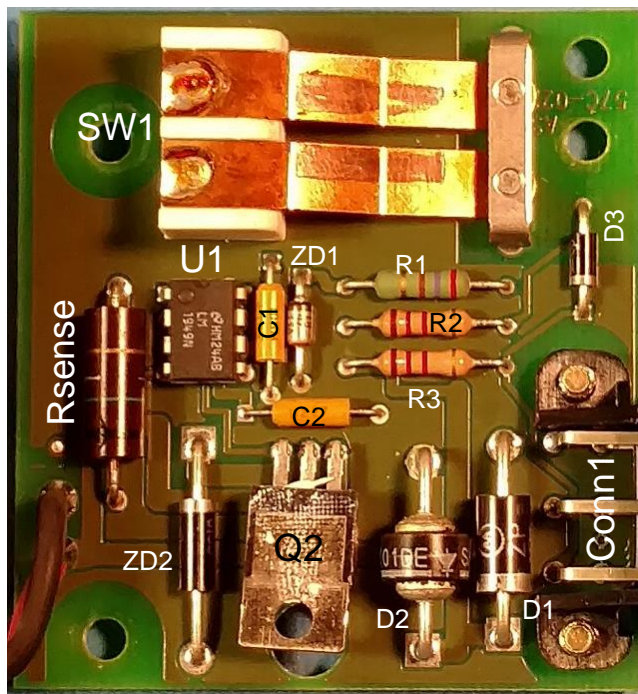

PCB Top

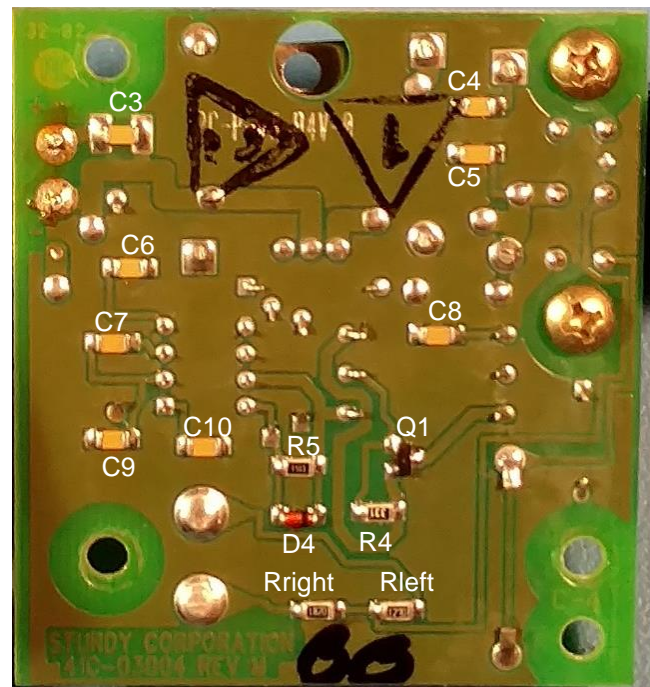

PCB Bottom

Electronics Bill of Materials:

U1 – LM1949 Injector Driver IC

Q1 – Bipolar PNP SMD Switching Transistor. An MMBTA92 will probably work.

Q2 – 2N6045 8.0 A, 100 V NPN Bipolar Darlington Power Transistor

Rs – 0.05 Ohm, 5% 2W Current Sensing Resistor

Rleft – 127 Ohm SMD Sensor Resistor

Rright – 182 Ohm SMD Sensor Resistor

R1 – 270 Ohms, 5% 1/4W Zener Diode Regulator Resistor

R2 – 1.2K Ohms, 5% 1/4W Base Current Limiting Resistor

R3 – 1.2K Ohms, 5% 1/4W Pull-up Resistor

R4 – 330 Ohm 1206 SMD Pull-up Resistor

R5 – 150K Ohm 1206 SMD Timing Resistor

C1 – 10uF Timing Cap

C2 – 10uF Filter Cap

C3 – 0.1uF SMD 1206 Filter Cap

C4 – 0.01uF SMD 1206 Filter Cap

C5 – 0.01uF SMD 1206 Filter Cap

C6 – 0.01uF SMD 1206 Filter Cap

C7 – 0.01uF SMD 1206 Compensation Cap

C8 – 0.01uF SMD 1206 Filter Cap

C9 – 0.01uF SMD 1206 Filter Cap

C10 – 0.1uF SMD 1206 Decoupling Cap

D1 – 1N5404 General purpose Diode for Reverse Polarity Protection

D2 – SK0228, Unknown Protection Diode, A Littlefuse SAC18 TVS will probably work.

D3 – 1N4004 Input Protection Diode

D4 – Unmarked SMD SOD80C Protection Diode. A Nexperia PMLL4148L,115 will probably work.

ZD1 – 1N4733A 5.1V Zener Diode, IC Power Supply.

ZD2 – 1N5364B 33V 5W Back EMF protection Diode

SW1 – DPST Sensor Switch

M1 – Johnson 66240 Motor

Conn1 – Connector

Schematics

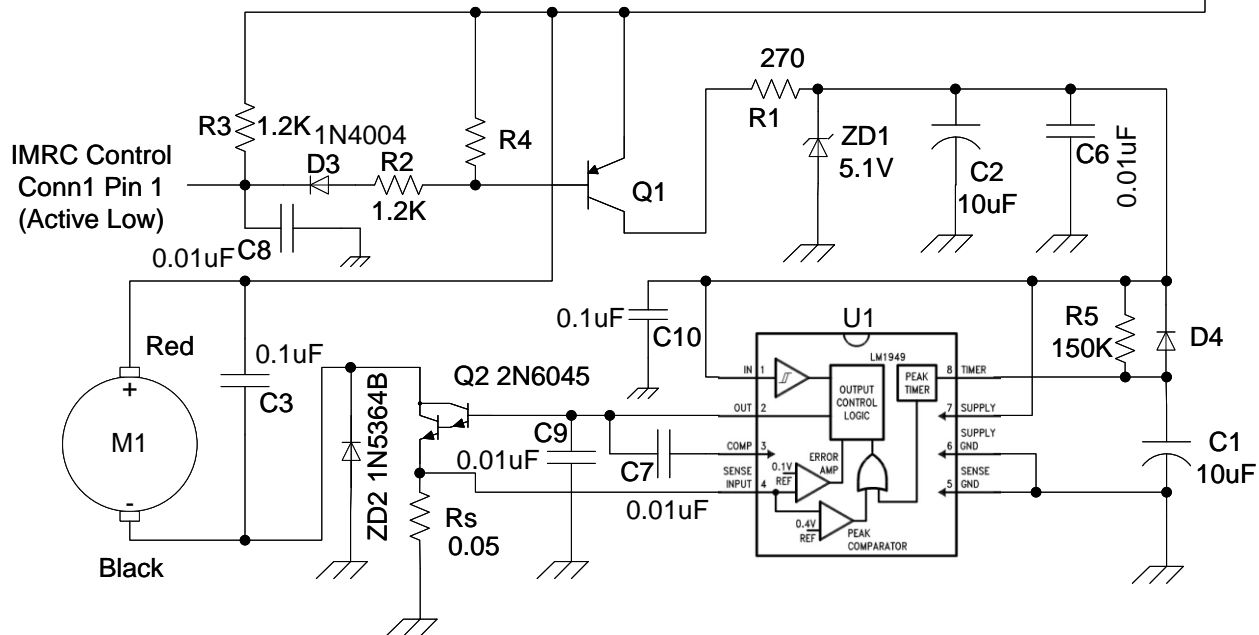
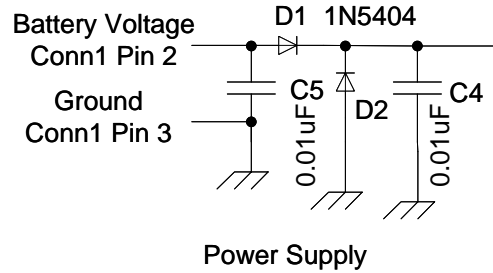
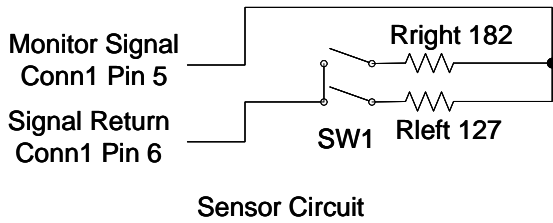

Operation of the Circuit

There are two independent circuits on the PCB, the sensor circuit and the motor control circuit. The sensor circuit provides resistance feedback to the PCM as to the state of the cables. The motor control circuit pulls or releases the cables based on the input coming from the PCM. This section describes in broad terms how the electronics of the IMRC Motor Unit operates. Detailed operation will be described in the diagnostic section.

Sensor Circuit

The Sensor Circuit provides one of four values of resistance back to the PCM which tells the PCM the state of both cables. It consists of a double pole, single throw (DPST) switch and two resistors. Connector Pin 6 (Signal Return) is connected to both poles on one side of the DPST switch. The other side of each pole of the DPST switch is connected to a resistor. The left pole is connected to a 127 Ohm resistor and the right pole is connected to a 182 ohm resistor. A cam on the cable linkage for each cable opens or closes each pole of the DPST switch.

With the PCB out of the case, it is probably a good idea to use a point file or emory board to freshen up to switch contact surfaces to ensure good electrical conduction when they are closed.

When both cables are fully extended (IMRCs closed), both switches are opened and there is infinite resistance across the signal and return pins. When both cables are retracted (IMRCs open), both switches are closed. That puts both resistors in parallel across the signal and return pins. Both resistors in parallel gives a resistance of 75 Ohms. If one cable is extended and the other is retracted (due to a problem with either bank of IMRCs) then either 127 Ohms or 182 Ohms will be across the signal and return pins. The resistance will be 127 Ohms if the right IMRC bank is closed and the left bank is open. The resistance will be 182 Ohms if the left IMRC bank is closed and the right bank is open. FYI, the signal return is not electrically connected to the Motor Control Circuit ground on the PCB.

If the resistance across the sensor and return pins is not what the PCM expects given the state of the IMRC control pin, the PCM will set a Diagnostic Trouble Code (DTC) and set the Check Engine Light (CEL). See the appendix for the Ford IMRC-related DTC definitions.

Motor Control Circuit

The Motor Control Circuit is much more complex compared to the Sensor Circuit. It uses three pins on the connector, battery power, ground and IMRC control. When the IMRC control pin is grounded, the IMRC motor is turned on to pull the cables and open the IMRC valves. When the IMRC control pin is ungrounded, the IMRC motor is turned off, allowing the IMRC springs to close the IMRC valves.

The motor control circuit uses a fuel injector controller integrated circuit to drive a bipolar Darlington power transistor to control the motor. The benefit of using the fuel injector controller is that it automatically delivers the inrush current the motor needs to get the IMRC valves open fast, and then it automatically drops back to a lower level holding current so the motor can hold the IMRCs open as long as they need to without generating a lot of heat or burning out the motor.

The input to the motor control is an active low input. At low RPMs, the PCM turns off an open collector output transistor which allows the input pin of the Motor Control Circuit to float up to battery voltage. At high RPMs, the PCM turns on the open collector output transistor which essentially grounds the input pin of the motor control input. The input pin is connected to the base of a bipolar PNP transistor that turns on when it is pulled down and off when the base goes up to near battery voltage.

The output of the transistor supplies near battery voltage to supply power to a 5.1V Zener Diode power supply. When the 5.1V power supply is turned on, it powers up and activates the fuel injector driver IC. It then controls the power transistor which controls the ground side of the motor.

Diagnosis of problems

Again, you use this information at your own risk. Mark Olson and Accutach Co. are not responsible for any damage that you cause based on the use of this information.

General Diagnostic procedures

Check all pins, wires and components for corrosion. Clean up any corrosion you may find with contact cleaner spray, pencil eraser, fine sandpaper, fiberglass bristle brushes, etc. There are many YouTube videos that show how to clean up corroded electronics.

The bottom of the PCB is coated with a fairly thick clear layer of some kind of conformal coating to help prevent corrosion. If you need to electrically probe any location on the bottom of the PCB, you must press a sharp probe in with enough force for the probe point to penetrate the conformal coating. Failure to penetrate the coating will prevent the instrument you are using from seeing the voltage or resistance.

Sensor Circuit Diagnostics

The sensor circuit can be diagnosed very easily. To check out the DPST switch, pull the cables in to ensure that the switches close.. If the sensor resistances are higher than they should be, check the switch contacts for corrosion or wear and freshen them up if needed using a point file, a women's nail emery board or a bit of fine sandpaper. With the cams holding the switches open, check the resistance of both Rleft and Rright for about 127 Ohms and 182 Ohms respectively. In the very rare case that the resistors need to be replaced, standard 1206 footprint SMD resistors may be used. I know of no source for the switch or the connector, so they will need to be repaired, if possible, if they are damaged or corroded. Contact corrosion problems are fairly common, filing or sanding can fix that. Cold solder joints are very common. They add resistance to the circuit and the resistance changes as you flex the connector up and down. The connector pins need to be re-soldered in that case.

Motor Control Circuit Diagnostics

This section will detail how the circuit works and give hints as to what may fail. Until we have a lot more experience diagnosing failed units, it will be difficult to give better debug procedures. Be sure to have a good voltmeter or even better an oscilloscope for doing the diagnostics.

Using clip leads, power the IMRC Motor control unit with a charged car/motorcycle battery or >3A well regulated bench power supply. Put the ground clip lead to Pin 3 and the power clip lead to Pin 2. Don't ground the IMRC control input, Pin 1. If the motor does not work, frequently it is due to a failed D1 diode.

All of the voltage measurements below are approximate.

The battery voltage part of the circuit has power whenever the key is on in the car. There is a filter capacitor (C5) at the input to smooth out noise on the power line. The power goes through diode D1 which provides protection against anyone accidentally reversing the polarity of the battery or jumper cables. I have seen a number of D1 failures, so if the motor is not working, check D1. The power is further protected by diode D2 from positive voltage spikes such as those generated when the battery becomes disconnected while the alternator is spinning. With the IMRC motor turned off, there is a voltage drop of about 0.4V across D1 because very little current is flowing through it with the IMRC motor turned off. Capacitor C4 further filters the power after that. If the battery voltage is 12V, then the protected battery voltage will be about 11.6V. That voltage runs to the emitter of Q1, the red lead of the motor (and through to the emitter of Q2), C3, pull-up resistors R4 and R3.

Since R4 pulls the base of Q1 up to the same 11.6V that is on the emitter of Q1, transistor Q1 is turned off, so its resistance is extremely high. This drives the power voltage to about 0V for everything after Q1 to the Base of Q2. Q1 is the switch that controls power to the rest of the motor control unit, so the motor remains off while Q1 is off.

Since the base of Q2 is very close to 0V, then Q2 is off, which allows the emitter and the black side of the motor to go up to 11.6V. Since both sides of the motor are at the same voltage and there is no current flowing through it, the motor can not run.

At this point, you can ground the clip lead connected to the IMRC Control Input Pin 1. That should cause the motor to start spinning on the bench.

When Pin 1 is grounded (0V), the input to resistor R2 is pulled down by diode D3. Current starts to flow through Q1's emitter to base, so the base voltage goes to about 10.6V. When current flows through the Emitter to base, then Q1 turns on, letting a lot of current flow across the emitter to the collector of Q1. That turns the power on to the rest of the Motor Control Unit. When that circuitry is turned on, a lot more current flows through the protection diode D1. That causes the voltage across the diode to drop more than it did at low current, so the voltage after D1 drops to 11.3V.

Since Q1 is turned on, current will start to flow through regulating resistor R1. The amount of current is determined by the voltage drop across 11.3V to the 5.1V of the Zener Diode, ZD1. Together R1 and ZD1 make a 5V voltage regulator circuit to power the rest of the motor control circuit. C2 and C6 filter that 5V power, removing noise.

Voltages While Pin 1 is Grounded and the Motor is Running

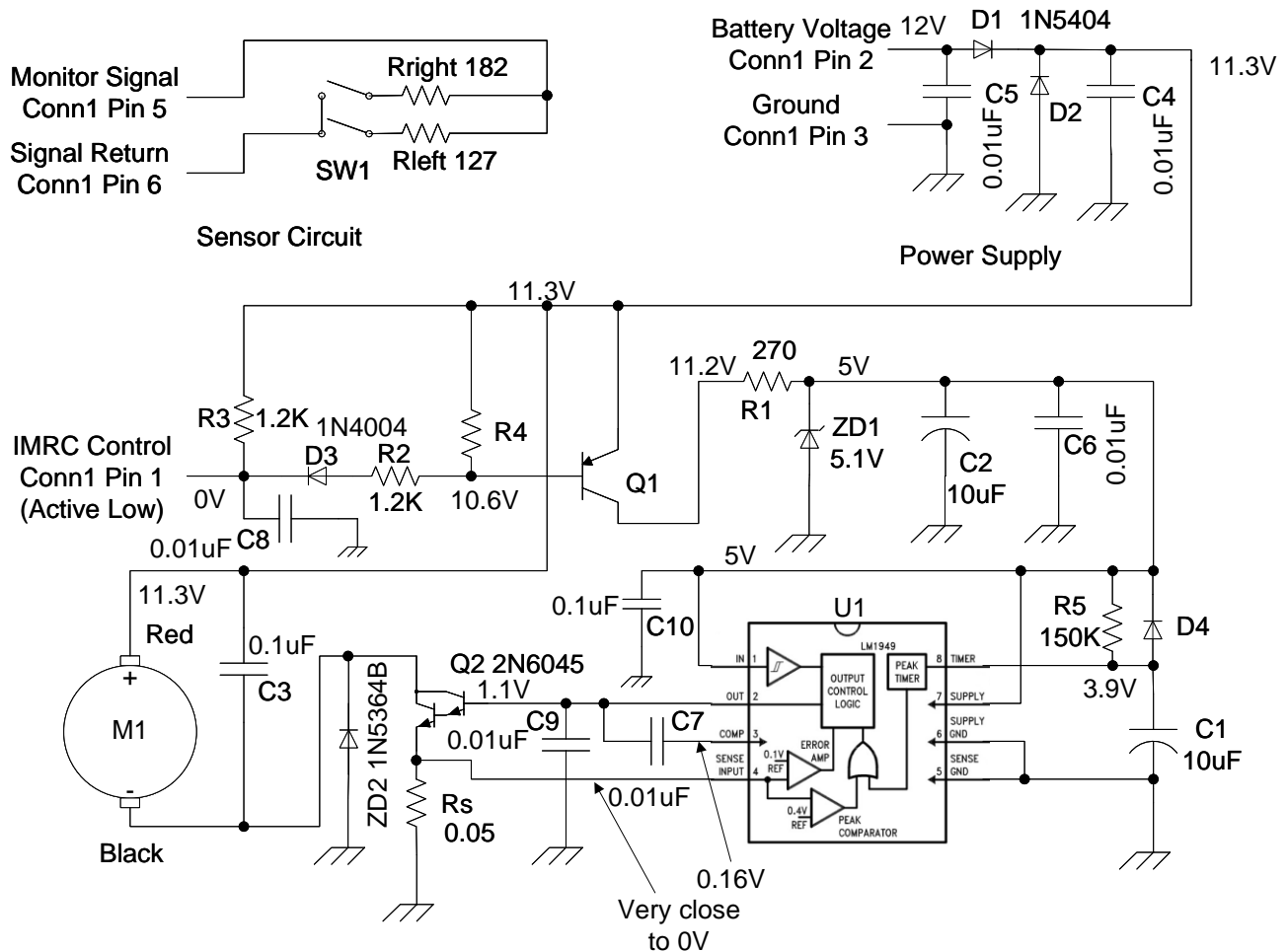

The 5V power not only powers up the injector driver LM1949 IC U1, but it also triggers it to drive the motor. At first, U1 pumps enough current into the base of Q2 to turn it on hard. Q2 effectively grounds the black side of the motor through the 0.05 Ohm current sensing resistor Rs. Q2 provides enough current to start the motor to spin up fast. After the motor spins up, U1 senses it via the current sensing resistor Rs. At that point, U1 drops the current into the base of Q2 to cause it to generate just enough current to hold the IMRC valves open, but no more. That keeps the motor from overheating as it holds the IMRC valves open. With the motor spinning at steady state, U1 keeps the voltage at the base of Q2 at about 1.1V. The voltage at the emitter of Q2 is very close to 0V.

The transition from inrush to holding current happens so fast that we will need a storage scope to capture the signals. The good news is that debug information regarding that transition will probably never be needed to diagnose a broken IMRC Motor Control Unit. I also tried clamping the motor down and clamping the shaft to keep it from turning so as to simulate holding the IMRCs open. But Q2 got very hot, very fast without being heat sunk to the case, so I decided we probably do not need to actually stop the motor to debug the circuit.

Repairing the Cables

The cable sheaths are held in the side of the case with 7/16" C-clips.



Note the cams that open the switches on the PCB when the cables are fully extended

C-Clip:



After the C-clip is removed, the cable sheath slides out of the case.

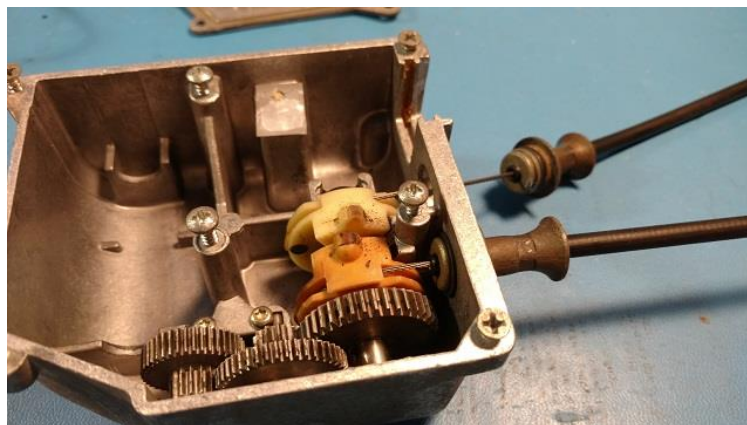

The cable end is glued to the plastic cam. You will need to chip the glue out to free up the cable for removal.

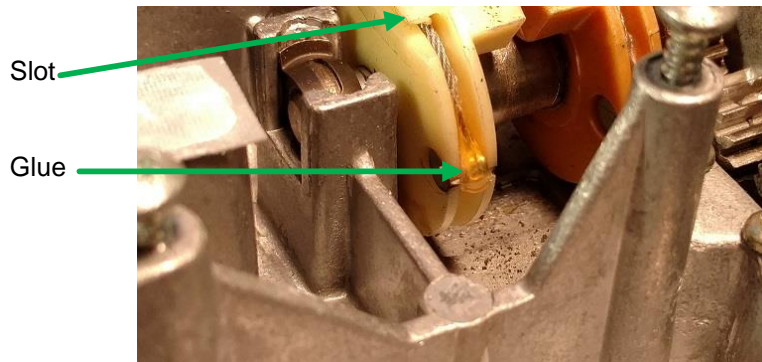

Slide the cable out of the slot on the side of the cam.

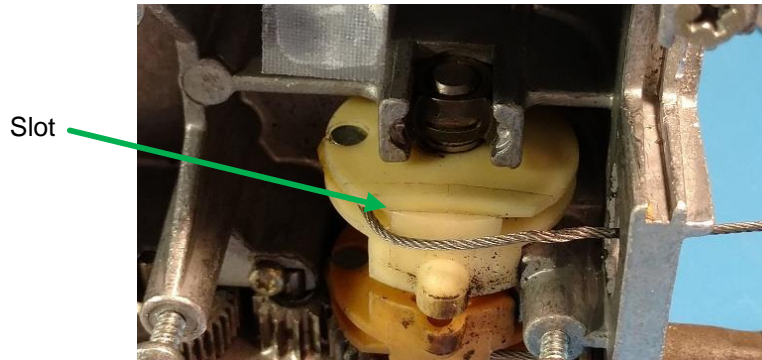

Rotate the cable around its end until it is perpendicular to the cam and then slide the cable end out of the cam. Then the cable is free to be removed from the case. Note the O-ring seal on the cable end.

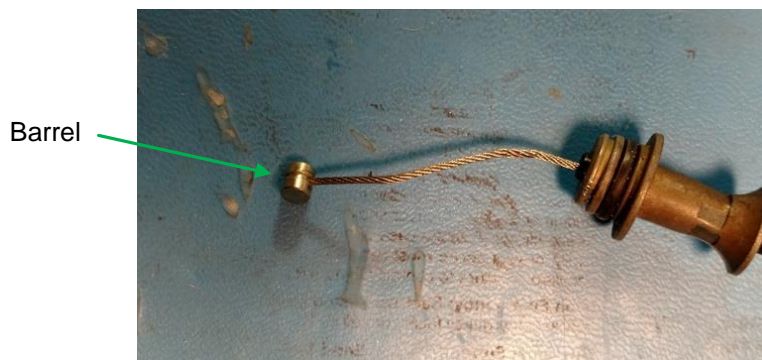

FYI, the inner cable is a 3/64" 7x7 cable made with stainless steel. It is 23-3/16" or 58.9cm long. The cam end of the cable is terminated with a transverse mounted barrel that is 3/16" (0.19mm) in diameter and 7/32" (5.44mm) long. I do not know how the barrel is attached to the cable.

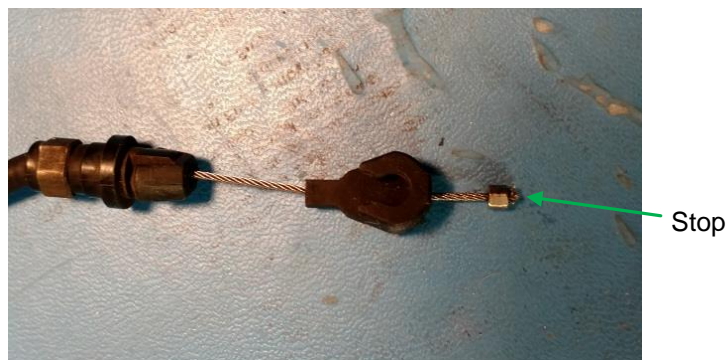

The ferrule is swaged to the end of the cable. Contact me via my web site, www.accutach.com for replacement clips. The replacement clips can be installed without removing the ferrule from the cable. If you need to replace the ferrule, pull the cable all of the way in, install the clip and ferrule with a small amount of slack with the cable fully retracted.

If one or both tabs on the end of the cable sheath are broken, you will need to figure out how to attach the sheath to the lever bracket. There are a couple of work-arounds available for broken tabs. Here's what a sheath looks like with a single broken tab:



If only one tab is broken, you can place the cable sheath into the lever bracket and then run a cable tie under the remaining tab to secure the sheath to the bracket:



If both tabs are broken off, Accutach Co. has sourced a single wire hose clamp that will fit the connector body to hold it in place. Check out www.accutach.com to order the clamp. Here's a photo of a fitting with both tabs gone:



A cable tie will not hold the sheath in place in this case.

Cut a ring groove on both sides of the plastic body so that the hose clamp will snap into the ring groove to hold the cable sheath in place in the bracket. The bracket is about 0.095" thick, so the ring groove needs to be cut a bit past that. The ring groove needs to be wide and deep enough to hold the clamp in place. The hose clamp wire is about 0.06" in diameter:

Ring Groove

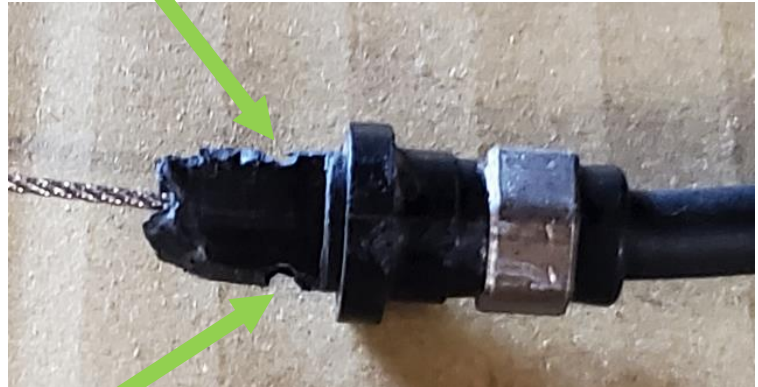
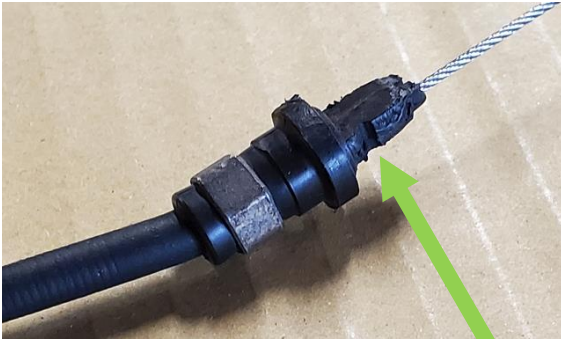

Ring Groove

Wind the clamp onto the inner cable in a way similar to putting a key on a keychain. I used a small flat-blade screwdriver to spread the clamp:

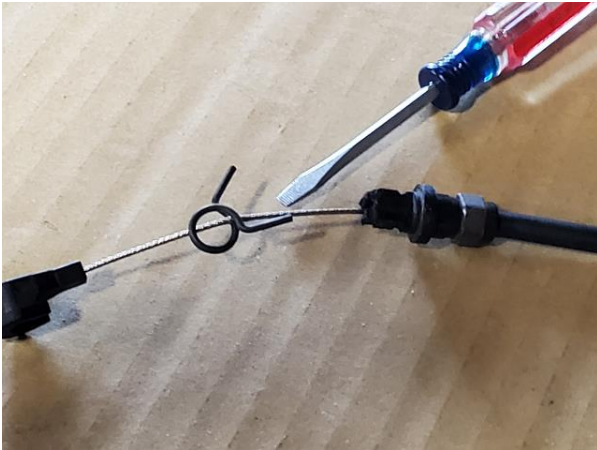

Insert the cable sheath into the lever bracket, compress the clamp and snap it into the ring groove that you cut earlier and the sheath will be secure. It's a bit tricky to do, but it will hold the cable sheath nicely:



Good luck with your repair project. If you are not comfortable with the repairs, Accutach Co. will gladly repair your IMRC controller for you.

Appendix

1996 Diagnostic Trouble Codes (DTCs) from the Emissions Manual:

- P1512 Intake Manifold Runner Control (IMRC) malfunction (Bank #1 stuck closed)
- P1513 Intake Manifold Runner Control (IMRC) malfunction (Bank #2 stuck closed)
- P1516 Intake Manifold Runner Control (IMRC) input error (Bank #1)
- P1517 Intake Manifold Runner Control (IMRC) input error (Bank #2)
- P1518 Intake Manifold Runner Control (IMRC) malfunction (stuck open)
- P1519 Intake Manifold Runner Control (IMRC) malfunction (stuck closed)
- P1520 Intake Manifold Runner Control (IMRC) circuit malfunction
- P1537 Intake Manifold Runner Control (IMRC) malfunction (Bank #1 stuck open)
- P1538 Intake Manifold Runner Control (IMRC) malfunction (Bank #2 stuck open)