

Cruise Button Install

87-14 Mustang Rostra Cruise Control

App Note

Rev. 1.1

© 2023 Accutach Co.

www.accutach.com

This application note describes how to install an Accutach Co. Cruise Button Box and an Auxiliary On/Off into an 87-14 Mustang or a 97-03 F150 with a Rostra cruise control system.

87-04 Mustangs and 97-03 F150s

This app note assumes that you will set the Rostra cruise control system into Open Circuit Control Switch mode.

The steering wheel has 5 buttons: ON, OFF, COAST, SET/ACCEL, and RESUME. The Rostra system has 4 inputs: ON, OFF, SET/COAST and RESUME/ACCEL. The ON and OFF buttons and inputs match, but the other 3 steering wheel buttons need to be mapped to the other 2 Rostra inputs. My customer asked me to map the SET/ACCEL button to the Rostra SET/COAST input and to map the RESUME button to the Rostra RESUME/ACCEL. He asked me to leave the COAST button available for a future mode for his car.

You will need to use an Auxiliary ON/OFF Switch Unit to turn the Rostra cruise control system on and off using the steering wheel ON and OFF buttons. Wire one of the Cruise Button Box Yellow wires to ground and the other to the ON/OFF Switch Unit Green wire. Wire one of the Cruise Button Box Purple wires to ground and the other to the ON/OFF Switch Unit Purple wire. Wire the ON/OFF Switch Unit White wire to the Brown wire on the Rostra connector.

It is a good idea to have a 12V LED or bulb as an indicator for when the cruise control system is on. To do that, connect the positive side of the LED or bulb to the Toggle Auxiliary Box's white wire. Connect the negative side of the LED or bulb to ground.

Put some shrink tubing over the ends of the unused Gray, Orange and Yellow ON/OFF Switch Box wires. This will prevent an accidental short to ground of any of those wires which could cause a fire.

Wire one of the Cruise Button Box Gray wires to switched battery power and the other to the Yellow wire on the Rostra connector. Wire one of the Cruise Button Box Orange wires to switched battery power and the other to the Dark Green wire on the Rostra connector.

You will connect the Cruise Button Box and the ON/OFF Switch Box red wires to switched battery power and their black wires to ground. The red wire on the Rostra connector may be a good source for switched power.

You will connect the Cruise Button Box's blue wire to the steering wheel button signal wire per the Cruise Button Box Install Guide. Be sure to ground the steering wheel button circuit if you have removed the cruise control servo from the car. See the Cruise Button Box Install Guide for details.

The wiring diagram for 87-04 Mustangs and 97-03 F150s is on the following page.

87-04 Mustang or 97-03 F150 Rostra Wiring Diagram

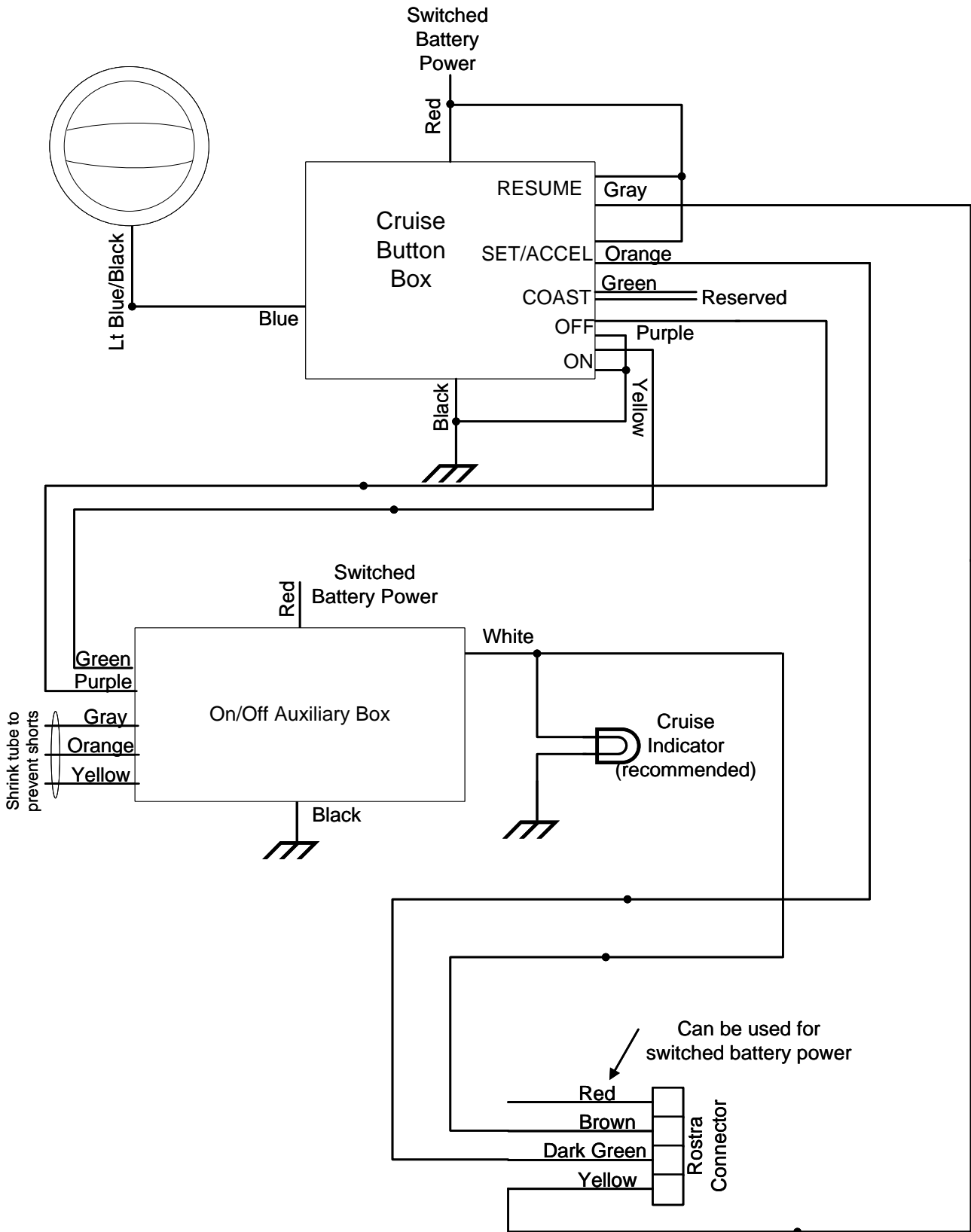

05-09 Mustangs

This app note assumes that you will set the Rostra cruise control system into Open Circuit Control Switch mode.

The steering wheel has 5 buttons: ON, OFF, SET-, SET+, and RSM. The Rostra system has 4 inputs: ON, OFF, SET/COAST and RESUME/ACCEL. The ON and OFF buttons and inputs match, but the other 3 steering wheel buttons need to be mapped to the other 2 Rostra inputs. My customer asked me to map the SET- button to the Rostra SET/COAST input and to map the RSM button to the Rostra RESUME/ACCEL. He asked me to leave the SET+ button available for a future mode for his car.

You will need to use an Auxiliary ON/OFF Switch Unit to turn the Rostra cruise control system on and off using the steering wheel ON and OFF buttons. Wire one of the Cruise Button Box Yellow wires to ground and the other to the ON/OFF Switch Unit Green wire. Wire one of the Cruise Button Box Purple wires to ground and the other to the ON/OFF Switch Unit Purple wire. Wire the ON/OFF Switch Unit White wire to the Brown wire on the Rostra connector.

It is a good idea to have a 12V LED or bulb as an indicator for when the cruise control system is on. To do that, connect the positive side of the LED or bulb to the Toggle Auxiliary Box's white wire. Connect the negative side of the LED or bulb to ground.

Put some shrink tubing over the ends of the unused Gray, Orange and Yellow ON/OFF Switch Box wires. This will prevent an accidental short to ground of any of those wires which could cause a fire.

Wire one of the Cruise Button Box Gray wires to switched battery power and the other to the Yellow wire on the Rostra connector. Wire one of the Cruise Button Box Green wires to switched battery power and the other to the Dark Green wire on the Rostra connector.

Leave the Cruise Button Box WH/OG wire disconnected.

You will connect the Cruise Button Box and the ON/OFF Switch Box red wires to switched battery power and their black wires to ground. The red wire on the Rostra connector may be a good source for switched power.

You will connect the Cruise Button Box's blue wire to the steering wheel button signal wire per the Cruise Button Box Install Guide. Be sure to ground the steering wheel button circuit if you have removed the cruise control servo from the car. See the Cruise Button Box Install Guide for details.

The wiring diagram for 05-09 Mustangs is on the following page.

05-09 Mustang Rostra Wiring Diagram

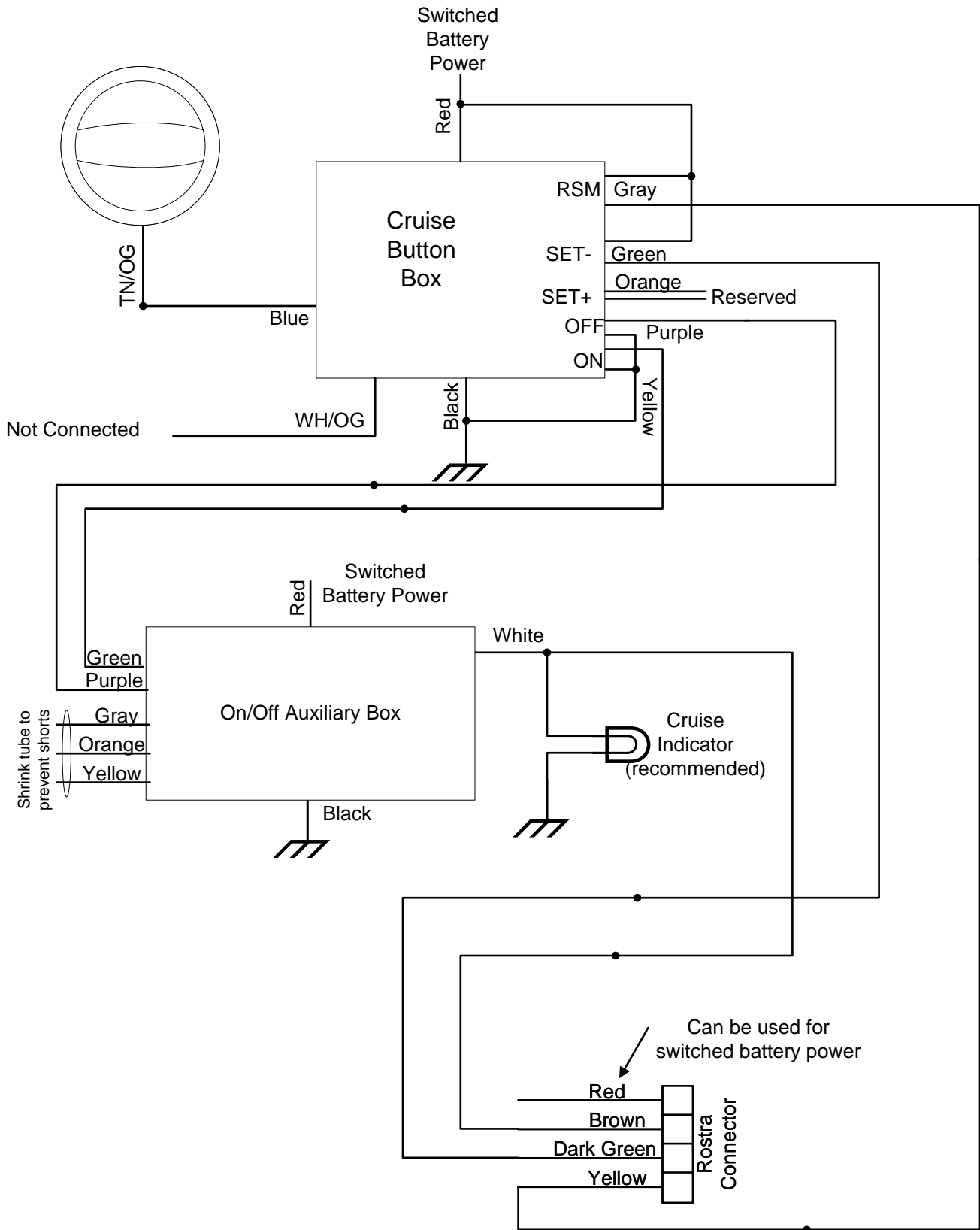

10-12 Mustangs

This app note assumes that you will set the Rostra cruise control system into Open Circuit Control Switch mode.

The steering wheel has 5 buttons: ON, OFF, SET-, SET+, and RSM. The Rostra system has 4 inputs: ON, OFF, SET/COAST and RESUME/ACCEL. The ON and OFF buttons and inputs match, but the other 3 steering wheel buttons need to be mapped to the other 2 Rostra inputs. My customer asked me to map the SET- button to the Rostra SET/COAST input and to map the RSM button to the Rostra RESUME/ACCEL. He asked me to leave the SET+ button available for a future mode for his car.

You will need to use an Auxiliary ON/OFF Switch Unit to turn the Rostra cruise control system on and off using the steering wheel ON and OFF buttons. Wire one of the Cruise Button Box Yellow wires to ground and the other to the ON/OFF Switch Unit Green wire. Wire one of the Cruise Button Box Purple wires to ground and the other to the ON/OFF Switch Unit Purple wire. Wire the ON/OFF Switch Unit White wire to the Brown wire on the Rostra connector.

It is a good idea to have a 12V LED or bulb as an indicator for when the cruise control system is on. To do that, connect the positive side of the LED or bulb to the Toggle Auxiliary Box's white wire. Connect the negative side of the LED or bulb to ground.

Put some shrink tubing over the ends of the unused Gray, Orange and Yellow ON/OFF Switch Box wires. This will prevent an accidental short to ground of any of those wires which could cause a fire.

Wire one of the Cruise Button Box Gray wires to switched battery power and the other to the Yellow wire on the Rostra connector. Wire one of the Cruise Button Box Green wires to switched battery power and the other to the Dark Green wire on the Rostra connector.

Leave the Cruise Button Box WH/OG wire disconnected.

You will connect the Cruise Button Box and the ON/OFF Switch Box red wires to switched battery power and their black wires to ground. The red wire on the Rostra connector may be a good source for switched power.

You will connect the Cruise Button Box's blue wire to the steering wheel button signal wire per the Cruise Button Box Install Guide. Be sure to ground the steering wheel button circuit if you have removed the cruise control servo from the car. See the Cruise Button Box Install Guide for details.

The wiring diagram for 10-12 Mustangs is on the following page.

10-12 Mustang Rostra Wiring Diagram

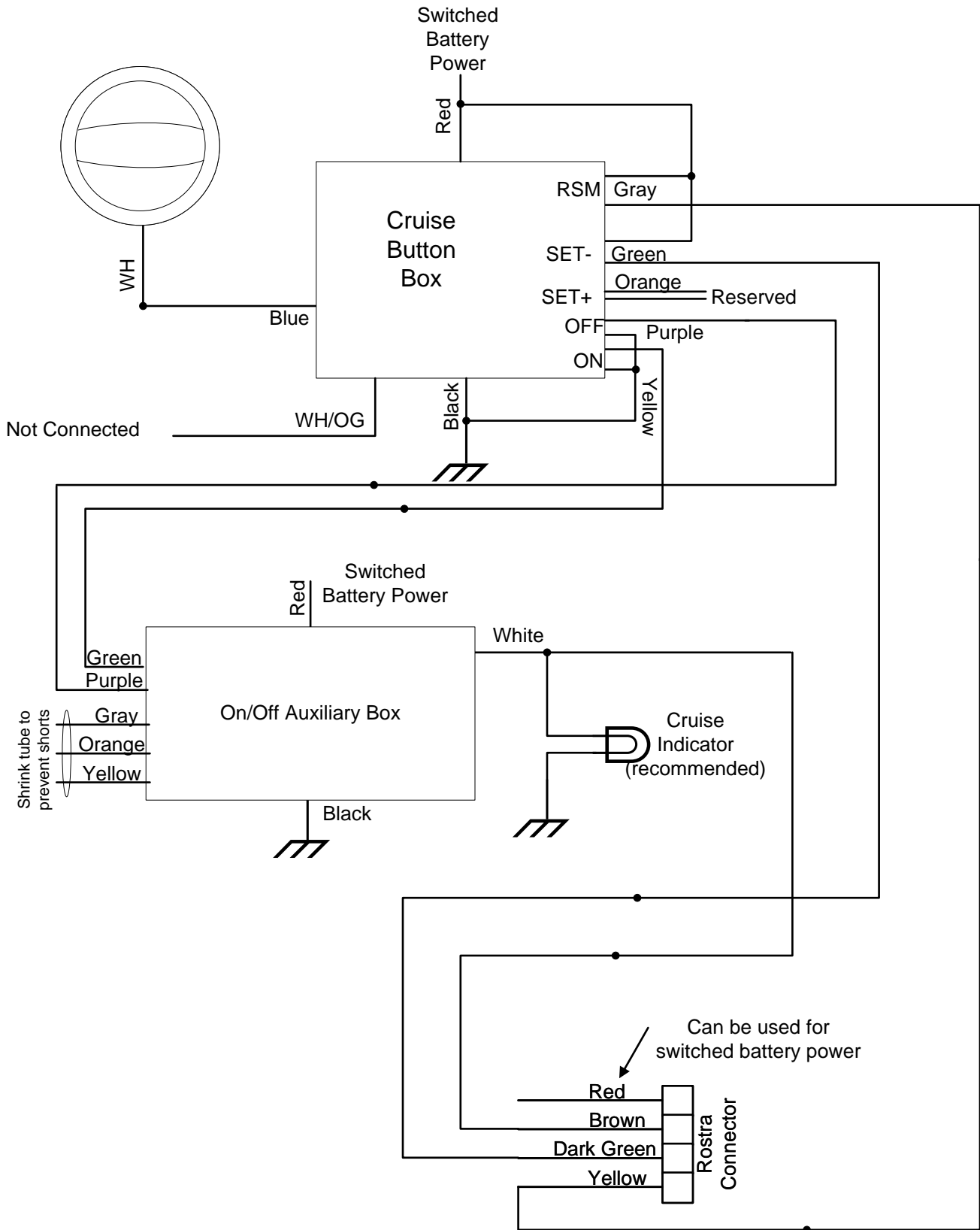

13-14 Mustangs

This app note assumes that you will set the Rostra cruise control system into Open Circuit Control Switch mode.

The steering wheel has 5 buttons: ON, OFF, SET-, SET+, and RSM. The Rostra system has 4 inputs: ON, OFF, SET/COAST and RESUME/ACCEL. The ON and OFF buttons and inputs match, but the other 3 steering wheel buttons need to be mapped to the other 2 Rostra inputs. My customer asked me to map the SET- button to the Rostra SET/COAST input and to map the RSM button to the Rostra RESUME/ACCEL. He asked me to leave the SET+ button available for a future mode for his car.

You will need to use an Auxiliary ON/OFF Switch Unit to turn the Rostra cruise control system on and off using the steering wheel ON and OFF buttons. Wire one of the Cruise Button Box Yellow wires to ground and the other to the ON/OFF Switch Unit Green wire. Wire one of the Cruise Button Box Purple wires to ground and the other to the ON/OFF Switch Unit Purple wire. Wire the ON/OFF Switch Unit White wire to the Brown wire on the Rostra connector.

It is a good idea to have a 12V LED or bulb as an indicator for when the cruise control system is on. To do that, connect the positive side of the LED or bulb to the Toggle Auxiliary Box's white wire. Connect the negative side of the LED or bulb to ground.

Put some shrink tubing over the ends of the unused Gray, Orange and Yellow ON/OFF Switch Box wires. This will prevent an accidental short to ground of any of those wires which could cause a fire.

Wire one of the Cruise Button Box Gray wires to switched battery power and the other to the Yellow wire on the Rostra connector. Wire one of the Cruise Button Box Green wires to switched battery power and the other to the Dark Green wire on the Rostra connector.

Ground the Cruise Button Box WH/OG wire.

You will connect the Cruise Button Box and the ON/OFF Switch Box red wires to switched battery power and their black wires to ground. The red wire on the Rostra connector may be a good source for switched power.

You will connect the Cruise Button Box's blue wire to the steering wheel button signal wire per the Cruise Button Box Install Guide. Be sure to ground the steering wheel button circuit if you have removed the cruise control servo from the car. See the Cruise Button Box Install Guide for details.

The wiring diagram for 13-14 Mustangs is on the following page.

13-14 Mustang Rostra Wiring Diagram

