



VPview®

HYBRID VIEWING TECHNOLOGY

VIEWING PRINTING INSPECTION ANNOTATIONS

VPview offers an affordable, highly efficient solution for viewing, inspecting, redlining, and printing/plotting of 2D CAD and GIS documents, numerous raster, vector, and hybrid formats, such as TIF, DGN, DWG, and RasterDWG. Attractive multi-seat rates offer best value for a fast, easy, and extensive document access.

- Viewing image, CAD, GIS, hybrid data
- Printing to scale, extents, layers
- Inspecting detail, properties, attributes
- Attractive network multi-seat options

Printing, panning, zooming, rotating, and accurate measuring are provided as basic features. Even reviewing properties of selected CAD elements is supported. In CAD drawings the complete layer structure is displayed with on/off switch options for viewing or printing specific layer selections. Even object attributes in CAD files or GIS shapefiles can easily be displayed and inspected with individual query options.

Quick file previews while browsing through directories, fast document loading, and complete zoom and pan features - all provide seamless document handling. Posting text and graphic annotations with „Redlining“ is done by simply picking suitable mark-up symbols and placing them where desired.

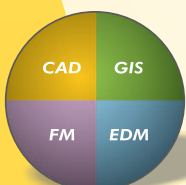
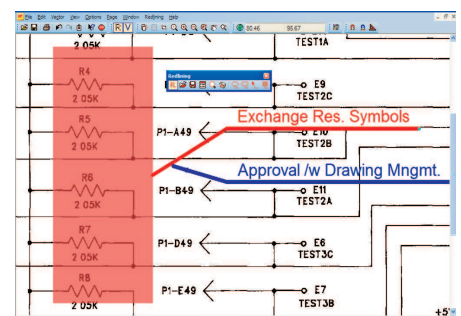
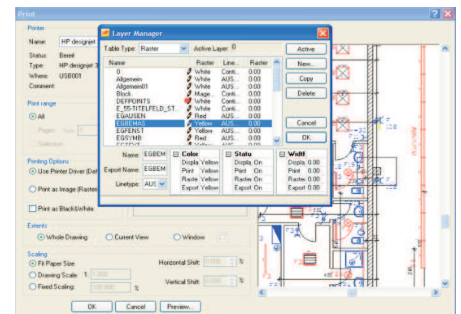
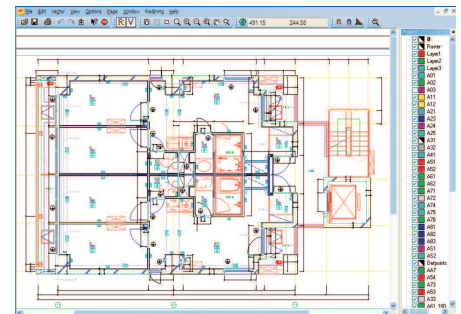

VIEWING PRINTING INSPECTION ANNOTATIONS

VP view[®]
HYBRID VIEWING TECHNOLOGY



Viewing

A vast number of image formats, vector graphics, GIS data sets and hybrid files can be previewed and loaded in a blink. Fast zoom, pan, and rotation functions allow for detailed inspection.

Printing/Plotting

VPview features extensive print and plot functions for raster, vector, and hybrid data. Drawings may be plotted to full extents or with any scaling factor or fraction. The support of AutoCAD plot style tables is included. With full layer control printing individual layer selections is also provided. A print/plot preview allows for exact positioning and window selection.

Measuring/Attribute Inspection

VPview provides exact "on-the-fly" measuring of distances, angles, areas etc. in drawings and maps. Attribute inspection from GIS datasets gives immediate access to meta data in maps with query options.

File Comparison

VPview contains a quick visual comparison of different file versions and drawings. In comparison mode the changes and differences are highlighted.

Annotations/Redlining

VPview offers easy to use pre-designed redlining objects ready to be placed on drawings. A distinctive rights assignment regulates to either view, check, create, or remove redlining elements and annotations for any user in a network environment.

Import Formats

Raster:	TIF (uncompressed: Group3, Group4, LZW, Packbits, Multi-Page), GeoTIFF, PDF, MrSID, JPG, JPEG2000, ER Mapper (ECW/ERS), EDMICS, CALS Gruppe 4, BMP, GIF, PCX, DCX, PNG, Image Systems (IG4/IGS/RLC), Intergraph (CRL, RLE, CIT), TGA, Sun Raster (IM1, IM8, RAS, SUN), GeoSpot (BIL), ERDAS (GIS/LAN), GOE (NOAA/NEDIS GOES), Core IDC, VIF, Landsat/NLAPS FAST-7
Vector:	DXF, DWG, DGN, HPGL/2
Hybrid:	CGM, PDF (limited), DWG, RasterDWG, RVD (native)
GIS:	ESRI (SHP/E00/GEN) MapInfo (MIF/MID)
Redlining:	RLF (native)

File Size

No actual limitations with Raster/Hybrid files

Viewing

Multi Document Interface (MDI), Multi Page Support
Zoom and Pan functions, Rotate quadrantal
Raster/ Vector view selection
Entity properties, Attributes display

Content Comparison

Comparing two documents (raster/vector/hybrid) and difference visualization by colors

Annotations/Redlining

Ellipse, Arrow, Cloud, Transparent Rectangle
Headline and Comment Text
Free Text positioning
User Access and User Rights Configuration

Printing/Plotting

Extents, current view, custom fraction, scale to fit, rotated view
AutoCAD CTB support (plot style tables)

System Environment

Windows Vista / 7 / 8 32bit/64bit

softelec, VPHybridCAD, VPindex, VPmap, VPview are registered trademarks of softelec GmbH, Germany • AutoCAD, RasterDWG are registered trademarks of Autodesk Inc., USA
ESRI is a registered trademark of ESRI Inc., USA • MapInfo is a registered trademark of MapInfo Corp., USA • Windows, Vista are registered trademarks of Microsoft Corp., USA
(c) softelec GmbH E 09- 2018

