

*J. Wright,
Bending Sheet-Metal.*

N^o 14,332.

Patented Feb. 26, 1856.

Fig. 2

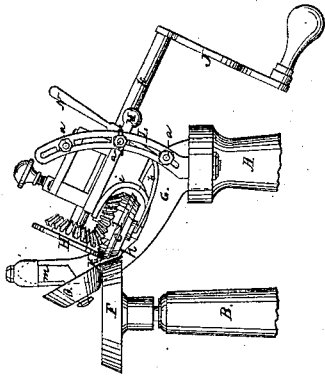

Fig. 1

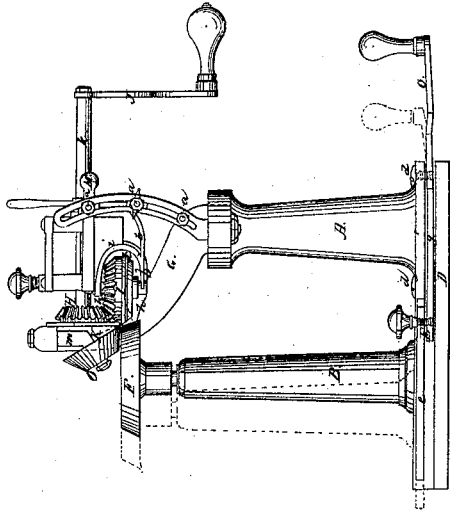

Fig. 6

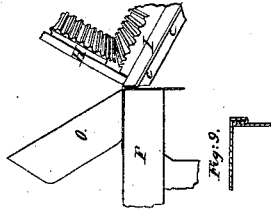

Fig. 3

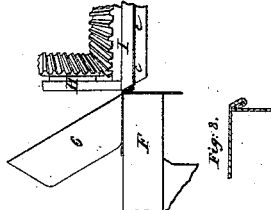

Fig. 4

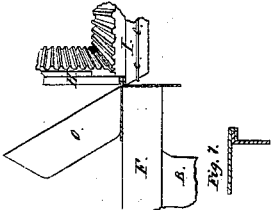
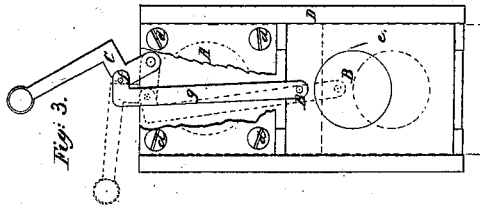

Fig. 3



UNITED STATES PATENT OFFICE.

JNO. WRIGHT, OF HARMAR, OHIO.

IMPROVEMENT IN BENDING SHEET METAL.

Specification forming part of Letters Patent No. 14,332, dated February 26, 1856.

To all whom it may concern:

Be it known that I, JOHN WRIGHT, of the town of Harmar, county of Washington, State of Ohio, have invented a certain new and useful Improvement in Machinery for Setting Down, Seaming, and Grooving Sheet-Iron or other Metal Ware; and I do hereby declare that the following is a full, clear, and exact description of the construction and operation of the same, reference being had to the annexed drawings, making a part of this specification.

Figure 1 is a view of the machine, a part of the frame and connecting-arm removed, (as seen by the dotted lines,) the better to exhibit its principal working part. Fig. 2 is a view of the machine nearly or quite in the position for grooving or finishing the seam. Fig. 3 is a view of the bed-piece, upon which rest the pillars of the machine, with the lever, &c. Figs. 4, 5, 6, are views of a section of the machine, together with sections of the work to illustrate the different operations of the machine, &c. Figs. 7, 8, 9 are enlarged sections of the work as performed by different operations of the machine.

The letters upon Figs. 2, 3, 4, 5, 6 correspond with those upon Fig. 1, marking the same parts of the machine.

In Fig. 1, A is a pillar upon which rests the principal working part of the machine, and is made fast to the bed-piece D by screws *ddd*, as seen in Fig. 3. The pillar B is made fast to a sliding plate, *e*, which works in grooves in the bed-piece D.

F is a rotary disk upon which it is intended the work shall rest, and may be changed for others of any form or size the work may require.

C is a lever, which is attached by a toggle-joint, *f*, to a rod or strap of iron, *g*, passing underneath the pillar A, and made fast by a screw or otherwise to the sliding plate *e* at E, by means of which the pillar B, supporting the rotary disk F, may be brought to or from the working part of the machine at pleasure.

G is a frame which contains the principal working part of the machine and is attached to and may be cast with the pillar A.

The wheels H and I, connected by bevel-gear, and the other principal working part of the machine, are attached to the frame G by two connecting semi-cylindrical arms. (Indicated by dotted lines *h h* and section *i*.) *i* is

the section of one arm cut off, that wheel I may be better seen and described.

The circular dotted line around K represents a bolt on one side of the machine, which, together with like bolt on the other side, connect the two semi-cylindrical arms to the frame G and work as pivots, holding the machine so that it must always work to a common center, as shown in Fig. 1, when the wheel I and the axle *k* of the wheel H are horizontal, and in Fig. 2, where said wheel I and axle-shaft *k* are inclined.

L is a gage made fast to pillar A by nut *p*.

aaa are nuts screwed upon short bolts, upon the inside heads of which are slots to receive the thumb-spring M, which, the bolts being movable, may be set at any point of the gage desired.

M is a thumb-spring which sets into and fits the slotted heads, by pressing in which the working part of the machine may be elevated or depressed to any angle required.

N is a lever connecting with the wedge *b b*, which wedge passes under the shoulder of the wheel I, by means of which the wheel I is elevated or pushed toward wheel H, as seen in Fig. 5, so that point *o* of wheel I runs on the point *o* of wheel H.

O is a rolling bevel-edged wheel attached to the frame G by the axle *m*, and is designed to assist in keeping the work in its proper place upon the rotary disk F.

cc is a bead upon the beveling part of the wheel I, and operates both as a gage to the seam, and, together with the wheels I and H, the rolling wheel O, and rotary disk F, is a perfect grooving-machine, adapted to work upon double seams at any angle or bevel.

The operation of this machine may be described as follows: The edges of the metal vessel to be set down, seamed, and grooved should be first lapped over, as in Fig. 7 but loosely, and then the vessel be placed upon the disk or table F, and it, with the vessel upon it, be brought up by means of the hand-lever C till the edges to be seamed pass between the setting-down wheels H and I, as in Fig. 4, when, by turning the crank J, the wheels H I, and disk F with the vessel upon it revolve, and the seam is perfectly "set down." The disk and work are then drawn back and the lever N drawn out to cause the wedge *b* to press under the shoulder of the wheel I to

slightly raise the said wheel, as indicated by Fig. 5, then the work again pushed forward, when it will be found that the seam pressing against the bevel-edge of the wheel I will be partially turned downward, as shown in Figs. 5 and 8, and by turning the crank J, as before, the seam will be similarly turned down all round. Then press in the thumb-spring M and depress the crank J, and its accompanying parts connected with the swinging frame till they occupy the position shown in Figs. 2 and 6, (if that be the finishing-angle desired for the work,) and secure said parts in said position by the thumb-spring clasping one of the slotted heads *a*, screwed down at its proper set. The seam will then be turned down flat or to its full extent, as represented in Fig. 6, and by turning the crank J as before the double seam be established and perfected all around. The projecting ledge or bead *c c* of the wheel I performs in these operations an important function, as in taking the first bend down of the seam, as in Fig. 5, it acts as a gage to the seam, and, lapping under or clipping the seam, as it were, at the bend of the internal lap, or, if made of sufficient depth, entering far up between the seam and body of the vessel, it prevents the seam as set down by the first operation from "opening" during, as specified, the angular bending of the seam all round, as in Fig. 5, which would not be the case were simple outside pressure resorted to of the wheel I to bend down the seam without this under or interior clip, hold, or bearing of the projecting ledge or head *c c* operating in connection with the bevel or outside acting surface of the wheel I, as specified. In the finishing process of Fig. 6 the same arrangement serves both to fully lay down or close the double seam and put a finishing-groove on it at the edge. All these operations, it will be

observed, are effected without, of necessity, ever removing the metal can or vessel from its table or disk F, and the use of the mallet, which heretofore has been held almost indispensable to form a perfect "double" seam, is rendered unnecessary; but as with all practical machines, so with this, it necessarily follows that much of the principle and many of the details are common to other machines for "setting down," "seaming," &c., and two wheels of different thicknesses, operating in connection with a gage for establishing different widths of seams in single seaming, has been used; also, in other machines for turning a single lap or edge conical rollers have been used, the one roller forming a bearing-surface on the inside and the other roller being operated by lever to bend down the metal by pressure on the exterior, while the metal plate or disk being worked upon was caused to rapidly revolve; but such arrangement could not be adopted for the several purposes or operations my improvement is designed, and are not applicable to double-seaming metal ware in manner described for my improvement.

What I claim as new and useful, and desire to secure by Letters Patent, is—

The combination and arrangement, substantially as herein shown and described, of the setting down, bending, and finishing rollers or wheels H I, with the table or disk F, for operation together and in relation thereto and each other, in the manner and as specified, the one wheel I having a projecting ledge or bead for the purpose of gaging the "double seam" and clipping, or holding it from opening while being bent, essentially as set forth.

JOHN WRIGHT.

Witnesses:

JACOB WELLS,
CHAS. MOAT.