

H. J. Moyes.

Seaming Tin-Ware.

N<sup>o</sup> 73636

Patented Jan. 21, 1868

Fig. 1

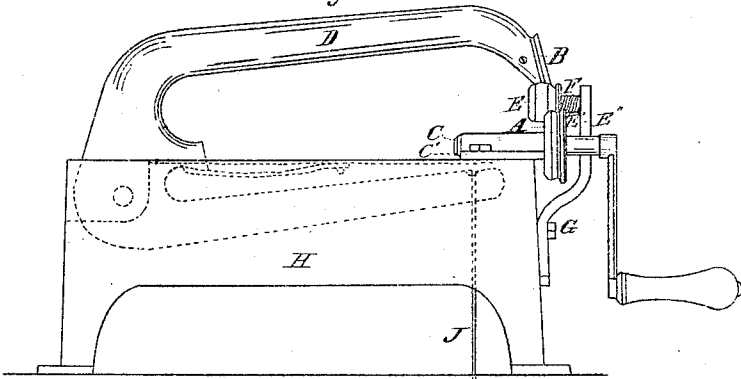

Fig. 2

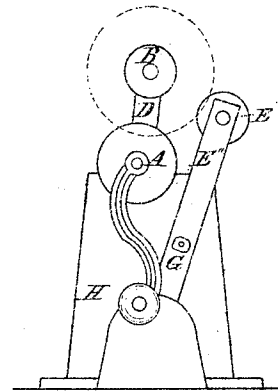

Fig. 4

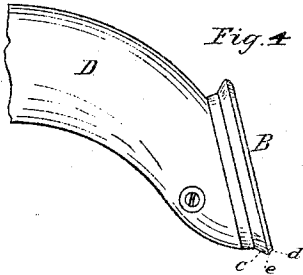

Fig. 6

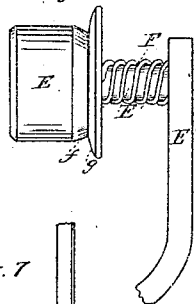

Fig. 3

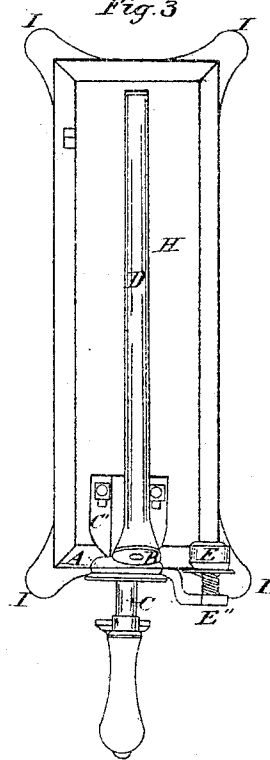

Fig. 5

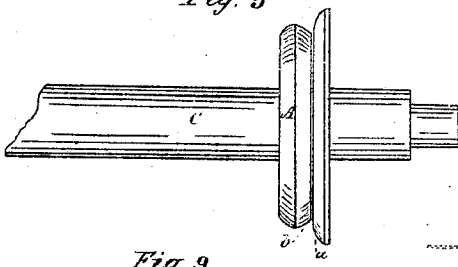

Fig. 7



Fig. 8

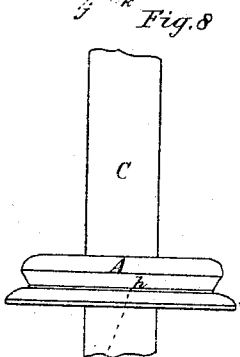

Fig. 9

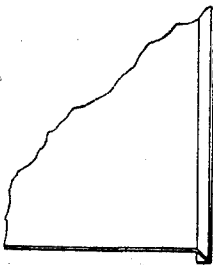
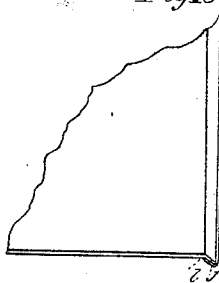
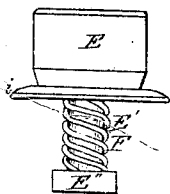

Fig. 10



Witnesses  
J. F. Single  
Franklin Rogers.

Inventor  
H. J. Moyes.



# United States Patent Office.

H. J. NOYES, OF ASHTABULA, OHIO.

Letters Patent No. 73,636, dated January 21, 1868.

## IMPROVEMENT IN TIN-WARE SEAMING-MACHINE.

The Schedule referred to in these Letters Patent and making part of the same.

### TO ALL WHOM IT MAY CONCERN:

Be it known that I, H. J. NOYES, of Ashtabula, in the county of Ashtabula, and State of Ohio, have invented a new and improved Single-Seaming Machine for making an improved seam on the bottoms of tin-ware articles; and I do hereby declare that the following is a full and exact description thereof, reference being had to the accompanying drawings, in which—

Figure 1 is a front elevation of my said machine,

Figure 2 an end elevation, and

Figure 3 a plan view of the same.

Figures 4, 5, and 6, detailed portions, represented on an enlarged scale.

Figures 7 and 8, diagrams illustrating the working principle of said details; and

Figures 9 and 10, partial forms of the body and bottom of a fruit-can before and after seaming.

The letters of reference marked thereon refer to similar parts in all the figures.

This invention has for its object an improved mode of closing the seams of the bottoms of tin-ware articles, and is particularly applicable to fruit-cans, and other ware about which some degree of certainty is necessary to know that the seam is perfectly air-tight. The condition of the seam made by this machine is such that the faces of the turned edges of the bottom and body are in perfect contact all around, so much so that the article is, under ordinary circumstances, water and oil-proof without soldering. In any case, whether the article is designed to be water, oil, or air-proof, there is great saving of solder, from the fact that the joining is so perfect that there are no holes left in the seam for it to run through in the operation of soldering; and from the peculiar mode of turning the seam, as will be explained, the sharp angle or corner of the bottom is left unbroken in every instance. This defect is very liable to occur in seaming with the machines now in use, and therefore requiring an additional application of solder.

The closing of the seam is effected expeditiously, and, with ordinary attention in soldering, will leave no doubt as to its being air-tight. In other methods of closing the seam, the workman has to depend on chance for this feature, or else bestow an extra amount of attention on his work, which, in the rapid handling of hundreds of the same article, (as fruit and preserve-cans,) is apt to prove irksome and create negligence.

My improved mode of closing the seam is due mainly to the particular construction of the rotating pressure-head, hereinafter described, and to its peculiar action on the turned edge of the bottom, so that a perfect contact of the turned edges of the body and bottom of the ware is thereby secured, and all danger of cracking the plate at the sharp angle of the bottom is entirely avoided.

The general form and construction of the whole machine is given in figs. 1, 2, and 3, a detailed description of which is not deemed necessary. Those parts only will be described that are essential to the accomplishment of the improvement under consideration.

A, fig. 5, is a rotating "seaming-head," having its periphery constructed with faces *a* and *b*, the former rounding, and the latter flat, the face *b* presenting an acute angle to a portion of the face *a*, substantially as shown in the figure. The said rotating "seaming-head" is fixed to a short revolving shaft, C, fig. 1, which has its bearing in a slotted box, C', fig. 3. B, fig. 4, is a rotating "pressure-head." The edges of this are provided with faces *c* and *d*, both faces being flat, and stand to each other at an obtuse angle, as seen, the point of the angle being slightly rounded off. Said head is placed on the forward end of the vibrating arm D, fig. 1, so as to rotate in an inclined direction, as shown. E, fig. 6, is an adjustable rotary-gauge pressure-head, placed on a fixed shaft, E', on the support E''. Said head is constructed substantially as shown in the fig. 6. The faces *f* and *g* are formed as therein delineated, *f* being flat, and *g* convex or rounding. Pressure is given to it by means of the spring F.

The relative position of the said-described rotating heads is readily seen in figs. 1, 2, and 3; and I have been thus minute in the description and delineation of the forms of the "faces" on the peripheries of the different rotating heads, as they are absolutely necessary in perfecting the seam on my said improved plan. I will now explain the manner of operating my said machine.

In the first place, the edges of the bottom and body of the article are turned in the usual manner, the

former at a right angle, and the latter flaring or obtuse, as shown in fig. 9. The bottom is then sprung on on the body, and placed on the vibrating arm D, fig. 1, of the machine, in the position seen by the dotted lines in fig. 2, and resting on the seaming-head A. The arm D is then depressed by applying the foot to the tread attached to the rod J, depending from the bent or return portion thereof, shown in the dotted lines of fig. 1. This brings the inclined pressure-head in contact with the inside of the article to be seamed. It will be observed that in depressing the said head, its point *e*, fig. 7, (which is where the pressure commences,) strikes the turned edge of the bottom at *j* away from the sharp corner *k*, as seen in the fig. 7. Motion is then given, by turning the hand-crank, to the seaming-head A, which is communicated to the two others, B and E, and the turned edges before spoken of pressed together in the direction from *j* to *l*, fig. 10. After a sufficient number of turns the article is seamed, and it is then removed from the machine.

As the pressure-head B, under this peculiar arrangement, does not touch the point of the angle spoken of, it will be seen that the seam can therefore be subjected to any number of revolutions, so that the faces of the said turned edges can be brought in the closest possible contact without injury to the corner of the seam. With the old method of seaming, every tinsmith knows he cannot go beyond one, or one and a half revolution without liability of cracking the plate at the said corner. The adjustable-gauge pressure-head E is designed to hold the article to be seamed in such a way that it will, whilst being rotated, tend to keep it, by means of the spring F, inclined in the direction of the dotted lines *h i*, fig. 8, for the purpose of crowding or pressing the bottom tight against the body just preceding the act of closing the seam. The support E'', fig. 2, which sustains the said head E, can be moved in or out by loosening the bolt G, so as to adjust the said head E to the diameter of the article to be seamed. The machine is compact and portable, the body H being supported on short feet I I I I, by which it can be secured to the work-bench.

I am aware that rotating heads or burrs, having various configurations on their peripheries, are in use in machines employed by tin-smiths for a variety of purposes, some of which are used for "seaming" the bottoms of cans; pails, pans, and other tin-ware articles. Such rotating heads or burrs, in themselves, therefore, I do not lay claim to, nor to the seam or joint made or produced by any of them. My invention is confined to the new and improved "faces" given to the peripheries of rotating heads, for the purpose of producing a new and improved seam possessing the peculiar features herein set forth.

What I claim to have secured to me by Letters Patent is—

1. The adjustable rotating-gauge pressure-head E with the spring F and support E'', constructed and operating substantially as specified.
2. The inclined rotating pressure-head B, when constructed substantially as shown, and operating on the seam of the ware in the manner stated.
3. The rotating seaming-head A, and slotted bearing C', constructed and operating as described, in combination with the said pressure-head B, and adjustable-gauge pressure-head E, as and for the purpose specified.

H. J. NOYES.

Witnesses:

J. F. SINGLE,  
FRANKLIN ROGERS.