

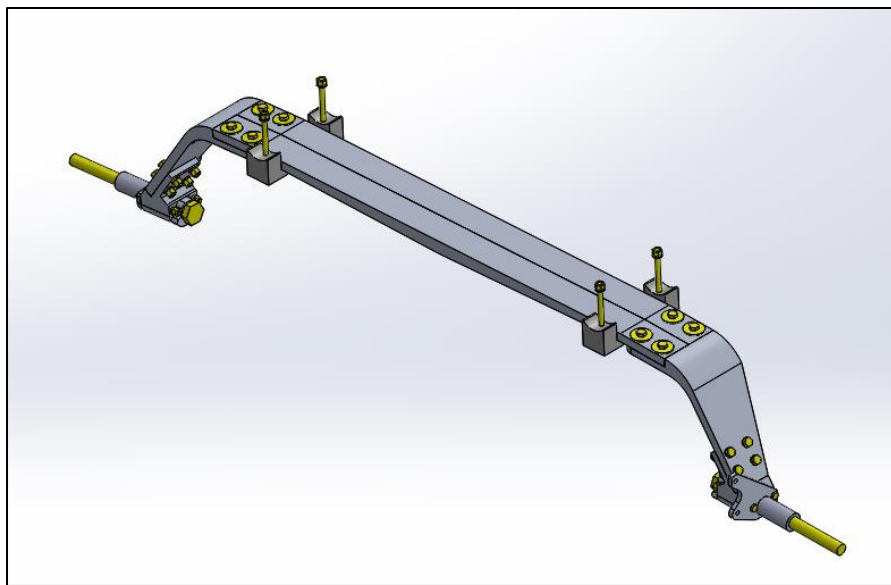

SLAB / SPRING GEAR MANUAL



Phantom Aeronautics LLC

Three Rivers, MI 49093

PH: 616-610-6597

EMAIL: erik.pederson@att.net

Version 5.27.2024

Kit List

MAIN LANDING GEAR ASSEMBLY				
2	AXLE BOLT		Axle Bolt	
4	AN3-26A		3/16" Bolt	
16	AN4-13A		1/4" Bolt	
2	C06		Axle Spacer	
2	C16SL		Axle Housing	
1	C17LDB_SL		Left Brake Caliper Mount Plate	
1	C17RDB_SL		Right Brake Caliper Mount Plate	
2	C19SL		Support Clamp	
2	C21SL		Cross Bar	
1	C22SL_LEFT		Leg Extension Left	
1	C22SL_RIGHT		Leg Extension Right	
4			Rubber Pads	
4	N3		3/16" Nut	
4	W3		3/16" Washer	
20	N4		1/4" Nut	
20	W4		1/4" Washer	
16	W4B		1/4" Fender Washer	

Introduction

This manual provides details on how to install the slab gear onto a new Phantom or retrofitting it onto an older Phantom. This landing gear will fit all versions and years of the single seat Phantom. This landing gear is 7 inches wider than the tube gear. On existing aircraft remove all components associated with the tube gear including the bungee's and spacers associated with the bungees. This hardware is no longer needed.

Key Points

- 1) **When installing the two cross bars that connect the left side of the gear to the right side of the gear the flat side should be facing up. The leg extensions will angle downward slightly causing the wheels to be canted slightly without any load on them.**
- 2) The C19SL Support Clamp bolts to the cage rails using existing bolt holes. The front hole of the C19SL should use the same hole that is used to bolt the C13 solid spreader bar in place. Remove the existing bolt and use the longer bolt supplied with the kit to bolt the Cage Rails, C13 Spreader Bar and C19SL into place. The rear hole of the C19SL will use the rear hole of the previous tube gear clamp block.
- 3) Notice which way the landing gear legs slope. The C22's are sloped such that the axle will be placed as far aft as possible. This is clear in the following images.
- 4) The installation is almost a mirror image left to right with the exception of the C17LDB_SL and C17RDB_SL brake caliper mounting plates.

Right Side of Landing Gear

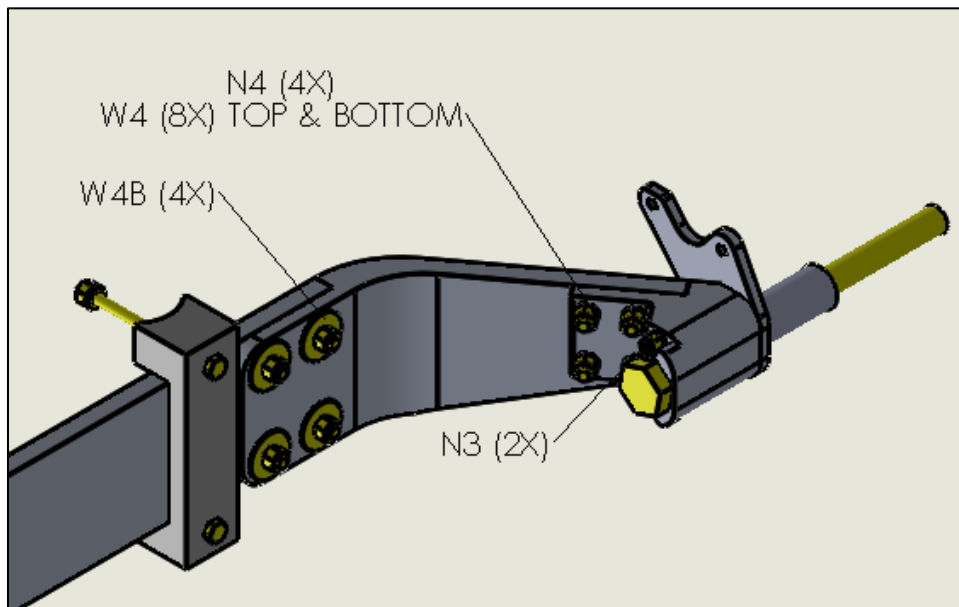
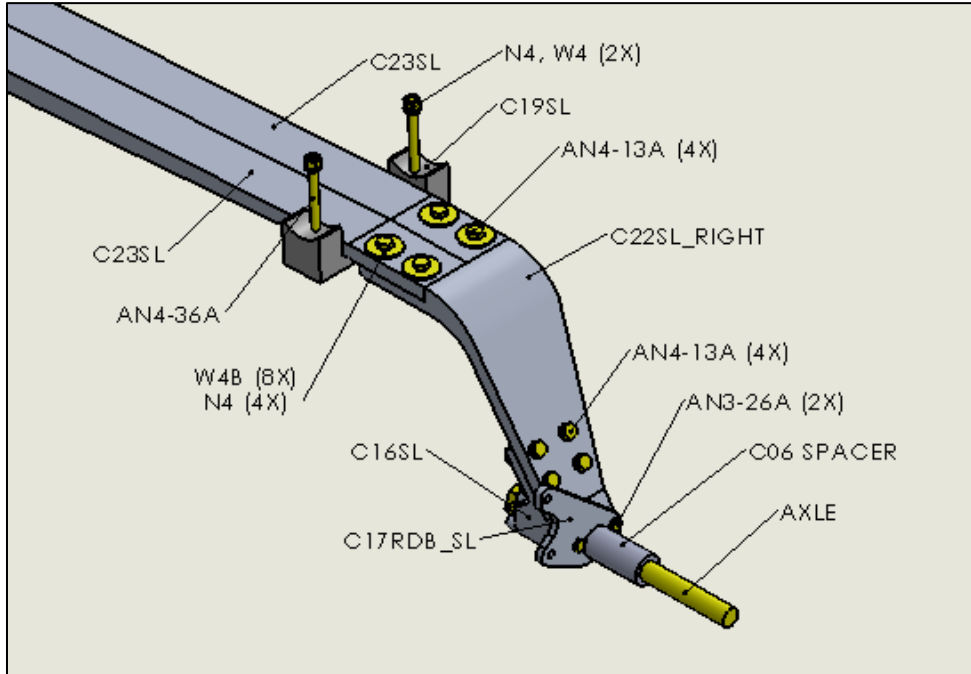

Left Side of Landing Gear

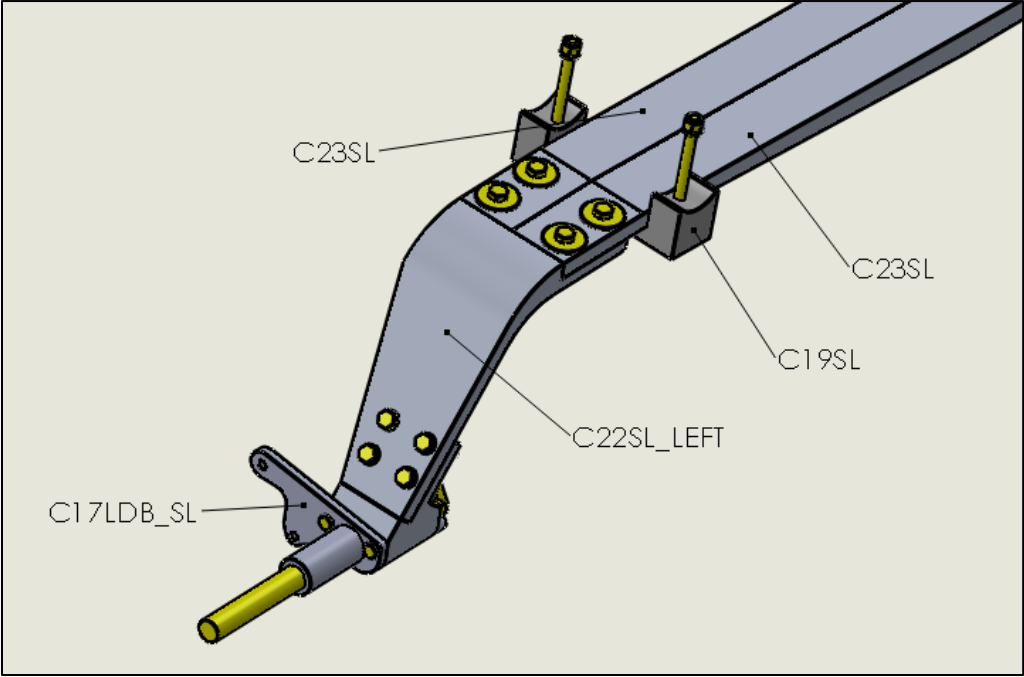

Rubber Wear Surface Installation

A strip of adhesive backed rubber was provided with the kit. This strip should be cut into 4 equal length pieces. These will be adhered to the upper and lower surface of the C21SL slab. Install a piece on the left and right side such that there is a piece of rubber between the C21SL and the C19SL as show in the picture below. Directly opposite of this location install the rubber such that it will reside between the C21SL slab and the cage rail. These pieces are utilized to allow movement between the cage and the landing gear leg as it flexes.

Center the landing gear on the cage and tighten all bolts into location.

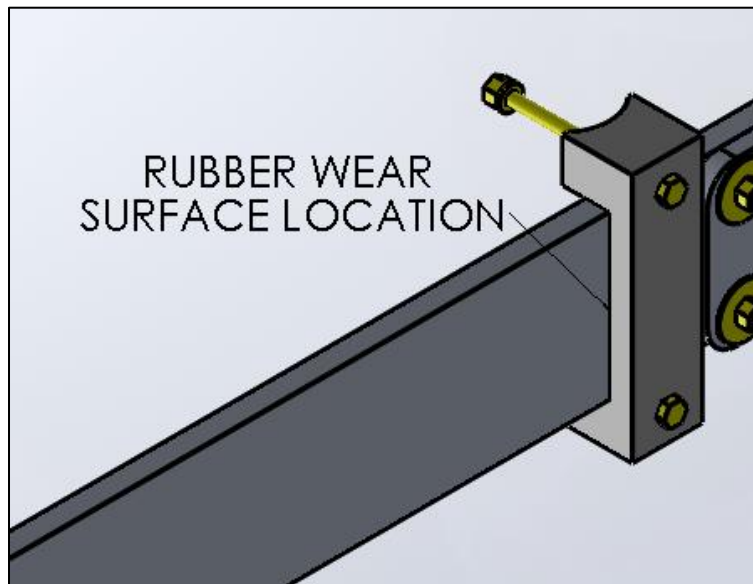

Wheel and Axle Installation

The axles are provided with the kit and should match the tires on your aircraft. If not here is the combination of axle bolt, spacer, washers and nut to match to your setup. The washers are used to space the rim correctly for brake caliper installation. Refer to disc brake installation manual for more information on how to install the calipers.

	Spacer	Axle Length Minimum (inches)	W10 Washers between spacer and rim	Washer under nut	Washer Under Bolt Head
18" Tundra Tires, 6" Rim & Slab Gear	C06B	9.25	2	1	0
12" Tires, 6" Rim & Slab Gear	C06D	8.25	1	1	0
18" Tundra Tires, 6" Rim & Tube Gear	C06B and C06C	8.25	1	1	1
12" Tires, 6" Rim & Tube Gear	C06B	7	0	1	0

As always feel free to call the factory if you have questions.