

Absence of Voltage Tester

The Absence of Voltage Tester (AVT) is a permanently mounted safety device to verify the de-energized state of an electrical panel prior to opening the door.



The Absence of Voltage Tester (AVT) enables qualified personnel to verify the absence of voltage with a push of a button in front of the device and provides an active indication when the absence of voltage is confirmed. The indicator module is designed to fit in a standard 30mm pushbutton hole, and the isolation module is designed to mount on a standard DIN rail or surface mounted using screws.

⚠ Read this document in FULL before installation and operating this device:

- ⚠ To reduce the risk of injury, user must read instruction manual.
- ⚠ Updates or revisions may be issued with or without prior notification. Users should consult the company website for the most current version.
- ⚠ Product must be installed as per the instructions provided in the manual.

- ⚡ For assistance with installation/ operation OR troubleshooting, please contact our technical support team.

Email Support: customersupport@nukleustek.com
Follow Us: [LinkedIn](#) | [Twitter/X](#) | [Facebook](#) | [YouTube](#)

⚠️ Ensure that power is completely disconnected before installing this device.

⚠️ WARNING

Safety and Installation Instructions – Nukleus AVT

- Always de-energize power sources before opening or accessing any electrical enclosure. Strictly follow all applicable safety procedures and lockout/tagout (LOTO) protocols when working on or near energized electrical systems. The Nukleus AVT is designed to complement – not replace – LOTO procedures. It specifically addresses the absence of voltage verification step and must be used in conjunction with approved LOTO practices.
- Wear appropriate personal protective equipment (PPE) whenever working in proximity to hazardous electrical energy.
- Do not operate this product outside the specified performance ratings or environmental limits.
- Installation and commissioning of the Nukleus AVT must be performed only by a qualified electrical worker familiar with local and national electrical codes. The device verifies absence of voltage only at the installed point in the circuit. If additional power sources exist within the equipment, hazardous voltage may still be present.
- **Important:** The absence of illuminated RED “voltage present” indicator LEDs alone does not confirm a de-energized state. A safe absence of voltage is confirmed only when the GREEN indicator LED illuminates at the installed point.
- Ensure the AVT is properly installed and grounded in accordance with this instruction manual to provide accurate absence of voltage indication. Sensor leads must be connected as per the wiring diagram prior to initiating the test to verify the integrity of the sensing circuit. Verify proper operation after installation – see the Commissioning Checklist for more information.
- Trim excess sensor lead length. Do not extend leads by splicing. When using terminal-row power distribution blocks, the total sensor lead length between the isolation module, and the source conductor must not exceed 10 ft (3 m). Leads with the same label designation must terminate on the corresponding conductor (L1, L2, L3, GND). Each conductor should have at least one dedicated lead set, as shown in the wiring schematics.
- Always comply with all applicable local installation codes and standards.

⚠️ Battery and Indicator Module Safety:

- The indicator module contains a lithium battery that poses fire, explosion, and burn hazards. Do not crush, recharge, disassemble, incinerate, expose to heat above 85 Deg and water.
- Use only a Nukleus-approved battery; the AVT will not function with standard 1.5 V AA alkaline batteries.
- Only use the approved AVT system components supplied (Interconnect harness cable, isolation module, indicator module, and battery). Do not substitute the interconnect harness cable with any other component.
- Battery, gaskets, and O-rings are user replaceable. Do not tamper or attempt to open the indicator module and isolation module. Dispose and recycle the batteries as per local regulations for lithium batteries.
- Install the AVT Interconnect harness cable assembly, including integral O-rings in accordance with Nukleus installation guidelines. Ensure O-rings are properly seated in the indicator module before closing the front cap.
- The interconnect harness cable is high impedance to minimize EMI risk. Secure sensor leads properly during installation to ensure intended system performance. Avoid bending the interconnect harness cable greater than a 1-inch radius and secure it to the enclosure or other rigid structure to prevent vibration-related movement.
- The Nukleus AVT must not be installed in series with ESD- or HIPOT-test systems, or on systems that generate high-frequency energy emissions causing EMI.

Nukleus is not responsible for damage resulting from use outside the intended application or from improper installation. For questions regarding product safety functions, contact Nukleus directly. Product model and serial numbers are printed on the isolation module and indicator module labels.

Manual Contents

- Introduction / Product Overview
- Safety information & general warnings
- System Configurations
- Schematics & Wiring Diagrams
- Technical Specifications
- Product Dimensions
- Labels
- Installation considerations
- Installation instructions
- Commissioning checklist
- Operating instructions
- LED Indications
- Troubleshooting guide
- Maintenance
- Warranty information

THE SYSTEM COMPONENTS ARE LISTED BELOW:

Indicator Module

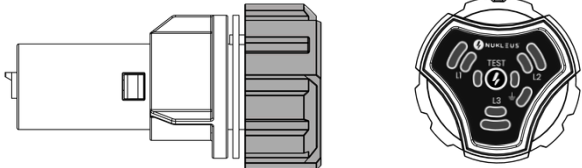

Battery

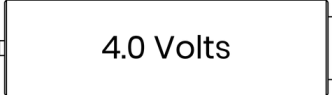

Isolation Module

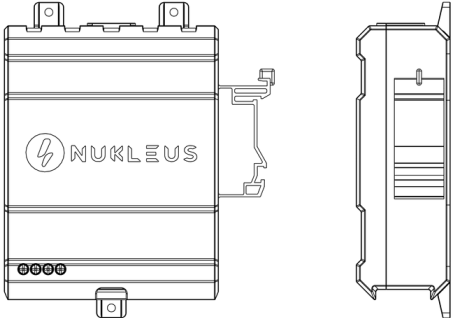

Interconnect harness Cable



The following diagram illustrated below supports three-phase four-wire AC systems and single-phase three-wire AC systems, wiring configurations. Indication behavior depends on the system topology:



AVT Lead Connection Instructions

⚠ WARNING

- Install and ground the AVT exactly as specified in the instruction manual to ensure accurate absence of voltage indication. Sensor leads must not be mechanically connected together. Verify correct operation after installation (see commissioning checklist section). Failure to follow these instructions may result in product failure, serious injury, or death.
- Sensor leads of the same color must be terminated on the same conductor. Each conductor must have at least one set of sensor leads, as shown in the schematics.
- If a sensor lead detaches and contacts a low-impedance ground path, the connectivity test may be compromised, causing a false absence of voltage indication. Secure all sensor leads properly to the power conductor or a nearby rigid feature to prevent movement if a termination fails to remain intact.

⚠ **NOTE** AVT leads shall be connected individually to the corresponding supply conductors, as shown in Figure 1.

⚠ **NOTE** To maintain the redundancy of the connections it is important that the leads are not connected together, as shown in Figure 2.

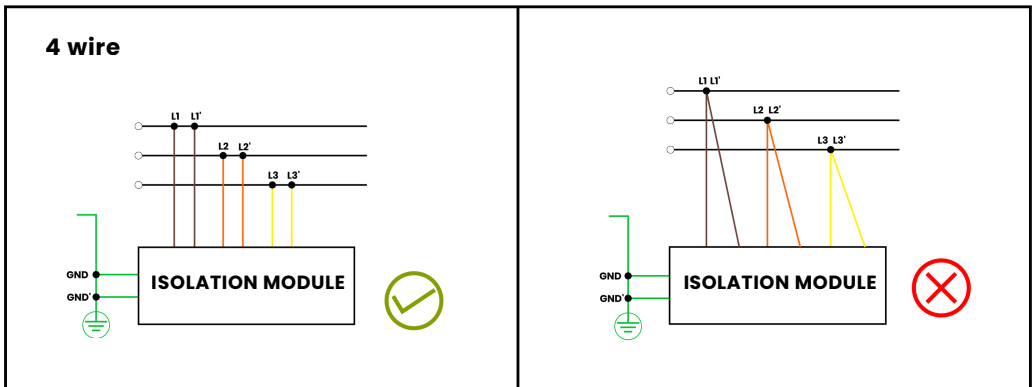

The following diagrams illustrated below show supported systems wiring configurations. Indication behavior depends on system topology and available conductors:

THREE PHASE WYE, 4 WIRE (3 WIRE + GND)

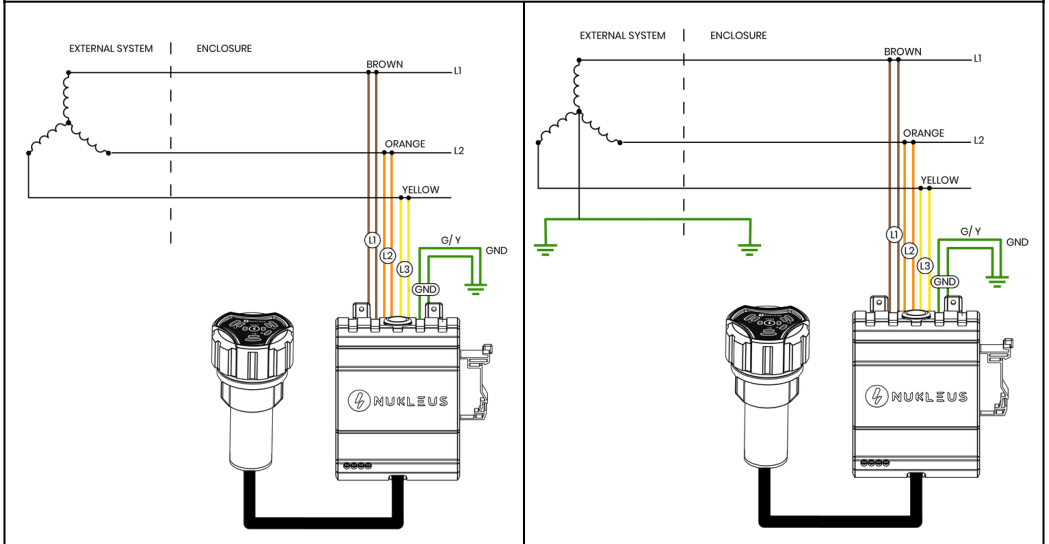

THREE PHASE DELTA, 4 WIRE (3 WIRE + GND)

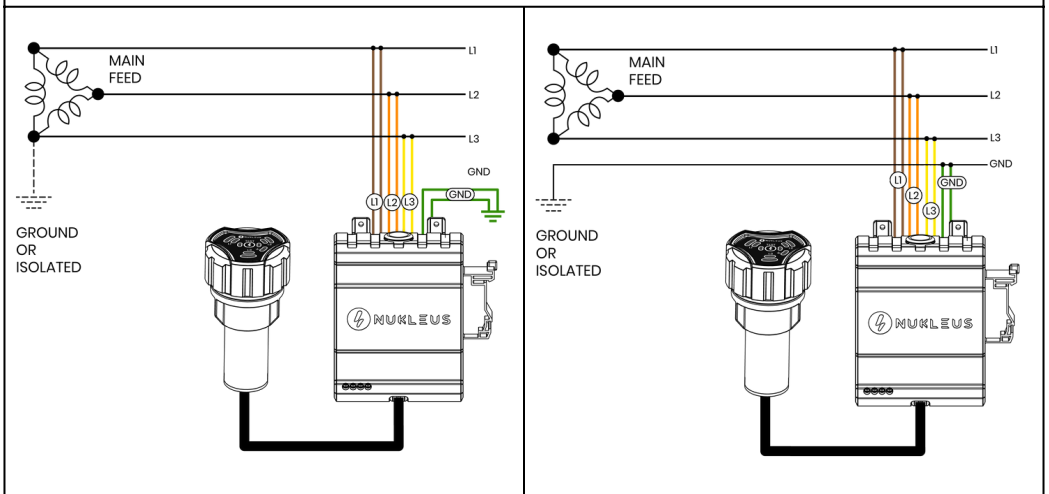

The following diagrams illustrated below show supported systems wiring configurations. Indication behavior depends on system topology and available conductors:

SPLIT PHASE, 3 WIRE + GND

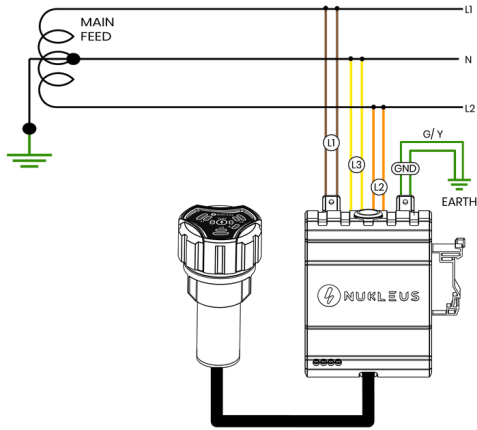

CORNER DELTA, 3 WIRE

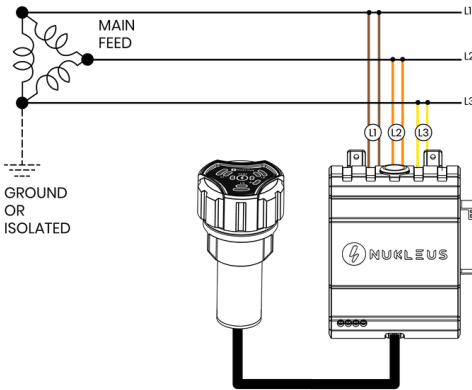

CORNER DELTA, 3 WIRE + GND

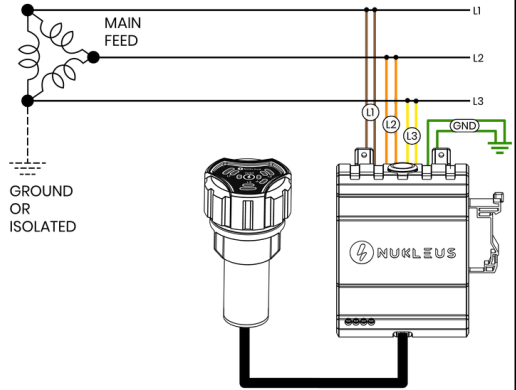

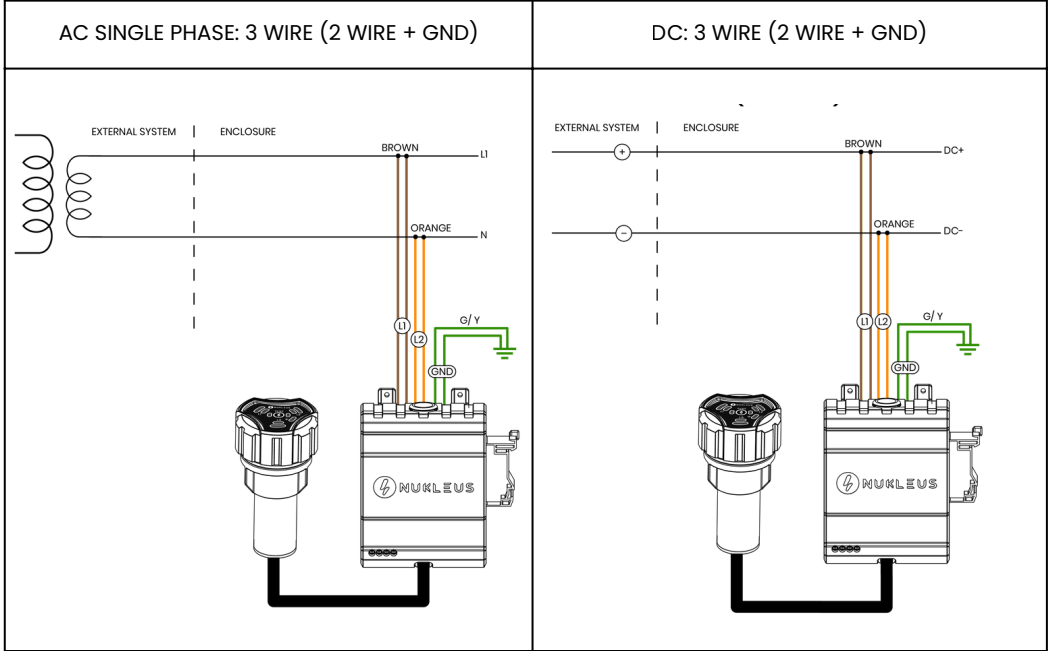

Specification	Details
Electrical System	For use in three-phase and single-phase AC
Voltage Detection Range	Up to 1000 VAC (50/60/400 Hz)
absence of voltage Threshold	Less than 3 volts AC
Overvoltage Category	Category III (1000 V), Category IV (600 V)
Operating Temperature	-25 °C to 55 °C
Storage Temperature	-45 °C to 80 °C
Humidity	5 to 90% non-condensing; Rated 80% at 40°C (104°F), decreasing linearly to 50% at 60°C (140°F)
Altitude	Up to 2000 meters (6600 feet)
Pollution Degree	2
Terminations	8 wire leads – 2 per line: 8 ft, 14 AWG, 90 °C @ 1000 V, UL 1032, PVC-insulated with nylon jacket
Indicators	<ul style="list-style-type: none"> • 3 large RED LEDs for L1, L2, L3 to indicate presence of voltage. • 4 small RED LEDs for L1, L2, L3, and GND to indicate disconnected leads. • 1 AMBER LED for unsafe voltage and hardware faults. • 1 GREEN LED for safe voltage.
Degree of Protection	Indicator module: Designed to be mounted on a flat-surface or standard DIN rail in a Type (UL, NEMA, and CSA) 1, 12, 13, 4, 4X, IP66, IP67, or IP69 enclosure.
	Isolation module: IP20
Dimensions	Indicator module – 53.50 mm × 97.85 mm (HØ × D), standard 30 mm Ø mounting hole
	Isolation module – 127.33 mm × 107.38 mm × 38 mm (HØ × W × D)
Battery	Industrial 4.0 V Lithium-ion (approx. ~ 750 tests).

Units = Inches (mm)

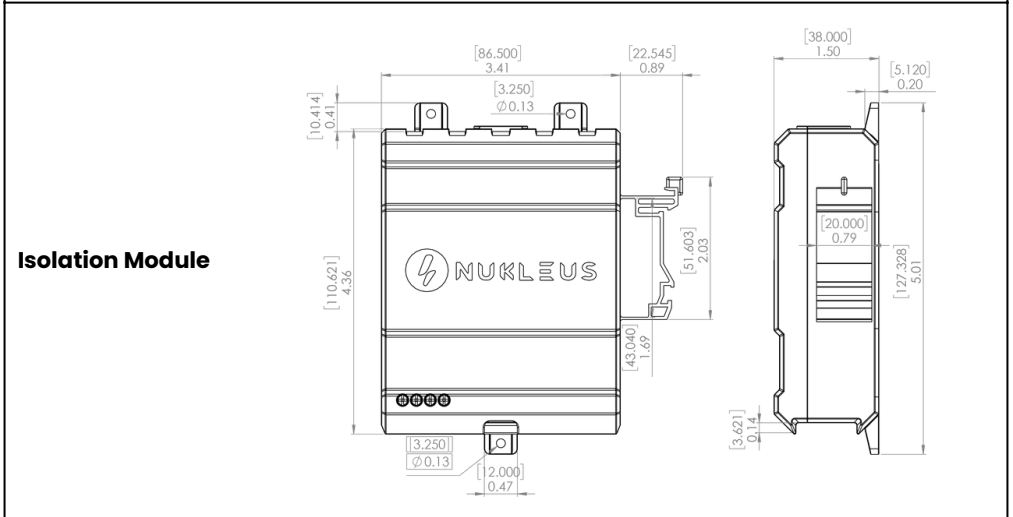
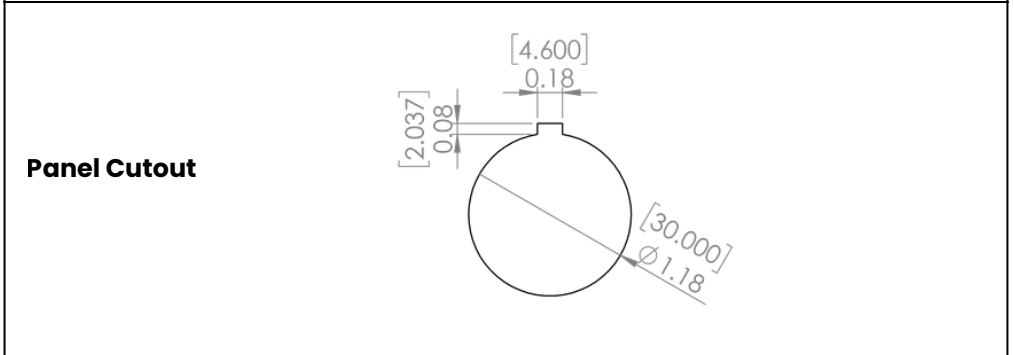
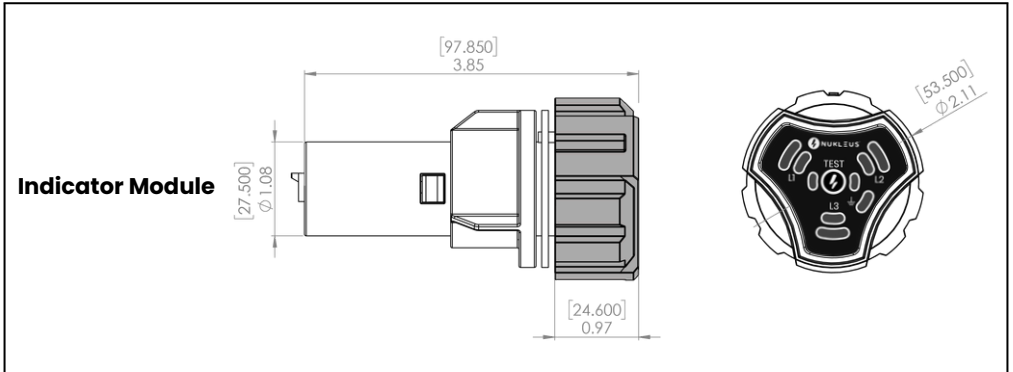

User interface label (to be fixed next to the product on the panel door)

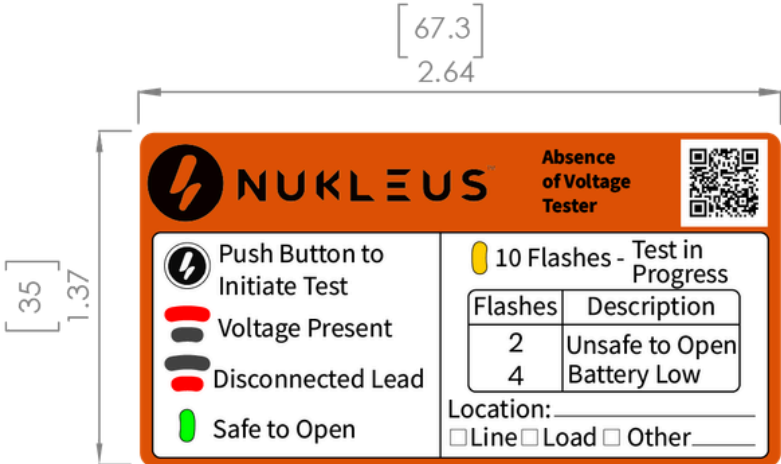

GENERAL INFORMATION

Prior to installing the AVT, verify and identify all electrical energy sources within the equipment. The AVT must be installed at the point in the circuit where voltage testing would normally be performed. It will only monitor for voltage at its installed location. No circuit components (such as circuit breakers, fuses, VFDs, switches, or other control devices) should be placed between any pair of sensor leads.

EFFECT ON SHORT CIRCUIT CURRENT RATING (SCCR)

AVT's certified to UL 1436 must function as a secondary circuit that is electrically isolated from the primary conductors by means of a transformer, optical isolator, limiting impedance, or equivalent method. This isolation is designed to minimize both electric shock and thermal hazards. These isolation circuits restrict current flow through the AVT to very minimal levels, if any.

The Nukleus AVT is rated for use on circuits up to 1000 VAC, with a maximum of 300,000 rms symmetrical amperes.

Sensor lead terminations for the AVT should be connected to the circuit conductor using suitable connectors, terminal strips, or power distribution blocks rated for the application. Wherever possible, use connection methods that do not pierce or otherwise compromise the integrity of the conductor. While connectors requiring conductors to be cut or spliced are acceptable, their use may reduce the overall SCCR.

USE OF OVERCURRENT PROTECTION

Installing an AVT with overcurrent protection is neither necessary nor advised. In accordance with UL 1436, AVTs are designed so that internal component failures do not subject the device to available short-circuit currents from the main power supply during normal operation or under single-fault conditions. The AVT employs high impedance to restrict both voltage and current flow through the device to safe levels. Furthermore, the AVT has been tested to withstand transient overvoltages up to 8 kV.

In some regions and countries, local compliance codes and regulations may require additional overcurrent protection. Multiple sensor leads must not be connected to a single overcurrent protection device. Sensor lead pairs must remain electrically isolated if the overcurrent protection device is in the open state. Overcurrent protection must not be applied to the two GREEN ground leads.

If the AVT sensor leads are 10 feet or less in length, they may be classified as feeder circuits and are exempt from overcurrent protection requirements [NFPA 70:2020 240.21(B)(1)(b) Exception and CSA C22.1:21 14-100(b)].

WARNING

The enclosure must be accessible only by means of a tool. For accurate indication of absence of voltage, the AVT must be installed and grounded in accordance with the instructions in this manual. Sensor leads must remain electrically independent and must not be mechanically connected to one another for the device to confirm proper circuit connection. After installation, verify correct device operation by following the Commissioning Checklist.

WARNING

Sensor leads with the same label designation must be terminated on the corresponding conductor (L1, L2, L3, GND). Each conductor shall have at least one dedicated sensor lead set, as illustrated in the schematic diagrams. Any excess length of sensor leads should be trimmed; splicing to extend lead wires is not permitted. When terminal blocks or power distribution blocks are used, the total length of sensor leads from the isolation module to the source conductors must not exceed 10 feet (3.0 m). All installations must comply with applicable local codes and standards. Safety and lockout/tagout procedures must always be observed when working on or near electrical equipment.

Prior to installation, confirm that power has been disconnected from the monitored circuit. The potential between each line and ground must measure less than 3 V, including any voltages originating from auxiliary systems.

ISOLATION MODULE

DIN-RAIL MOUNTING

Secure the isolation module by snapping it onto the DIN rail.

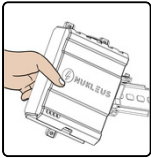

SURFACE MOUNTING

Mount the isolation module to a suitable surface using three #6 [M3.5] pan head screws or equivalent fasteners. For applications subject to high vibration, surface mounting with screws is the recommended method.

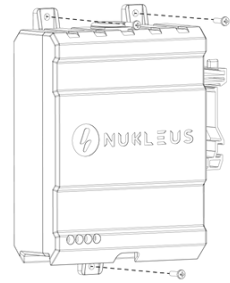

SENSOR LEAD TERMINATION

- Route the sensor and ground leads so that they are no longer than necessary, avoiding sharp edges, pinch points, or other sources of mechanical damage. While there is no restriction on the distance between the two leads of each phase, no circuit elements may be installed between them. Sensor leads must not be extended by splicing. When terminal blocks or power distribution blocks are used, the total lead length from the isolation module to the source conductors must not exceed 10 feet (3.0 m).
- Terminate the sensor and ground leads, using ferrules or terminals where possible. For proper AVT operation, sensor leads for each phase and ground must not be mechanically terminated at a common point. Sensor leads with the same label designation should be connected to the corresponding conductor (L1, L2, L3, GND). Each conductor must have at least one sensor lead set, as illustrated in the schematic diagrams. After termination, secure the sensor leads to the conductors and insulate all connections.

INDICATOR MODULE AND INSTRUCTION LABEL

Insert the indicator module onto the 30mm hole on the panel door and tighten the panel nut until both the nut and gasket are flush against the enclosure surface, then apply an additional 1/4 turn. Insert the battery into the battery tray with the positive terminal oriented toward the operator, ensuring the battery is fully seated before proceeding. Refer to the Battery Replacement section for additional details. Affix the instruction label to the exterior of the enclosure near the indicator module.

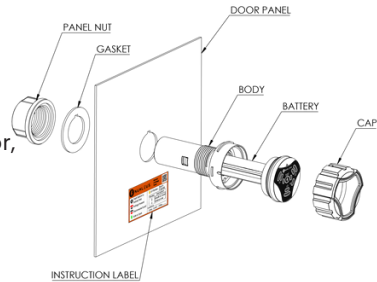

NOTE: The instruction label is UL-approved for use on galvanized steel, stainless steel, ABS, polycarbonate, and polyester-painted surfaces. For all other surface types, it is the installer's responsibility to confirm proper adhesion.

INTERCONNECT HARNESS CABLE

Insert one end of the interconnect harness cable into the back of the indicator module, pressing firmly until it latches. Pull back slightly on the connector to confirm it is securely engaged. Connect the other end of the interconnect harness cable to the isolation module port.

Maintain a minimum separation of 0.25 in. (6 mm) between the interconnect harness cable, the sensor leads, and other circuits inside the enclosure. The maximum allowable length for the interconnect harness cable connected to the INDICATOR port is 10 ft (3.04 m), while the AUX port allows up to 500 ft (152 m).

If the interconnect harness cable exits the enclosure containing the isolation module, it must be routed within conduit. When installed in conduit, the cable must be treated as a data cable and cannot share conduit space with electrical power conductors.

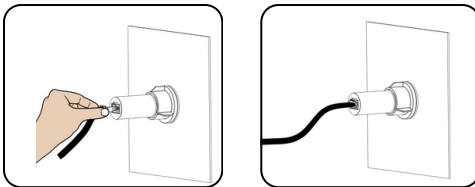

⚠ REPEAT THE COMMISSIONING CHECKLIST WHEN CHANGES TO THE ELECTRICAL SYSTEM ARE MADE.

Commissioning Checklist:

- De-energize the circuit to be monitored by the AVT.
- Perform a visual inspection of the AVT.

Interconnect Harness Cable

- Confirm the harness cable is fully latched at both the Indicator Module and the Isolation Module.

Indicator Module

- Verify O-rings and gaskets are correctly positioned.
- Check that the retaining nut is tightened securely.
- Confirm the battery is installed and is locked in place (if applicable).

Isolation Module

- Ensure the module is firmly mounted to the subpanel or DIN rail.

Sensor Leads

- Gently pull each sensor lead to verify secure termination.
- Confirm all terminations are fully insulated with no exposed wiring.
- Verify lead connections against the schematic wiring diagram. Each conductor must have two sensor leads of matching label designation, with no circuit elements between pairs.
- Ensure that sensor leads on each phase are not mechanically connected to one another.

Labels & Documentation

- Verify that an instruction label is affixed near each Indicator Module
- Record any changes in the panel documentation.

Final Steps

- Close the panel and secure all doors/covers.
- Press the test button to initiate the test. The AMBER caution indicator should flash rapidly, followed by the absence of voltage indicator illuminating GREEN.
- Review the Operating Instructions section of this manual before proceeding.

⚠ WARNING

Always follow your company's safety procedures when energizing equipment. To avoid electric shock, use proper personal protective equipment when working on or near electrical hazards.

Energize the system being monitored by the AVT.

Verify that the RED voltage presence indicators are illuminated.

Press the test button on the indicator module to initiate the absence of voltage test.

Look for the Amber caution indicator to flash repeatedly before turning to a solid indication. Refer to LED Indications section for more information.

You should not see the GREEN indicator illuminated when power is energized.

De-energize the circuit that is being monitored by the AVT.

Verify that voltage presence indicators are not illuminated.

Press the test button on the indicator module to initiate the absence of voltage test. Look for the Amber caution indicator to flash repeatedly before turning to a solid indication, followed by a solid GREEN illumination confirming absence of voltage.

WARNING

To prevent electric shock, always de-energize power before opening an electrical enclosure. Follow all applicable safety practices and lockout/tagout procedures when working on or near electrical equipment and use the appropriate personal protective equipment (PPE) when exposed to hazardous electrical energy. Installation and commissioning of the AVT must be performed by a qualified electrical worker who is familiar with both local and national electrical codes.

The AVT verifies absence of voltage only at the specific point in the circuit where it is installed. Other power sources within the equipment may still contain hazardous voltage. The absence of illuminated red voltage presence indicators does not confirm absence of voltage. Verification requires initiating the test sequence and observing GREEN illumination. The AVT must be operated exclusively by personnel trained in its use and knowledgeable of the requirements outlined in this manual. Operators must understand the device's function, the meaning of its indicators, and the limitations of the voltage presence indicators. They must also be aware of the AVT's installation location within the electrical system and of any additional electrical hazards not detectable by the AVT. Finally, operators must be capable of recognizing electrical hazards and adhering to lockout/tagout procedures.

Indicator Module Faceplate



- Pressing the test button initiates the test sequence. When absence of voltage is confirmed, the absence of voltage indicator illuminates GREEN. Refer to the Troubleshooting section for additional details.
- The voltage presence indicators illuminate RED when hazardous voltage is detected. However, the absence of RED indicators alone does not verify the absence of voltage. Refer to the LED indications section for additional details.

Voltage Presence Indications

1. When voltage is present on one or more phases, the corresponding voltage presence indicators will illuminate RED.
2. The absence of RED indicators alone does not confirm the absence of voltage. To verify absence of voltage, the test button must be pressed.
3. After the test is initiated, small RED LEDs illumination = Disconnected lead in corresponding phase, AMBER LED illumination = Not safe to open; GREEN LED illumination = Safe to open.

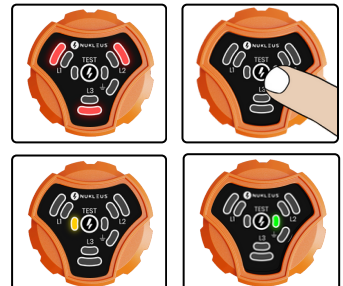

- De-energize the circuit following company safety procedures.
- Ensure lockout/tagout devices are applied to all relevant energy sources and verify that the voltage presence indicator LEDs are not illuminated.
- Press the test button to start the absence of voltage test.
- Observe the caution indicator AMBER illumination flashing followed by solid AMBER illumination from 1-2 seconds, which indicates the test is in progress.
- When absence of voltage is confirmed, the absence of voltage indicator will illuminate GREEN.
- If absence of voltage is not verified, the indicator will flash AMBER ten (10) times consecutively, then followed by certain number of AMBER illuminations, see the Troubleshooting section for the following details.

Below are the base scenarios before Pust-to-Test button is pressed (before the test is initiated) :

Condition	LED Indication
Voltage Presence	When voltage is present, larger LED illuminates in the respective phase to indicate voltage presence.
Disconnected Lead	If any of the phase lead is disconnected, the corresponding small LED illuminates.
	Likewise, when the Ground (GND) lead is disconnected, the GND LED illuminates.



- Here, L1-L2-L3 LED illuminates all three phases are live.



- Here, L2 lead is disconnected, small L2 LED illuminates.



- Here, Neutral lead is disconnected, small GND LED illuminates.

When Pust-to-Test button is pressed (the test is initiated) , the test progress is indicated by a fast-flashing AMBER LED followed by solid AMBER illumination from 1-2 seconds, followed by the following LED indications to indicate the system status:

Device Status	LED Indication
Battery Health	Four AMBER flashes = weak battery; replace the battery.
Unsafe-to-Open	Two AMBER flashes (when voltage is present)
	small RED LED flashes 3 times (indicating disconnected lead)
	No LED illumination
Safe-to-Open	GREEN LED (applies only - leads are connected correctly, battery is healthy).



UNSAFE TO OPEN

SAFE TO OPEN

WARNING

- Always de-energize power before accessing any electrical enclosure.
- Follow all safety and lockout/tagout procedures when working on or near electrical systems and equipment.
- Use appropriate personal protective equipment (PPE) when working around sources of hazardous electrical energy.

Servicing and Replacement Parts

- Only the battery, interconnect harness cable, O-rings, and gaskets are serviceable. No other components of the product may be repaired or replaced.
- Do not attempt to open the indicator module or isolation module for repair or modification. Use only specified replacement parts when servicing the product.
- Only use AVT system components (interconnect harness cable, isolation module, indicator module). Standard Ethernet cables or other components must not be used.

Indicator Behavior During Testing

- After pressing the button, the AMBER LED flashes 10 short pulses, followed by a solid AMBER indication for 1–2 seconds. It then displays a flash sequence that indicates why absence of voltage was not verified (refer to the table below).

Number of Flashes	LED	Description	Recommended Actions
2	AMBER LED	Voltage detected above the threshold	 WARNING: This indicates that the enclosure is energized. Follow the safety procedures and use the appropriate PPE when investigating. If the panel has a stored energy source, wait several minutes then re-test.
3	Small RED LED	Disconnected lead of respective lines	Check the wirings to make sure all the leads are connected properly.
4	AMBER LED	Low Battery Health status	Replace the battery and re-test.

Troubleshooting: Caution Indicator Does Not Illuminate After Pressing Test Button

1. System Cable

- Confirm that the interconnect harness cable is fully seated in the connectors on both the indicator module and isolation module.
- The indicator module will not function if it is not properly connected to the isolation module.

2. Power – AVT Battery

- Ensure the battery tray is fully inserted into the indicator module housing with the cap installed.
- The indicator module will not operate effectively with a low battery.



If any issues arise during installation, operation, or maintenance of the Nukleus AVT, contact Nukleus Technical Support for assistance.

WARNING

The battery-powered indicator module contains a lithium battery, which presents fire, explosion, and severe burn hazards. Do not crush, recharge, disassemble, incinerate, expose to heat above 85 Deg and water. The AVT is not compatible with standard 1.5 V AA alkaline batteries; use only Nukleus-approved batteries. Do not attempt to open the indicator or isolation modules for repair or modification. In critical sealing applications, such as washdown environments, replacement of O-rings and gaskets is recommended every five years.

VISUAL INSPECTION

Periodically inspect the AVT and replace any damaged components, cables, or terminations.

- Sensor Leads: Verify that terminations are tight, the leads are secure and show no signs of damage.
- Interconnect Harness Cable: Confirm the cable is fully latched at both ends, secure, and free of damage.
- Indicator Module: Check that O-rings and gaskets are not dry or brittle. Ensure the retention nut is tightened and the battery cap is firmly in place.





CLEANING INSTRUCTIONS

The indicator module may be cleaned using a damp cloth or an isopropyl alcohol-based cleaner. Do not use abrasive materials or strongly alkaline cleaners. Cleaners should not remain on the device for an extended period and should be rinsed immediately. Avoid applying cleaners in direct sunlight or at elevated temperatures. Before performing any operation, verify that the O-rings and gaskets are in good condition, undamaged.

BATTERY REPLACEMENT

Follow the steps in the next page to replace the battery. The table below provides information regarding the battery used in AVT.

Nukleus Part No.	Manufacturer	Mfr. Model No.	Size	Description	Operating Temperature
AVT-BATTERY	Tadiran	TLM-1550	ER14505	4.0 Volt Lithium Battery	-40°C to +85°C (-40°F to 185°F)

<p>1. Rotate the indicator module cap approximately 90° counterclockwise until it reaches a stop.</p> 	<p>2. Hold the battery tray and slide it outward until it reaches the built-in stop. The tray is not designed to be fully removed.</p> 	<p>3. Remove the used battery and insert a new one. Ensure the battery is fully seated before proceeding.</p> 	<p>4. Slide the battery tray back into the housing. Insertion and connection of the battery will automatically initiate a test of the AVT.</p> 	<p>5. Reinstall the cap with the help of provided indicators and rotate it clockwise until it locks securely in place.</p> 
--	--	---	--	---

O-RING AND GASKET REPLACEMENT

O-rings and gaskets may be replaced if they become dry or brittle. In critical sealing applications, replacement is recommended every five years.

INDICATOR MODULE

O-Ring and Gasket Replacement

To replace O-rings and gaskets, order the approved NUKLEUS AVT replacement parts. Follow these steps:

1. Disconnect the interconnect harness cable and remove the panel nut.
2. Replace the gasket and O-rings.

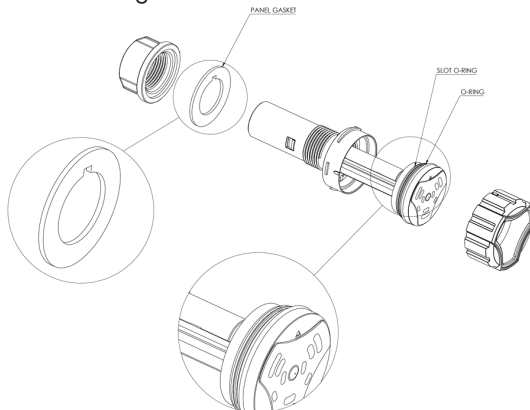

5-YEAR LIMITED WARRANTY

1. Warranty Coverage

Nukleus guarantees that its products will function as described and will be free from manufacturing defects for 4 years from the date of invoice from Nukleus (or) the authorized distributor, but not to exceed 5 years from the date of shipment from the factory whichever is earlier.

This warranty applies only when the product is installed and operated strictly in accordance with the Nukleus User Manual.

2. Firmware Coverage

Any firmware included with a Nukleus product is covered under the same 5-year warranty period, provided the product is installed and used correctly with reference to the user manual.

Nukleus does not guarantee that the firmware will run without interruptions or meet every user's specific requirement.

3. Replacement Promise

If a Nukleus product is found to have a confirmed manufacturing defect covered under this warranty, Nukleus will replace the product with the same model or an equivalent model. No repairs will be performed.

Nukleus may request that the defective unit be returned for inspection through the RMA (Return Material Authorization) process.

The replacement unit will be covered for the remaining duration of the original warranty period.

4. Third-Party Items Not Covered

This warranty does not apply to:

- Products or accessories manufactured by other brands
- Third-party software or firmware
- Any item not manufactured or supplied by Nukleus

All concerns related to such third-party items must be addressed directly with their respective manufacturers.

5. What Is Not Covered & Liability Limits

This warranty does not cover damage to the equipment, property, and any injuries to the personnel resulting from:

- Incorrect installation, wiring errors, or unsafe electrical practices
- Tampering, opening, modifying, or repairing by anyone not authorised by Nukleus
- Failure to follow the User Manual, installation instructions, or safety guidelines prescribed under the local and federal codes along with safe electrical work practices.
- Unsafe work methods, including bypassing safety features, incorrect testing procedures, or skipping LOTO requirements as outlined in NFPA 70E, Article 120.6.
- Rough handling, physical impact, or misuse of the product.
- Operating the product outside its rated electrical limits, environmental conditions and technical specifications.
- Unapproved physical hardware and firmware modifications or use of any external software.

Nukleus products are not designed, tested, or certified for use in medical equipment, life-support systems, emergency response devices, or any application where a product failure could directly impact personal safety or cause serious harm.

Customers are fully responsible for ensuring that Nukleus products are not deployed in high-risk environments where uninterrupted operation is essential to protect human life or mitigate hazardous conditions.

Nukleus is not responsible for any indirect or consequential losses, including:

- Loss of data
- Loss of revenue or profits
- Business downtime
- Any special, incidental, or consequential damages

Nukleus' liability is strictly limited to replacement of the defective product.

6. General Terms

This warranty applies only to genuine Nukleus products purchased from authorised partners. No dealer, installer, or employee is permitted to modify or extend this warranty.

Use of Nukleus products with modified systems or unapproved third-party equipment is done entirely at the user's own risk.