



AlcovePro 4k Cine Professional Action Camera User Guide



GET THE APP

“YUTUPRO”



(see the Operation
Section 12 on how
to setup Wifi)

www.alcovepro.com

1 Orchard Beach Blvd.

Port Washington, NY 11050 USA

info@alcovepro.com

Introduction

The AlcovePro 4k Cine Sport/AlcovePro 4k Cine is a highly advanced Professional/Prosumer true 4k (3840x2160) UHD (Ultra High Definition) digital motion video camera with an exceptional Sony true 12MP image sensor. It is packed with powerful, useful and fun features that let the average photographer attain great results. Best of all, it has a HUGE, easy to use touch screen display that spans virtually the entire back of the camera to access all those cool Pro features with super simple controls so you can quickly and easily take advantage of them. None of that fumbling with multiple, multi-function buttons to remember. The 4k Cine is built for digital video recording, still photo shooting, audio recording, underwater recording and is designed for action environments, including vehicle recording, outdoor sports, home security, and even underwater sports/diving.

Product Features

- 2.45" HUGE LCD TOUCH SCREEN, fast, easy to operate and view. No confusing multi-function buttons to remember how to operate.
- Amazingly small - 2.5" x 1.7" x 0.85", 3.1 ounces

- 6 degrees-of-freedom electronic image stabilization to record smooth and high-quality action shots
- 170° wide angle (narrow/middle/wide), 7-element optical glass lens
- Waterproof to 90 ft with included case, record the amazing underwater world!
- Five video resolutions: support for 4K@30fps / 2.7K@30fps / 2k@60fps / 1080P@120fps / 720P@240fps
- Support for both 4:3 and 16:9 aspect ratios
- UltraSlo™ highspeed, ultra-slow-motion capture
- User adjustable time lapse modes, for cool photo and video effects
- HDR10 (High Dynamic Range) for amazing image reality
- Built-in Wi-Fi for easy uploads and remote control of the camera
- Multiple internal microphones for optimal sound capture

- External wired microphone option for superior sound capture
- Remote control smartphone app, easy to control and use
- Internal, removable/replaceable 1000mAh battery, to enable extended shoot time
- Optional physical remote
- Multiple shooting modes and video recording modes; Video, Photo, Time-lapse, Slow motion, Photo-lapse, Sequence, Video+Photo, Car mode, Underwater mode.
- USB-C high-speed transfer connector
- Industry leading HISILICON Hi3559 CPU chipset, highly advanced performance, for a stable recording experience
- World class 12MP Sony IM377 image sensor
- TF/MicroSD standard image card to 64G (not included)

Camera Illustration

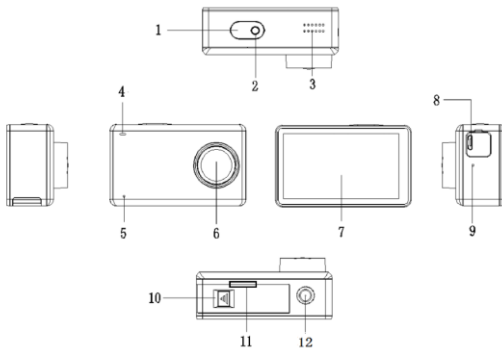

1. Shutter - ON (1 sec) / OFF (sec 3)
2. Video Indicator light (blinking indicates video recording is in progress)
3. Speaker

4. Working/Charging Indicator light:
 - A. Solid Red: the camera is charging.
 - B. Blinking Blue alone: the camera WIFI is ready to connect.
 - C. Solid Blue: WIFI connected.
 - D. Blinking Blue in conjunction with Video Indicator 2: recording video
5. Microphone #1
6. Camera lens
7. Touch Screen
8. USB-C standard connector
9. Microphone #2
10. Battery and Micro SD Card access panel (press and slide in the direction of the arrow to open)
11. Micro SD Card slot (need to open the battery compartment to access)
12. Standard camera screw mount for tripod integral to the camera – not a ‘clip on’ option

Waterproof case

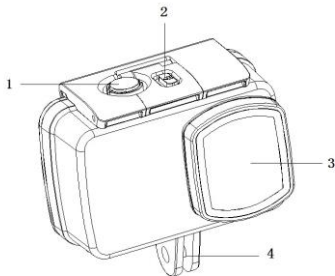



1. Shutter/ON/OFF
2. Case security lock (grab and pull upward on the upper front edge of case security lock clasp to release back panel of the waterproof case)
3. Camera/lens
4. Mounting bracket

IMPORTANT !

READ BEFORE YOU BUY A Micro SD CARD!

The AlcovePro 4k Cine is a true 4k camera and as such needs fast micro SD cards to work correctly. For video, the camera is certified to work with **U1 or U3 cards**.

4k/UHD: If you are shooting 4k/UHD you need a U3
card. 

HD/1080p: If you are shooting HD or lower, a U1 card
is fine. 

Anything less may work depending on your usage, but it is not certified to work, buy at your own risk.

Operation

1. Installing Micro SD Card

- A. On the bottom of the camera, slide the door for the battery cover in the direction as indicated on the cover  and then open the battery cover, exposing the SD card slot. Insert the SD card as shown, ensuring that the card is 'clicked' into place – the card will be barely visible. If you can see ~1/8th of an inch of the card sticking out, you have NOT yet clicked it into place – press down again –with the nail of a finger and hear the click.

In order to remove the card, press down on the card slightly – with a finger nail, until you hear a click, then carefully release and the card will be ejected from the slot. CAUTION! The card is ejected forcefully and if you are not careful it will FLY across the room!

- B. The AlcovePro 4k Cine is a true 4k camera and as such needs fast micro SD cards to work correctly. For video the camera is certified to work with **U1 or U3 cards.4k/UHD:** If you are shooting 4k/UHD you need a U3 card. **HD/1080p:** If you are shooting HD or lower, a U1 card is fine. Anything less may work depending on your usage, but it is not certified to work, buy at your own risk.

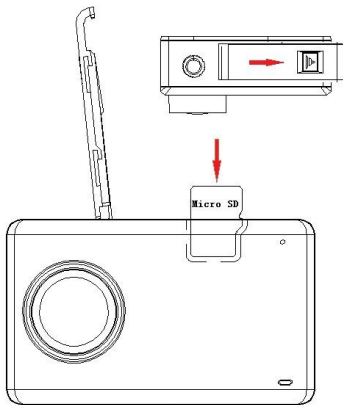

2. Installing and removing the battery

- A. On the bottom of the camera, slide the door for the battery cover in the direction as indicated on the cover and then, open the battery cover, exposing the battery slot.
- B. Insert battery as shown – it only fits in one direction.

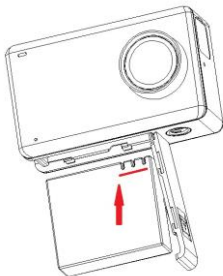

3. Charging

- A. You can recharge the AlcovePro 4k Cine by connecting it directly to a computer or with the supplied USB power adapter.









- B. AlcovePro 4k Cine can record video and images while charging.
- C. Camera can be charged even when the power is switched off. The camera will get warm while charging and during use – this is normal.
- D. While connected to a charging device, the camera indicator light (4) will be red.
- E. You can also charge the batteries with the optional external battery charging cradle.

4. Switching the camera on and off

- A. Press and hold the ON/OFF switch for 1 second to turn it ON.
- B. Press and hold the ON/OFF switch for 3 seconds to turn it OFF.
- C. CAUTION: The camera does not turn itself off automatically.

5. Shooting Mode Selection

A. Start camera, touch the bottom of the screen to access the 9 shooting modes (6 modes will be displayed at one time – scroll up/down). Shooting modes can be selected by sliding the menu up or down to reveal all 9 and then clicking on a specific icon.

 Normal Video	 Video Lapse	 Slow Rec
 Normal Photo	 Photo Lapse	 Burst Mode
 Car Mode	 Timer Photo	 Video+Photo

Modes

- a. **Normal Video** – with current video setting and options
- b. **Video Lapse** – time-lapse video
- c. **Slow Rec** – UltraSlo slow motion video recording
- d. **Normal Photo** – with current photo setting and options
- e. **Photo Lapse** – time lapse photos
- f. **Burst Mode** – rapidly capture multiple photos
- g. **Car Mode** – record a continuous loop into the SD memory
- h. **Timer Photo** – delayed timer photo
- i. **Video+Photo** – while recording video capture still images on a set time interval

Note: If you want **Underwater Mode**, see Section 6, D), l), iv).

6. Menu Settings and Advanced Professional Controls

1. Select the Shooting Mode, then click on the lower right corner of the

screen settings icon  to enter the Menu Settings. These settings are context sensitive. If you are shooting in Video Modes you get a set of video options, if you are in Photo Modes you get a set of photo options: For example, if you are in Photo Lapse mode you will see an additional menu to control the time lapse setting in the sub-menus.

Context specific mode options have “>>>>>>>” in front of them.



2. Video mode options

a. Resolution and frame rates

- i. >>>>>>> 4K(3840x2160) / 30fps (UHD 16:9)
- ii. >>>>>>> 4K(2880x2160) / 30fps (4:3)
- iii. >>>>>>> 2.7K(2704x1520) / 30fps (16:9)
- iv. >>>>>>> 2.7K(2704x2028) / 30fps (4:3)
- v. >>>>>>> 1440(2560x1440) / 60fps (16:9)
- vi. >>>>>>> 1440(2560x1440) / 30fps (16:9)
- vii. >>>>>>> 1440(1920x1440) / 60fps (4:3)
- viii. >>>>>>> 1440(1920x1440) / 30fps (4:3)
- ix. >>>>>>> 1080(1920x1080) / 120fps (HD 16:9) UltraSlo™ slow motion
- x. >>>>>>> 1080(1920x1080) / 60fps (HD 16:9)
- xi. >>>>>>> 1080(1920x1080) / 30fps (HD 16:9)
- xii. >>>>>>> 1080(1440x1080) / 120fps (4:3) UltraSlo™ slow motion
- xiii. >>>>>>> 1080(1440x1080) / 60fps (4:3)
- xiv. >>>>>>> 1080(1440x1080) / 30fps (4:3)
- xv. >>>>>>> 720(1280x720) / 240fps (16:9) UltraSlo™ slow motion
- xvi. >>>>>>> 720(1280x720) / 120fps (16:9) UltraSlo™ slow motion
- xvii. >>>>>>> 720(1280x720) / 60fps (16:9)
- xviii. >>>>>>> 720(1280x720) / 30fps (16:9)

- b. Video Segmentation – set a fixed capture time for video segments
3min/5min/10min/15min/OFF
- c. >>>>>SlowRec - sets 1280x720 and 240 fps for UltraSlo™ slow-motion
- d. >>>>>Automobile - Looping time options: 3/5/10/15min before you start recording over the stored video
- e. >>>>>Automobile - Boot Recording on/off – automatically start recording at power on/boot up
- f. >>>>>Video+Photo – will capture a photo at set intervals while also taking a video. Time lapse interval of 3/5/10/30/60 seconds
- g. FOV – Field of View – Wide/Normal/Narrow
- h. Record mode – for audio – On/Off
- i. Encode Mode – Video compression CODEC - H.264 / H.265 – until or unless you know what you are doing, only use H.264 – see the note at the end of this doc on H.265.

- j. Image Stabilization – This is a fantastic implementation of 6 axis image stabilization – give it a try – you will really enjoy the results!
- k. Meter Mode – professional control for the weighting of the meter areas
 - 1. Center
 - 2. Average
 - 3. Spot
- l. AWB – Auto White Balance – Auto, Daylight, Cloudy, Tungsten, Flour_L, Flour_H
- m. ISO – Auto as well as 100, 200, 400, 800, 1600 ASA
- n. Exposure - EV settings: -2 through +2 EVs

3. Photo mode options



Select a photo shooting mode, then click on the lower right corner of the screen settings icon  you can enter the photo menu settings:

Context-specific mode options have “>>>>>” in front of them.

a. Resolution for still images:

- i. 16MP – 4608 x 3456
- ii. 14MP – 4320 x 3240
- iii. 12MP – 4000 x 3000 – native resolution of the awesome Sony sensor
- iv. 8MP – 3840 x 2160
- v. 5MP – 2560 x 1920
- vi. 3MP - 2048 x 1536

b. >>>>>PhotoLapse - TimeLapse 3sec, 5sec, 10sec, 30sec, 60sec intervals

c. >>>>>BurstMode - Burst Number 3/5/10/15 photos taken on one shuttle click

- d. >>>>>TimerPhoto - Self timer 1sec, 3sec, 5sec,10sec
- e. Exposure +/- EV settings: -2 through +2
- f. ISO – Auto as well as 100, 200, 400, 800, 1600 ASA
 - g. Auto White Balance (AWB) – Auto, Daylight, Cloudy, Tungsten, Flour_L, Flour_H
- h. Metering modes: Center, Average, Spot
- i. HDR (High Dynamic Range) On/Off (see Special Notes below)

D. Additionally, for the  icon, you can set:

- a. Auto Dormant (shut off the screen, delay) Off (never)/1min/3min/5min – CAUTION: the camera is not off, just the screen, it is still consuming power.
- b. Start Action – select what mode the camera runs when it is started
- c. WIFI – the basic setup for WIFI – (but NOT where you turn it on – to turn on you need to quickly swipe down the main display when in photo/video mode and click on the WIFI  symbol – see #11 Shortcut Screen Mode below)
- d. Factory Reset

- e. Format the SD card
- f. Language
- g. Time/Date setup
- h. Date Stamp – On/Off
- i. LDC – Lens Distortion Correction – With a 170° super wide-angle lens there is a natural bit of distortion (curvature/bending/fisheye). The camera can automatically reduce that distortion with the onboard CPU of the camera, at the time of picture taking. The setting is Off/On. Try it out first to see if you like it.
- j. Inversion Mode – flips the display upside down
- k. Frequency – 50Hz or 60Hz – set to your home country – USA is 60Hz.
- l. Scene – Scene setting will adjust the various parameters of the camera to optimize them for the particular type of scene.
 - i. Auto
 - ii. Personage – for People
 - iii. Scenery

iv. Underwater -



v. Defog – for foggy/misty settings

- m. WDR – Wide Dynamic Range – this setting is designed to improve the photo quality in settings that have large degrees of contrast and shadow detail.
- n. Key tone – turn off the touch beep
- o. Information – info about the firmware build number and OS number

7. Photo Shooting Mode

A. In the shooting mode, select the photo mode, press the shutter button to take pictures.

8. Video Recording Mode

A. Choose the video mode in shooting mode, press the shutter button for recording, press the shutter button again, to stop the video.

B. Video Indicator 2 and Indicator 4 will be flash when a video is being recorded.

9. Playback Mode

A. In the bottom left corner of the screen, click on the replay icon , to enter the playback mode. In playback mode you can easily touch the < or > to index to the clips/photos to review, playback or delete photos and video.

10. Image and Video data storage and transfer to PC/Mac

A. Using the Micro USB data cable, the data files can be copied to a computer, smartphone or tablet device to for viewing and playback. You can also remove the Micro SD card and use a card reader to read the image data into a PC.

11. **Shortcut Screen Mode**

- A. Start camera, touch the top edge of the display and **QUICKLY** slide your finger down the face of the screen, to display the Shortcut Screen Menu. If it doesn't display you are not swiping fast enough.

			
WIFI on/off	Remote Control on/off	Screen Lock on/off	Shutdown

12. **Setting up the WIFI connection from the camera to your Smartphone or tablet**

REMEMBER, you are setting up the camera to connect directly to your phone, **NOT** to your home network or through your home network.

- A. Install onto a smartphone or tablet the application software called **YUTUPRO**. For Android systems simply search on Google Play

and download, for Apple's IOS systems the app can be downloaded from the Apple App Store.



B. Alternatively, you can scan the QR codes below to install:

Apple QR code below:



Android QR code below:



C. Start the camera, click the settings icon  in the bottom right corner of the display. Then in the menu displayed, click the newly displayed settings icon  and then select the WIFI menu item. The camera screen will display three WIFI menu choices:

- WIFI Information
- WIFI Password – default is “12345678”
- WIFI SSID – default is 4KSport_XXXXX

The default SSID is “4KSport_XXXXX” (the “XXXXX” part varies from camera to camera), **the default password is “12345678”** both of which can be changed in these menus. You have now set up the WIFI, but the camera WIFI it is NOT TURNED ON YET.

D. ALERT! You must turn the WIFI for the camera ON! To do this you need to access the Shortcut Screen Mode. Go to the main camera display (just like when you turn it on) and QUICKLY swipe down from the top of the display towards the bottom to expose a menu with the WIFI icon  (and the remote control, screen lock and shutdown icons). Slowly will not work. Quick!

E. On your phone or tablet device open the WIFI menu for that device

(Android: Settings/Wireless and Network/WLAN, Apple: Settings/Wifi/Wifi_Network) - where you have the list of WIFI connections the smartphone or tablet device can connect to. In these settings, search for and connect to “4K Sport_XXXX” using the **default password: 12345678**. After the connection is successful, the camera screen will display “WIFI connection ready”.

F. After the success of the connection, and from the smartphone or tablet, open the App "YUTUPRO" and select your specific device (unless you have several AlcovePro Cine 4k cameras all set to the same SSID it will be the only device displayed).

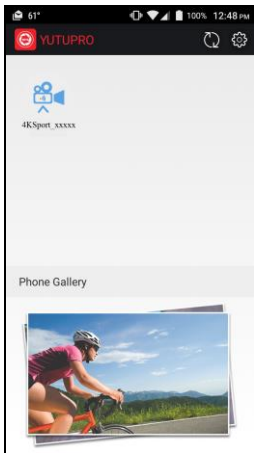

Android

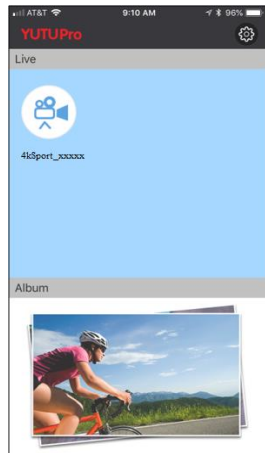





Apple

G. From the YUTUPRO app you can do a number of things:

1. Control all of the settings of the camera
2. Start and stop recording or taking of photos
3. Send your videos and images to any app on the phone to email or text or chat– VERY COOL!
4. See a live feed from the camera (nice!)
5. See all the videos and still images on the camera
6. View and playback those images and videos
7. Delete videos and photos
8. Change most significant settings for video and photos

H. The Remote Control (optional but fun to have)

1. If you are lucky and have the remote-control wristband, the operation is pretty simple.
2. On the Camera, turn the remote ON in the Short Cut Mode (swipe down QUICKLY) and then click on the Remote Icon.

			
WIFI on/off	Remote Control on/off	Screen Lock on/off	Shutdown

Be aware that the Remote Control setting on the camera will always be OFF when you start the camera – we want to conserve battery power.

3. With the Remote Control you can:
 - A. Turn the touchscreen display off or on (left button)
 - B. Take a picture (right TOP button)
 - C. Start and stop a video recording (right BOTTOM button)

It's really easy, simple and right on your wrist, no fumbling with a separate remote to get a great selfie!

RECHARGING the REMOTE: the remote is rechargeable – no batteries to mess with. On the back is a little cover and under there is a regular USB/phone charger connection.

Special Notes on using the AlcovePro 4k Cine

Please visit <http://www.alcovepro.com/support> for a full list of FAQs and tips and tricks. But here are a few suggestions to keep you out of the weeds.

Warm Camera – the camera gets warm when being used and when charging. That is normal. It is a tiny package with a bunch of electronics (even your smartphone gets warm when using for a long time or charging). BUT, be careful about leaving the unit in direct sun for a long time, especially in the underwater case. Warm becomes hot in direct sun, and hot is not a good thing nice electronic devices.

HDMI Output – The camera allows for the playback of video and still images through the HDMI output connector. The output of this HDMI is at 1027x576 resolution. If you shot the video at 4k/UHD/HD it will be downsampled to that resolution for output. Also, the camera does not support a live feed of the video signal from the HDMI port, it is only for playback of previously stored videos on the camera.

Using H.265 video compression CODEC option: H.265 is a great new compression CODEC which can save 50% in storage and supports live streaming BUT it is still early in market adoption and playback on PCs is

not trivial. Unless you are a professional and have a solid H.265 workflow to process the files (and to deliver them so they playback in a format for your target audience) we **STRONGLY** recommend you not use it for everyday video sharing.

Using HDR option: HDR (High Dynamic Range) is a great up and coming imaging technique for video and photography where image files are expanded to add more ‘bits’ to the color/grey scale. The images have greater depth, nicer shadow detail and smoother contours. But like with most new tech the adoptions early versions take time. On the 4k Cine we support 10bit HDR10 and in this version the camera CPU needs to do a significant level of processing to store the HDR image. It is not unusual to see a delay in writing the image to the SD - i.e. “Processing.....” after an image is taken of ~6+ seconds. So be forewarned. We know that is a drag and we are beating our engineers to make it better on our next camera (they did their best on the 4k Cine!)

Formatting SD cards – 64 Gb and 128 Gb: The AlcovePro 4k Cine supports 64GB and 128GB cards, **HOWEVER**, those cards must be formatted to FAT32 format before you put them in the camera. Most manufacturers format 64GB and 128GB cards with EXFAT, which out of the box will not work in the camera.

Your Windows PC can be used to format the cards to FAT32, BUT you need to use a product like DiskGenius <https://www.diskgenius.com/> to re-format the card to FAT32. The software built-in to your PC will not do it. For the MAC you can use their Disk Utility app - <https://www.youtube.com/watch?v=NJCczfVXQDc>

Formatting SD cards and size problems: If you did not buy a brand-new SD card and decided to use one from another device, be aware that sometimes the card can get formatted into non-standard camera formats – formats for other devices that neither the camera nor your PC will recognize. Symptoms include the card showing a much smaller capacity than its rated size. Unfortunately, your Windows PC can't undo the temporary damage – it is blind to the non-Windows format of the card. The easy answer is to just go buy another card, but your next best bet is to find a good computer friend who likes Linux/Unix. Ask them to use the Linux software called “GParted” to remove all the partitions on the card (WARNING: all your data will be lost! So save it off) and reformat back to its original size, using the FAT32 format (they will know what you are asking if you show them this paragraph). You can also try the software - DiskGenius <https://www.diskgenius.com/>

Device Care

1. Take care of the lens! It sticks out slightly from the front of the camera (so it can capture those amazing 170° shots!) but that also means placing the camera face down risks scratching the nice optical glass. Also, use the included lens cloth to clean it – regular tissues will scratch the glass!
2. Use the included lens cap to protect the lens when not in use.
3. Keep it safe from falling and dropping.
4. Keep it a safe distance from any strong magnetic interference from large electrical machinery which might affect the sound or image quality.
5. Don't expose the camera to high temperatures and strong sunlight for extended periods.
6. Use high-quality, Class 10 Micro SD Card for the best results, 64Gb or less.
7. Don't place your Micro SD Card near strong magnetic objects to avoid data error.

8. The camera will feel warm to the touch while in use or during charging. If the device gets overly warm unplug it immediately from the power outlet to prevent a fire hazard.
9. Keep it away from children while charging.
10. Store the device in a cool, dry and dust free local.
11. Take care when using in direct sunlight – all electronics are sensitive to too much heat.

Specifications

CPU	Hisilicon Hi3559
Sensor	Sony IMX 377
Lens	170° A+ 7 element glass wide angle
Screen	2.45-inch LCD touch screen
Video/Compression format	MP4/H.264 & H.265
Video resolution	4k (3840*2160) 30FPS 2K (2560*1440) 60FPS 1080P (1920*1080) 120/60FPS 720P (1280*720) 240/120/60FPS VGA (640*480) 240FPS
Picture format	JPG
Picture resolution	16M/14M/12M/10M/8M/5M/3M/2M
Visual angle	Standard / wide / narrow angle
Storage format	Micro SD card, maximum support 64G
USB	USB-C connector
Waterproof depth	90ft
Audio frequency	Stereo
Battery	3.7V/1000mAh
Typical Battery life	85 Minutes
Measurement	2.5" x 1.7" x 0.85"
Weight	3.1 ounces
Video modes	Video/Time-lapse/Slow motion
Photo modes	Photo/ Photo lapse/Sequence/Video+Photo
PC Operating systems	Windows XP /Mac OS
Languages	English/French/German/Spanish/Italian/ Portuguese/Simple Chinese/Japanese/Traditional Chinese/Russian

Specifications subject to change without notice. All rights reserved.
UltraSlo is a trademark of AlcovePro. Google App and Apple App Store logos are
trademarks of Google and Apple respectively