

**DELCO DRAINS**™

YOUR HYGIENIC  
DRAIN SOURCE SOLUTION





CFIA COMPLIANT



QUALITY APPROVAL

DELIC

# SLOT DRAINS

INTERNALLY SLOPED CAST-IN-PLACE STAINLESS STEEL SLOT DRAIN SYSTEMS DESIGNED TO ACCOMMODATE ALL OF YOUR DRAINAGE NEEDS

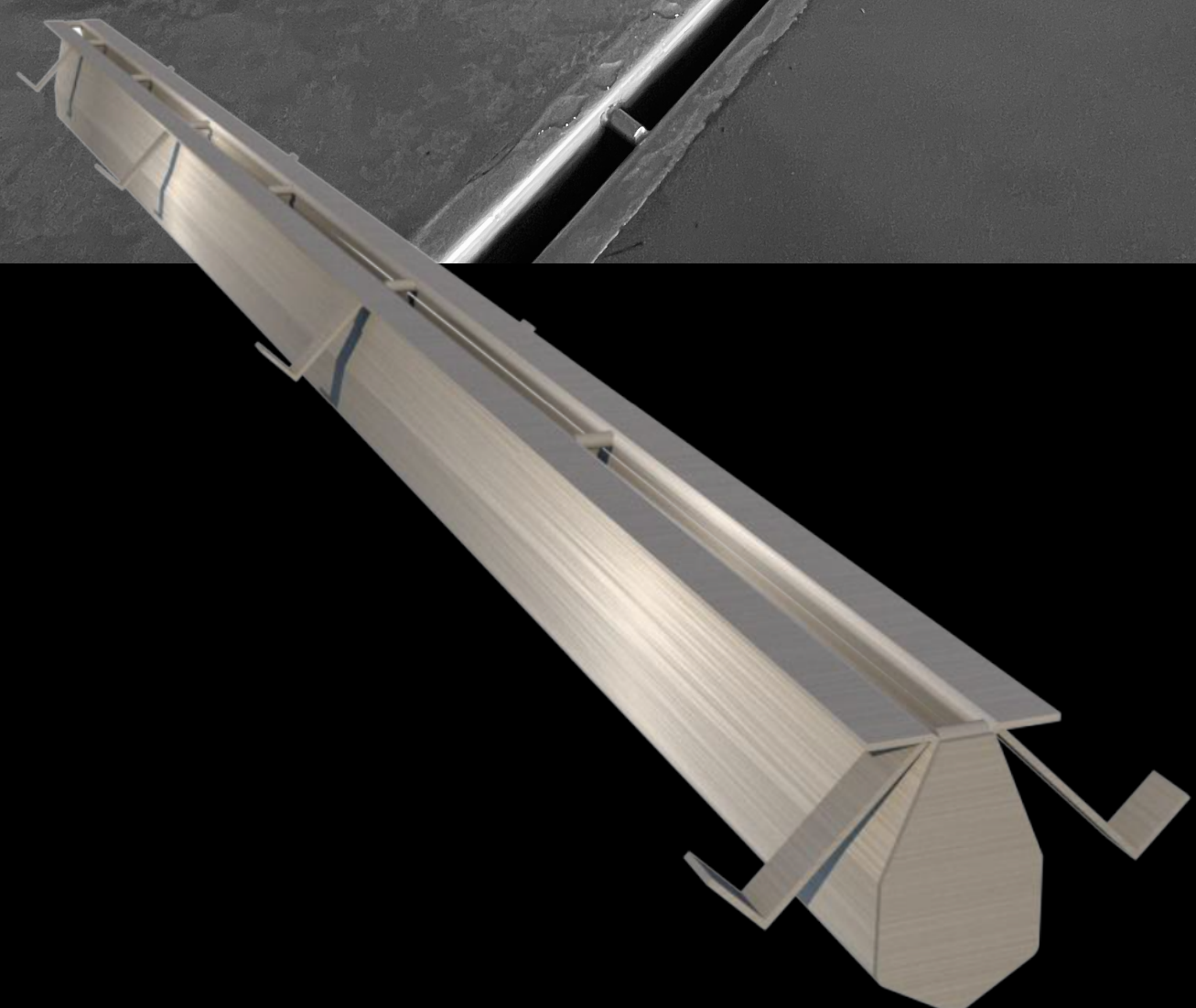

# DELC SLOT DRAINS

## CUSTOM

Engineered to fit any location in length, depth or configuration

## STAINLESS STEEL

304 or 316L Stainless Steel constructed for extreme durability and low maintenance.

## DESIGNED

Fully welded design, smooth inside finish to eliminate any build up of bacteria or debris and ease of sanitation

## CFIA COMPLIANT

Compliant design: 7/8" slot width, 1" per 6ft slope (alternate slot width and/or slope available). Internal surfaces can be visually inspected.

## MATERIAL HANDLING

Suitable for all foods, beverages, water, oils and mild acids, as well as slurry's in the pulp and paper industry

## DURABLE

No bending of grating by heavy traffic, thereby eliminating tripping hazard and malfunctions.

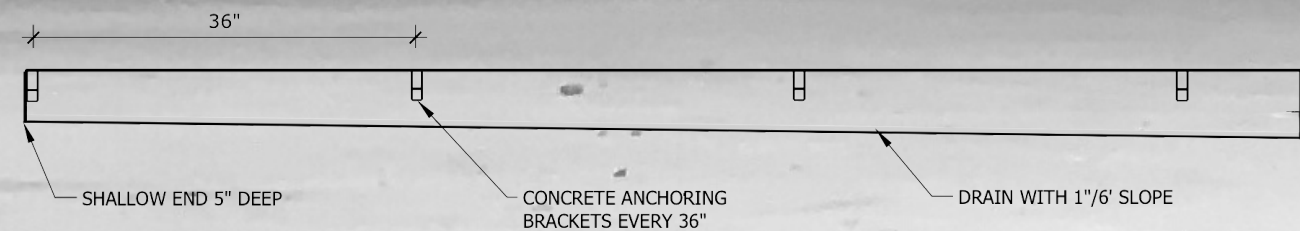

1 SLOT DRAIN SIDE VIEW  
Scale: 3/4" = 1'-0"

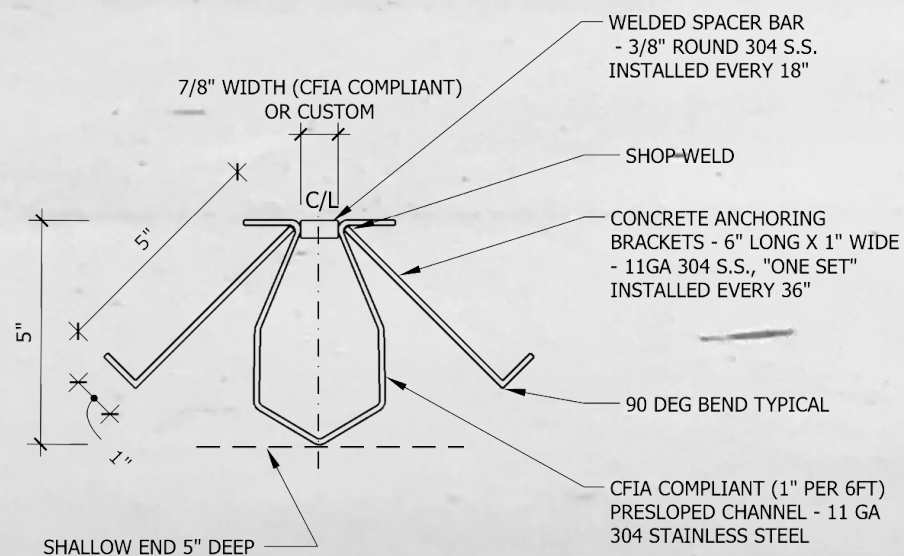

2 SLOT DRAIN FRONT VIEW  
Scale: 3" = 1'-0"

DELIC

# SUMP DRAINS

HEAVY DUTY SUMPS FOR INDIVIDUAL USE OR WITH DELIC SLOT DRAINS.



CFIA COMPLIANT



QUALITY APPROVAL

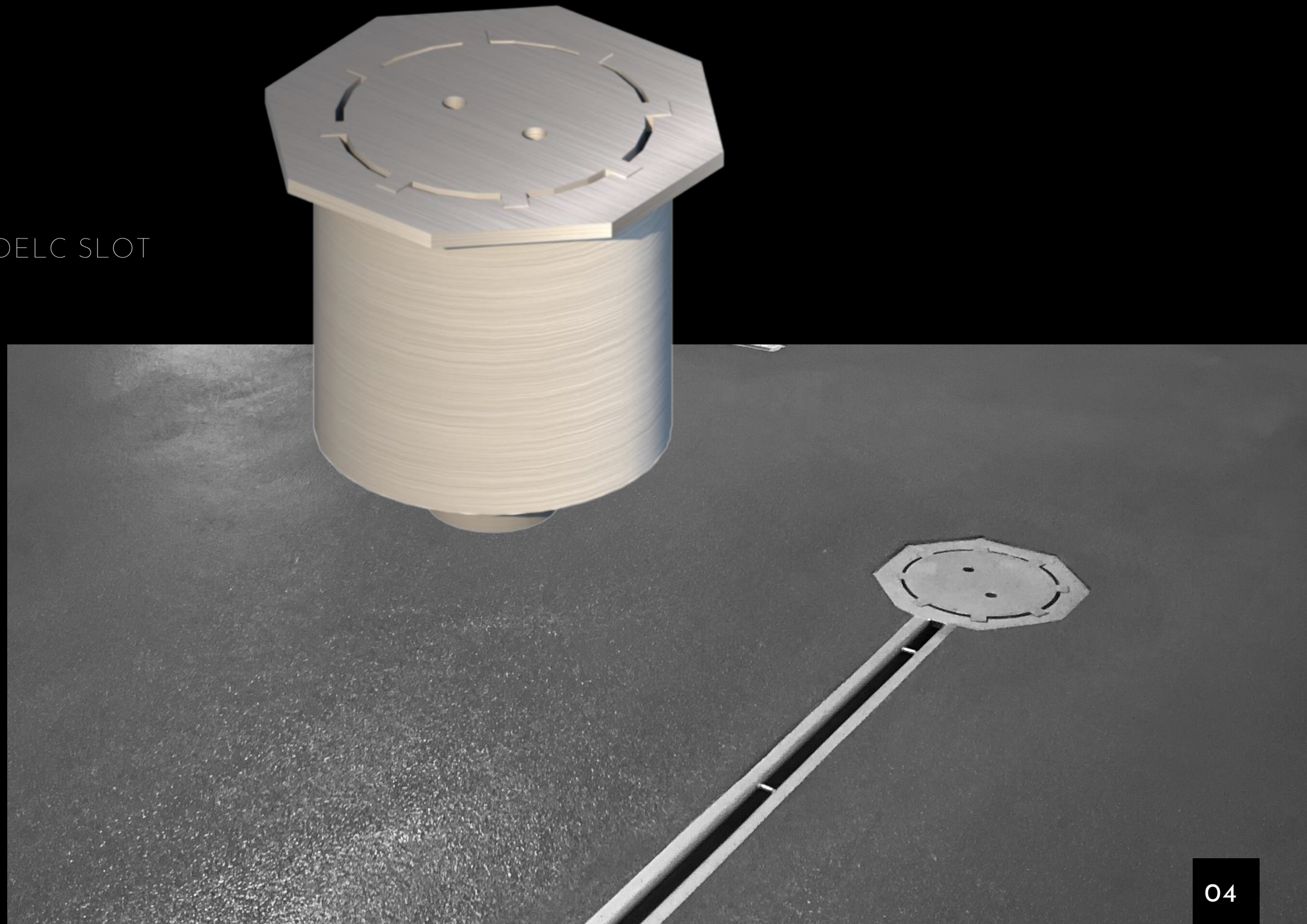

# DELCO SUMP DRAINS

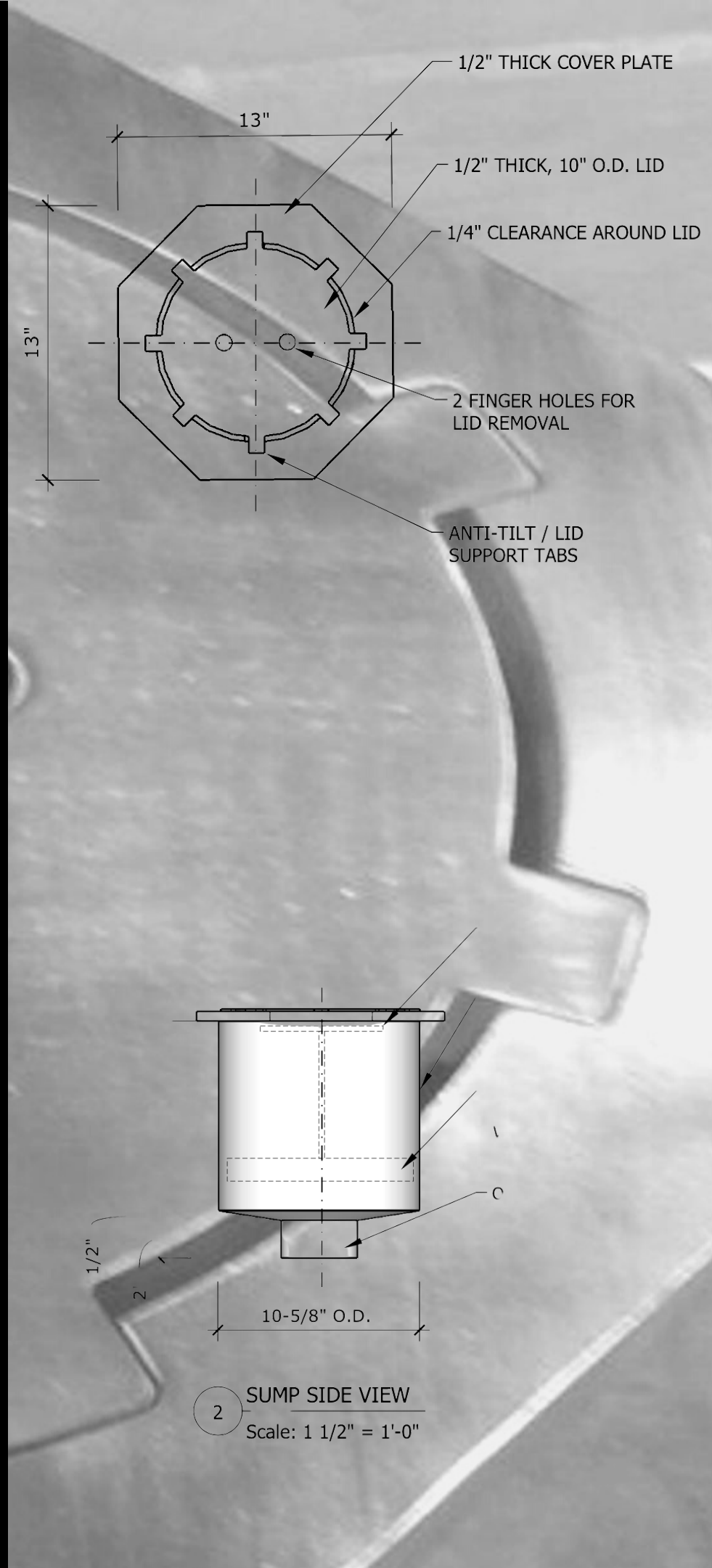

2 SUMP SIDE VIEW  
Scale: 1 1/2" = 1'-0"

## DESIGN

Customizable sump with heavy duty non-tilt lid and removable strainer. Designed with maximum drainage from all sides.

## MATERIAL HANDLING

Suitable for all foods, beverages, water, oils and mild acids, as well as slurry's in the pulp and paper industry

## DURABLE

Load bearing 1/2" stainless steel lid for heavy traffic

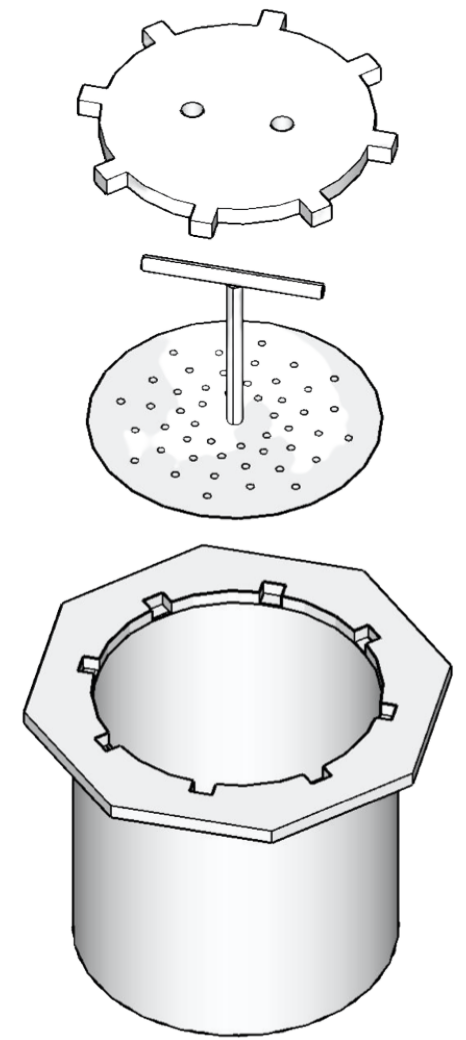

3 SUMP EXPLODED VIEW  
Scale: 1 1/2" = 1'-0"