

1 **SUMP TOP VIEW**  
Scale: 1 1/2" = 1'-0"

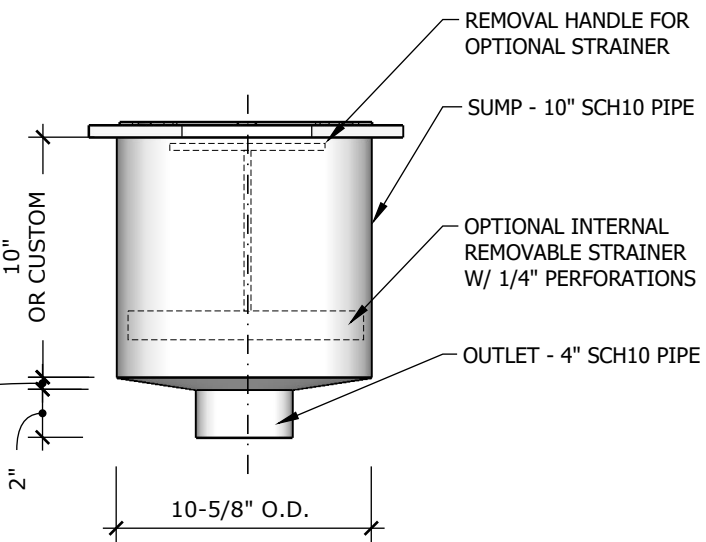

2 **SUMP SIDE VIEW**  
Scale: 1 1/2" = 1'-0"

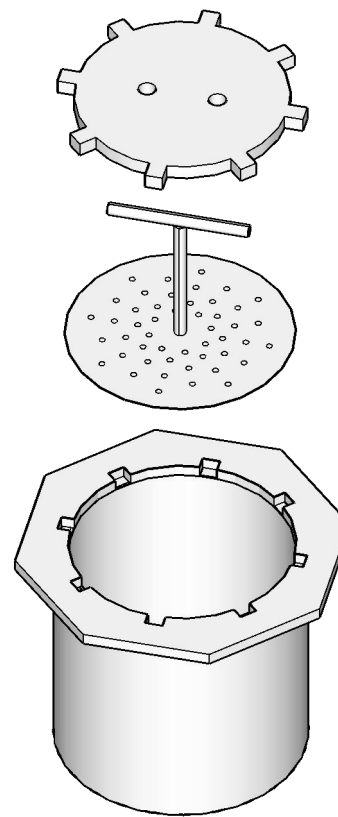

3 **SUMP EXPLODED VIEW**  
Scale: 1 1/2" = 1'-0"



4 **SUMP PERSPECTIVE**  
Scale: Not to Scale

\*SUMPS ALSO AVAILABLE IN VARIOUS DIAMETERS AND DEPTHS, AND WITH OPTIONAL SCREEN BASKETS WITH VARIOUS PERCENTAGES OF PERFORATIONS

	DETAIL NAME:	SCALE:	REV. NO.:
	DELCO SUMP DRAWINGS	1 1/2" = 1'-0"	002