



**Columbia ParCar Corp.**

# **SERVICE MANUAL**

**P5**

Columbia / ParCar OEM Parts  
**evtechnicalservices.com**

The logo consists of a stylized "EVS" acronym. The "E" and "S" are red with white horizontal stripes, and the "V" is blue with white horizontal stripes, mimicking the colors and stripes of the American flag. Below the acronym, the words "TECHNICAL SERVICES" are written in a small, black, sans-serif font.

**SECTION 1 – SAFETY**

Overview	1-1
Safety Information	1-1
Antidotes	1-1
Icons in Procedures	1-2
Safety Preparations	1-2
Decal	1-2

**SECTION 2 – GENERAL INFORMATION**

Vehicle Identification Number (VIN)	2-1
VIN Matrix Personal Transport Vehicle	2-1
VIN Matrix Slow Moving Vehicle	2-1
VIN Label	2-1
Vehicle Specifications	2-2
Controls	2-2
Operation	2-3
Pre-Operation Inspections	2-3
Pre-Operation Checklist	2-3

**SECTION 3 – MAINTENANCE**

<b>Electric Vehicle Service</b>	3-1
Periodic Maintenance	3-1
Periodic Service Calendar	3-1
Check List -Body/Frame/Chassis	3-1
Checklist – Operating Controls	3-2
Checklist – Electrical	3-2
Checklist – Fluids	3-2
Check List – Tires & Wheels	3-3
Checklist – Electric Motor	3-3
Batteries	3-3
Axle	3-3
Chassis Cleaning	3-3
Seat Cleaning	3-3
Lifting Instructions	3-4
Tool Required	3-4
Floor Jack	3-4
Lifting Vehicle Front	3-4
Lifting Vehicle Rear	3-4
Jack Stands	3-4
Vehicle Storage	3-5
Returning Vehicle to Service	3-5
Transporting a Vehicle	3-5
Torques	3-6

**SECTION 4 – TROUBLESHOOTING**

Pre-troubleshooting Steps	4-1
Battery Testing	4-1
Troubleshooting Specific Complaints	4-2
Troubleshooting With PCPAK	4-2
Troubleshooting With Handheld Calibrator	4-4
Vehicle Will Not Move; Forward or Reverse – LED Diagnostic Guide	4-4
Vehicle Drives Slowly	4-5
Vehicle Drives in Forward or Reverse Only	4-5
Vehicle Drives But Operation is Jerky or Inconsistent	4-5
Vehicle Power Cuts Out	4-5

**SECTION 4 – TROUBLESHOOTING Cont.**

Flash Codes and Corrective/Investigative Actions	4-6
Component Troubleshooting	4-7
Battery Discharge Indicator	4-7
Brake Lights and Auxiliary Switch	4-7
Reverse Beeper	4-7
Head Light & Tail Light	4-7
Power Outlet	4-8
Brake Light	4-8
Brakes	4-8
Slow Or Incomplete Release Of Brakes	4-8
Wheel Bearings	4-8
Air In Hydraulic Lines	4-8
Severe Reaction To Pedal Pressure And Uneven Stopping	4-8
Brakes Squealing, Clicking Or Scraping Noises	4-8

**SECTION 5 – ACCELERATOR & BRAKE SYSTEM**

Vehicle Service	5-1
Accelerator Pedal	5-1
Mechanical Rear Drum Brake Disassembly	5-2
Brake Caliper Service	5-3
Brake Cable Replacement	5-4
Brake Linkage Adjustment	5-5
Parking Brake Adjustment	5-5
Drum Brake Shoe Adjustment	5-5

**SECTION 6 – FRONT WHEEL, SUSPENSION & STEERING**

General	6-1
Specifications	6-1\
Front Wheels and Hub	6-1
Roller Bearings	6-1
Install Front Wheel Hubs & Wheels	6-1
Tires	6-2
Front Wheel Hub Assembly	6-2
Steering Wheel Removal	6-2
Installing Steering Wheel	6-2
Rack & Pinion Steering Assembly	6-2
Removing	6-2
Installing	6-3
Front Suspension	6-3
Replacing Front Shock Coil Over	6-3
Disassembling Steering Spindles and A-Arm	6-3
Assembling Steering Spindles and A-Arm	6-3
Steering Adjustments	6-4
Toe-In Adjustment	6-4
Camber Adjustment	6-4

**SECTION 7 – REAR AXLE**

Rear Wheels	7-1
Removing Rear Wheels	7-1
Rear Axle Wheel Bearings	7-1
Installing Rear Wheels	7-1
Tires	7-1
Rear Suspension	7-1
Replacing Rear Leaf Spring	7-1
Replacing Rear Shocks (If Equipped)	7-1
Rear Axle Assembly	7-1
Removing Rear Axle	7-1
Disassembling Rear Axle	7-2
Axle Breakdown	7-3

**SECTION 8 – BODY AND CHASSIS**

Front Body	8-1
Replacing Front Headlight	8-1
Replacing Rear, Stop, Turn, & Tail Light/Bulb	8-1
Replacing Front Turn Signal/Bulb	8-1
Seat Removal	8-1
Rear/Mid Body Removal	8-2
Console Controls	8-2
Directional Switch Removal	8-2
Fuse Block – 12V Electrical	8-3
Horn	8-3
Brake Lamp Control	8-3
DC DC Converter	8-3
Fuse Block – 48V Electrical	8-3
Controller	8-3
Charger, Receptacle & Remote Led	8-3

**SECTION 9 - BATTERY AND BATTERY CHARGER**

Important information	9-1
Safety Information	9-1
Antidotes	9-1
Battery Inspection & Maintenance	9-1
Battery Cleaning	9-1
Battery Service (Water)	9-2
Adding Water	9-2
Single Point Watering System	9-2
Battery Charging	9-3
Charger Safety Information	9-3
Battery Brand Algorithms	9-4
Delta Q Charger Operation	9-5
Single LED Display	9-5
Delta-Q Display	9-5

Red Light Charger Error Codes	9-6
PRO CHARGER OPERATION	9-6
Battery Percent Charge Indicators	9-6
Troubleshooting	9-7
Fault Code Indications	9-7
Charging Procedure	9-8
Testing Batteries	9-8
Specific Gravity Test	9-8
Hydrometer Test	9-8
Results Interpretation	9-8
Discharge (Load) Test	9-8
Test Preparation	9-8
Test Procedure	9-9
Results Interpretation	9-9
Storing Batteries	9-9
Replacing Batteries	9-10
Removing Batteries	9-10
Installing Batteries	9-10
Excessively Discharged Batteries	9-10

**SECTION 10 – TRACTION DRIVE SYSTEM**

Traction Motor	10-1
Maintenance	10-1
External Inspection	10-1
Internal Inspection	10-1
Removal	10-1
Disassembly	10-2
Armature Inspection	10-2
Armature Testing	10-3
Brushes	10-3
Brush Springs	10-3
Motors Exploded View	10-4
Bearing	10-5
Frame and Field Coils	10-5
Field Coil Maintenance	10-5
Inspection	10-5
Motor Reassembly	10-5
Motor Installation	10-6
Controller	10-7
ACEplus System	10-7
Testing	10-7
Removing	10-7
Contacto(r)s	10-7

**CHANGE HISTORY – P5**

DATE	DESCRIPTION	BY
10/24/13	Issued	TS
2/12/14	Added key switch removal procedure	TS
9/29/14	Changed steering adjustment	TS
5/27/15	Added PRO Charging System	TS



GENERAL

This service manual has been prepared with two purposes. First, it will introduce the trained maintenance professional to the latest field tested and factory approved major repair methods. Secondly, it will acquaint the reader with the construction of the Columbia ParCar vehicles and assist him/her in performing basic maintenance and repair. We sincerely believe that this manual will make the association with Columbia ParCar vehicles a more pleasant and profitable experience.

In addition to the information given in this manual, Service Bulletins are issued to Columbia ParCar dealers which cover interim engineering changes and supplementary information. Service Bulletins should be consulted for complete information on the models covered by this manual.

To ensure the safety of those servicing our vehicles and to protect the vehicles from possible damage resulting from improper service or maintenance, the procedures in this manual should always be followed exactly as specified. Execution of the procedures and troubleshooting tips as outlined will ensure the best possible service from the vehicle(s). To reduce the chance of personal injury and/or property damage, carefully observe the DANGER, WARNING, CAUTION & NOTICE recommendations throughout this manual. See Section 1 Safety for additional details.

If your vehicle is a Low Speed Vehicle (LSV), commonly referred to as NEV or Neighborhood Electric Vehicle, it meets the requirements of the National Highway Traffic & Safety Administration (NHTSA) as stated in the Code of Federal Regulations, Title 49, Part 571, Standard 500, Low Speed Vehicles.

If your vehicle is a Personal Transportation Vehicles (PTV) it does not meet the above requirements and are not designed for over-the-road use and are not equipped for operation on public streets, roads, or highways.

To the best knowledge of Columbia ParCar Corp., the material contained herein is accurate as of the date this publication was approved for printing. Columbia Par-Car Corp. is not liable for errors in this manual or for incidental or consequential damages that result from the use of the material in this manual. Columbia ParCar Corp. reserves the right to change specifications, equipment or designs at any time without notice and without incurring obligation.

This manual contains proprietary information that is protected by copyright. All rights are reserved. No part of this manual may be photocopied, reproduced, or translated to another language without the written consent of Columbia ParCar Corp.

Columbia ParCar Corp. products are manufactured under one or more of the following U.S. Patents - 2986162, 2987934, 3116089, 3144631, 3144860, 3229792, 3434887, 3559773, 3673359, 3680403, 3683716, 3709317, 4648473, Des. 225626.

PREPARATION FOR SERVICE

Proper preparation is very important for efficient service work. A clean work area at the start of each job will allow you to perform the repair as easily and quickly as possible, and reduce the incidence of misplaced tools and parts. Columbia ParCar vehicles that are excessively dirty should be cleaned before work begins. Cleaning will occasionally uncover trouble sources.

Tools, instruments and parts needed for the job should be gathered before work is started. Interrupting a job to locate tools or parts is a needless delay. Special tools required for a job are listed at the beginning of each section.

MODEL IDENTIFICATION

Always give the vehicle identification number (VIN) when ordering parts or making inquiries about the vehicle. Use of the full and complete vehicle identification number will ensure that the dealer or service provider is supplying you with the correct parts for the vehicle. See Section 2-General Information for VIN location and additional information.

USE GENUINE REPLACEMENT PARTS

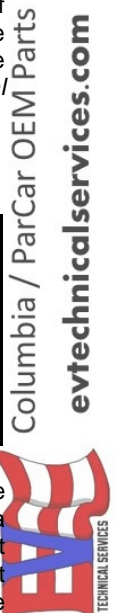
**WARNING**

**When replacement parts are required, use only genuine Columbia ParCar parts or parts with equivalent characteristics including type, strength and material. Failure to do so could result in product malfunction and possible injury to the operator and/or passenger.**

To ensure a satisfactory and lasting repair, follow the service manual instructions carefully and use only genuine Columbia ParCar vehicle replacement parts. This is the insurance that the parts you are using will fit right, operate properly and last longer. When you use genuine Columbia ParCar vehicle parts, you use the best.

PRODUCT REFERENCES

When reference is made in this manual to a specific brand name product, tool or instrument, an equivalent product, tool or instrument may be used in place of the one mentioned.





**Columbia ParCar Corp.**

**Service Manual**

**Section 1**

**Safety**



Columbia / ParCar OEM Parts  
**evtechnicalservices.com**

**OVERVIEW**

Statements in this manual preceded by the words **DANGER**, **WARNING**, **CAUTION** or **NOTICE** and words printed in **bold face** are very important. We recommend you take special notice of these items.

**⚠ DANGER**

**Danger indicates a hazardous situation which, if not avoided, will result in death or serious injury.**

**⚠ WARNING**

**Warning indicates a hazardous situation which, if not avoided, could result in death or serious injury.**

**⚠ CAUTION**

**Caution indicates a hazardous situation which, if not avoided, could result in minor or moderate injury.**

**NOTICE:** Notices are messages not related to personal injury. They will provide key information to prevent property damage and to assure procedures are more easily understood or implemented.

It is important to note that some warnings against the use of specific service methods, which could damage the vehicle or render it unsafe, are stated in this service manual. However, please remember that these warnings are not all inclusive. Since Columbia ParCar Corporation could not possibly know, evaluate and advise servicing personnel of all possible ways in which service might be performed or of the possible hazardous consequences of each way, we have not undertaken any such broad evaluation.

Accordingly, anyone who uses a service procedure or tool which is not recommended by Columbia ParCar must first thoroughly satisfy him/herself that neither their nor the operator's safety will be jeopardized by the service methods selected.

**SAFETY INFORMATION**

It is Columbia ParCar's specific recommendation that the following safety information must be observed at all times. Not all are repeated throughout this manual, but the recommendations included must be observed whenever these subjects (indoor vehicle operation hazards) are encountered.

**⚠ WARNING**

**Any modifications or changes to the vehicle that affect the stability or increases vehicle speed beyond factory specifications could result in severe personal injury or death. Always, remove keys and turn the master disconnect switch counterclockwise to the OFF position before servicing or repairing your vehicle. See Section 8-Batteries, for specific details.**

**⚠ DANGER**

**All batteries used in electric vehicles can explode! Always wear full face shield when working on or near batteries. Hydrogen fumes are a natural byproduct of charging and discharging and are extremely explosive.**

**Do not smoke around electric vehicle batteries. Keep sparks and flames away from batteries. Battery charging should only be done in a well-ventilated area. Refer to Section 9-Batteries for details.**

**Batteries contain acid which can cause severe burns. Avoid contact with skin, eyes, or clothing. Wear full face shield and rubber gloves when working on or near batteries.**

**ANTIDOTES:**

- **External:** Flush with water. Call a physician immediately.
- **Internal:** Drink large quantities of milk or water. Follow with milk of magnesia or vegetable oil.
- **Eyes:** Flush with water for fifteen minutes. Call a physician immediately.

**⚠ WARNING**

**When working around batteries, use approved insulated tools, remove jewelry such as rings, watches, chains, etc. and place an insulating material such as wood, plastic, rubber, etc. over batteries covering all connections.**

**If any problems are found during scheduled maintenance or inspections, do not operate vehicle until repairs are completed. Failure to make necessary repairs could result in fire, property damage, severe personal injury or death.**

**⚠ DANGER**

**Only trained maintenance professionals should repair or service this vehicle. Persons performing even simple repairs or service should have working knowledge and experience in general electrical and mechanical repair. Follow all procedures exactly and observe all warnings stated in this manual. Use caution and common sense.**

Proper service and repair is important for safe, reliable operation of all Columbia vehicles. The service procedures recommended and described in this service manual are effective methods for performing service operations. Some of these service operations require the use of tools specially designed for this purpose. These special tools should be used when and as recommended.



**ICONS IN PROCEDURES**

Watch out for icons and symbols in procedures. They are there to help you avoid situations that might expose you to an unnecessary hazard or potential injury.

**⚠ DANGER**

Use insulated tools when working near batteries or electrical connections. Use extreme caution to avoid shorting of components or wiring.

**⚠ CAUTION**



Moving parts hazard! When operating any vehicle in a stationary position, avoid chains, belts, and wheels which could snag clothing or cause severe injury to body parts. A running vehicle must be worked on with the greatest care. Use caution and common sense.

**⚠ DANGER**

Do not wear loose clothing or jewelry such as rings, watches, chains, etc. when servicing the vehicle. Failure to do so could result in personal injury or death.

**⚠ WARNING**

Working on Columbia ParCar vehicles without following proper procedures and using proper lifting equipment may result in vehicle damage or personal injury. See Section 3 - Lifting Instructions detailed instructions. Always wear safety glasses or approved eye protection while servicing vehicle. Wear a full face shield when working with batteries. Failure to maintain vehicle properly could result in decreased vehicle performance, reliability or cause severe personal injury. Exceeding rated vehicle load capacities could result in possible severe injury or property damage.

**⚠ CAUTION**

Check the vehicle for proper location and condition of all vehicle safety and operation decals.

**NOTICE:** The modification of vehicles for use in other than its intended purpose is not recommended. Any unauthorized modification may void your vehicle warranty.

**⚠ CAUTION**



**HOT! DO NOT** attempt to service hot electric motor or resistors. Failure to observe this warning could result in severe burns.

The P5 is a vehicle designed to transport one (1) operator and one passenger unless adequate provisions have been installed to accommodate additional passengers.

If your vehicle is a Low Speed Vehicle (LSV) it meets the requirements of the National Highway Traffic & Safety Administration (NHTSA) as stated in the Code of Federal Regulations, Title 49, Part 571, Standard 500, Low Speed Vehicles.

**SAFETY PREPARATIONS**

**⚠ DANGER**

Before performing any service on the vehicle, always turn Power keyswitch to OFF and remove. Turn Directional knob to NEUTRAL. Block tires.

**DECAL**

Warning/Operating Instructions decal should be ordered and replaced as soon as they are discovered to be illegible or missing. Part number for the Personal Transportation Vehicles vehicle decal is 53258-07 (Figure 1-1) or 43960-07 for Low Speed Vehicles (not shown).

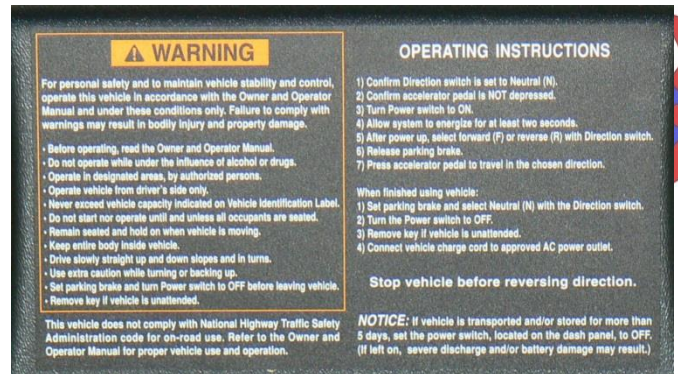


Figure 1-1

To remove a decal, use a heat gun or hair dryer to soften up and remove any damaged sticker. Peel off backing of the new decal and carefully position in place.

Columbia / ParCar OEM Parts  
evtechnicalservices.com





**Columbia ParCar Corp.**

**Service Manual**

**Section 2**

**General Information**



Columbia / ParCar OEM Parts  
**evtechnicalservices.com**



**VEHICLE IDENTIFICATION NUMBER (VIN)**

Each vehicle has a unique VIN. The VIN describes facts and features of the vehicle and contains thirteen (13) digits.

**VIN MATRIX**

**Personal Transport Vehicle (PVT)**

<b>Digit 1 thru 3 = Abbreviation (Model)</b>	P5P
<b>Digit 4 = Power System</b>	F = Sep Ex Regen G = AC Induction
<b>Digit 5 = System Voltage</b>	4 = 48V (8 – 6V) M = AGM (8 -6V)
<b>Digit 6 = VIN Spacer</b>	- = Standard # = Special Product
<b>Digit 7= Controller Amperage</b>	4 = 400 Amp 5 = 500 Amp
<b>Digit 8 = Brake System</b>	Z = Rear Mechanical Y = Rear Hydraulic X = Front & Rear Hydraulic
<b>Digit 9 = Build Year</b>	L = 2012, M = 2013, N = 2014 etc.
<b>Digit 10 Thru 13 – Build Sequence</b>	1234

**Low Speed Vehicle (LSV)**

<b>Digit 1 thru 3:</b>	5FC = CPC Manufacturer Identification
<b>Digit 4: Line</b>	L = Low Speed Vehicle
<b>Digit 5: Series</b>	L = P5 Eagle
<b>Digit 6: Body Type</b>	2 = 2 Person
<b>Digit 7: Engine Type</b>	6 = 48V DC Regen 8 = 48V AC Induction
<b>Digit 8: Restraint</b>	A = Type 1 Seat Belt Assembly B = Type 2 Seat Belt Assembly (3 Point)
<b>Digit 9: Check Digit</b>	Calculated per 49CFR 565.4
<b>Digit 10: Model Year</b>	D = 2013 E = 2014 etc.
<b>Digit 11: Plant Location</b>	1 = Reedsburg
<b>Digit 12-17: Sequential Numbers</b>	00019 - 000999

T



**Figure 2-1**

**NOTICE:** Always provide the complete VIN when contacting your dealer for technical assistance or maintenance and repair parts.

The VIN for Personal Transport Vehicles is printed on a white label, affixed to the glove box (Figure 2-1) and affixed to the steering wheel under the steering wheel cover.

The VIN for Low Speed Vehicles is printed on a white label, affixed to the top of the dash and affixed to the steering wheel under the steering wheel cover. The VIN is also noted on the LSV Vin Label (Figure 2-2) located in the front hood compartment.

MFD BY: COLUMBIA PARCAR CORP  
REEDSBURG, WI 53959, USA  
DATE MFD: / MM/YY  
GVWR: KG (LBS)  
GAWR: FRONT - KG (LBS)  
GAWR: REAR - KG (LBS)  
TIRE SIZE: / (SIZE SPEC)  
COLD INF. PRESSURE (FRONT & REAR)  
KPA (PSI)  
RIMS: X  
MAXIMUM LOAD: KG (LBS)  
OCCUPANTS: (FRONT REAR)  
THIS VEHICLE CONFORMS TO ALL  
APPLICABLE FEDERAL MOTOR VEHICLE  
SAFETY STANDARDS IN EFFECT ON THE  
DATE OF MANUFACTURE SHOWN ABOVE.  
**VIN:**  
TYPE: LOW SPEED VEHICLE

**Figure 2-2**

Columbia / ParCar OEM Parts  
evtechnicalservices.com



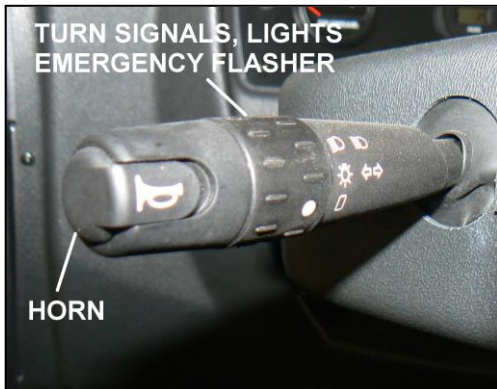
**VEHICLE SPECIFICATIONS**

ITEM	SPECIFICATION
Motor	48 volt, 15.3 hp @ 1750 rpm P5E-P 48 volt, 17.3 hp @ 1750 rpm P5E-L
Drive	Direct coupled to oil bath, helical geared, rear axle
Rear Axle	10.35.1 helical gear reduction with integral differential
Charger	Built in, micro-processor control, fully sealed, anti-drive away interlock, 110-240 V AC, 50/60 Hz
Directional Control	Safety Directional Keyswitch with FL, FH (forward), R (reverse) and N (neutral)

ITEM	SPECIFICATION
Steering	Automotive rack and pinion.
Tire PSI	32 psi 215/50-13 30 psi 205/50-10
Battery Deep Cycle	48 Volt: 8 - 6 volt, heavy duty, 225 Ah
Speed Control	Programmable, solid state, reduced speed reverse with diagnostic LED and calibrator interface
Brakes	Auto-adjusting mechanical drum on rear wheels, foot operated parking brake. .

Columbia ParCar Corporation reserves the right to change specifications, equipment or designs at any time without notice and without incurring obligations.

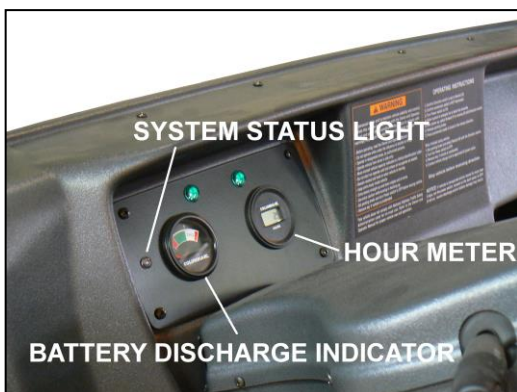
**CONTROLS** - See Figures 2-2 to 2-6.



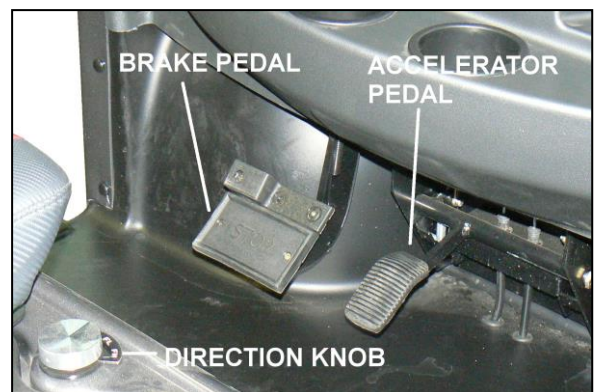
**Figure 2-2**



**Figure 2-3**



**Figure 2-4**



**Figure 2-5**

Columbia / ParCar OEM Parts  
 evtechnicalservices.com



Figure 2-6

**OPERATION**

**NOTICE:** Controls should operate smoothly and easily without sticking or requiring undue effort.

1. Set the keyswitch to the on (marked M) position.
2. Set the direction knob to the desired direction of travel (FL or FH=forward, R=reverse).
3. Depress accelerator with the right foot.
4. To stop the vehicle, release the accelerator pedal and apply the brake pedal slowly and completely.

**PRE-OPERATION CHECKLIST**

SERVICE ITEM	SERVICE METHOD/CHECK
Batteries	Check the BDI (Battery Discharge Indicator) meter for battery charge condition.
Tires	Visually check for wear or damage. Verify proper tire inflation.
Head, Tail or Flasher Lights	Check for proper operation.
Accelerator/Brake Operation	Test drive, check free travel and braking action.
Steering and Linkages	Test drive, check for free movement and proper operation.
Vehicle Body	Visually, check for damaged or loose hardware.
Warning Labels	Visually inspect all labels for readability or missing.
Reverse Warning Beeper	Test drive, check for proper operation.
Charger Plug and Receptacle	Check for damage and proper fit.
Horn	Check for proper operation.

**WARNING**

Be sure safety direction knob is in desired direction of travel before depressing accelerator.

**PRE-OPERATION INSPECTIONS**

Each vehicle has been inspected and adjusted to factory specifications before delivery. Upon receipt of vehicle, perform a pre-delivery inspection of the vehicle. Also, before using the vehicle, there are checks that must be performed to ensure that it is in safe working order.

**WARNING**

Only trained maintenance professionals should service or repair this vehicle. Persons performing even simple repairs or service should have a working knowledge and experience in general electrical and mechanical repair. Follow all procedures and observe all warnings stated in this manual. Use caution and common sense.



**Columbia ParCar Corp.**

**Service Manual**

**Section 3**

**Maintenance**



Columbia / ParCar OEM Parts  
**evtechnicalservices.com**



**ELECTRIC VEHICLE SERVICE**

**⚠ WARNING**

Always turn keyswitch to off, directional keyswitch to neutral, remove key, block tires and separate the battery blue connection before performing any vehicle service to avoid accidental startup of vehicle and possible personal injury.

**NOTICE:** When performing Monthly, Quarterly, Semi-Annual or Annual maintenance, ensure that Daily and Weekly inspections are included.

**NOTICE:** The environment that the vehicle operates in can vary widely. Severe service operations will require the periodic maintenance recommendations to be adjusted to shorter time intervals. The following calendar is one example of how scheduling routine maintenance can be managed.

**PERIODIC MAINTENANCE**

A comprehensive maintenance program is important for the safe, reliable operation of all Columbia ParCar vehicles. The recommended procedures described in this service manual are effective methods for performing periodic maintenance and repair. The maintenance procedures outlined in this manual are recommended when servicing the vehicle. Refer to maintenance check-list for frequency of service. Perform only those maintenance instructions described in this manual. If major repairs are needed, contact the local Columbia dealer for assistance. Columbia dealers have the technical experience, training and original Columbia vehicle parts for the vehicle. Always use original Columbia vehicle parts when servicing the vehicle.

PERIODIC SERVICE CALENDAR		
<b>JANUARY</b> Monthly	<b>FEBRUARY</b> Monthly	<b>MARCH</b> Quarterly
<b>APRIL</b> Monthly	<b>MAY</b> Monthly	<b>JUNE</b> Semi-Annual
<b>JULY</b> Monthly	<b>AUGUST</b> Monthly	<b>SEPTEMBER</b> Quarterly
<b>OCTOBER</b> Monthly	<b>NOVEMBER</b> Monthly	<b>DECEMBER</b> Annual

**NOTICE:** Some procedures require the use of special tools. These special tools must be used when and where recommended.

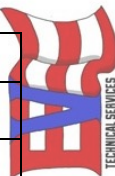
**NOTICE:** Daily maintenance is performed daily before operation of vehicle by owner or operator. Weekly maintenance is performed on a weekly basis to include all daily maintenances and is performed by the owner, operator or trained maintenance personnel.

Columbia / ParCar OEM Parts  
evtechnicalservices.com

**MAINTENANCE SCHEDULE CHECKLIST – BODY/FRAME/CHASSIS**

Component	Procedure	Daily <sup>1</sup>	Weekly <sup>1,2</sup>	Monthly <sup>2</sup>	Quarterly <sup>2</sup> (25 Hours)	Semi-annual <sup>2</sup> (50 Hours)	Annual <sup>2</sup>
Body, Seat & Frame	Visually inspect for damage or tears.	X					
Hardware	Tighten as needed.		X				
Vehicle & Undercarrage	Wash as needed.		X				
Clean Body & Seat	Wash as needed.		X				
Warning & Operating Labels	In place and readable	X					
Windshield	Check for visibility.	X					

<sup>1</sup> Service done by owner. <sup>2</sup> Service done by trained maintenance personnel



**MAINTENANCE SCHEDULE CHECKLIST – OPERATING CONTROLS**

Component	Procedure	Daily <sup>1</sup>	Weekly <sup>1,2</sup>	Monthly <sup>2</sup>	Quarterly <sup>2</sup> (25 Hours)	Semi-annual <sup>2</sup> (50 Hours)	Annual <sup>2</sup>
Steering & Linkage	Check for free movement	X					
Accelerator Linkage	Check for free movement and return	X					
Brakes	Check brake operation	X					
	Check parking brake latching release	X					
	Check brake cables for damage			X			
	Clean & adjust brakes						X
	Check rear brake drum/axle nut torque (65.0 ft. lbs.)						X
Direction knob	Check for smooth forward & reverse operation	X					
Light switch	Check for operation	X					
Turn signals & emergency flasher	Check for operation	X					

<sup>1</sup> Service done by owner. <sup>2</sup> Service done by trained maintenance personnel

**MAINTENANCE SCHEDULE CHECKLIST – ELECTRICAL**

Component	Procedure	Daily <sup>1</sup>	Weekly <sup>1,2</sup>	Monthly <sup>2</sup>	Quarterly <sup>2</sup> (25 Hours)	Semi-annual <sup>2</sup> (50 Hours)	Annual <sup>2</sup>
Batteries	Check charge (fill cells after charging)		X				
	Clean terminals & wash battery case		X				
	Test batteries					X	
Electrical wires	Check for tightness or damage		X				
Reverse warning beeper	Check for operation (use keyswitch)	X					

<sup>1</sup> Service done by owner. <sup>2</sup> Service done by trained maintenance personnel

**MAINTENANCE SCHEDULE CHECKLIST – FLUIDS**

Component	Procedure	Daily <sup>1</sup>	Weekly <sup>1,2</sup>	Monthly <sup>2</sup>	Quarterly <sup>2</sup> (25 Hours)	Semi-annual <sup>2</sup> (50 Hours)	Annual <sup>2</sup>
Differential lubricant	Check level						X

<sup>1</sup> Service done by owner. <sup>2</sup> Service done by trained maintenance personnel

Columbia / ParCar OEM Parts  
evtechnicalservices.com  
TECHNICAL SERVICES



MAINTENANCE SCHEDULE CHECKLIST – TIRES AND WHEELS							
Component	Procedure	Daily <sup>1</sup>	Weekly <sup>1,2</sup>	Monthly <sup>2</sup>	Quarterly <sup>2</sup> (25 Hours)	Semi-annual <sup>2</sup> (50 Hours)	Annual <sup>2</sup>
Tires	Check for wear & damage	X					
	Check tire pressure	X					
	Check for dented/damaged rims			X			
Front wheel alignment	Check & adjust as necessary					X	
Lug nuts	Check for tightness	X					
Steering linkage	Check for excessive movement, tightness of hardware			X			

<sup>1</sup> Service done by owner. <sup>2</sup> Service done by trained maintenance personnel

MAINTENANCE SCHEDULE CHECKLIST – ELECTRIC MOTOR							
Component	Procedure	Daily <sup>1</sup>	Weekly <sup>1,2</sup>	Monthly <sup>2</sup>	Quarterly <sup>2</sup> (25 Hours)	Semi-annual <sup>2</sup> (50 Hours)	Annual <sup>2</sup>
Operation	Test drive for proper operation	X					
Brushes	Inspect brush length & remove carbon dust. Inspect & apply anti-seize to splines.						X

<sup>1</sup> Service done by owner. <sup>2</sup> Service done by trained maintenance personnel

Columbia / ParCar OEM Parts  
evtechnicalservices.com

**BATTERIES**

Batteries may be recharged if vehicle has been driven 15 minutes or more since the previous charge. Before charging, be sure the key switch is OFF and key is removed.

Refer to *Chapter 9* for all procedures relating to the batteries.

**REAR AXLE**

Check the rear axle oil only if signs of leakage are detected. Change oil at 24 months or 1250 mile (2000 km) intervals, whichever occurs first. Refer to Section 7.

Capacity – Draining 600 ml., Disassembly 800 ml. Gear lubricant SAE #80 oil.

**CHASSIS CLEANING**

Proper cleaning materials and techniques are vital to the care of the vehicle. Wash underside of vehicle to remove all dirt and debris. Wash chassis and body with a mild detergent only. Do not use abrasives on the paint.

**CAUTION**

**Do not direct high pressure water at the controller, speed switch, or top of batteries. Dry the controller and top surfaces of the batteries immediately after washing.**

**SEAT CLEANING**

Proper cleaning will extend the life of the vehicle seat. Use mild soap or detergent and a soft sponge to clean whenever necessary. For stubborn or imbedded dirt, a soft bristle brush may be used.

**NOTICE: Do not use harsh chemicals or abrasives to clean seat material. Cracking, splitting, or “melting” of seat materials may occur. If seat material becomes torn or split, it should be replaced**

**LIFTING INSTRUCTIONS**

**⚠ WARNING**

Use extreme caution lifting or working around lifted vehicle. Vehicle should be lifted only when parked on a flat, hard and level surface. Do not work under the vehicle unless it is firmly supported on jack stands. When lifting the vehicle for service, use a sturdy lifting device such as a floor jack or hydraulic lift. Always, wedge wheels and set parking brake of the vehicle to keep it from rolling. When using a lifting device, lift only on sturdy parts under the vehicle, an example being the frame. When using a floor jack, lift only on sturdy parts under the vehicle, an example being the frame or axle housing. Place jack stands or support blocks under vehicle frame to support vehicle weight for added safety. Watch for cables, linkages or wire harness.

**⚠ CAUTION**

If any vehicle is raised while loaded, check that the load is secured before lifting vehicle. Failure to do so could cause damage to load, vehicle, or personal injury. Before lifting, always chock tires. Use care to prevent tipping or rolling over. Be careful not to damage the brake cables during lifting operation.

**Tools Required**

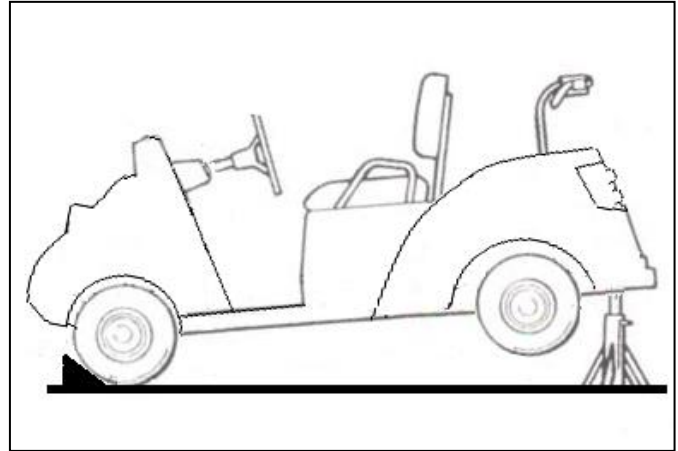
- Floor jack
- Chocks or wooden blocks
- Jack stands or support blocks

**FLOOR JACK PROCEDURE**

If a floor jack is used to lift the vehicle, check that the floor jack is rated at a capacity greater than the vehicle weight. Lift the vehicle sufficiently from the floor to allow the placement of jack stands or wooden blocks and hold the weight of the vehicle during service. See Figure 3-1.

**Lifting the Rear of Vehicle**

- 1 To lift the rear, place floor jack under the rear chassis frame. Do not use the bumper for lifting. Raise vehicle sufficiently to place jack stands underneath frame.
2. Place jack stands under frame at right and left sides to allow access under the vehicle.
3. When work is completed, place floor jack under rear chassis frame, lift the vehicle and remove the jack stands, then lower vehicle to the floor.



**Figure 3-1**

**Lifting the Front of Vehicle**

1. To lift the front, use a suitable flat surface on a floor jack under the front chassis. Do not use the bumper for lifting. Raise vehicle sufficiently to place jack stands underneath chassis frame.
2. Place jack stands under frame at right and left sides to allow access under the vehicle.
3. When work is completed, place floor jack under front chassis, lift the vehicle and remove the jack stands, then lower vehicle to the floor.

**JACK STANDS**

Jack stands need to be of sufficient rated load capacity to hold the vehicle safely. See Section 2 - Vehicle Specification Chart for empty vehicle weight.

**VEHICLE STORAGE**

**⚠ WARNING**

**Turn keyswitch OFF. Remove key during storage to prevent unintentional starting of vehicle.**

**⚠ WARNING**

**Do not attempt to charge a battery that is frozen or if battery case is excessively bulged. Frozen batteries can explode. Properly dispose of battery.**

Electric vehicles stored over 6 to 8 weeks must be protected to maintain battery life. Several guidelines should be observed when storing the electric vehicle.

1. Charge batteries fully. With electrolyte full in all cells, store batteries in as cool place as possible. If stored above 50°F (10°C), check state of charge every 4 to 6 weeks and charge as necessary to maintain 1.250 to 1.270 specific gravity. If vehicles are stored in temperatures below 40°F (4°C) check state of charge every 15 to 18 weeks. Use table below to determine freezing point of battery and maximum recommended storage temperature. Refer to *Section 9 – Batteries* in this manual for a charging procedure. Remove battery pack negative cable.
2. Wash off any corrosion around the terminals with a solution of baking soda and water. Do not allow this solution to enter batteries.
3. Store vehicle in a cool dry place to prevent battery discharge.
4. Maintain tire pressure at 35 psi during storage for 215/50-13 tires and 30 psi for 205/50-10 tires.
5. Grease steering hubs and continue quarterly lubrication during storage period. Refer to periodic maintenance in the beginning of this section.
6. Clean vehicle body, seat, battery compartment and vehicle underside.
7. Do not engage parking brake. Block wheels to prevent movement.
8. Periodically charge battery during storage to prevent damage to battery. See step 1.

**SPECIFIC GRAVITY & FREEZE POINTS**

Specific Gravity	1.250		1.225		1.200		1.117		1.110	
	F	C	F	C	F	C	F	C	F	C
Electrolyte Freeze Point	65	-54	-39	-39	-18	-28	-2	-19	+17	-8

**RETURNING VEHICLE TO SERVICE:**

1. Reconnect battery negative terminal.
2. Fully recharge batteries.
3. Check tire pressure and readjust if necessary.
4. Perform initial maintenance per periodic maintenance in the beginning of this section.
5. After the batteries have been fully charged, connect the single point watering system to its water supply for 3-5 seconds, then disconnect regardless of whether or not the batteries are completely full.
6. Return the vehicle to its regular service.
7. Place the vehicle back into its regular watering schedule (waiting at least 1 week until next watering).

**TRANSPORTING A VEHICLE**

**NOTICE: Never tow a vehicle behind an auto or truck unless on an approved trailer.**

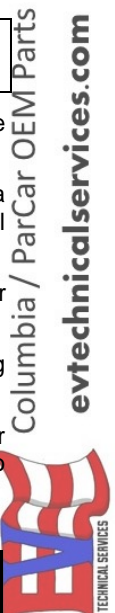
When trailering a vehicle over long distances or on the highway observe the following:

1. Use trailers specifically designed to carry your Columbia ParCar vehicle that meets all federal, state and local requirements.
2. Secure vehicle to the trailer following trailer manufacturer's instruction.
3. The key should be removed from the vehicle, the parking brake firmly locked, and the wheels blocked.
4. On vehicles equipped with high or wide additions or accessories be certain they are secured properly to prevent loss or damage while trailering.

**⚠ CAUTION**

**Increased transporting speed adds undo stress to windshield, cab or suntop and will increases chance of loss, damage, accident or injury.**

**Use care when transporting on windy days. Example: A 60 MPH speed into a 40 MPH head wind is equal to traveling at 100 MPH. Golf and Industrial vehicles are not rated to withstand this level of stress and parts could be blown from top or cab, causing accident or injury.**



**TORQUES AND METRIC CONVERSION FACTORS**

Individual component torques and metric equivalents are listed where the maintenance is to be performed throughout this manual. When a specific fastener torque is not specified,

Use the following Torque Table as a general guide in determining proper torque. When a metric equivalent is not listed, use the Conversion Factors Chart to convert to metric values.

Torque Table													
Torque to the value in this table unless specified otherwise.													
Fine or coarse thread fastener	Grade Designation	Tensile Strength Minimum	Material	Screw, Stud or bolt shank size or diameter									
				Torque figures are in ft. lbs.									
				1/4	5/16	3/8	7/16	1/2	9/16	5/8	3/4	7/8	1
cap screw	S.A.E. 2 A.S.T.M. A-307 steel	64,000 psi	low carbon steel	6	11	19	30	45	66	90	150	202	300
cap screw	S.A.E. 3 steel	100,000 psi	medium carbon steel	9	17	30	47	69	103	145	234	372	551
cap screw	S.A.E. 5 A.S.T.M. A-499 steel	105,000 psi	medium carbon steel or low alloy heat treated	9	18	31	50	75	110	150	250	378	583
cap screw	A.S.T.M A-354BB steel			9	18	31	50	75	110	150	250	378	583
cap screw	A.S.T.M A-325							100		200	355	525	790
cap screw	A.S.T.M A-354-BC steel	125,000 psi	low alloy or med. carbon steel quenched tempered	11	20	34	54	81	119	167	269	427	611
cap screw	S.A.E. 6 steel	133,000 psi	med. carbon steel quenched tempered	12.5	24	43	69	106	150	209	350	550	825
cap screw	S.A.E. 7 steel		med. carbon alloy quenched tempered roll threaded										
cap screw	S.A.E. 8 steel	150,000 psi	med. carbon alloy quenched tempered	13	28	46	75	115	165	225	370	591	893

Columbia / ParCar OEM Parts  
evtechnicalservices.com



<b>Conversion Factors Chart</b>					
Into Metric			Out of Metric		
to convert from	To	Multiply by	to convert from	To	Multiply by
<b>Work force measurements</b>					
inch-pound	N. m.	0.1130	Newton-meter	in. lb.	8.8496
foot-pound	N. m.	0.3558	Newton-meter	in. lb.	0.7376
<b>Length Measurements</b>					
inch	mm	25.4	millimeter	in.	0.0394
foot	m	0.3048	meter	ft.	3.281
miles	kilometers	1.6	kilometers	miles	0.621
<b>Liquid Volume Measurements</b>					
fluid ounces	milliliters	29.57	milliliters	fluid ounces	0.034
pints	liters	0.473	liters	pints	2.113
quarts	liters	0.95	liters	quarts	1.06
gallons	liters	3.8	liters	gallons	0.26
<b>Temperature</b>					
Fahrenheit	°C	$^{\circ}\text{C} = (^{\circ}\text{F} - 32) / 1.8$	Celsius	°F	$^{\circ}\text{F} = 1.8^{\circ}\text{C} + 32$

Columbia / ParCar OEM Parts  
**evtechnicalservices.com**  




**Columbia ParCar Corp.**

**Service Manual**

**Section 4**

**Troubleshooting**



Columbia / ParCar OEM Parts  
[evtechnicalservices.com](http://evtechnicalservices.com)



**WARNING**

**Always turn keyswitch to OFF and remove. Directional knob to Neutral, block tires and disconnect the battery negative (-) cable before performing any vehicle service to avoid accidental startup of vehicle and possible injury.**

**PRE-TROUBLESHOOTING STEPS**

Before troubleshooting a vehicle for any problem or symptoms, certain steps must be followed.

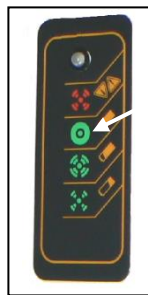
- Ensure the vehicle is safe for service. Visually inspect for any obvious signs of hazards such as sharp edges in the body or other parts, open wire insulation or wire connections, or discolored parts of the vehicle indicating heat or chemical presence.
- Record the VIN. This number is necessary to obtain technical help or support, submit warranty, and is essential in order to understand completely the vehicle that is being serviced.

**BATTERY TESTING**

The first step in servicing any electric vehicle that is not operating properly is to completely test the batteries. The batteries are the source of power for the vehicle drive and auxiliary systems, therefore are the most integral part of the electric vehicle troubleshooting. Battery testing should be done in the following order.

Inspect/Test Condition	Corrective Action
Perform a visual examination of batteries and connections. Examine for signs of corrosion and clean/or replace any affected terminals or cables.	The batteries can be cleaned by hose washing with a standard garden hose or with a soft bristle brush (ensure battery caps are present and tight before washing batteries).
Examine the battery hold-down. If the material from the hold-down has been dissolved by the sulfuric acid in the batteries, the hold down can act as a drain on the battery pack.	Replace the hold-down if it appears damaged.
Test each battery with a VOM (volt-ohm meter). With VOM set to a scale able to read DC volts at up to 100 volts (or greater), check each battery individually, and test the entire pack together.	Place the VOM probes on the battery positive and negative post of each battery. Write down the reading from each battery. Each should contain at least 6.0 volts and no battery should be more than .5 volts lower than the highest reading. If any battery tests low on charge, charge the battery individually with an auxiliary charger or the entire pack with the onboard charger (allow vehicle to charge until the green charger light is illuminated, indicating full charge. See arrow Figure 4-1). If one or more batteries still test low, the battery should be tested individually and replaced as necessary. <i>NOTE: It is recommended that all batteries in a system be changed together to ensure the batteries are the same brand, vintage, and service life.</i>
Test each battery cell with a battery hydrometer.	Any battery or battery cell that tests low should be fully charged and then rechecked. If the cell continues to test low with a hydrometer, the battery should be replaced. See note above.
A battery may test good with a voltage or hydrometer test when no load is being drawn from it. Test using a battery load tester.	A battery must be able to produce 45 minutes of capacity when tested at 55 amp draw after a complete recharge cycle. A battery that is not able to produce this capacity should be replaced. See note above.

Columbia / ParCar OEM Parts  
evtechnicalservices.com  
TECHNICAL SERVICES



**Figure 4-1**

**TROUBLESHOOTING SPECIFIC COMPLAINTS**

Troubleshooting is a matter of investigation and deduction based on the symptoms and the possible causes. Recording every possible solution to every possible cause would be impossible, but this troubleshooting section is designed to assist in solving issues that may arise in the service life of an electric vehicle.

The main key problems encountered with the vehicle(s) are:

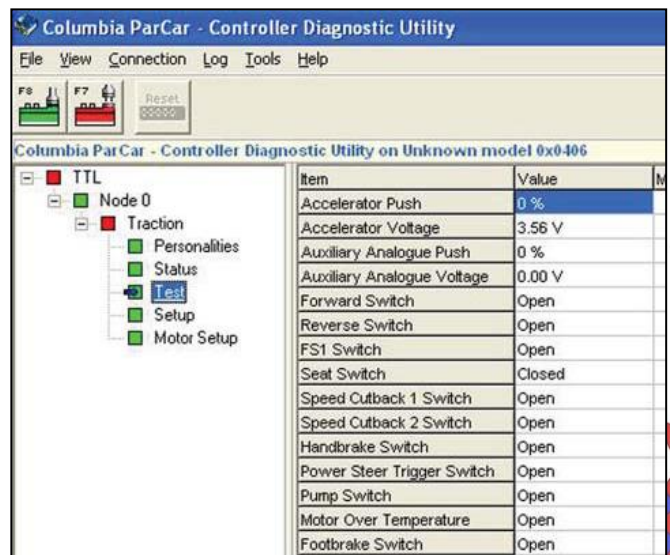
- Vehicle will not move; forward or reverse
- Vehicle operates slowly
- Vehicle drives in forward or reverse only
- Vehicle drives but operation is jerky or inconsistent
- Vehicle power cuts out

**NOTICE: Always follow troubleshooting guide in exact sequence as listed. Performing tests out of sequence will cause inaccurate results and lost time in diagnosing electrical system problems-**

**TROUBLESHOOTING WITH PCPAK**

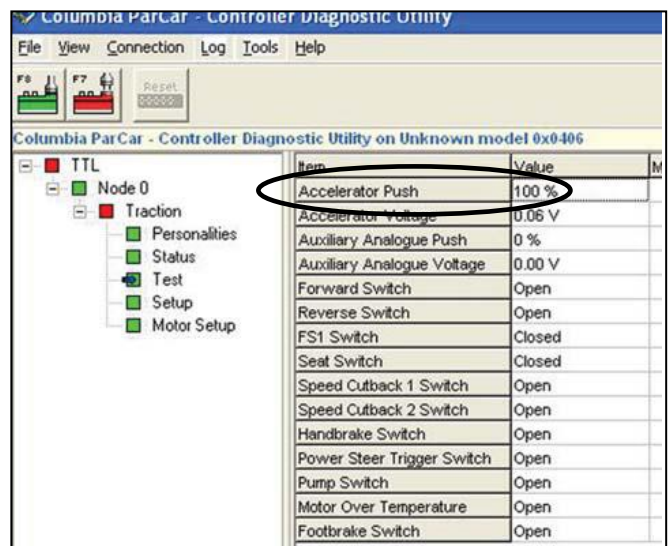
With the vehicle power system off, connect the PCPak (computer diagnostic utility) and then turn the vehicle power on.

1. Open the connection between the controller and the PCPak utility. On the left side of the screen, select the “test” section under the “traction” pull down. This screen will display the inputs the controller is observing at that time (Figure 4-3).



**Figure 4.3**

2. With the Forward / Reverse knob set to Neutral, slowly press the accelerator pedal. The “Accelerator Push” value should rise in value from 0-100% smoothly as you press the pedal (Figure 4-4). If the value does not change, the controller is not receiving input from the accelerator control device (potentiometer or linear accelerator device). Check all cable and wire connections regarding the accelerator control device. If the value does rise, but not to 100%, adjust the accelerator cable that attaches to the accelerator device.

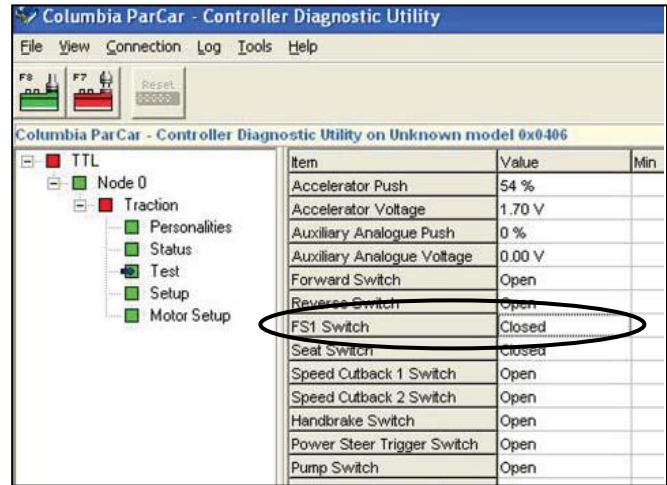


**Figure 4.4**

Columbia / ParCar OEM Parts  
 evehicleparts.com  
 TECHNICAL SERVICES

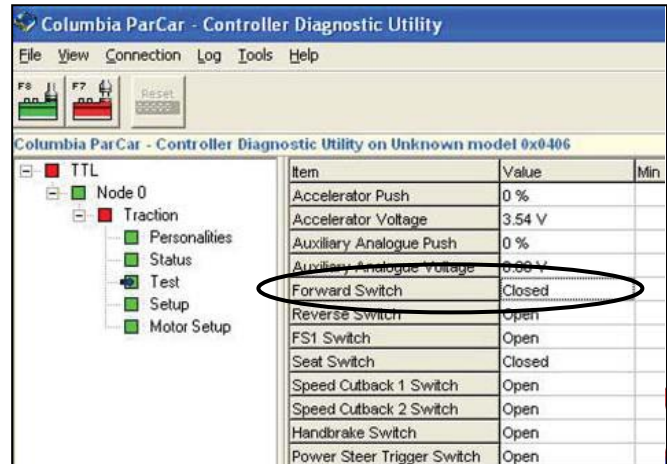
**TROUBLESHOOTING WITH PCPAK (continued)**

3. Check the FS1 Switch input on the same screen. With the accelerator at rest, the value for the FS1 Switch should read “open”. When the accelerator pedal is pressed, the value should change to “closed” (Figure 4-5). If the value fails to close, check the FS1 wiring circuit and test the switch with a VOM. Check the wiring back to the controller (Pin 4).



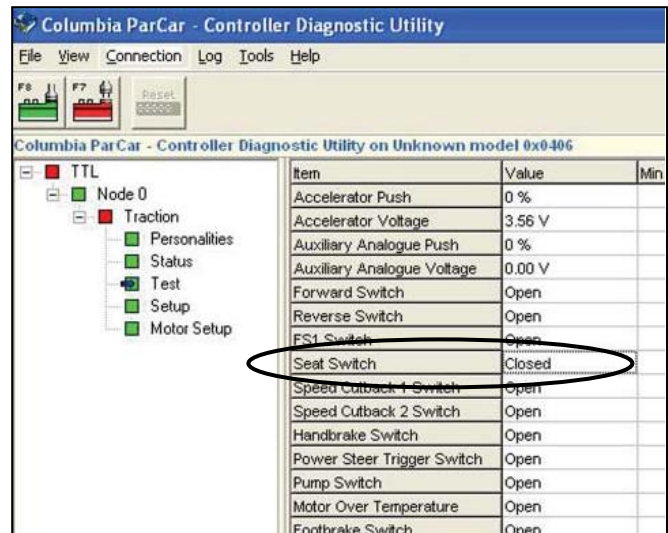
**Figure 4-5**

4. Check the direction input to the controller. Observe the value of the “Forward Switch” item while turning the direction selection knob to “Forward” and to “Neutral”. The switch should read “open” when the knob is in neutral and “closed” when in forward (Figure 4-5). Do the same in reverse by monitoring the “Reverse Switch” item and value. If the switch fails to close in either direction, check the switch with a VOM and the wiring back to the controller (Pin 2 for Forward and Pin 3 for Reverse).



**Figure 4-6**

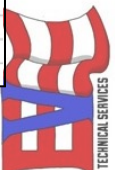
5. Check the “Seat Switch” item and value (Figure 4-6). For vehicles equipped with a seat switch, the value should read “open” when the operator seat is not occupied, and “closed” when the operator seat is occupied. If the switch fails to close, check the wiring from the B- post of the controller to the seat switch, test the seat switch with a VOM, and check the wiring back to the controller (pin 5). For vehicles without a seat switch, the value should read “Closed”. If the switch does not register as closed, check the black 5 wiring from the B- post of the controller to controller plug (pin 5).



**Figure 4-7**

If the vehicle is receiving the correct inputs and fails to operate, contact Columbia Tech Support for further assistance.

Columbia / ParCar OEM Parts  
evtechnicalservices.com



**TROUBLESHOOTING WITH THE HANDHELD CALIBRATOR**

1. Connect the handheld calibrator to the vehicle and enter the "Read-Only" mode (RON). Scroll down by pressing "Select" button until you reach the "19" menu (location 19.01). The "Test" light on the left side of the calibrator will illuminate when the "19" menu is selected. This menu shows the inputs the controller is observing at that time. At 19.01, the calibrator displays the "Accelerator Push" in percentage.
  2. With the Forward / Reverse knob set to Neutral, slowly press the accelerator pedal. The "Accelerator Push" value should rise in value from 0-100% smoothly as you press the pedal. If the value does not change, the controller is not receiving input from the accelerator control device (potentiometer or linear accelerator device). Check all cable and wire connections regarding the accelerator control device. If the value does rise, but not to 100%, adjust the accelerator cable attached to the accelerator device.
  3. Next, check the FS1 Switch input by scrolling to the 19.07 location. At rest, the value for the FS1 Switch should read open, or (3.OP). When the accelerator pedal is pressed, the value should change to closed, or (3.CL). If the value fails to close, check the FS1 wiring circuit and test the switch with a VOM. Check the wiring back to the controller (Pin 4).
  4. Check the direction input to the controller. Observe the value of the "Forward Switch" item at location 19.05 while turning the direction selection switch to "Forward" and to "Neutral". The switch should read open (1.OP) when the switch is in neutral and closed (1.CL) when in forward. Do the same in reverse by monitoring the Reverse Switch at location 19.06 and value. If the switch fails to close in either direction, check the switch with a VOM and the wiring back to the controller (Pin 2 for Forward and Pin 3 for Reverse).
  5. Check the Seat Switch at location 19.09. For vehicles equipped with a seat switch, the value should read open (5.OP) when the operator seat is not occupied, and closed (5.CL) when the operator seat is occupied. If the switch fails to close, check the wiring from the B- post of the controller to the seat switch, test the seat switch with a VOM, and check the wiring back to the controller (pin 5). For vehicles without a seat switch, the value should read closed (5.CL). If the switch does not register as closed, check the black wire #5 wiring from the B- post of the controller to controller plug (pin 5).
- If the vehicle is receiving the correct inputs and fails to operate, contact Columbia Tech Support for further assistance.

Columbia / ParCar OEM Parts  
evtechnicalservices.com  
TECHNICAL SERVICES

VEHICLE WILL NOT MOVE; FORWARD OR REVERSE - LED DIAGNOSTIC GUIDE	
Green LED Flashes	Check/Test
1 Flash	Check all wire connections for good connection and free of corrosion. Call Columbia Technical Support if problem persists.
2 Flash	Perform steps 1 - 5 under <i>Troubleshooting with Handheld Calibrator</i> above.
3 Flash	Check all wire connections. Disconnect all electrical accessories (strobe lights, heaters, etc.) External or internal wiring faults will cause 3 Flash. Eliminate all "non-controller" sources first. Plug in calibrator and read location 13.10 fault code for more precise fault cause(s). Call Columbia Technical Support if problem persists.
4 Flash	Bench test 48 volt main solenoid. Check all wiring. Plug in Calibrator and read location 13.01 for more precise fault cause(s).
5 Flash	Motor stall fault. Check motor for damage. Plug in Calibrator and read location 13.10 for more precise fault cause(s).
6 Flash	Accelerator fault. Check all wiring pertaining to the accelerator switch. Perform steps 1, 3 and 4 under <i>Troubleshooting with Handheld Calibrator</i> above. .
7 Flash	Low or high battery voltage. Check battery voltage with a voltmeter. If battery voltage drops below 32 volts (48 volt system), the controller will shut down. Read pack voltage both stationary and under hard acceleration if possible. If voltage is good while static, but drops significantly while accelerating, weak or damaged batteries may be the cause.
8 Flash	Over temperature cutout. Call Columbia Technical Support.
9 Flash	Out of range. Call Columbia Technical Support.
10 Flash	Bench test 48 volt main solenoid. Check all wiring. Plug in Calibrator and read location 13.01 for more precise fault cause(s).



**VEHICLE DRIVES SLOWLY**

- Check for all physical/visual signs of damage, low tire pressure or jammed linkages.
- Check for brake drag by turning vehicle power off, releasing parking brake, and attempting to roll vehicle a short distance.
- Plug in the Handheld Calibrator and check 5.01, 6.01 and 7.01 for appropriate values (maximum speed settings). While driving check speed incrementally at 14.01 on the handset. Also check the encoder pull up resistor and encoder connector.
- Perform step 2 in *Troubleshooting with Handheld Calibrator*.
- Check for weak, discharged or damaged batteries, or poor connections.

**VEHICLE DRIVES IN FORWARD OR REVERSE ONLY**

- Perform step 4 in *Troubleshooting with Handheld Calibrator*.

**VEHICLE DRIVES BUT OPERATION IS JERKY OR INCONSISTENT**

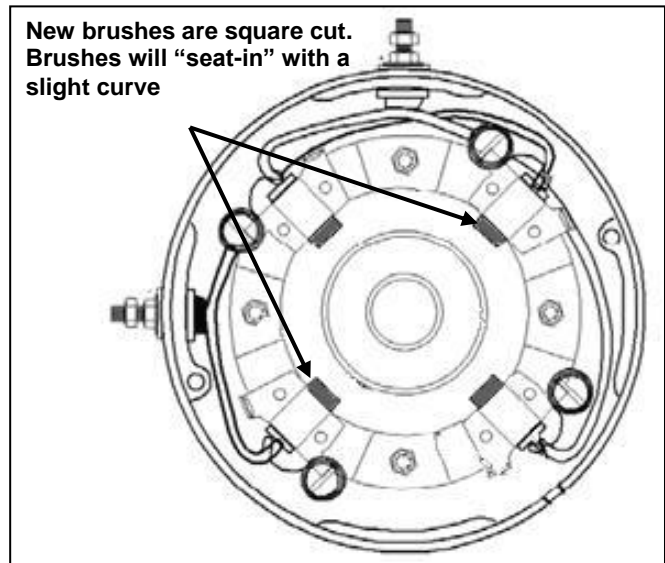
- Check speed switch carefully with analog ohmmeter for gradual, smooth resistance sweep.
- Check motor brushes. Replace if bad or worn (Figure 4-8).

Call Columbia Technical Support if problem persists. Have the following information ready:

- VIN
- Vehicle Checksum (19.15)
- Direction of travel where the operation is "jerky"
- Speeds at which vehicle jerks.

**VEHICLE POWER CUTS OUT**

The fault for a vehicle that exhibits a cut out symptom can only be diagnosed while the vehicle is in a fault condition.



**New brushes are square cut. Brushes will "seat-in" with a slight curve**

**Figure 4-8**

**FLASH CODES AND CORRECTIVE / INVESTIGATIVE ACTION**

Flash Code	Description	Action	Handset ID fault number	Calibrator reference loc	Correction – If fault does not clear
0 Flash (Light does not illuminate or light turns on and then back off.)	Internal Mosfet failure	Disconnect any electrical accessories and retry	25 / 26	13.01	Controller replacement required, contact Tech Support
	Pin 1 Circuit Fault	Trace current from battery positive to Pin 1	-	-	Replace failed connection, component, or wiring.
	Contactora Circuit fault	Trace current to solenoid and contact connections	-	-	Replace failed connection, component, or wiring.
Flash 1	Personality out of range	Check personality Checksum	81 /71	51.91	Controller replacement required, contact Tech Support
Flash 2	Seat Switch Fault	Check seat switch & seat switch circuit	7	80.91	Repair or replace failed connection or component
	Accelerator not at rest when direction selected	Ensure Accelerator Pedal returns to 0 (rest) position	8 or 9	19.01/19.07	Repair or replace failed connection or component
	Two directions selected	Ensure Direction Key switch is functioning properly	10	19.05/19.06	Repair or replace failed connection or component
	Forward or reverse selected at power up	Ensure Direction Key switch is functioning properly	11	19.05/19.06	Repair or replace failed connection or component
	Speed Switch out of range	Check speed switch range	11	19.01/19.02	Repair or replace failed connection or component
	FS1 not open with pedal up	Ensure Pedal returns to 0 and microswitch is functioning properly	11	19.07	Repair or replace failed connection or component
	Controller pins are cross - shorted	Check wire harness connector pins for good connections	Various	19.01 - 19.09	Repair any faulty connections
Flash 3	Auxiliary wiring short	Disconnect auxiliary electrical components and retry	-	13.01	Controller replacement required, contact Tech Support
	Armature Short Detected	Clean and Check motor and wiring for faults	23	13.01	Motor replacement may be required, contact Tech Support
	Internal controller fault	Disconnect auxiliary electrical components and retry	27	13.01	Controller replacement required, contact Tech Support.  Some aftermarket devices with a high capacitance such as a DC DC converter or inverter can cause a 3 Flash
Flash 4	Contactora failed or stuck	Bench test contactora	91	13.01	Replace Solenoid, If good - Controller replacement required, contact Tech Support
	Contactora Failed or contactora wiring fault	Bench test contactora and test contactora wiring	20	13.01	Repair or replace failed connection or component
	Motor open circuit or brushes fault	Clean and Check motor and wiring for faults	22	13.01	Motor replacement may be required, contact Tech Support
Flash 5	Motor stall detected	Clean and Check motor and wiring for faults - review application	15	13.01	Motor replacement may be required, contact Tech Support
Flash 6	Input wire disconnected	Check wiring to speed switch & FS1	4	13.01/19.01/10.91	Repair or replace failed connection or component
	Speed switch out of adjustment	Check speed switch range	11	13.01/19.01/19.02	Repair or replace failed connection or component
	Pedal depressed at start up	Ensure Accelerator Pedal returns to 0 (rest) position	8 or 9	13.01/19.01/19.07	Repair or replace failed connection or component

Columbia / ParCar OEM Parts  
evtechnicalservices.com  
TECHNICAL SERVICES



Flash Codes and Corrective / Investigative Action (continued)

Flash Code	Description	Action	Handset ID fault number	Calibrator reference loc	Correction – If fault does not clear
Flash 7	Battery voltage low	Check Static battery voltage and voltage while operating	12 / 13 or 16	13.01/15.01	Check to see if voltage drops below 32 volts, charge / replace batteries
	Battery voltage high fault	Check Static battery voltage and voltage while operating	12 / 13 or 16	13.01/15.01	Check to see if voltage rises above 63 volts in while operating, see SB 07-012
	Capacitor voltage is too high	Check Static battery voltage and voltage while operating	14	13.01/15.02	Contact tech support with reading from 15.02
8 Flash	Over Temperature cut - out	Review application and allow vehicle to cool	1	13.01/18.01	Contact Tech Support
	Current Cut - Back	Review application and allow vehicle to cool	3	13.01/18.01	Contact Tech Support
Flash 9	Internal motor tripped	Disconnect any electrical accessories and retry	2	-	Controller replacement required, contact Tech Support
10 Flash	Contactor Coil Disconnected	Bench test contactor and test contactor wiring	-	13.01	Contactor or Controller replacement may be required, contact Tech Support
	Value out of range	Check personality Checksum	43	13.01/51.91	Controller replacement may be required, contact Tech Support
	Internal controller fault	Disconnect any electrical accessories and retry	34	13.01	Controller replacement may be required, contact Tech Support

**COMPONENT TROUBLESHOOTING**

In addition to the problems/cause/solutions listed in this section, individual sections also contain some testing and problem solution for individual components. Check the appropriate section first, and if the information is not found, check the following when a component is causing a problem:

**Battery Discharge Indicator (BDI)**

- Fuse failed. Check fuse and replace if failed.
- Open wiring or failed connection. Check wiring and connections.
- Inoperable BDI gauge. Replace gauge
- Weak or failed batteries. Test batteries and charge as necessary.

**Brake Lights and Auxiliary Switch**

- Fuse failed. Check fuse and replace if failed.
- Open wiring or failed connection. Check wiring and connections.
- Bulb failed. Replace bulb.
- Misadjusted or inoperable brake light switch. Check switch adjustment, replace switch if necessary.

**Reverse Beeper**


- Fuse failed. Check fuse and replace if failed.

- Open wiring or failed connection. Check wiring and connections.
- Inoperable reverse buzzer. Replace buzzer.
- Weak or failed batteries. Test batteries and charge as necessary.
- Controller set wrong. Check controller setting using hand held. Reset if necessary.

**Head Light & Tail Light**

- Fuse failed. Check fuse and replace if failed.
- Open wiring or failed connection. Check wiring and connections.
- Bulb burnt out. Replace.
- Failed power key switch. Test and replace contactor as necessary.
- Inoperable switch. Replace switch.
- Check DC-DC convertor fusing and voltage.

Columbia / ParCar OEM Parts  
evtechnicalservices.com



**Power Outlet**

- Fuse failed. Check fuse and replace if failed.
- Open wiring or failed connection. Check wiring and connections.
- Inoperable power outlet. Replace power outlet.

**Brake Light**

- Fuse failed. Check fuse and replace if failed.
- Open wiring or failed connection. Check wiring and connections.
- Bulb burnt out. Replace bulb.
- Failed power key switch. Test and replace contactor as necessary.

**BRAKES****Slow or Incomplete Release of Brakes**

- Shoes and linings. Shoes improperly adjusted. Shoes are self-adjusting; check parts for wear. Shoes distorted or incorrect. Replace with new parts.
- Mechanical parts. Damaged or weak return springs-replace.
- Cables and linkage sticking, dirty or corroded. Lubricate with a commercial solvent like WD40, PB Blaster, etc. Make sure not to contaminate brake pads with solvent.

**Wheel Bearings**

- Damaged or contaminated-replace.
- Grabbing or pulling-replace.

**Air in Hydraulic Lines**

- Bleed hydraulic lines.

**Severe Reaction to Pedal Pressure and Uneven Stopping**

- Shoes and linings. Shoes improperly adjusted. Shoes are self-adjusting; check parts for wear. Shoes distorted or incorrect. Replace with new parts.
- Mechanical parts. Damaged or weak return springs-replace. Cables and linkage sticking, dirty or corroded. Lubricate with a commercial solvent like WD40, PB Blaster, etc.
- Drums. Drums are thin (expanding when hot); oversize (beyond .030") of original specification – replace. Scored, out-of-round – replace.

**Brakes Squealing, Clicking or Scraping Noises**

- Shoes and linings. Shoes twisted, distorted, incorrect or broken – replace. Linings worn out, glazed, loose or contaminated – replace.
- Mechanical parts. Damaged or weak return springs-replace. Backing plate loose or failed – replace.
- Drums. Drums are thin (expanding when hot); oversize (beyond .030") of original specification – replace. Scored, out-of-round – replace.



**COLUMBIA** 

**Columbia ParCar Corp.**

**Service Manual**

**Section 5**

**Accelerator & Brake System**

Columbia / ParCar OEM Parts  
[evtechnicalservices.com](http://evtechnicalservices.com)



## VEHICLE SERVICE

When servicing the electric Columbia vehicle always observe the following:

### ⚠ WARNING

**Always turn keyswitch to OFF and remove. Turn direction knob to Neutral, block tires and disconnect the battery negative (-) cable before performing any vehicle service to avoid accidental startup of vehicle and possible injury.**

## ACCELERATOR PEDAL

Accelerator pedal maintenance consists of periodic inspection. No lubrication or adjustment is necessary.

The accelerator pedal works in conjunction with the linear accelerator and the controller to adjust and control vehicle direction and speed.

All adjustments are made using the handheld Calibrator. See *Section 4-Troubleshooting*.

## MECHANICAL BRAKE SYSTEM

### GENERAL

The mechanical braking system consists of two rear wheel drum brakes, the brake pedal, springs and brake cables to operate the brakes. A brake equalizer pulls evenly on both brake cables. The brake equalizer floats to create equal tension to each brake cable leading to the rear brake assemblies.

These brakes are self-adjusting and should not require adjustment if shoe-to-drum clearance is within normal limits. When brakes are applied, shoes expand outward to drum. If brake shoe travel is excessive, brake adjuster will advance to compensate for wear.

When brakes are released, adjuster returns to normal position. To check brake operation, operate the vehicle with no load, in a large, clear area. Release the accelerator and apply the brake pedal completely. The vehicle should stop abruptly. If it doesn't, see *Mechanical Brake Adjustments* in this section.

The parking brake is applied by depressing the parking brake pad at the top of the brake pedal which locks the brakes in place. Brakes are released when the accelerator or brake pedal is depressed. If brakes fail to hold the car in position when parking brake is applied, see *Mechanical Brake Adjustments*.

### PERIODIC BRAKE INSPECTION

Intervals between brake service and inspection may vary depending on driving habits, type of driving, road and climate conditions, and vehicle load

### ⚠ CAUTION

**Periodic brake inspection is required to prevent potential accident or injury and vehicle damage.**

Periodic inspection should always include the following:

1. With vehicle stationary, depress the brake pedal and check for 1/4" pedal free travel before resistance is felt. Maximum pedal free travel should not exceed 2" measured from floor board to top of pedal. If pedal free travel is excessive, see *Mechanical Brake Adjustments*.
2. Inspect brake parts under vehicle for physical damage, corrosion, or cable fraying. Inspect dust boot at brake actuating lever located behind each rear wheel. If cracked or split, replace dust boot.
3. Operate vehicle on level ground, applying brakes to ensure that both rear brakes apply equally. Check that excessive force is not required to apply brakes. Excessive force required to apply brakes could indicate malfunctioning brake linkage or excessive wear to brake shoes.

## ANNUAL BRAKE INSPECTION

### ⚠ WARNING

**To perform this service, raise vehicle using floor jack and safely support it with jack stands positioned under main frame tubes. See *Section 3 - Lifting Instructions*.**

1. Perform steps 1 & 2 under *Mechanical Rear Drum Brake Disassembly*.
2. Inspect drum for excessive or uneven wear. Look for cracks radiating from stud holes. Maximum drum inside diameter is 6.635" (168.4 mm). If drum is worn beyond service limit, or uneven wear is shown, drum must be replaced. See *Brake Drum Service*.
3. Inspect brake shoes for thickness, uneven wear or physical damage. If brake shoe lining at any point is measured to be less than 1/16" (1.6 mm), brake shoes must be replaced. See *Mechanical Rear Drum Brake Disassembly*.
4. Inspect for oil or grease contamination. Replace brake shoes that are contaminated. See *Mechanical Rear Drum Brake Disassembly*.
5. Inspect dust boot at brake actuating lever. If cracked or split, replace dust boot.
6. Wash mud, brake shoe debris, and dirt from brake assemblies and drum. Apply white lithium grease to contact points between brake shoe and brake back plate. Remove excess grease to prevent brake shoe contamination.



**WARNING**

Do not use compressed air to blow dust from brake assembly. Brake dust contains potentially harmful contaminants.

7. Perform steps 5-8 under *Mechanical Rear Drum Brake Reassembly*.

**MECHANICAL REAR DRUM BRAKE**

**MECHANICAL REAR DRUM BRAKE DISASSEMBLY**

**NOTICE:** Before removal of existing parts, note location of colored springs and other parts for correct reassembly.

Always use a brake spring tool to remove and install springs.

Always lay out brake shoes and other parts in order removed. Reinstall in same order.

Always replace brake shoes that have been contaminated with oils or lubricants.

Always replace any springs that appear stretched or deformed.

1. See Figure 5-1. Engage the brake. Remove four lug nuts and remove rear wheel/tire assembly. Disengage the brake and remove the brake drum. Repeat for other rear wheel.

- Refer to Figure 5-2 for steps 2 - 5.
- Using good, quality brake pliers, remove auto adjuster spring.
  - To remove brake shoes, hold 1/4 turn fastener with a brake spring tool, rotate 1/4 turn and remove fastener and spring. Repeat for other 1/4 turn fastener.
  - Grasp two brake shoes at centers. Pull them outward and fold away from backing plate. Lift one shoe at a time from brake anchor. Remove springs and shoes from brake backing plate.
  - Slide the automatic adjuster screw and automatic adjuster nut from brake assembly. Clean these parts thoroughly.
  - Wash any mud, brake debris, and dirt from brake plate.

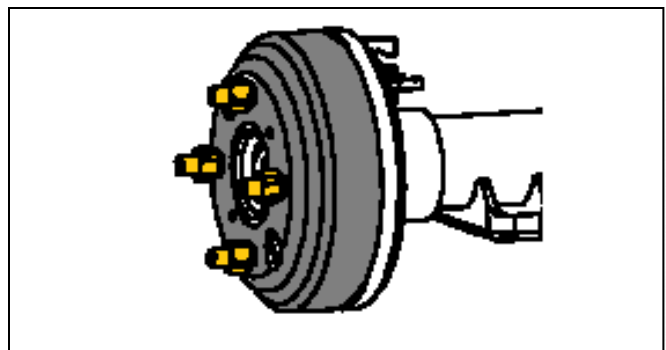
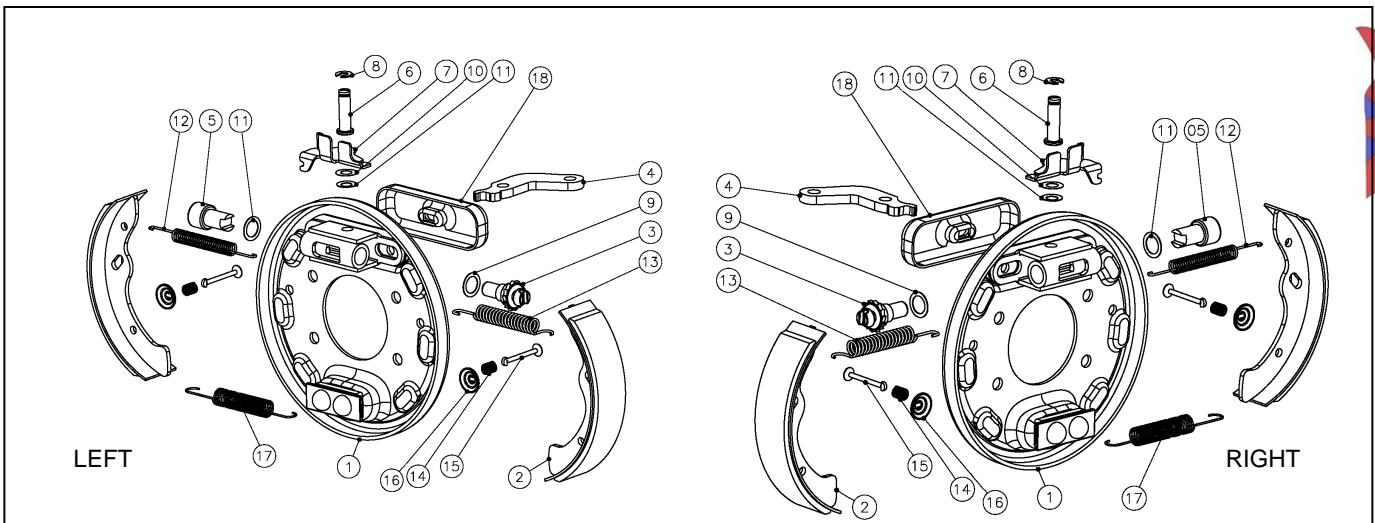


Figure 5-1



1. Cover Assembly	5. Mandrel	9. Washer	13, Spring Adj.	17. Spring Shoe
2. Brake Shoes	6. Pin	10. Washer	14. Spring	18. Dust Cover
3. Adj. Assembly	7. Adj. Piece	11. Spring Washer	15. Pin	
4. Lever	8. E-Ring	12. Spring	16. Spring Washer	

Figure 5-2

**BRAKE DRUM SERVICE**

1. Rebore or replace drum:
  - if rubbing surface is rough or ragged, or if depth of scoring exceeds .010".
  - if inside diameter of drum at open end exceeds inside diameter at closed end by more than .010".
  - if surface variance exceeds .005" on the side.
  - if hard spots cause noticeable effects such as pedal pulsations or brake roughness.
  - if spots are severe, replace drum.
  - if heat checking is plainly visible or can be felt with a fingernail.
  - If checks are severe, replace drum.
  - if out-of-round condition exceeds .006" total indicator reading or if pedal pulsations or brake roughness is noticeable.
2. To measure a drum diameter, place gauge in drum so contact points are at greatest diameter. Be careful to hold both contact points at same depth (distance from outside edge of drum).
3. Rebore limit is .060" over original drum diameter.
4. Difference in diameter of drums on opposite ends of the same axle must not exceed .010", or when turning drums turn them in pairs to same oversize (within .010") to ensure equal braking effort on all wheels.

**CAUTION**

**Never rebore a drum to maximum wear or discard diameter.**

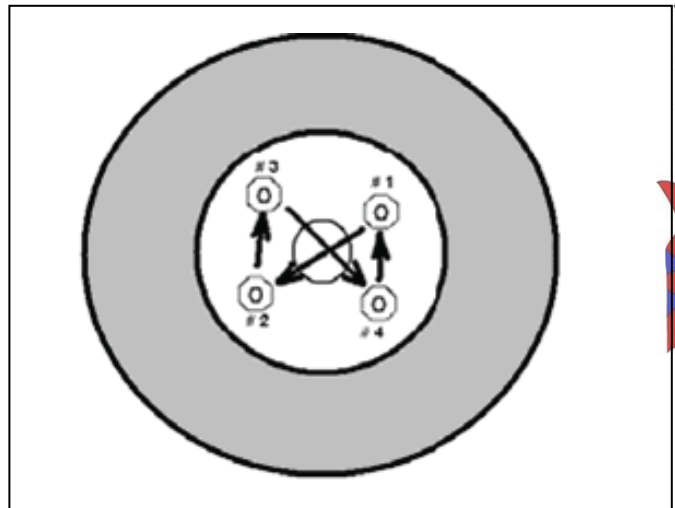
5. When reboring a drum, remove only enough metal to obtain a smooth braking surface. If drum does not clean up when turned to maximum rebore diameter, replace it. Removal of more metal will affect ability of drum to dissipate heat and may cause drum distortion.

**MECHANICAL REAR DRUM BRAKE REASSEMBLY**

1. Apply a small amount of white lithium grease to the threads of automatic adjuster screw and to contact points where brake shoes rest against back plate.
2. Install automatic adjuster screw and nut into automatic adjuster assembly. Reconnect top and bottom shoe return springs to brake shoes in same order as removed.

Brake shoes may not be equal in length. The shoe with the shorter lining should be installed on the brake assembly side closest to the front of the vehicle. Shoe with longer lining installs to the rear.

3. See Figure 5-2. With the springs attached to the brake shoes, hook bottom of each brake shoe, one at a time, into slots on automatic adjuster screw and opposing retainer. Next, hook top end of each brake shoe behind anchor at the top of brake plate. Fold ends of shoes inward towards brake plate. Secure them in place with brake shoe pins, retainer springs and 1/4 turn fasteners.
4. Install auto adjuster spring. Using a flat blade screwdriver, turn the adjuster nut away from the backing plate. Check to make sure the shoes are spreading further apart. Make sure the brake drum still slides on easily.
5. Install the brake drum 3/4 over the brake assembly and using a brake spoon or brake adjusting tool, rotate the brake adjuster until drag is felt against the brake drum. Push the drum fully onto the assembly.
6. Apply pressure to the brake pedal and release, then check to see if additional adjustment is required to create drag on the drums.
7. When adequate drag is achieved (very slight drag), install drum fully onto brake assembly. Engage brake and install rear wheel/tire assembly and four lug nuts.
8. Engage brake and tighten lug nuts in a criss-cross pattern to a maximum 65-70 ft. lbs. (23-25 Nm) (Figure 5-3). Repeat for other rear wheel. Recheck lug nut torque with vehicle on the ground.



**Figure 5-3**



**Brake Cable Replacement**

**⚠ WARNING**

To perform this service, raise vehicle using floor jack and safely support it with jack stands positioned under main frame tubes. See Section 3 - Lifting Instructions.

1. At the rear brake assembly (Figure 5-4), remove cotter pin, clevis pin and e-ring from brake cable clevis. Discard cotter pin and e-ring.
2. Remove cable clevis from rear wheel brake actuator arm. Cut cable tie securing brake cables to frame.
3. Remove brake cable from equalizer (Figure 5-5).
4. Repeat for other cable.
5. In order to install new cables, it may be necessary to loosen equalizer on brake rod (Figure 5-5). Note position of jamnut on equalizer and mark with tape. Loosen jamnut on rod end to provide slack to brake cable.
6. Install brake cable ends at brake equalizer.
7. Route brake cables to rear axle brake actuator arms (Figure 5-4). Secure cable clevis end to each arm with clevis pin and new cotter pin. Secure cable sheath with new e-ring.
8. Secure brake cables to frame with new cable tie.
9. Tighten nut on brake rod (Figure 5-5) to position marked in step 5. With vehicle stationary, depress the brake pedal and check for 1/4" pedal free travel before resistance is felt. Maximum pedal free travel should not exceed 2" measured from floor board to top of pedal. If adjustment is required, see *Mechanical Brake Linkage Adjustment* below.
10. Operate vehicle on level ground, applying brakes to ensure that both rear brakes apply equally. Check that excessive force is not required to apply brakes. Excessive force required to apply brakes could indicate malfunctioning brake linkage or excessive wear to brake shoes.

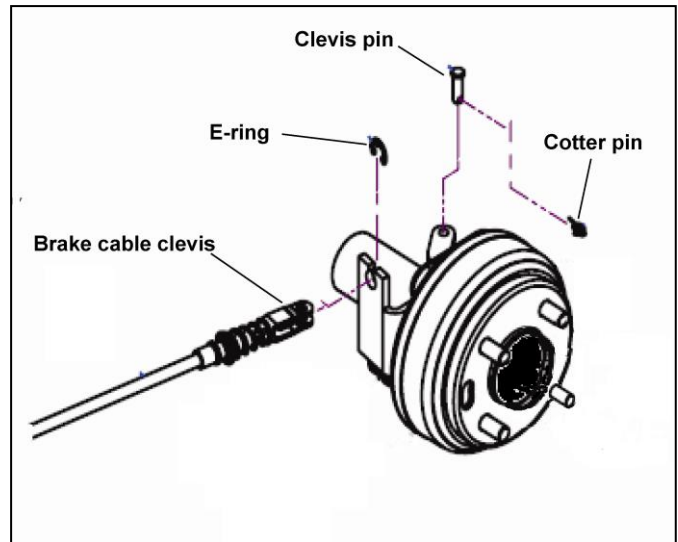


Figure 5-4

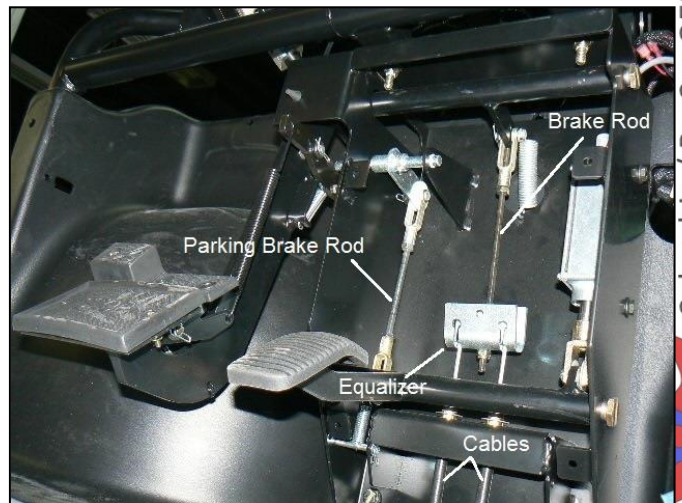


Figure 5-5

Columbia / ParCar OEM Parts  
evtechnicalservices.com  
TECHNICAL SERVICES

**BRAKE LINKAGE ADJUSTMENT**

**NOTICE: Correct brake operation should be confirmed before adjustments are made to cables and mechanical linkage. Check that corrosion has not caused excessive resistance in the operation of the brake cables. If corrosion is present, replace cables before performing adjustments.**

1. Loosen jamnuts on brake rod connecting brake pedal to equalizer.
2. Rotate brake rod to shorten or lengthen it. Adjust length of brake rod until free brake pedal movement is less than 1/4".
3. Tighten jamnuts.

**PARKING BRAKE PEDAL ADJUSTMENT**

After rear brake operation is tested, and brake linkage and cables are properly adjusted, check and adjust the parking brake as follows:

1. With the parking brake engaged, there should be no more than 1/8" accelerator pedal travel before the parking brake is released.
2. Adjustment is made with the jamnuts on the parking brake rod (Fig. 5-5).
3. With the gap properly set, if the vehicle does move when performing steps 4 & 5, perform the *Mechanical Brake Linkage Adjustment* above.

**DRUM BRAKE SHOE ADJUSTMENT**

These brakes are self-adjusting and require no manual adjustment. If brakes do not adjust automatically, check brake cable adjustment or inspect brake assembly for internal damage or friction.

**NOTICE: Do not use repetitive backing up to adjust the brakes. This may damage the adjuster.**



**Columbia ParCar Corp.**

**Service Manual**

**Section 6**

**Front Wheels, Steering & Front Suspension**



Columbia / ParCar OEM Parts  
[evtechnicalservices.com](http://evtechnicalservices.com)

**GENERAL**

The steering system is operated by rotating the steering wheel. The steering wheel rotates the steering shaft connected to the rack and pinion steering assembly. The rack and pinion assembly pushes and pulls on tie rod ends to control front wheel steering.

The front suspension consists of two coil over shock absorbers.

**SPECIFICATIONS**

Steering Gear Rack and Pinion

- Automotive type totally enclosed lifetime lubrication

Camber-Mechanical Adjustment

- Wheels at right angle to the ground - 0°

Toe-In Adjustment - 1/4" toe-in

**NOTICE:** Always inspect the condition of vehicle steering components before making adjustments. Worn, broken or damaged parts must be replaced before proper adjustment can be performed.

**FRONT WHEELS AND HUBS**

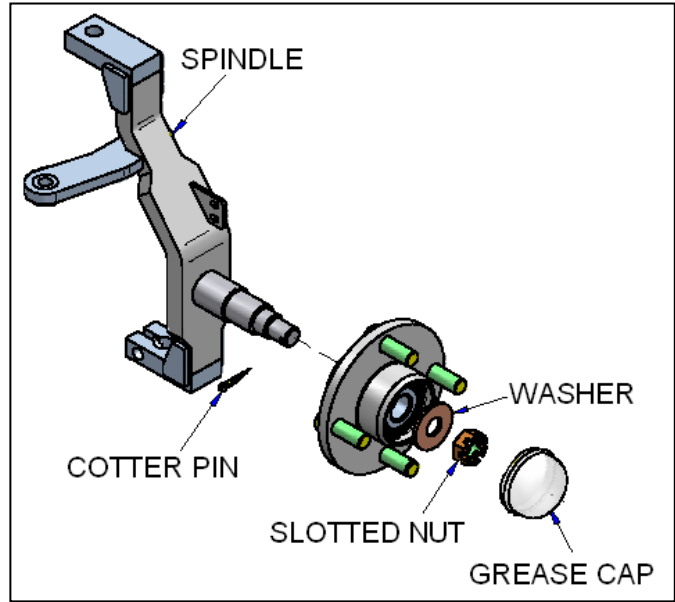
**Removing Front Wheels and Hubs**

1. Before raising vehicle, with wheels on the ground, break loose the lug nuts.

**WARNING**

**To perform this service, raise vehicle using floor jack and safely support it with jack stands positioned under main frame tubes. See Section 3 - Lifting Instructions.**

2. Remove lug nuts and wheel assembly from the hub.
3. Remove grease cap (Figure 6-1).
4. Remove cotter pin, axle nut and flat washer. Discard axle nut and cotter pin.
5. Carefully pull hub off the axle.
6. Repeat steps 1 - 5 for the other front wheel.



**Figure 6-1**

**Roller bearings**

Front wheel hubs have roller bearings. Bearings should be replaced whenever wheel hub is removed.

Pack bearings with lithium wheel bearing grease before installing.

**Installing Front Wheel Hubs and Wheels**

1. Clean spindle. Apply a thin coating of grease and install hub and bearing onto the spindle.
2. Install flat washer and new axle nut. Tighten axle nut to 50 ft. lbs. to seat bearing then loosen nut. Hand tighten nut until resistance is felt when turning the wheel hub, then back off until new cotter pin can be inserted.
3. Install grease cup.
4. Place wheel assembly on the hub studs.
5. Tighten four lug nuts by hand and wrench until snug using a crisscross pattern (See Section 5, Figure 5-3).
6. Lower the vehicle to the ground and torque the lug nuts to 65 ft. lbs. (23 Nm) using the same crisscrossing pattern.

Columbia / ParCar OEM Parts  
evtechnicalservices.com  
TECHNICAL SERVICES

**TIRES**

In the event of a flat tire, remove wheel assembly from vehicle and follow standard tire repair procedures.

**⚠WARNING**

Use care when inflating a tire with a high pressure air supply. Due to low pressure requirements of a small tire, over inflation may be reached in a matter of seconds. Over inflation could cause the tire to explode resulting in possible personal injury.

**STEERING WHEEL**

**Removing Steering Wheel**

1. Remove steering wheel cover by carefully prying out from steering wheel.

**NOTICE:** If the vehicle has a scorecard holder it will be necessary to first remove the three #10x1 screws that attaching the scorecard holder.

2. Remove two Phillips head screws securing steering wheel to collar (Figure 6-6).
3. Remove steering wheel nut from center of steering wheel.
4. Pull steering wheel from steering shaft.

**Installing Steering Wheel**

1. Make sure wheels are pointed straight ahead.
2. Apply Anti-Seize to steering shaft. Install steering wheel centered on splined shaft.
3. Install steering wheel nut and torque to 20 ft. lbs.
4. Connect collar to steering wheel with two Phillips head screws.
5. If equipped attach the scorecard holder.

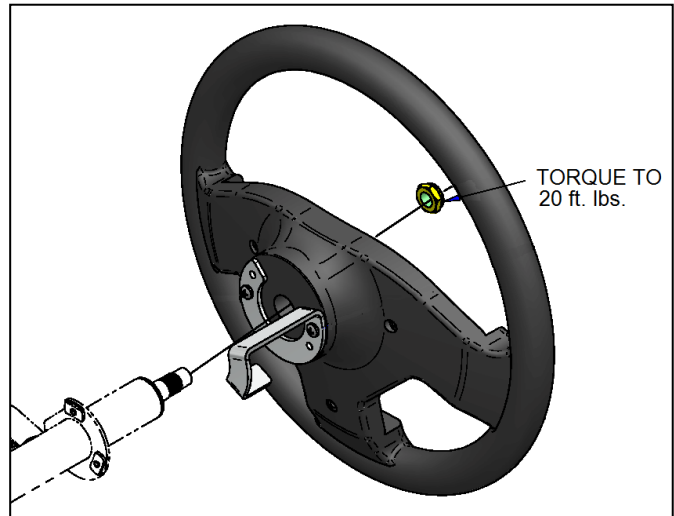


Figure 6-5

**RACK AND PINION STEERING ASSEMBLY**

**⚠WARNING**

To perform this service, raise vehicle using floor jack and safely support it with jack stands positioned under main frame tubes. See Section 3 - Lifting Instructions.

**Removing**

1. To access this assembly remove front wheels and the front lower fascia.
2. Remove steering shaft clamp bolt securing steering shaft to the steering rack (Figure 6-6A).

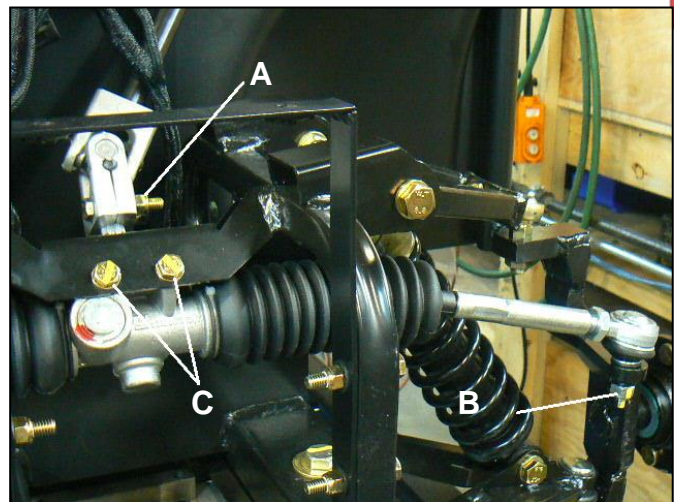


Figure 6-6



3. Remove nuts securing tie rod ends to left and right steering arm assemblies (Figure 6-6B). Lift tie rod ends from steering arms.
4. Remove two bolts securing rack steering assembly to frame (Figure 6-6C).
5. Remove assembly from vehicle.

**Installing**

1. Insert the assembly into the vehicle. Do not install mounting bolts (Figure 6-6C) at this time.
2. Insert steering shaft into steering rack and install clamp bolt (Figure 6-6A). Torque to 25 ft. lbs.
3. Install two mounting bolts through frame and into steering housing (Figure 6-6C) and secure with nuts. Torque to 20 ft. lbs.
4. Install tie rod ends to steering arm assemblies (Figure 6-6B). Install nuts and torque to 35 ft. lbs.

**FRONT SUSPENSION**

**⚠ WARNING**

To perform this service, raise vehicle using floor jack and safely support it with jack stands positioned under main frame tubes. See Section 3 - Lifting Instructions.

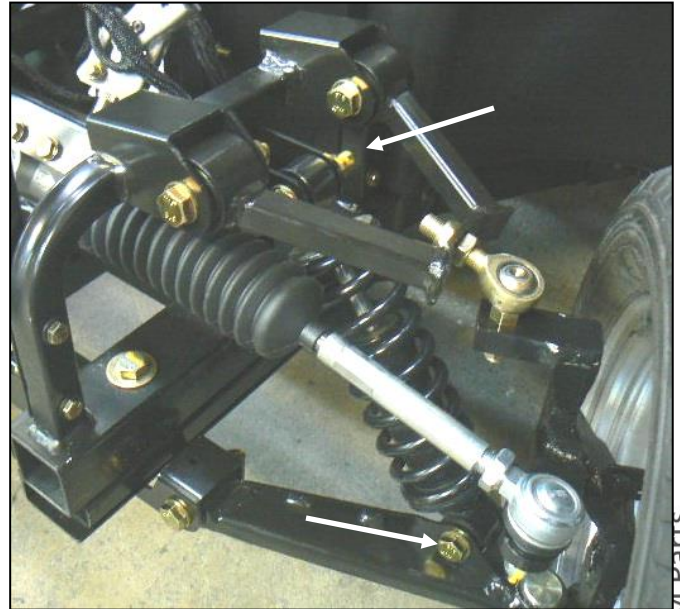
**Replacing Front Shock Coil Over**

Replace shock coil over if dampening effect is not present when shock absorber is collapsed or extended, or there are signs of oil leakage.

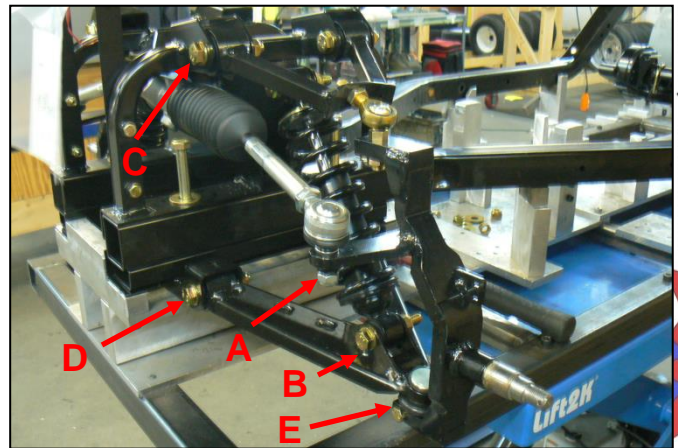
1. Remove wheel/tire assemblies.
2. Remove upper and lower mounting bolts, spacers and nuts securing shock coil over. See Figure 6-7
3. Install new assembly and secure with mounting bolts, spacers and new nylock nuts.
4. Torque to 55 ft. lbs.

**Disassembling Steering Spindles and A-Arms**

1. Remove front wheels and hubs as described in *Removing Front Wheels and Hubs*.
2. Remove tie rod end from steering spindle (Figure 6-8A).
3. Remove bolt and nut securing the lower shock coil over (Figure 6-8B).
4. Remove two bolts and nuts securing the upper A-Arm assembly (Figure 6-8c) to the upper suspension module.
5. Remove the two bolts and nuts securing the lower A-Arm assembly (Figure 6-8D).



**Figure 6-7**



**Figure 6-8**

6. Separate the lower A-Arm assembly from the steering spindle by loosening the securing bolt (Figure 6-8E).

**Assembling Steering Spindles and A-Arms**

1. Attach the lower A-Arm assembly to the steering spindle. Torque to 45 ft. lbs.
2. Secure the upper and lower A-Arm assemblies. Use new nylock nuts and torque to 55 ft. lbs.
3. Reattach the lower shock coil over (Figure 6-8B). Use new nylock nuts and torque to 55 ft. lbs.
4. Reattach the tie rod end to the steering spindle.



**STEERING ADJUSTMENTS**

To perform adjustments, place vehicle on flat, level surface. Position front wheels pointed directly forward.

**Camber Adjustment**

1. Place a carpenters square against left front wheel and check that wheel is straight up and down.
3. If wheel is not vertical, loosen the tie rod end assembly jam nuts (Fig. 6-9) and adjust until wheel is straight up and down.
4. When correct adjustment is obtained, tighten jam nuts.
5. Repeat for right front wheel.

**Toe in Adjustment**

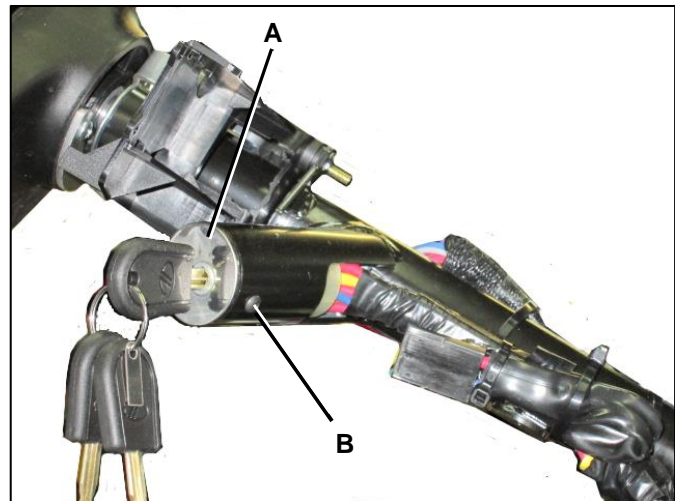
1. With wheels pointed directly forward, loosen jam nuts on tie rod ends.
2. Using a rod or stick approximately 27"-27½" long, check distance between front edge of both tires. Then check the distance between back edge of both tires.
3. The distance between tires at front edge should be ¼"-1/8" less than the distance between the back edge of the tires.
4. If distance between tires (toe in - toe out) is incorrect, rotate tie rods to adjust as necessary.
5. When correct distance is achieved, tighten tie rod jam nuts against tie rods.
6. Recheck measurements.

**KEYSWITCH REMOVAL**

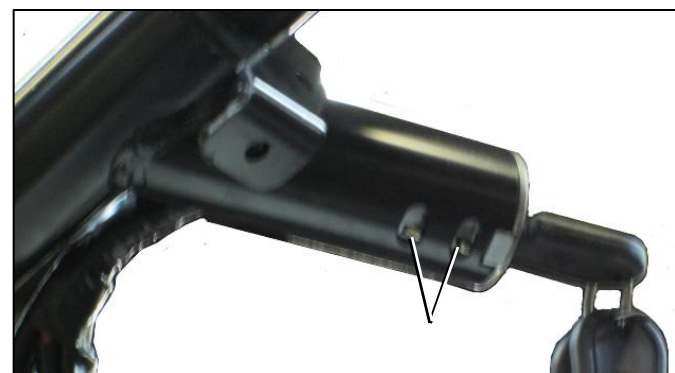
1. Remove the nine screws attaching the upper and lower column covers.
2. Use a 5/64" allen wrench to remove the column set screw (Figure 6-10B).
3. Remove the cable ties and electrical tape securing the keyswitch wires and unplug the connection.
4. See Figure 6-10A. Place the key switch in the unmarked arrow position.
5. See Figure 6-11. Use a flat blade screwdriver to push the two tangs inward while pulling the key switch out of the column.
6. Reverse the procedure to replace.



**Figure 6-9**



**Figure 6-10**



**Figure 6-11**



**Columbia ParCar Corp.**

**Service Manual**

**Section 7**

**Rear Wheels, Rear Suspension & Axle Assembly**



Columbia / ParCar OEM Parts  
[evtechnicalservices.com](http://evtechnicalservices.com)

**REAR WHEELS**

**⚠WARNING**

To perform this service, raise vehicle using floor jack and safely support it with jack stands positioned under main frame tubes. See Section 3 - Lifting Instructions.

**Removing Rear Wheels**

1. Before raising vehicle, with wheels on the ground, break loose the lug nuts.
2. Raise the vehicle and engage the brake. Remove four lug nuts and remove rear wheel/tire assembly
3. Repeat steps 1 - 2 for the other rear wheel.

**Rear Axle Wheel Bearings**

Rear axle wheel bearings are sealed type bearings and cannot be repacked. Bearings must be replaced if worn or damaged.

**Installing Rear Wheels**

1. Place wheel assembly on the hub studs.
2. Tighten four lug nuts by hand and wrench until snug using a criss-cross pattern.
3. Lower the vehicle to the ground and torque the lug nuts to 65 ft. lbs. (23 Nm) using the same criss-crossing pattern.

**TIRES**

See Section 6-Tires for tire removal, repair and mounting.

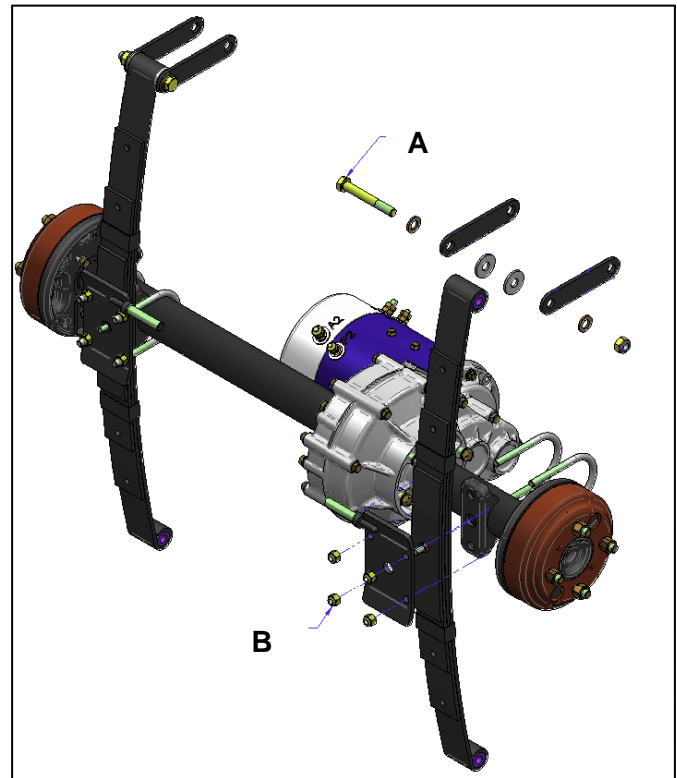
**REAR SUSPENSION**

**⚠WARNING**

To perform this service, raise vehicle using floor jack and safely support it with jack stands positioned under main frame tubes. See Section 3 - Lifting Instructions.

**Replacing Rear Leaf Springs**

1. With the vehicle on jack stands, use a hydraulic jack to support the rear axle.
2. Remove the bolts, washers and nuts securing the leaf spring to the chassis and the shackle plates (Figure 7-1A).
3. Remove the U-bolt nuts (Figure 7-2B) securing the spring plates.
4. Install new spring. Use new nylock nuts. Torque leaf spring and shackle plate nuts to 85 in, lbs. Torque U-Bolts nuts to 30 ft. lbs.



**Figure 7-1**

**Replacing Rear Shocks (If Equipped)**

1. Remove the top bolt and bottom nut securing the shock.
2. Remove and replace shock. Apply locktite to the top bolt and torque to 50 ft. lbs. Torque bottom nut to 50 ft. lbs.

**REAR AXLE ASSEMBLY**

**⚠WARNING**

To perform this service, raise vehicle using floor jack and safely support it with jack stands positioned under main frame tubes. See Section 3 - Lifting Instructions.

**Removing Rear Axle**

1. Before raising vehicle, with wheels on the ground, break loose the lug nuts.
2. Raise the vehicle and engage the brake.
3. Remove lug nuts and remove rear wheel/tire assemblies. Remove and discard cotter pin and axle nut. Release brake and remove spacer (if equipped) and rear brake drum. Repeat for other side.
4. Remove rear shock absorbers and springs as described previously.

5. Remove cotter pins, clevis pins and e-rings. Disconnect brake cables from brake assemblies on the rear axle.
6. Place a floor jack under the axle and lower axle.

**⚠ WARNING**

Rear axle is heavy and awkward to move. Get help lifting and removing axle to prevent possible personal injury.

**DISASSEMBLING REAR AXLE**

The rear axle is a precision assembly and any repair or replacement of parts must be done with great care in a clean environment. Before attempting to perform any axle service, read and understand all the procedures in this section.

- Handle all gears with extreme care.
- The axle assembly should be degreased prior to disassembly.
- Dirt is an abrasive and will cause premature wear of bearings and other parts. A small wash tank for cleaning parts should be close by when disassembling the axle assembly.
- Use soft, clean, lint-free towels to dry components before cleaning.
- Parts should be cleaned with emulsion cleaners or petroleum based cleaners.

**⚠ DANGER**

Do not use gasoline as a cleaner.

**NOTICE:** Bearings should not be dried by spinning with compressed air. This can damage mating surfaces due to lack of lubrication.

- After drying, parts should be lightly coated with SAE 30 weight oil to prevent corrosion damage. If parts are to be stored for a prolonged period of time, they should be wrapped in newspaper and plastic.
- Bearings, seals and O-rings should be replaced with new parts whenever they are removed. Always wipe seals and O-rings with SAE 30 oil before installing.
- Snap rings must be removed/installed with care to prevent damage to bearings, seals and bearing bores.
- Remove all residual gasket material from sealing surfaces.
- Use soft, clean, lint-free towels to dry components before cleaning.
- Parts should be cleaned with emulsion cleaners or petroleum based cleaners. Inspect all parts for signs of wear or damage and replace if necessary.







ITEM	DESCRIPTION
1	COVER CASE ASSEMBLY
2	GEAR CASE
3	CARRIER GEAR (See Item 45)
4	GEAR 15T (See Item 46)
5	GEAR 40T (See Item 46)
6	GEAR 18T (See Item 47)
7	BALL BEARING 6207 (See Item 45)
8	BALL BEARING 6303 (See Item 46)
9	BALL BEARING 6203 (See Item 47)
10	BALL BEARING 6205 (See Item 47)
11	SHIM 61X69X1.5t (See Item 45)
12	SHIM 36X44X1.5t (See Item 46)
13	SHIM 32X40X1.0t (See Item 47)
14	SHIM 45X51X1.5t (See Item 47)
15	WASHER 8.2X16X2.0t
16	WASHER 14.5X22X1.0t
17	SEAL 28X55X9h
18	SEAL 25X47X6h
19	BOLT M8XP1.25X100L
20	BOLT M8XP1.25X90L
21	BOLT M8XP1.25X12L
22	BOLT M14XP1.5X9.5L
23	NUT M8XP1.25
24	LOCATION PIN 8.2X10X12L
25	MACHINE KEY (See Item 46)
26	CIRCLIP – SHAFT 32 (See Item 46)
27	BREATHER TUBE
28	RING

ITEM	DESCRIPTION
29	GEAR BOX ASSY
30	SHAFT ASSY R
31	SHAFT ASSY L
32	TUBE ASSY R
33	TUBE ASSY L
34	DRUM
35	BOLT M10X1.25X35L
36	BOLT M8X1.25X25L
37	BOLT M8X1.25X28L
38	NUT SHRAPNEL M8XP1.25
39	NUT
40	BRAKE ASSEMBLY L
41	BRAKE ASSEMBLY R
42	SHOES, BRAKE
43	CABLE PLATE L
44	CABLE PLATE R
45	CARRIER GEAR ASSEMBLY 10.37:1 (Includes Items 3, 7 & 11)
46	INTERMEDIATE GEAR ASSEMBLY 10.37:1 (Includes Items 4, 5, 8, 12, 25 & 26)
47	INPUT GEAR ASSEMBLY 10.37:1 (Includes Items 6, 9, 10, 13 & 14)



**COLUMBIA** 

**Columbia ParCar Corp.**

**Service Manual**

**Section 8**

**Body & Chassis**

Columbia / ParCar OEM Parts  
**evtechnicalservices.com**



**FRONT BODY**

Removal of the front body is extensive. It requires removal of the cowl, dash panel, front lower fascia and the six screws attaching the body to the chassis. Under the hood disconnect all wiring and remove the four screws attaching the front body to the chassis.

**REPLACING FRONT HEADLIGHT/BULB**

1. Access to the bulb is from the hood compartment.
2. Disconnect the wires from the bulb and using a quarter turn remove the bulb and replace with a new bulb. See P5 Part Book for correct bulb.
3. To replace the light assembly, remove the three screw attach it to the front body.

**REPLACING REAR, STOP, TURN, & TAIL LIGHT/BULB**

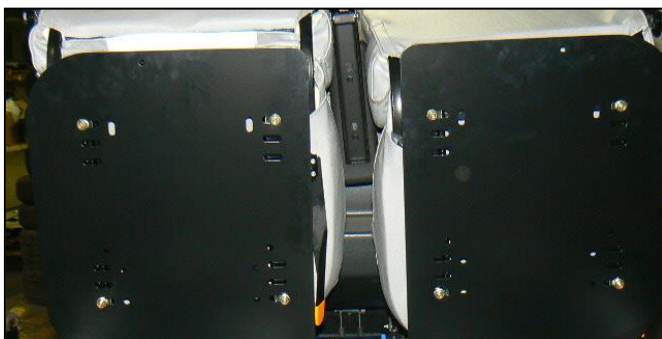
1. See Figure 8-1. Access the bulbs by remove the 6 screws attaching the tail light bezel to the rear body.
2. Disconnect the wires from the bulb and using a quarter turn remove the bulb and replace with a new bulb. See P5 Part Book for correct bulb.
3. To replace any of the light assemblies, disconnect the wires. The assemblies have been glued to the bracket (See Fig. 8-2) with seal bond in two locations. It will be necessary to scrape away the seal bond. Once removed depress the two silver tabs.

**REPLACING FRONT TURN SIGNAL/BULB**

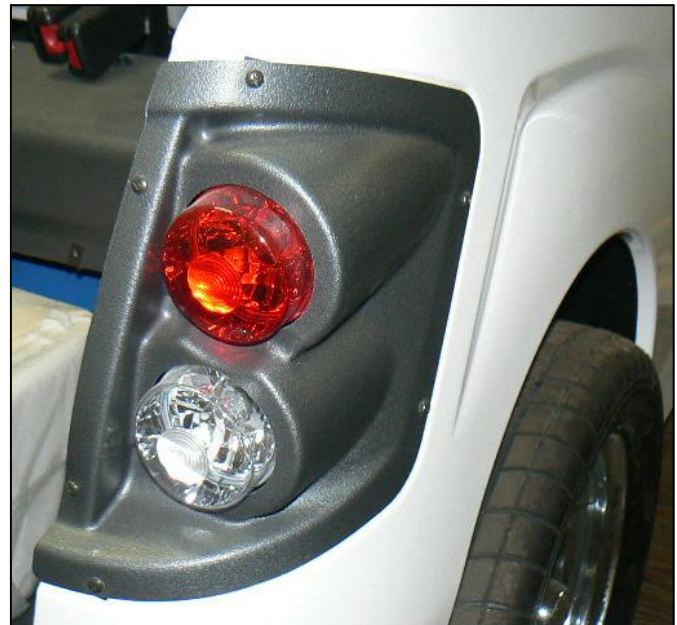
1. Access to the bulb is from underneath,
2. Disconnect the wires from the bulb and using a quarter turn remove the bulb and replace with a new bulb. See P5 Part Book for correct bulb.
3. To replace the light assembly, follow the same procedure noted above (Item 3) for replacing Stop, Turn & Tail Lights.

**SEAT REMOVAL**

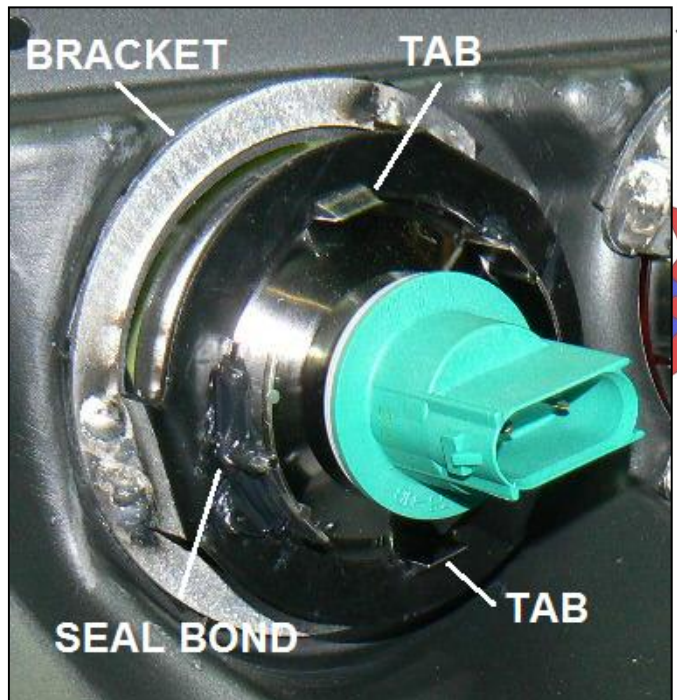
1. See Figure 8-3. Lift the seat exposing the seat base.
2. Each seat is attached to the seat base with 4 nuts and washers.



**Figure 8-3**



**Figure 8-1**



**Figure 8-2**

**NOTICE:** The brackets are secured with double-faced tape. If the decision is to replace the bracket and the light assembly, scrape clean the body/bezel surface, retreat with alcohol and primer before securing with double-face tape.

Columbia / ParCar OEM Parts  
evtechnicalservices.com  
TECHNICAL SERVICES

**REAR/MID BODY REMOVAL**

1. See figure 8-4.
2. Remove the tail light assemblies as describes in page 8-1 and disconnect the wires.
3. Remove the twelve screws attaching the rear body.

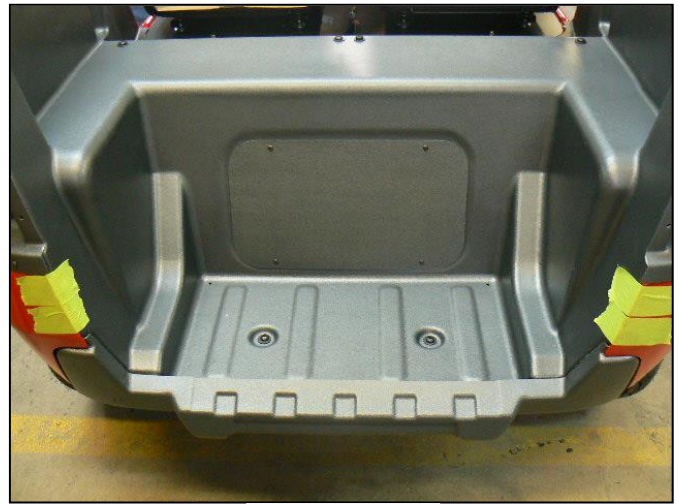
**NOTICE: If equipped, seat belt attachments and sun top supports may be attached with these screws and will require removal.**

**CONSOLE CONTROLS**

1. See Figure 8-4. To access/replace the hour meter, system status light or the battery discharge indicator remove the 4 screws holding the gage panel in place.
2. To access/replace the horn/turn signal/light switch, hazard switch or the ignition switch remove the screws attaching the upper and lower column covers.

**DIRECTIONAL SWITCH REMOVAL**

1. See Figure 8-6.
2. Use an allen wrench to remove the knob. See arrow.
3. Under the knob is a 9/16 securing nut. When removed the control unit will drop down.



**Figure 8-4**



**Figure 8-5**



**Figure 8-5**

Columbia / ParCar OEM Parts  
 evtechnicalservices.com  
 TECHNICAL SERVICES



**FUSE BLOCK - 12V ELECTRICAL**

1. See Figure 8-7. A fuse block protecting the 12V electrical circuits of the vehicle is located under the hood.
2. The fuse block has a snap off cover for access to the fuses.

**HORN**

1. See Figure 8-7. The horn is located under the hood.
2. Disconnect wires. Remove the screw/nut securing it to panel.

**BRAKE LAMP CONTROL**

1. See Figure 8-7. Located under the hood.
2. Disconnect wires. Remove the screw/nut securing it to panel.

**DC DC CONVERTER**

1. See Figure 8-7. Located under the hood.
2. Disconnect wires. Remove the screws/nuts securing it to panel.

**FUSE BLOCK - 48V ELECTRICAL**

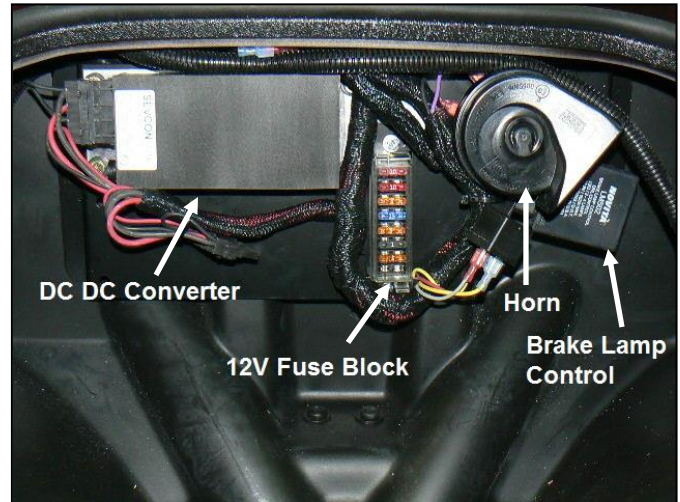
1. See Figure 8-8A A fuse block protecting the 48V electrical circuits (horn, BDI, etc.) of the vehicle is located beneath an access panel under the front seats.
2. The fuse block has a snap off cover for access to the fuses.

**CONTROLLER**

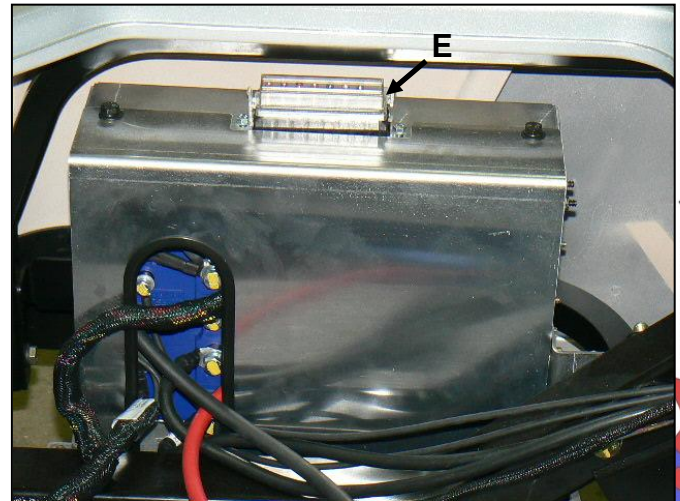
1. See Figure 8-8. Located beneath an access panel under the front seats. It is covered with a metal box. The two top screws will allow removal of the front panel to get access to the wires.
2. The controller box is secured with 2 bottom screws and one screw on the left side. To remove, label and undo wires then remove the securing screws.

**CHARGER, RECEPTACLE & REMOTE LED**

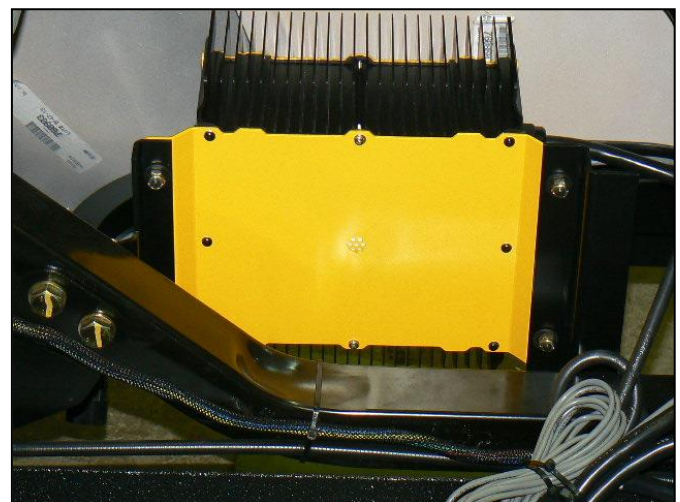
1. The charger receptacle (not shown) is located on the left side of the vehicle near the driver's position. The AC cord is plugged in here for battery charging. See SECTION 9 BATTERY AND CHARGER for more information on this LED.
2. See Figure 8-9. The charger is located beneath an access panel under the front seats on the left side of the vehicle. It is secured with 4 screw and nuts.



**Figure 8-7**



**Figure 8-8**



**Figure 8-9**

**COLUMBIA** 

**Columbia ParCar Corp.**

**Service Manual**

**Section 9**

**Battery & Battery Charger**



**IMPORTANT INFORMATION**

The type of battery used in a Columbia vehicle has a service requirement which is quite different from that of an automotive battery.

The electric vehicle battery supplies all of the power to drive the vehicle. During operation the power stored in the batteries is expended. While the amperage drain rate can vary greatly depending on the type of service, the duration of use and the number of “starts” and “stops” made during a day, the batteries nevertheless progress through each duty cycle from “fully charged” to an almost depleted state. This type of service is known as “deep cycle” service and electric vehicle batteries are specifically designed to handle this type of service.

Proper performance of your Columbia Vehicle can only be obtained from specified deep cycle, electric vehicle batteries.

**SAFETY INFORMATION**

**▲ DANGER**

**All batteries used in electric vehicles can explode! Always wear full face shield when working on or near batteries. Hydrogen fumes are a natural byproduct of charging and discharging and are extremely explosive.**

**Do not smoke around electric vehicle batteries. Keep sparks and flames away from batteries. Battery charging should only be done in a well-ventilated area. Refer to Section 9-Batteries for details.**

**Batteries contain acid which can cause severe burns. Avoid contact with skin, eyes, or clothing. Wear full face shield and rubber gloves when working on or near batteries.**

**Do not attempt to charge a battery if it is frozen or if the case is bulged excessively. Frozen batteries can explode. Dispose of battery.**

**▲ WARNING**

**When working around batteries, use approved insulated tools, remove jewelry such as rings, watches, chains, etc. and place an insulating material such as wood, plastic, rubber, etc. over batteries covering all connections.**

**If any problems are found during scheduled maintenance or inspections, do not operate vehicle until repairs are completed. Failure to make necessary repairs could result in fire, property damage, severe personal injury or death.**

**NOTICE: Automotive batteries should never be used for “deep cycle” application, as their useful life will be very short.**

**Install surge arrestors on incoming AC power lines. Surge arrestors will help protect electrical/electronic components in the charger and vehicle from all but direct or “close proximity” lightning strikes.**

**Antidotes**

- **External: Flush with water. Call a physician immediately.**
- **Internal: Drink large quantities of milk or water. Follow with milk of magnesia or vegetable oil.**
- **Eyes: Flush with water for fifteen minutes. Call a physician immediately.**

**BATTERY INSPECTION & MAINTENANCE**

Batteries and connections must be clean and dry. See *BATTERY CLEANING*.

Be sure battery hold downs are properly tightened. A loose hold down may allow the battery to become damaged from vibration or jarring. A hold down that is too tight may buckle or crack the battery case.

Weekly inspect battery posts, clamps and cables for breakage, loose connections and corrosion. Replace any that are damaged.

Check to see that battery cap vent holes are clear. Plugged vent holes will not permit gas to escape from the cell and could result in battery damage.

**BATTERY CLEANING**

Battery terminal connections should be individually cleaned and maintained annually. More frequent cleaning may be required under heavy use, or as batteries age.

**NOTICE: Make note of any accessory wire connections before disconnecting batteries. Refer to wiring diagrams for proper connection.**

1. Remove battery cables and wire connections from all battery terminals.
2. Brush battery cable and wire connections clean using soft brass wire brush.
3. Replace battery cable terminals that are damaged or corroded.
4. Keep the batteries clean, fully charged, properly secured and terminal connections tight. Do not over tighten connections. Acid soaked dirt on the battery tops causes current leakage, reduced battery efficiency and promotes rapid self-discharge during storage.
5. Hose wash battery tops periodically with clean, low-pressure water to keep them free of acid spillage, dirt and other debris. If vented batteries are used, make sure vent caps are secure before washing. Do not hose wash electronic controllers, switches, solenoids, and other electrical control devices. Direct water away from these components. Cover if necessary.



6. Wash battery tops with a baking soda mixture (1/2 cup per quart of water) and a stiff non-metallic bristle brush if a low-pressure hose does not remove the dirt. Rinse with clean water. Take care to ensure that the baking soda mixture does not enter the vent opening in the battery caps.
7. Make sure that the battery tops are clean and dry before putting the batteries into storage.

**BATTERY SERVICE (WATER)**

The operating environment of the electric vehicle could vary widely. Severe service operations will require that periodic maintenance recommendations be adjusted to shorter time intervals.

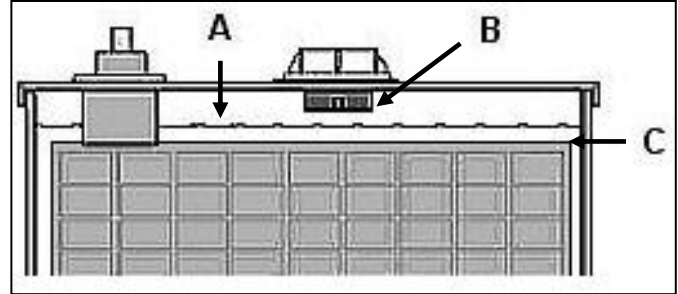
Use only distilled water in your batteries. Vehicle batteries may use up to 16 quarts of water during their useful life and non-distilled water may contain harmful minerals which will have a cumulative adverse effect on battery performance and life.

Watering intervals are dependent on the local climate, charging methods, application, and age of batteries. After the initial watering of new batteries, it is recommended that batteries be checked once a month until you get a feel for your water consumption rate.

Typically for a heavy use application, recommend watering is maximum of once per week, and for light use applications once per month

**Adding Water** (See Figure 9-1)

- Check the electrolyte level on brand new batteries before putting them into service, and at least weekly on batteries in service. Water use increases as batteries age.
- Never allow the electrolyte level to fall below the top of the plates (A). If the plates are exposed, add only enough distilled water to cover the plates before charging.
- Do not overfill batteries. Do not fill the water level up into the well of the filler tube of the cell. Electrolyte expands and can overflow during charging (B). Water added to replace the spillage dilutes the electrolyte and reduces its specific gravity. Cells with lower specific gravity have lower charging capacity.
- Make sure the electrolyte covers the plates before charging (C). Fill cells to the markers only after batteries are charged.

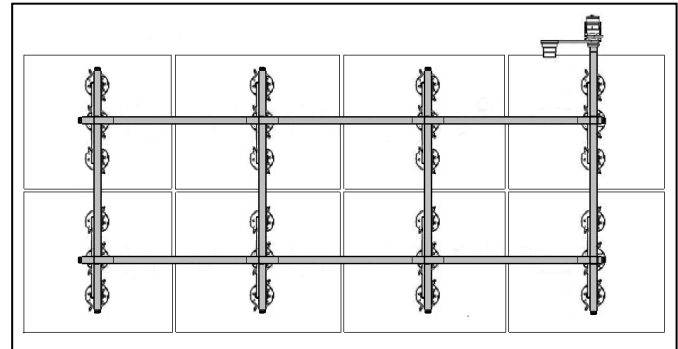


**Figure 9-1**

**SINGLE POINT WATERING SYSTEM**

**NOTICE: The following information does not apply to sealed batteries.**

P5 vehicles have a Single Point Watering System (Figure 9-2) used for adding water to the battery pack. It consists of a fill tube, one end having a filter screen, the other having a female coupler and a rubber squeeze bulb.



**Figure 9-2**

**NOTICE: To avoid overfilling of the Single Point Watering System do not operate this system on brand new batteries. New batteries should be in service 1 to 2 weeks with heavy use or 3 to 4 weeks with light use. System is to be used only after fully charging the batteries and batteries are warm.**

When using this system, check the battery pack water level weekly by:

- Inserting the fill tube filter end in a distilled water supply.
- Attaching the female coupler to the battery pack male coupler.
- Squeeze the rubber ball until firm which indicates that filling is complete. Immediately disconnect the couplers by depressing the push button on the female coupler. If the water supply is left connected after the filling process is finished it could lead to an overflow.

US Batteries features SpeedCap™ battery cell caps. See Figure 9-3. To open SpeedCap™ locate the two tabs on either side of the center cell of the battery. Move these tabs in the directions shown in Figure 9-3.



Figure 9-3

**NOTICE:** Do not use SpeedCaps™ as handles to lift or move battery.

**BATTERY CHARGING**

**▲ DANGER**

Observe all safety information in this section, safety information listed at the beginning of this section, and safety information in *Section 1* of this manual.

Columbia electric vehicles are equipped with a solid state, onboard, fully automatic, Delta-Q Battery Charger as standard equipment. See Figure 9-3.

It is important to be aware of the differences and improvements over prior chargers, which are explained in the Delta-Q Charger Operating Instructions that accompany every vehicle.

Correct charging methods extend battery life and vehicle range between charges. Before the first new vehicle use, completely charge new batteries. Charging time is affected by age of battery, condition of battery, state of discharge, temperature of electrolyte, AC line voltage level, and other variables. Charging time usually takes 12 hours. New batteries need up to four hours more charging time than “mature” batteries.

Always schedule enough charging time so that the charger completes a full charge cycle. Opportunity charging is an acceptable practice for use during a shift to extend the range, but always allow for a full charge cycle at end of shift.

Limit the use of new batteries between charges for the first 15 – 20 cycles. New batteries have less capacity than batteries which have been cycled.

Recharge batteries immediately after use. Leaving batteries in a state of discharge will reduce their capacity and useful life. Battery chargers are voltage specific; 24, 36 or 48 volts. However, chargers can be programmed at the factory for different types of batteries, as well as different brands and capacities of batteries. Refer to Battery Brand Algorithms for Charger Programming, See Table 1.

The lead-acid storage battery supplies electrical power through the chemical action. This action is reversible, which means the battery must be connected to a charger and have an electrical current passed through it in the direction opposite to the direction of discharge in order to restore the battery's active chemicals.

The Delta-Q Charger will not over charge batteries if left plugged in.

**Charger Safety Information**

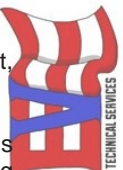
**▲ WARNING**

Do not attempt to charge a battery if it is frozen or if the case is bulged excessively. Frozen batteries can explode. Dispose of battery.

- Charge batteries in well ventilated area.
- Ventilation fans should be located at the highest point in charging area. These fans should be able to exchange the air 5x per hour. Consult a local HVAC engineer.
- Remove rings and watches prior to service. Only trained technicians should repair or service the charger. Contact Columbia for assistance.
- Replace worn, cut or damaged power cords or wires.
- Do not connect the power cord near fuels, grain dust, solvents, thinners, or other flammables.
- Install surge arrestors on incoming AC power lines. This protects from all but direct or close proximity lightning strikes.
- Do not cover charger cabinet cooling fins. This protects the charger from overheating.
- Make sure all battery and charger connections are clean and tight. This prevents overheating and arcing at the terminal. Replace as necessary.
- Disconnect negative (-) cable first to avoid crossing terminals that would create a spark.

**NOTICE:** When using ordinary automotive chargers, there is the possibility of overcharging and damaging the cells.

Columbia / ParCar OEM Parts  
evtechnicalservices.com



**BATTERY BRAND ALGORITHMS**

ALGORITHM ID	ALGORITHM DESCRIPTION	AMP HOUR	TYPE	DESIGNED FOR	COMPATIBLE WITH
1	Trojan Flooded	225	Flooded	Trojan T105	150 - 260Ah 6V, 8V, 12V flooded golf
3	Trojan Constant Power dv/dt	225	Flooded	Trojan T105	150 - 260Ah 6V, 8V, 12V flooded golf
5	Trojan Group 31 Flooded	130	Flooded	Trojan 30XHS, 31XHS	85 - 150Ah 12V flooded "marine" Exide Orbital AGMs, Optima AGMs
6	Deka 8G31 Gel	100	Gel	Deka 8G31	Deka 98 - 120Ah gel
7	Trojan 305 Constant Power dv/dt	305	Flooded	Trojan L16	Trojan J305
8	Concorde 100Ah AGM	100	AGM	Concorde 104Ah AGM	Concorde 80-150Ah AGM
11	200 - 255Ah Flooded Constant Power dv/dt	230	Flooded	US Battery US125 & 225	200 - 255Ah flooded golf
12	Exide Gel	240	Gel	Exide DF06240	200 - 300Ah gel
21	Exide Flooded	210	Flooded	Exide 3ET200, FF06255, 185PZB210	Exide200 Ah – 300 Ah Flooded
26	Deka 8GGC2 Gel	180	Gel	Deka 8GGC2	Deka 150 - 230Ah gel
35	Concorde 200Ah AGM	200	AGM	Concorde 233Ah AGM	Concorde 200 - 255Ah AGM
38	Trojan 12V Golf 113%	150	Flooded	Trojan T1275	120 - 170Ah 8V, 12V flooded golf
42	Discover 80 - 150Ah AGM	100	AGM	Discover EV31A	other 80 - 150Ah AGM
43	Discover 200 - 400Ah AGM	300	AGM	Discover EVL16A, EVGC6A, EV185A	Discovery 200 Ah – 400 Ah AGM
51	Exide 180Ah Gel	180	Gel	Sonnenschein 180Ah Gel	150 - 200Ah gel
52	Exide 105Ah Gel	105	Gel	Sonnenschein 105Ah Gel	80 - 130Ah gel
62	Trojan Group 31 Flooded dv/dt	130	Flooded	Trojan 30XHS, 31XHS	85 - 150Ah 12V flooded "marine"
71	140 - 200Ah Flooded Constant Power dv/dt	170	Flooded	US Battery 8V-GC	140 - 200Ah Flooded
72	250 - 335Ah Flooded Constant Power dv/dt	305	Flooded	US Battery US-305HC	250 - 320Ah Flooded
73	400Ah Flooded Constant Power dv/dt	415	Flooded	US Battery L-16HC	330 - 425Ah Flooded
93	Trojan 12V Golf	150	Flooded	Trojan T1275	120 - 170Ah 8V, 12V flooded golf
125	Fullriver 160-220Ah AGM	180	AGM	Fullriver DC180-6, DC224-6	Fullriver 160 - 220Ah AGM
126	Fullriver 85-145Ah AGM	110	AGM	Fullriver DC115-12	Fullriver 85 - 145Ah AGM
141	Fullriver 300-370Ah AGM	335	AGM	Fullriver DC335-6	Fullriver 300 - 370Ah AGM
151	Fullriver 220-290Ah AGM	250	AGM	Fullriver DC250-6	Fullriver 220 - 290Ah AGM

Columbia / ParCar OEM Parts  
evtechnicalservices.com  
TECHNICAL SERVICES

**Table 1**

**NOTICE:** Charger are factory preloaded with algorithms 1, 3, 5, 6, 7, 8, 11 (Default), 27, 43, and 73.



**DELTA-Q CHARGER OPERATION**

Vehicles are equipped with a remote panel (Fig. 9-4A) with a single LED which indicates the Delta Q status. The remote panel will be located near the driver’s position. See SINGLE LED DISPLAY.

Connect power cord at charger receptacle to properly grounded wall outlet.

**NOTICE: Connect the charger AC cord to a source capable of supplying 15 amperes minimum per charge (20 amperes recommended). The charger is equipped with an equipment-grounding AC electric cord, and a grounding type plug.**

Connect the cord to an appropriately installed receptacle grounded in accordance with the National Electric Code ANSI/NFPA 70, and all local codes and ordinances.

**SINGLE LED DISPLAY (Figure 9-4A)**

SOLID GREEN – Charging complete, in maintenance mode

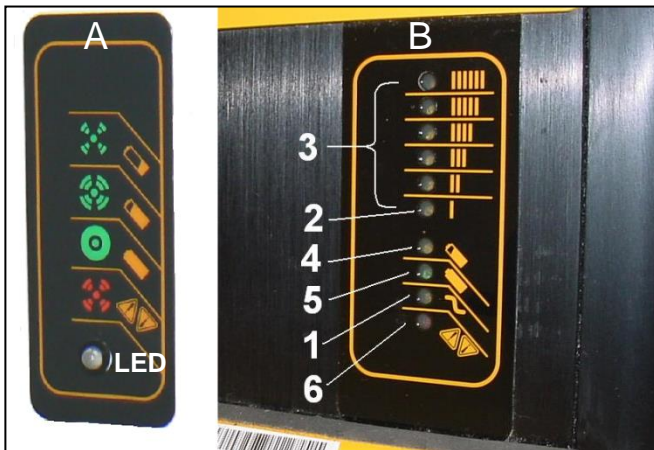
FLASHING GREEN – Short < 80% charge

Long > 80% charge

GREEN when battery not connected – Algorithm number

FLASHING YELLOW – Reduced power mode: low AC voltage or high internal charger temperature.

LASHING RED – Charger error. Reset charger power and see RED LIGHT CHARGER ERROR CODES.



**Figure 9-4**

**DELTA-Q DISPLAY (Figure 9-4B)**

1. The Yellow AC power LED (No. 1, Fig. 9-4B) should remain illuminated while the Charger is plugged into an AC source. If Yellow LED is not lit, before replacing Charger, recheck the AC connection and the AC source fuse or breaker. If this fails to correct the problem, contact your Columbia Dealer for assistance.

2. Charger will automatically turn on and conduct a short self-test and battery pack test. All LED’s will flash in sequence and then a trickle current will be applied to batteries until a minimum voltage is reached. In Figure 9-4B No. 3 indicates the Bar Graph and No. 2 indicates the lowest LED. Three (3) amperes is displayed as the lowest LED on the Bar Graph

3. If the batteries meet the minimum voltage requirements of the Charger, signifying they are serviceable (chargeable), the Charger enters the bulk charging (higher amperage-constant current) stage. The Bar Graph LED’s indicate the electrical current being delivered to the batteries as the Charger moves through its automatic charge profile. The length of charge time at each level will vary due to battery size and battery charge depletion.

**NOTICE: If the batteries are excessively discharged, the Delta-Q will not be able to charge the complete set of batteries. The Delta-Q will have the RED FAULT LED (No. 6, Fig. 9-4B) flashing red (see RED LIGHT CHARGER ERROR CODES). It will then be necessary to follow the instructions in EXCESSIVELY DISCHARGED BATTERIES.**

4. When the Yellow LED (No. 4, Fig 9-4B) is lit, the Charger has completed the bulk stage and the batteries are at approximately 80% state of charge. The 80% LED remains on as the last 20% of charge is returned to the batteries in the second phase (constant voltage phase).

**NOTICE: You can terminate charging at this point if necessary. The vehicle can be used, but completing the charge cycle is highly recommended.**

5. Charge completion is when the 100% Green LED is lit (No. 5, Fig. 9-4B). Repeated “Short Charging” leaving the charge short of 100% will shorten operating cycle distance and reduced battery life.

6. A low current “finish-charge” phase returns and maintains batteries to maximum capacity. The 100% Green LED will blink until “finish charge” phase is complete.

7. A 100% Green LED continuously lit indicates the batteries are completely charged. The Charger may now be unplugged from the AC source. If the batteries will not be used for a length of time, check monthly for the charge level. It is also acceptable to leave the Charger plugged in. The Delta-Q has the capability to test and recharge if necessary.

8. A fault occurring while charging causes the RED FAULT LED to flash with a code relaying the error. Some errors may require repair by a qualified technician and others may be simply transient and will automatically recover when the fault condition is eliminated and the Delta-Q cycled by disconnecting the AC source for a minimum of 11 seconds.

Columbia / ParCar OEM Parts  
evtechnicalservices.com  
TECHNICAL SERVICES



**NOTICE: A Yellow (Amber) blinking LED in the upper Bar Graph (No. 3, Fig. 9-4B) usually indicates the thermostatic control has limited the Charger output due to ambient temperature conditions. It is still charging, but at a reduced rate.**

**NOTICE: Do not disassemble the charger. There are no serviceable parts.**

**RED LIGHT CHARGER ERROR CODES**

**1 Flash**

Battery Voltage High: Auto-recover. May be temporary condition, or wrong charger installed, i.e. 36 volt charger on 48 volt battery pack.

**2 Flash**

Battery Voltage Low: Auto-recover. Confirm each individual batteries minimum voltage with a volt meter. Two or more 6 volt batteries register less than 5.85 volts, or accumulative total pack voltage has been discharged to less than 20% remaining. Vehicle operation will cease until batteries are recharged. See Special Procedure for Excessively Discharged Batteries in this section.

**3 Flash**

Charge Timeout: The charging did not complete in allowed time, 12-14 hours. This may indicate a battery problem, or that the charger output was reduced due to high ambient temperatures. Disconnect AC supply, confirm sufficient ventilation, allow cool down time, and restart charger.

**4 Flash**

Check Battery: The batteries could not be trickle charged up to a minimum level to start charger. This may be the result of badly discharged batteries, or one (or more) damaged cells. See Special Procedure in this section.

**5 Flash**

Over-Temperature: The charger shut down due to high internal temperature. May require reset (AC unplugged) and a cool down to restart charging cycle. This fault may indicate inadequate cooling airflow or high ambient air temperatures. Check for debris or blockage at cooling fins. Move the vehicle to a cooler better ventilated area, or adjust time of day when charging.

**6 Flash**

Delta-Q Charger Fault: An internal fault was detected and charger may need to be checked/replaced by a qualified dealer technician. It may also be the result of badly discharged batteries, or one (or more) damaged cells. A RED 6 FAULT flash must be validated first by testing individual batteries with a voltmeter, and see Special Procedures, before deciding charger has failed.

**A Steady Red Fault LED**

Confirms an internal electrical fault of the Delta-Q and also requires charger replacement and return.

**PRO CHARGER OPERATION**

When your battery charging system is activated, the battery status indicator (Figure 9-4) provides charging information utilizing five red LED indicators and one green LED indicator.

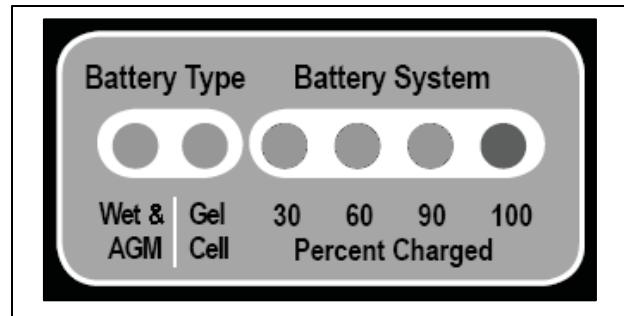


Figure 9-4

**Battery Type Indicators**

Two amber LED indicators are provided in order to display what type of battery the charger has been programmed to charge.

**NOTICE: For information on reconfiguring the battery type, please contact ParCar technical support.**

**Battery System Percent Charged Indicators**

Four LED indicators are provided in order to display the progress of the charge cycle in percentage of charge

Indications are as follows:

**1ST AMBER LED** - Illuminated configured for Wet Cell and AGM batteries

**2ND AMBER LED** - Illuminated configured for Gel Cell batteries

**1ST RED LED** - Charging - Initial Charging Up To 30%

**2ND & 3RD RED LEDS** - Charging - 60% Complete

**1ST, 2ND & 3RD RED LEDS** - Charging - 90% Complete

**BLINKING GREEN LED** - Finishing Stage (Note: Battery Type Indicator will also blink during this stage)

**STEADY GREEN LED** - Charge Complete. Maintenance Mode-On for 5 min. and off for 60 min.

The green LED is illuminated whenever the charge cycle has terminated and the internal circuitry has determined the batteries to be fully charged. The green LED will blink during the finishing stage of the charge cycle. After the completion of the charge cycle, the green LED will remain on steady during the float-maintenance stage.

During this final stage current is only flowing to the battery system for 5 minutes and then current will stop completely for 60 minutes. Your system provides an equalization stage every 30 days while plugged in. If the charger is normally disconnected from A/C after completing charge, equalization can be accomplished by plugging back into A/C whenever this stage is desired.

Columbia / ParCar OEM Parts  
evtechnicalservices.com



Battery manufacturers recommend that equalization is done once a month in order to further reduce sulfation on the lead plates of a battery, which helps promote longer battery life.

**NOTICE:** : During this process the LEDs will go through their normal routine (Red LEDs counting up for % of charge along with the illuminated Red LED Battery Type and then the Green LED and Red Battery Type LED will blink) until the unit returns to the maintenance mode and a steady Green LED and steady Red Battery Type LED. (Not applicable to Gel Profile).

**TROUBLESHOOTING**

**PROBLEM:**

**No LED indicators illuminated on battery status indicator.**

Solution Sequence:

1. Confirm that current is being delivered to the charger. Use a meter or test light to check the AC power supply from its source through all connecting points up to the charger.
2. Check that the AC circuit breaker (on front of the unit) is depressed.
3. Call ParCar technical support for further assistance.

**PROBLEM:**

**The charge status indicator changes rapidly back and forth from red to green or the green LED will not illuminate after excessive charging time (24 hours or more).**

Solution Sequence:

1. Disconnect AC power from the charging system. This indication may signify a possible battery problem.
2. Call ParCar technical support for further assistance.

**PROBLEM:**

**A green LED was illuminated before disconnecting the power from the charger, but upon reconnection, red LEDs appear and remain on.**

This is the normal operating procedure for the system. It indicates that a reanalysis of the battery status was initiated and after a series of steps the green LED will illuminate.

**LIGHT EMITTING DIODES (LED)  
FAULT CODE INDICATIONS**

The microprocessor is constantly monitoring the charger circuitry and will both detect and display blinking LED indications if a fault is detected. The battery type LED will be **OFF** during a fault code condition.

**30% RED LED BLINKING - NO BATTERY DETECTED**

This indication occurs whenever the charger circuitry cannot detect a battery. The charger circuitry will not allow charge current to flow under this condition. With the AC power supply cord unplugged, check the connection to the batteries for proper polarity (black wire to negative or -). Also check for corrosion free secure connections to the battery.

**30 & 60% RED LEDS BLINKING - FORMING STAGE TIMEOUT SHUTDOWN**

This indication occurs if the battery voltage has not risen above 1.75 volts per cell within the first 3 hours of charging. This indicates that a possible battery problem exists and that the charge cycle has been terminated at this point.

**30, 60 & 90% RED LEDS BLINKING.- OVERALL TIMER SHUTDOWN**

This indication occurs if the charger has not completed the charge cycle within the allowable factory set time period. This indicates that a possible battery problem exists and that the charge cycle has been terminated at this point.

**30 & 90% RED LEDS BLINKING  
.....INTERNAL OVERTEMP  
SHUTDOWN**

This indication occurs if the charger circuitry has detected operating temperatures inside the charger enclosure that are above factory specified levels. This could indicate that a possible charger problem exists and that the charge cycle has been terminated.

**30% RED & 100% GREEN LEDS BLINKING  
..... BULK STAGE SHUTDOWN**

This indication occurs if the battery voltage does not rise properly during the Bulk Stage. This indicates that a possible battery problem exists and that the charge cycle has been terminated at this point. Please call ParCar technical support for further assistance.

**NOTICE: Disconnecting and reconnecting the AC power supply cord will reset the charger.**



**CHARGING PROCEDURE**

1. Check electrolyte level in all cells. Add distilled water as necessary to cover tops of plates. Do not over fill, as electrolyte expands during charging.
2. Be sure charger is turned OFF. Insert electrical plug into vehicle's charger receptacle.
3. Charger will start automatically. Check that amp meter rises fully when charger starts. If charger needle only rises to half scale or does not rise at all, check AC outlet for proper power supply or check with ParCar Tech Service.

**TESTING BATTERIES**

**Specific Gravity Test**

**NOTICE: Specific Gravity Test information does not apply to sealed batteries.**

It is possible to determine a battery's ability to perform by measuring the specific gravity of each cell with a hydrometer. The hydrometer readings indicate two things:

- State of Charge - The amount of electrical power stored in the battery.
- Condition - The ability of battery to store and deliver power.

**NOTICE: Batteries should be fully charged before performing specific gravity tests to determine battery condition. Hydrometer tests of batteries not fully charged are misleading and inconclusive.**

**Hydrometer Test**

1. Squeeze rubber bulb and insert nozzle in cell, release bulb, slowly drawing electrolyte up into barrel.
2. Adjust electrolyte level in barrel so float rides free of bottom but is not striking top of barrel.
3. Hold hydrometer vertically, making sure float moves freely and is not contacting sides of barrel. Read scale at the level of electrolyte in the barrel. Record the reading.
4. Return electrolyte to cell from which it was removed.
5. Repeat these steps on all battery cells.

Hydrometer readings are affected by the temperature of the electrolyte being tested. Measure the temperature of the electrolyte, and correct the readings as follows:

**Above 80°F:** Add .004 to the specific gravity readings for each 10° above 80°F (26°C).

**Below 80°F:** Subtract .004 from the specific gravity readings for each 10° below 80°F (26°C).

**Results Interpretation**

State of charge. Check specific gravity of each cell. See Table 2 & 3.

Specific Gravity vs. State of Charge	
SG Reading at 80° F.	State of Charge
1.250 – 1.270	100%
1.220 – 1.240	75%
1.190 – 1.210	50%
1.160 – 1.180	25%

Table 2

Specific Gravity vs. Action Required				
Battery	SG Reading			Action
	Cell 1	Cell 2	Cell 3	
1	1.100	1.100	1.100	Charge & recheck
2	1.260	1.180	1.250	Cell 2 bad – replace battery
3	1.250	1.260	1.250	Good
4	1.190	1.170	1.120	Charge & recheck Suspect cell 3

Table 3

If the difference between the highest and lowest cell is 0.050 (50 points) or more, the battery is nearing the end of its useful life and should be replaced.

**DISCHARGE (LOAD) TEST**

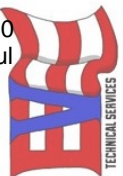
The discharge, or load test, is the recommended method of determining battery condition because it simulates electric vehicle operation under controlled conditions. A 75 amp draw is applied to the battery bank with a Load Tester. The time it takes the battery bank to drop to 31.5 volts, along with individual battery voltages, is used to determine battery condition.

**NOTICE: Use of automotive type of load tester is not recommended and will offer inaccurate results.**

**Use an appropriate volt tester that gives voltage and minutes of discharge.**

**Test Preparation**

The following preparations must be verified before discharged load testing. Should any of the following recommendations not be performed, results of testing will be inaccurate and misleading.



- Batteries must receive a full charge before conducting Discharge (Load) Test.
- Discharge (Load) Test must be performed within 18 hours of charging.
- Vehicle must not be used, even for short runs, prior to Discharge (Load) Test.
- Electrolyte level must be correct in all cells.

**Test Procedure**

**⚠ WARNING**

**Discharge Load Test must be performed in well ventilated area.**

1. Connect tester leads to battery bank.
2. Check and record electrolyte temperature of center cell of each battery.
3. Turn tester on.
4. After 20-30 minutes, with tester on, check and record individual battery voltages to the nearest 0.1 (1/10) volt.

All six individual battery voltage readings must be made as rapidly as possible to be accurate.

5. Allow tester to shut off automatically, and record time elapsed from start of discharge.

Tester shutoff should occur at a battery voltage of 42v +/- 0.2v (48 volt system) or 21v +/- 0.2v (24 volt system). Check tester shutoff voltage periodically. This setting must be accurate for a valid test.

**Results Interpretation**

1. Compare individual battery voltages recorded in step 4 of *Discharge (Load) Test Procedure* and discard any battery that is 0.2 (2/10) volt lower than the highest battery in bank. If defective battery is found, recharge the entire bank for 12 hours. Then, replace the defective battery with a good fully charged battery of the same brand and date code, if possible. Equalize the bank by placing it on charge for an additional three hours, then retest.
2. If all battery voltages are within 0.2 volts of each other, compare discharge time from step 4 of *Discharge (Load) Test Procedure* with minimum times in Temperature and Time Table. Even if individual battery voltages are satisfactory, but the discharge time fails to meet minimums in Temperature and Time table, the entire battery bank should be replaced.

<b>DISCHARGE LOAD TEST: Temperature &amp; Time</b>	
Electrolyte Temperature (Step 2)	Minimum Discharge Time (Step 5)
40-49° F (4-9° C)	40 Minutes
50-59° F (10-15° C)	45 Minutes
60-64° F (16-17° C)	50 Minutes
65-69° F (18-20° C)	54 Minutes
70-74° F (21-23° C)	57 Minutes
75-79° F (24-25° C)	60 Minutes
80-84° F (26-29° C)	62 Minutes
85-89° F (30-32° C)	64 Minutes
90-99° F (33-37° C)	66 Minutes
100-109° F (38-43° C)	68 Minutes
110-119° F (44-48° C)	70 Minutes
120-129° F (49-54° C)	72 Minutes
130-150° F (55-66° C)	74 Minutes

**Table 4**

**STORING BATTERIES**

- Batteries can remain in vehicle.
- Batteries should be fully charged.
- Clean battery tops and connections.
- Fully charged batteries should be stored in as cold of an environment as possible. Batteries “self discharge” when not in use. The colder the temperature, the slower batteries self discharge.

**⚠ CAUTION**

**Batteries in low state of charge (low specific gravity readings) will freeze at higher temperatures than those fully charged.**

Check specific gravity periodically, and recharge batteries as necessary. Batteries stored in temperatures above 80°F (26°C), will discharge faster and require recharge every few weeks. Batteries stored at or below 0°F (-12°C) may not require recharge for periods up to 4 months. When recharging, bring batteries to 1.250-1.270 specific gravity to prevent freezing. See Table 5.

State of Charge	Specific Gravity	F° Freezing point C°		Risk of Sulfation
100%	1.260	-70	-57	Low
75%	1.230	-39	-38	Low
50%	1.200	-16	-26	Low
25%	1.170	-2	-19	Moderate
Discharged	1.110	+17	-8	High

**Table 5**

Columbia / ParCar OEM Parts  
 evtechnicalservices.com  
 TECHNICAL SERVICES



As ice forms in a freezing battery, the electrolyte expands and can crack the case, ruining the battery. If a battery is allowed to stand or is operated in a discharged condition for a long period of time, lead sulfate may develop on the plates, which is dense, hard and crystalline, and which cannot be electrochemically converted to normal active material again. Lead sulfate formed on the plates during discharge is relatively insoluble as long as the specific gravity of electrolyte is kept above 1.125 specific gravity, but if allowed to drop below this value, the lead sulfate becomes increasingly soluble and may migrate into the pores of the separators and deposit as a white crystalline mass.

Subsequent charging may convert these deposits into stringy metallic lead which may short the positive and negative plates through the areas affected. These small shorts may cause a condition of low cell voltage when battery is allowed to stand idle in less than 25% charged condition.

### REPLACING BATTERIES

The batteries are located under the rear deck.

#### Removing Batteries

1. Remove nuts, washers and cables, positive lead and negative lead interconnecting batteries.
2. Remove nuts, flat washers, hold down plates and rods.
3. Remove batteries.

#### Installing Batteries

1. Install batteries.
2. Install rods and hold down plates.
3. Install flat washers, nylock nuts.
4. Install nuts, washers and cables, positive lead and negative lead interconnecting batteries.

### EXCESSIVELY DISCHARGED BATTERIES

**NOTICE:** The current on board Chargers will not charge a “dead” battery. Each battery will need to be brought up to an acceptable state of charge, and establish that it does not have an internal fault or bad cell.

If a battery has remained too long in a discharged state, it may be internally damaged and not capable of accepting a charge. It must be replaced.

If the individual battery voltage low, it will need to be recharged with an ordinary automotive style trickle charger. Follow specific charger instructions. It is not necessary to disconnect the battery cables, as the alligator style clips can be connected to each positive and negative battery post.

#### **WARNING**

**Always disconnect the AC power first when moving the positive/negative alligator clips to prevent a spark from igniting the gas emitted from the batteries.**

Be sure to charge all of the batteries in the set. Each battery may require 2-3 hours of charging to bring it back to serviceable condition. Measure the Specific Gravity (SG) of each cell after this charging procedure is completed, to verify that the battery is OK for use. Replace any batteries that can not be re-charged (no change or improvement in SG). After all batteries have been individually charged, and with the temporary automotive charger removed, try operating the Charger again to verify operation. Allow the Charger to complete a full charge cycle for proper equalization of batteries.



**COLUMBIA** 

**Columbia ParCar Corp.**

**Service Manual**

**Section 10**

**Traction Drive System**

Columbia / ParCar OEM Parts  
[evtechnicalservices.com](http://evtechnicalservices.com)



**TRACTION MOTOR**

**Maintenance**

A good planned maintenance program will save many hours of future down time and prevent catastrophic failure of major motor components. Maintenance schedules consist of periodic routine inspections of motors, battery and wiring circuitry.

Since operation of equipment varies widely, the following recommendations are suggested for periodic maintenance inspection:

- Normal service – 8 hours per day operation
- Routine inspection every 1,000 hours

- Severe service – 24 hours of daily operation
- Routine inspection every 500 hours

**NOTICE: Severe service would include; Dusty or sandy locations such as cement plant, lumber or flour mills, coal dust or stone crushing areas. High temperature areas such as steel mills, foundries, etc. Sudden temperature changes such as continuous in-door-outdoor movement, as in refrigeration plants.**

**External Inspection**

1. Check for clean, tight, terminal studs and mounting bolts.
2. Internal and external spline drives, between motor and final drive axle, must be periodically lubricated with a thin layer of quality, anti-seize compound.
3. Check for any signs of oil leaks from final drive axle, which might cause oil to enter traction motor.

**Internal Inspection**

The brush and commutator inspection is the most important part of motor maintenance. By recognizing undesirable commutator and/or brush conditions, internal repairs can be performed before major component damage or failure occurs.

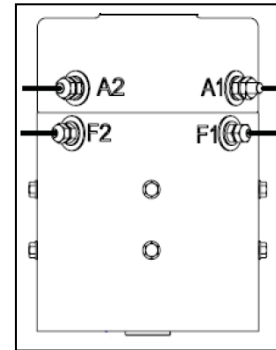
Brush and commutator inspection can be accomplished by removing the motor head. The brushes and commutator should be inspected for even wear and good commutation.

Good commutation will be indicated by a dark brownish, polished commutator and an evenly polished brush wearing surface. If the commutator appears rough, pitted, scored or has signs of burning or heavy arcing between the commutator bars, the motor should be removed for servicing.

**Removal**

**NOTICE: Studs and jam nuts on the electric motor can be damaged when attaching or removing electrical leads. Hold a thin open end wrench on the electrical stud connector jam nut while loosening or tightening attaching nuts.**

1. Mark traction motor cables (if not already marked), with motor terminal identification Figure 10-1.
2. F1 and F2 terminals are 1/4-20, A1 and A2 terminals are 5/16-18. Hold terminal jam nut with a thin open end wrench when loosening and removing hex nuts, lock washers and flat washers securing electrical cables to traction motor.



**Figure 10-1**

3. Carefully support motor to prevent it from falling.
4. Loosen and remove the three 1/4" bolts, lock washers and flat washers securing motor to rear axle/differential housing.
5. Pull motor away from rear axle housing and clear of the vehicle.

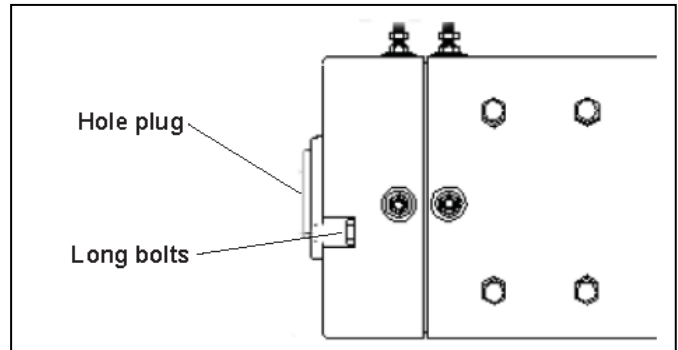
**CAUTION**

**Traction motor is heavy and awkward to move. Get help stabilizing and removal to prevent possible personal injury.**

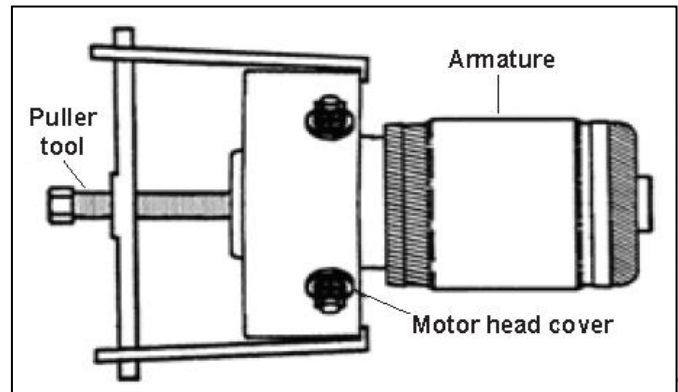
Columbia / ParCar OEM Parts  
 eotechnicalservices.com  
 TECHNICAL SERVICES

**Disassembly**

1. Remove long bolts. Remove motor head hole plug. See Figure 10-3.
2. Pull on motor head to remove armature from frame. A light tap may be required to loosen motor head from frame. Motor head and armature come out together.
3. Place puller around the motor head. Use the center of the shaft to locate puller. See Figure 10-4.
4. Pull motor head assembly off of armature assembly maintaining equal pressure on all sides of head.
5. Move brush springs behind spring hooks shown in Figure 10-5.
6. Remove 1 hex nut, 1 lock washer, 1 hex nut, 1 flat washer and 1 insulator at each brush terminal, A1 and A2. Figure 10-6.
7. Remove 4 brush plate screws (Figure 10-7). Push brush terminal studs through, into the center of the head as the brush box, brushes and terminal assemblies are removed. (See exploded view Figure 10-9).
8. Remove bearing retainer (snap ring) shown in Figure 10-5. Carefully press out the bearing from motor head. Replace the bearing.
9. Remove all the brush dust from motor frame, brush box, and motor head.



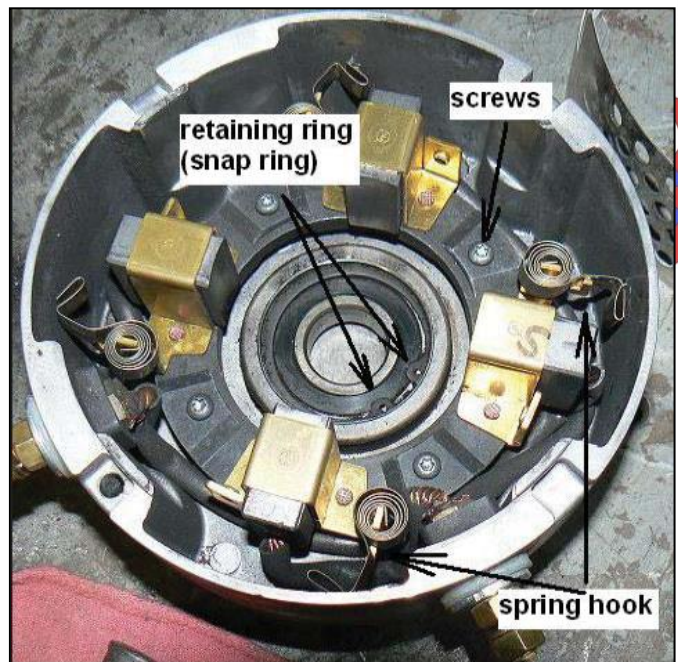
**Figure 10-3**



**Figure 10-4**

**Armature Inspection**

1. Measure the diameter of the armature (Figure 10-8).
  - Max dia. when new 2.92-2.93" (74 mm)
  - Min dia. for re-slotting 2.81" (71 mm)
  - Replacement dia. 2.76" (70 mm)
2. Support the armature at both bearing journals. Check runout of commutator with a dial indicator. Total indicated runout should not exceed 0.005" (0.12 mm). If the readings fall outside this limit, commutator must be turned and undercut. See Figure 10-10.
3. After the commutator has been undercut, if required, the armature should be placed in lathe and the commutator lightly sanded with no. 00 sandpaper. This will remove any burrs left from the undercutting operation.
4. Clean commutator with dry, compressed air. Recheck commutator runout.



**Figure 10-5**

Columbia / ParCar OEM Parts  
 evtechnicalservices.com  
 TECHNICAL SERVICES



**Armature Testing**

Before the armature is reassembled into the motor, the following test should be performed.

1. Check armature for grounded circuits by placing one test lead of a Dielectric Breakdown Tester, also referred to as a “growler”, on the commutator and other lead at armature shaft. The ground test light should not flash. A flash indicates failed insulation between core and armature wiring. See Figure 10-11.
2. For short circuit connection, use a hacksaw blade to locate any shorted windings. Rotate armature slowly in growler jaws and hold a hacksaw blade in parallel against top of armature. The steel blade will be attracted to the core and will vibrate when two shorted armature coils are located. See Figure 10-12.

**Brushes**

Brushes should be inspected for uneven wear and signs of overheating, such as discolored brush leads and brush springs. Check brush box for physical damage. Make sure brush holders are not loose on the brush box assembly. See Figure 10-9.

Check brush for correct clearance and freedom of movement in the holder.

New brush length: 1.20" (30.5 mm)

Minimum brush length: 0.60" (15.2 mm)

Replacement brush length: less than 0.60" (15.2 mm). If any brushes are worn to the point that replacement is necessary, the complete brush set should be replaced. Never replace just one pair of brushes.

Do not substitute brushes. The brushes are matched to the motor type and application to provide the best service. Substituting brushes of the wrong grade can cause commutator damage or excessive brush wear.

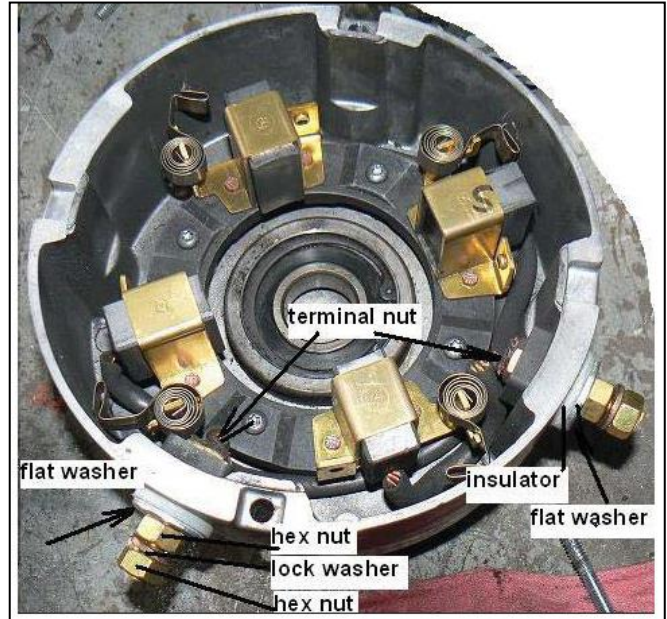
**Brush Springs**

Check the brush springs for correct alignment on the brush. A brush spring that does not apply equal pressure on the center of the brush will cause the brush to wear unevenly.

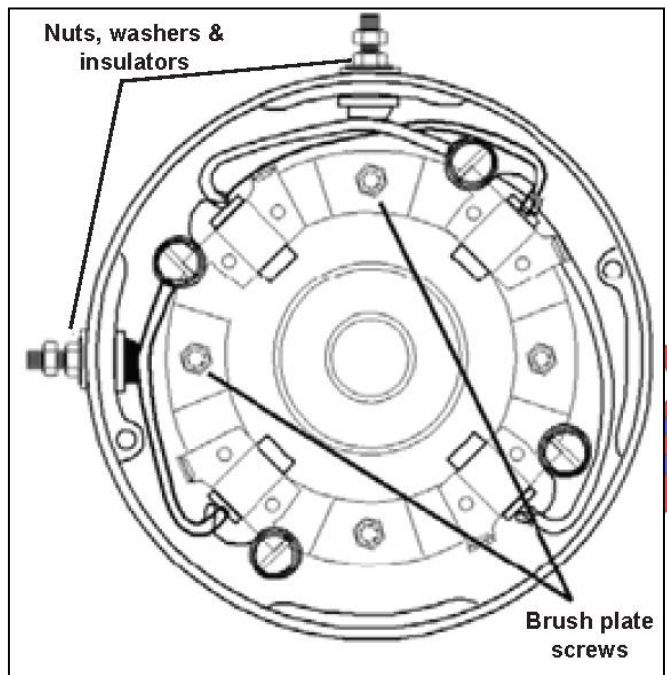
Use the following procedure for checking brushes for proper tension. See Figure 10-13.

1. Place paper strip between brush face and commutator.
2. Hook a commercial spring scale as shown.
3. Pull spring scale on a line directly opposite the spring force. When paper strip can be moved freely, read spring tension on scale.

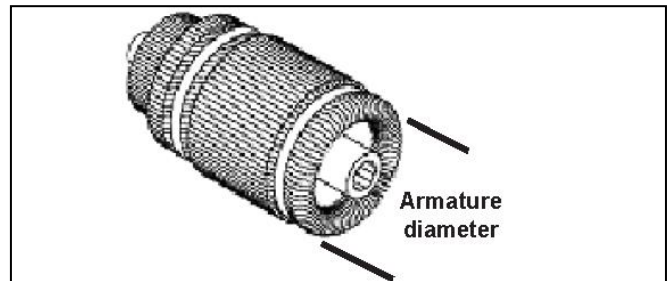
Brush spring tension      New 64 ounces (1792 grams)  
    Worn 40 ounces (1120 grams)



**Figure 10-6**

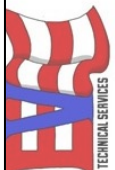


**Figure 10-7**



**Figure 10-8**

Columbia / ParCar OEM Parts  
 eotechnicalservices.com



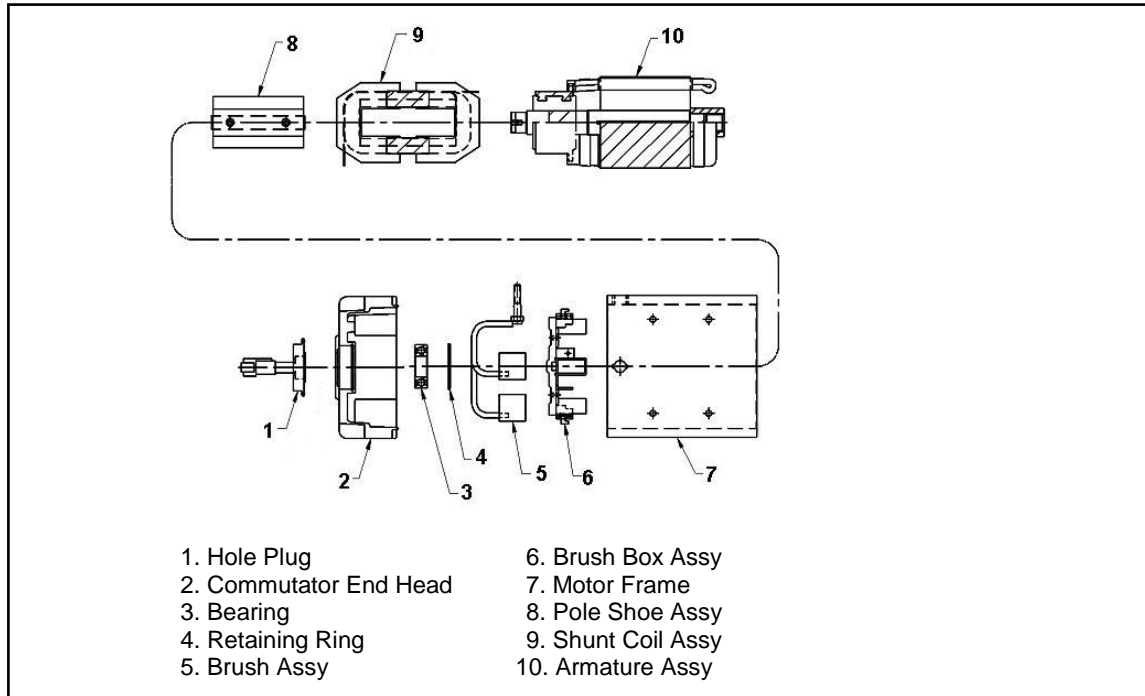


Figure 10-9

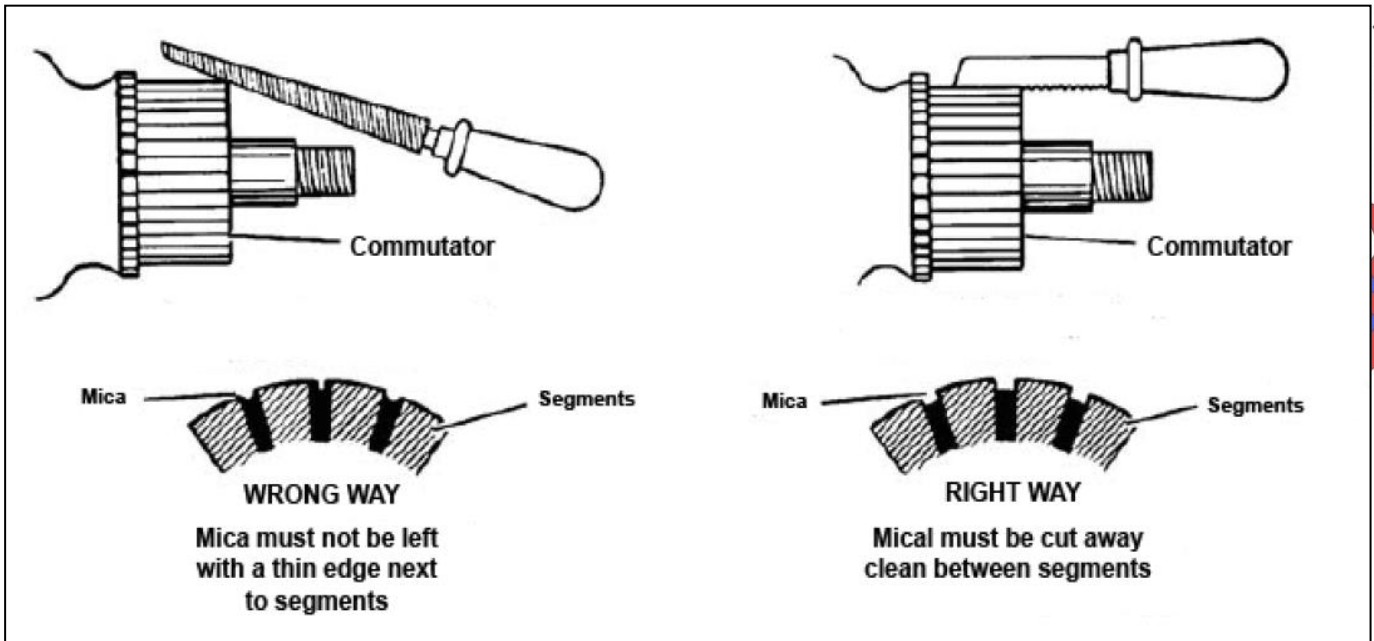


Figure 10



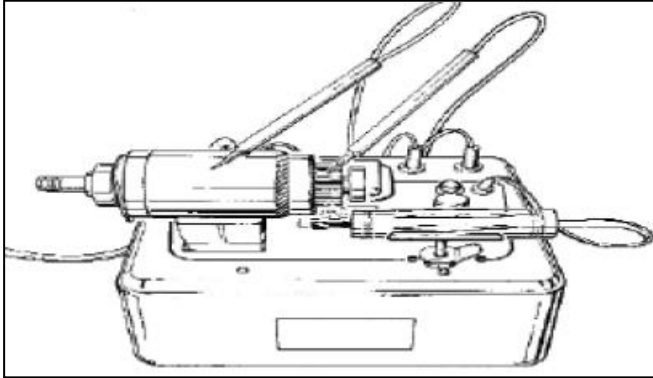


Figure 10-11

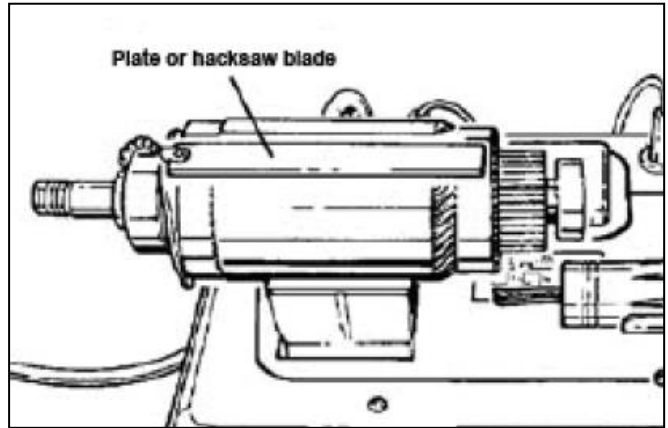


Figure 10-12

**Bearing**

After the motor has been disassembled, it is recommended that a new bearing be installed. Bearing may appear and feel ok; however, bearing may have been damaged during removal.

**Frame and Field Coils**

**NOTICE: Do not remove the field coils (9 Figure 10-9), from the motor frame unless it is absolutely necessary for repair. Removal and re-installation could shorten field coil life.**

There should be no continuity between the frame of the motor and field coil (Figure 10-9). Set the volt ohm meter (VOM) to measure Ohms. See Figure 10-14.

**Field Coil Maintenance** - NOT recommended by Columbia.

**Inspection**

Motors that have been disassembled for servicing should also include a complete inspection of the frame and field assembly. It is not uncommon for the frame and field assembly of a motor to become exceptionally dirty after many hours of operation. This may result in a grounding condition due to dirt, grease and other foreign materials.

**Motor Reassembly**

1. Always use a new bearing when reassembling a motor. Press bearing into motor head. Press only against the outer race. See Figure 10-15. Install snap ring to retain bearing. Figure 10-16.
2. Assemble brush assemblies into brush box assembly.
3. Position brush holder into motor head as shown in Figure 10-16. Make sure that the terminals for the brushes are loose and free.
4. Install insulators and brush leads into motor head. See Figure 10-17. Brush motor terminals, A1 and A2, should be torqued to 140 in. lbs. (15.8 Nm).

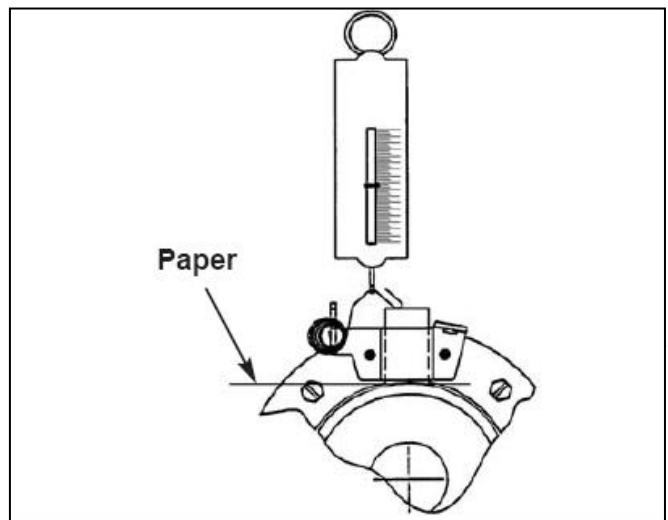


Figure 10-13

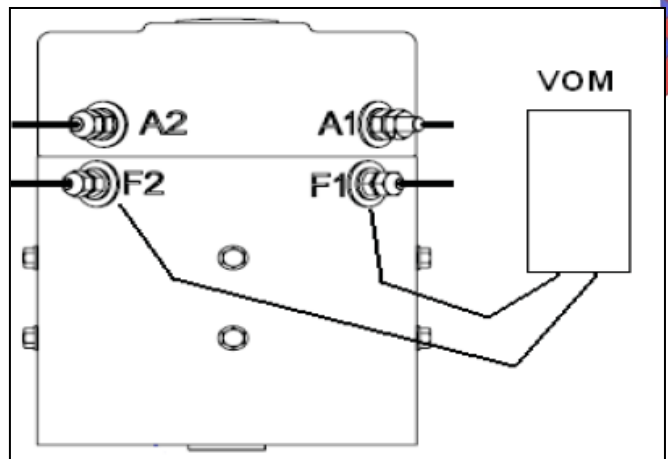


Figure 10-14

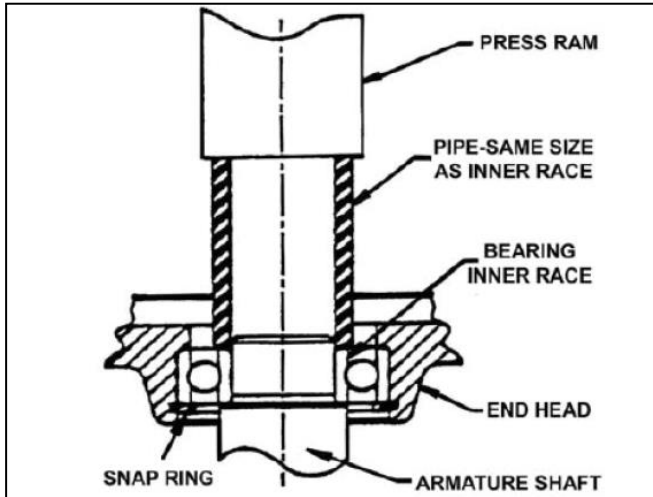


Figure 10-15

5. Pull back each brush in its holder, allowing the spring to rest against the side of each brush. This will hold each brush in place, preventing interference and damage to commutator and brushes during armature installation.
6. Press motor head and bearing onto armature, pressing only against inner race of the bearing. See Figure 10-15.
7. Check that head and bearing rotates freely, without noise or irregular interference. Press brushes inward against armature commutator. Relocate the springs to push on the brushes. Check that brushes ride smoothly on the commutator.
8. Install motor head and armature assembly into field coil and frame assembly, aligning armature terminals to field coil terminals.
9. Install two bolts securing motor head to frame. Make certain motor head is completely seated to the frame before tightening. Torque bolts to 156 in. lb. (17.6 Nm).

**Motor Installation**

1. Coat open end of the armature and rear axle input shaft with Anti-Seize compound. Insert a new rubber bumper into open end of armature. Place motor into vehicle and onto input shaft.
2. Rotate motor to align mounting bolt holes to axle/differential housing. Install 3 bolts securing motor to rear axle/differential housing, while carefully supporting motor to prevent it from falling. Loosely tighten screws A and B, then loosely tighten screw C to draw face of motor up to flange on axle evenly (Figure 10-18). Torque screws A and B to 100 in. lbs. (11.3 Nm). Then tighten screw C to 100 in. lbs. (11.3 Nm).
3. Inspect electrical system cables for terminal identification (A-1, A-2, etc.). Position cables to traction motor, double checking wiring diagram to motor cable installation to ensure connections are correct.

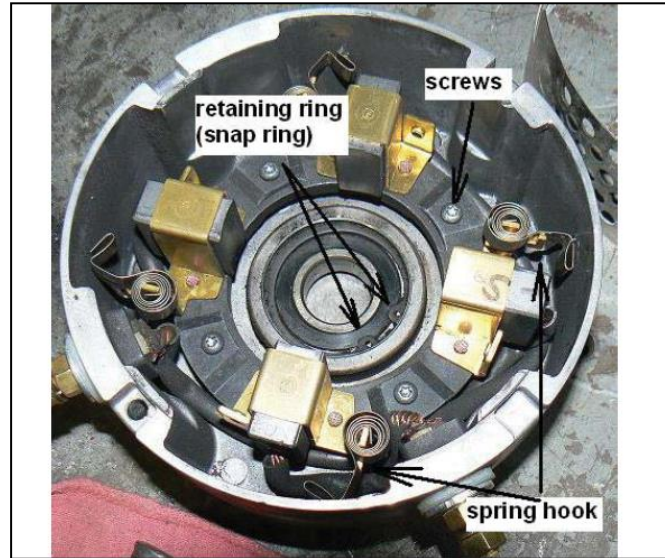


Figure 10-16

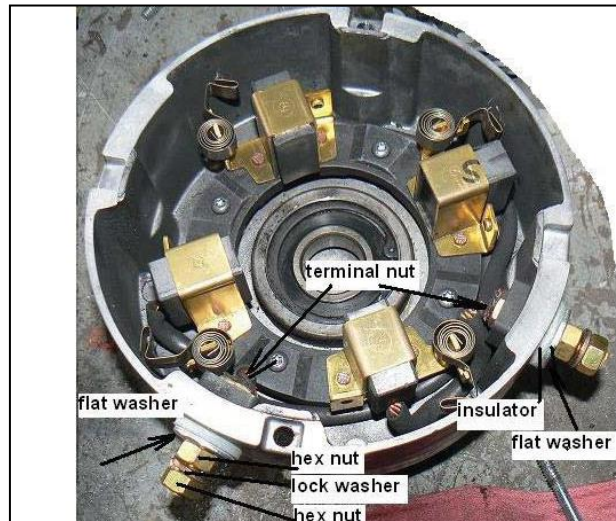


Figure 10-17

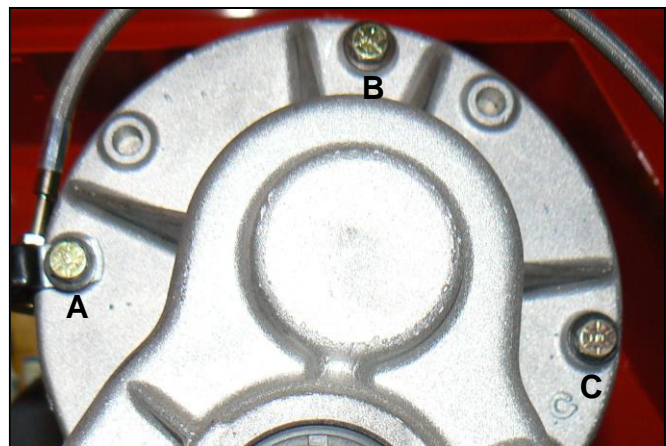


Figure 10-18



4. F1 and F2 terminals are 1/4-20 while A1 and A2 terminals are 5/16-18. Attach cables with flat washers, lock washers and hex nuts. Torque A1 & A2 cable attaching nuts to 110 in. lbs. (12.4 N m), while holding the bottom nut, with a thin open-end wrench. Torque F1 & F2 cable attaching nuts to 50 in. lbs. (5.7 Nm), while holding the bottom nut, with a thin open end wrench.
5. Place vehicle on the ground or onto dynamometer to test motor operation.

**CAUTION**

**Do not run motor at full voltage without a load.**

**CONTROLLER**

**ACEplus System**

The ACEplus System is an advanced traction drive system that uses a fully integrated, solid state Sevcon Controller for speed regulation and forward/reverse control. Combined with a separately excited DC motor, the system provides optimized power efficiency through pedal proportional speed control and regenerative braking. This control system is ideal for hilly terrain or areas with multiple ramps. It is also used for towed loads and high braking demands. The ACEplus system is distinguished by a 6 post controller. See Figure 10-19.

**Testing**

Do not remove the controller. It can be tested while still in the vehicle.

1. Look for the steady green light on the dash system status light. If it is a steady green, the system is OK and ready.
2. If it is flashing, count the number the flashes in each sequence. Refer to *Section 4 - Troubleshooting* for controller flash troubleshooting info, and for info on testing controller with Sevcontrol Calibrator or PC Pak computer interface.
3. If the tests indicate that the controller has failed, replace it.

**Removing**

1. Disconnect battery negative cable and remove Power key.
2. See *Section 8 – Body and Chassis* for removal and installation.
3. Label/mark controller cables with controller terminal identification, if not already labeled.

**NOTICE: The controller terminal bolts and washers are Metric. Metric wrenches are required to remove the controller cable fasteners. The fasteners that attach the controller to the vehicle frame are SAE U.S.**

3. Remove six metric bolts, lock washers, flat washers and all the cables and wires connected to the controller.
4. Remove 16 pin controller connector (Figure 10-19).

See *Columbia Service Bulletin 06-010* if the wiring harness or connector is damaged.

**NOTICE: Do not attempt to disassemble the controller. There are no repairable parts inside.**

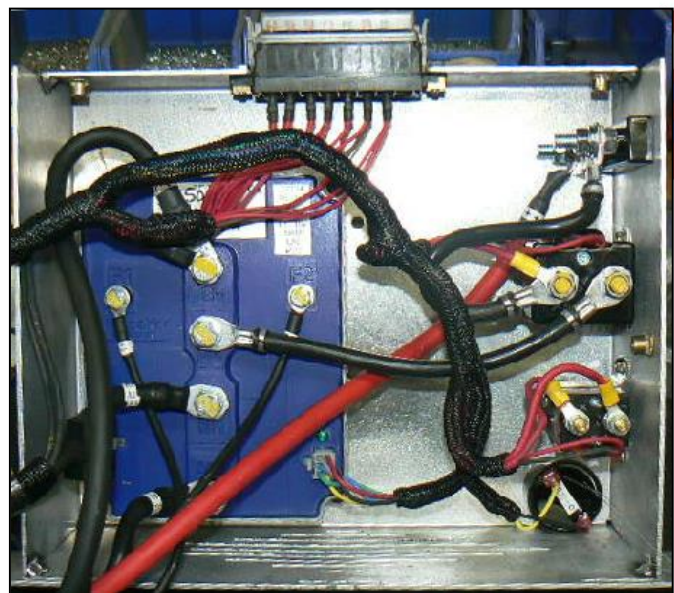
5. After installation perform an operational check of the vehicle's driving abilities.

**CONTACTOR(S)**

Contactors are electro-magnetic switches that energize when current is applied to the small control circuit terminals. When energized, the solenoid core moves up from magnetism created by the coil and internal contacts, creating a connection between two large terminals, allowing current to pass through.

When control circuit voltage is removed from the small terminals, the magnetic field collapses and a spring returns the core to its rest position. A contact solenoid in the normal position has an open circuit between the large terminals, preventing current from passing through it.

The contactor is located in the controller metal case. See *Section 8 – Body and Chassis* for removal and installation. This case also contains the 300 amp fuse, the reverse beeper, the main contactor, and the accessory contactor. See Figure 10-19



**Figure 10-19**



**Columbia ParCar Corp.**

1115 Commercial Avenue • Reedsburg, WI 53959  
Phone: (608) 524-8888 • (800) 222-4653 • Web: [www.parcars.com](http://www.parcars.com)

Columbia / ParCar OEM Parts  
**evtechnicalservices.com**

