



**Columbia ParCar Corp.**

## **SERVICE MANUAL**

**Multiple Vehicle Platform**

**MV1-S, MV1-L**

**GENERAL**

This service manual has been prepared with two purposes. First, it will introduce the trained maintenance professional to the latest field tested and factory approved major repair methods. Secondly, it will acquaint the reader with the construction of the Columbia ParCar vehicles and assist him/her in performing basic maintenance and repair. We sincerely believe that this manual will make the association with Columbia ParCar vehicles a more pleasant and profitable experience.

In addition to the information given in this manual, Service Bulletins are issued to Columbia ParCar dealers which cover interim engineering changes and supplementary information. Service Bulletins should be consulted for complete information on the models covered by this manual.

To ensure the safety of those servicing our vehicles and to protect the vehicles from possible damage resulting from improper service or maintenance, the procedures in this manual should always be followed exactly as specified. Execution of the procedures and troubleshooting tips as outlined will ensure the best possible service from the vehicle(s). To reduce the chance of personal injury and/or property damage, carefully observe the DANGER, WARNING, CAUTION & NOTICE recommendations throughout this manual. See *Section 1 Safety* for additional details.

These vehicles are not designed for over-the-road use. They do not conform to Federal Motor Vehicle Safety Standards or EPA regulations, and are not equipped for operation on public streets, roads, or highways.

To the best knowledge of Columbia ParCar Corp., the material contained herein is accurate as of the date this publication was approved for printing. Columbia ParCar Corp. is not liable for errors in this manual or for incidental or consequential damages that result from the use of the material in this manual. Columbia ParCar Corp. reserves the right to change specifications, equipment or designs at any time without notice and without incurring obligation.

This manual contains proprietary information that is protected by copyright. All rights are reserved. No part of this manual may be photocopied, reproduced, or translated to another language without the written consent of Columbia ParCar Corp. Columbia ParCar Corp. products are manufactured under one or more of the following U.S. Patents - 2986162, 2987934, 3116089, 3144631, 3144860, 3229792, 3434887, 3559773, 3673359, 3680403, 3683716, 3709317, 4648473, Des. 225626.

**PREPARATION FOR SERVICE**

Proper preparation is very important for efficient service work. A clean work area at the start of each job will allow you to perform the repair as easily and quickly as possible, and reduce the incidence of misplaced tools and parts. Columbia ParCar vehicles that are excessively dirty should be cleaned before work begins. Cleaning will occasionally uncover trouble sources.

Tools, instruments and parts needed for the job should be gathered before work is started. Interrupting a job to locate tools or parts is a needless delay. Special tools required for a job are listed at the beginning of each section.

**MODEL IDENTIFICATION**

Always give the vehicle identification number (VIN) when ordering parts or making inquiries about the vehicle. Use of the full and complete vehicle identification number will ensure that the dealer or service provider is supplying you with the correct parts for the vehicle. See *Section 2-General Information* for VIN location and additional information.

**USE GENUINE REPLACEMENT PARTS****WARNING**

When replacement parts are required, use only genuine Columbia ParCar parts or parts with equivalent characteristics including type, strength and material. Failure to do so could result in product malfunction and possible injury to the operator and/or passenger.

To ensure a satisfactory and lasting repair, follow the service manual instructions carefully and use only genuine Columbia ParCar vehicle replacement parts. This is the insurance that the parts you are using will fit right, operate properly and last longer. When you use genuine Columbia ParCar vehicle parts, you use the best.

**PRODUCT REFERENCES**

When reference is made in this manual to a specific brand name product, tool or instrument, an equivalent product, tool or instrument may be used in place of the one mentioned.



<b>SECTION 1 – SAFETY</b>			<b>SECTION 4 – TROUBLESHOOTING Cont.</b>	
Overview	1-1		Vehicle Will Not Move; Forward or Reverse – LED Diagnostic Guide	4-5
Safety Information	1-1		Vehicle Drives Slowly	4-6
Antidotes	1-1		Vehicle Drives in Forward or Reverse Only	4-6
Icons in Procedures	1-2		Vehicle Drives But Operation is Jerky or Inconsistent	4-6
Safety Preparations	1-2		Vehicle Power Cuts Out	4-6
Decal	1-2		Flash Codes and Corrective/Investigative Actions	4-7
<b>SECTION 2 – GENERAL INFORMATION</b>			Component Troubleshooting	4-8
Vehicle Model Information	2-1		Battery Discharge Indicator	4-8
Vehicle Identification Number (VIN)	2-1		Brake Lights and Auxiliary Switch	4-8
VIN Matrix	2-1		Reverse Beeper	4-8
VIN Label	2-1		Head Light & Tail Light	4-8
Safety Concerns	2-1		Power Outlet	4-9
Controls and Operation	2-1		Brake Light	4-9
Power Keyswitch	2-1		Brakes	4-9
Direction Selector	2-1		Slow or Incomplete Release Of Brakes	4-9
Auxiliary Equipment Switch	2-2		Wheel Bearings	4-9
Warnings/Operating Instructions	2-2		Air In Hydraulic Lines	4-9
Horn Button	2-2		Severe Reaction To Pedal	
Brake Pedal	2-2		Pressure And Uneven Stopping	4-9
Accelerator Pedal	2-2		Brakes Squealing, Clicking or Scraping Noises	4-9
Parking Brake	2-2		Cab Heater	4-9
High/Low Speed Switch	2-2		<b>SECTION 5 – ACCELERATOR &amp; BRAKE SYSTEM</b>	
Turn Signal/Hazard Switch	2-2		Vehicle Service	5-1
Seat Switch/Traction Interlock	2-2		Accelerator Pedal	5-1
Wiper	2-2		Rear Hydraulic Brake System	5-1
Hour Meter Indicator	2-2		Periodic Brake Inspection	5-1
Charger Receptacle(s)	2-2		Annual Brake Inspection	5-1
Steering Wheel	2-2		Drum Brake Disassembly	5-2
Battery State Of Charge Meter	2-3		Brake Drum Service	5-3
Inspection Doors	2-3		Drum Brake Reassembly	5-4
Pre-Operation Inspections	2-3		Front Disc Brakes	5-4
Pre-Operation Checklist	2-4		Brake Caliper Service	5-4
<b>SECTION 3 – MAINTENANCE</b>			Hub/Rotor Service	5-5
Maintenance Guidelines	3-1		Hydraulic Brake Adjustments	5-5
Periodic Service Calendar	3-1		Brake Linkage Adjustment	5-5
Service & Maintenance Schedule	3-2		Brake Fluid Maintenance	5-5
Checklist – Tires & Wheels	3-2		Bleeding The Brake System	5-6
Checklist – Operating Controls	3-2		<b>SECTION 6 – FRONT WHEEL, SUSPENSION &amp; STEERING</b>	
Checklist – Electrical	3-3		Wheels	6-1
Checklist - Electric Motor	3-3		Removing Wheels	6-1
Checklist – Fluids	3-3		Installing Wheels	6-1
Differential Fluid Levels	3-3		Tires – Pneumatic	6-1
Lifting Instructions	3-4		Front Wheel Hub Assembly	6-1
Hoist Lifts	3-4		Removal	6-1
Floor Jack	3-4		Installing	6-1
Vehicle Storage	3-4		Front Axle Removal	6-2
Returning Vehicle to Service	3-5		Steering	6-2
Transporting a Vehicle	3-5		Steering Adjustments	6-2
<b>SECTION 4 – TROUBLESHOOTING</b>			Alignment	6-2
Pre-troubleshooting Steps	4-1			
Battery Testing	4-1			
Troubleshooting Specific Complaints	4-2			
Vehicle Will Not Move; Forward or Reverse	4-2			
Troubleshooting With PCPAK	4-3			
Troubleshooting With Handheld Calibrator	4-5			

**SECTION 7 – REAR AXLE**

Rear Axle Wheel Bearings	7-1
Removing Rear Axle	7-1
Disassembling Rear Axle	7-1
Axle Exploded View	7-2
Assembling Rear Axle	7-5
Installing Rear Axle	7-7
Changing Differential Oil	7-7
NKL Axle 16.77	7-8

**SECTION 8 - BATTERY AND BATTERY CHARGER**

Important information	8-1
Safety Information	8-1
Antidotes	8-1
Battery Inspection & Maintenance	8-1
Battery Cleaning	8-1
Battery Service (Water)	8-2
Adding Water	8-2
Single Point Watering System	8-2
Battery Charging	8-3
Charger Safety Information	8-3
Battery Brand Algorithms	8-4
Delta Q Charger Operation	8-5
Single LED Display	8-6
Red Light Charger Error Codes	8-6
Charging Procedure	8-6
Testing Batteries	8-6
Specific Gravity Test	8-6
Hydrometer Test	8-6
Results Interpretation	8-7
Discharge (Load) Test	8-7
Test Preparation	8-7
Test Procedure	8-7
Results Interpretation	8-8
Storing Batteries	8-8
Replacing Batteries	8-8
Removing Batteries	8-8
Installing Batteries	8-8
Excessively Discharged Batteries	8-9

**SECTION 9 – TRACTION DRIVE SYSTEM**

Traction Motor	9-1
Maintenance	9-1
External Inspection	9-1
Internal Inspection	9-1
Removal	9-1
Disassembly	9-2
Armature Inspection	9-2
Armature Testing	9-3
Brushes	9-3
Brush Springs	9-3
Motors Exploded View	9-4
Bearing	9-5
Frame and Field Coils	9-5
Field Coil Maintenance	9-5
Inspection	9-5
Motor Reassembly	9-5
Motor Installation	9-6

**SECTION 9 – TRACTION DRIVE SYSTEM Cont.**

Controller	9-7
ACEplus System	9-7
Testing	9-7
Removing	9-7
Installing	9-7
Contacto(r)s	9-7
Removing	9-8
Installing	9-8



CHANGE HISTORY - MVP		
DATE	DESCRIPTION	BY
5-24/12	Issued	TS
10/30/13	Added NKL axle	TS

**COLUMBIA** 

**Columbia ParCar Corp.  
Service Manual**

**Section 1 Safety**

**OVERVIEW**

Statements in this manual preceded by the words **DANGER**, **WARNING**, **CAUTION** or **NOTICE** and words printed in **bold face** are very important. We recommend you take special notice of these items.

**⚠ DANGER**

**Danger indicates a hazardous situation which, if not avoided, will result in death or serious injury.**

**⚠ WARNING**

**Warning indicates a hazardous situation which, if not avoided, could result in death or serious injury.**

**⚠ CAUTION**

**Caution indicates a hazardous situation which, if not avoided, could result in minor or moderate injury.**

**NOTICE:** Notices are messages not related to personal injury. They will provide key information to prevent property damage and to assure procedures are more easily understood or implemented.

It is important to note that some warnings against the use of specific service methods, which could damage the vehicle or render it unsafe, are stated in this service manual. However, please remember that these warnings are not all inclusive. Since Columbia ParCar Corporation could not possibly know, evaluate and advise servicing personnel of all possible ways in which service might be performed or of the possible hazardous consequences of each way, we have not undertaken any such broad evaluation.

Accordingly, anyone who uses a service procedure or tool which is not recommended by Columbia ParCar must first thoroughly satisfy him/herself that neither their nor the operator's safety will be jeopardized by the service methods selected.

**SAFETY INFORMATION**

It is Columbia ParCar's specific recommendation that the following safety information must be observed at all times. Not all are repeated throughout this manual, but the recommendations included must be observed whenever these subjects (indoor vehicle operation hazards) are encountered.

**⚠ WARNING**

**Any modifications or changes to the vehicle that affect the stability or increases vehicle speed beyond factory specifications could result in severe personal injury or death. Always, remove keys and turn the master disconnect switch counterclockwise to the OFF position before servicing or repairing your vehicle. See *Section 8-Battery and Charger*, for specific details.**

**⚠ DANGER**

**All batteries used in electric vehicles can explode! Always wear full face shield when working on or near batteries. Hydrogen fumes are a natural byproduct of charging and discharging and are extremely explosive.**

**Do not smoke around electric vehicle batteries. Keep sparks and flames away from batteries. Battery charging should only be done in a well-ventilated area. Refer to *Section 8-Battery and Charger* for details.**

**Batteries contain acid which can cause severe burns. Avoid contact with skin, eyes, or clothing. Wear full face shield and rubber gloves when working on or near batteries.**

**Antidotes**

- **External:** Flush with water. Call a physician immediately.
- **Internal:** Drink large quantities of milk or water. Follow with milk of magnesia or vegetable oil.
- **Eyes:** Flush with water for fifteen minutes. Call a physician immediately.

**⚠ WARNING**

**When working around batteries, use approved insulated tools, remove jewelry such as rings, watches, chains, etc. and place an insulating material such as wood, plastic, rubber, etc. over batteries covering all connections.**

**If any problems are found during scheduled maintenance or inspections, do not operate vehicle until repairs are completed. Failure to make necessary repairs could result in fire, property damage, severe personal injury or death.**

**⚠ DANGER**

**Only trained maintenance professionals should repair or service this vehicle. Persons performing even simple repairs or service should have working knowledge and experience in general electrical and mechanical repair. Follow all procedures exactly and observe all warnings stated in this manual. Use caution and common sense.**

Proper service and repair is important for safe, reliable operation of all Columbia vehicles. The service procedures recommended and described in this service manual are effective methods for performing service operations. Some of these service operations require the use of tools specially designed for this purpose. These special tools should be used when and as recommended.

**ICONS IN PROCEDURES**

Watch out for icons and symbols in procedures. They are there to help you avoid situations that might expose you to an unnecessary hazard or potential injury.

**⚠ DANGER**

Use insulated tools when working near batteries or electrical connections. Use extreme caution to avoid shorting of components or wiring.

**⚠ CAUTION**



**Moving parts hazard!** When operating any vehicle in a stationary position, avoid chains, belts, and wheels which could snag clothing or cause severe injury to body parts. A running vehicle must be worked on with the greatest care. Use caution and common sense.

**⚠ DANGER**

Do not wear loose clothing or jewelry such as rings, watches, chains, etc. when servicing the vehicle. Failure to do so could result in personal injury or death.

**⚠ WARNING**

Working on Columbia ParCar vehicles without following proper procedures and using proper lifting equipment may result in vehicle damage or personal injury. See *Section 3 Maintenance - Lifting Instructions* for detailed instructions.

Always wear safety glasses or approved eye protection while servicing vehicle. Wear a full face shield when working with batteries.

Failure to maintain vehicle properly could result in decreased vehicle performance, reliability or cause severe personal injury.

Exceeding rated vehicle load capacities could result in possible severe injury or property damage.

**⚠ CAUTION**

Check the vehicle for proper location and condition of all vehicle safety and operation decals. Refer to Section 2 for locations.

**NOTICE:** The modification of vehicles for use in other than its intended purpose is not recommended. Any unauthorized modification may void your vehicle warranty.

**⚠ CAUTION**



**HOT! DO NOT attempt to service hot electric motor or resistors. Failure to observe this warning could result in severe burns.**

The Payloader is a vehicle built to carry 2 or more people and cargo. It is not designed to be driven on public highways.

This vehicle is designed to conform to requirements for Type E vehicles as described in O.S.H.A. Standard Section 1910.178 (Powered Industrial Trucks) and with all applicable portions of the American National Standard for Personnel and Burden Carriers (ANSI B56.8 1993 Part III).

**SAFETY PREPARATIONS**

**⚠ DANGER**

Before performing any service on the vehicle, always turn Power keyswitch to OFF and remove. Turn Directional knob to NEUTRAL. Block tires.

**DECAL**

Warning/Operating Instructions decal should be ordered and replaced as soon as they are discovered to be illegible or missing. Part number for the MVP decal is 53258-07 (Figure 1-1).

<p><b>⚠ WARNING</b></p> <p>For personal safety and to maintain vehicle stability and control, operate this vehicle in accordance with the Owner and Operator Manual and under these conditions only. Failure to comply with warnings may result in bodily injury and property damage.</p> <ul style="list-style-type: none"> <li>• Before operating, read the Owner and Operator Manual.</li> <li>• Do not operate while under the influence of alcohol or drugs.</li> <li>• Operate in designated areas, by authorized persons.</li> <li>• Operate vehicle from driver's side only.</li> <li>• Never exceed vehicle capacity indicated on Vehicle Identification Label.</li> <li>• Do not start nor operate until and unless all occupants are seated.</li> <li>• Remain seated and hold on when vehicle is moving.</li> <li>• Keep entire body inside vehicle.</li> <li>• Drive slowly straight up and down slopes and in turns.</li> <li>• Use extra caution while turning or backing up.</li> <li>• Set parking brake and turn Power switch to OFF before leaving vehicle.</li> <li>• Remove key if vehicle is unattended.</li> </ul> <p><small>This vehicle does not comply with National Highway Traffic Safety Administration code for on-road use. Refer to the Owner and Operator Manual for proper vehicle use and operation.</small></p>	<p><b>OPERATING INSTRUCTIONS</b></p> <ol style="list-style-type: none"> <li>1) Confirm Direction switch is set to Neutral (N).</li> <li>2) Confirm accelerator pedal is NOT depressed.</li> <li>3) Turn Power switch to ON.</li> <li>4) Allow system to energize for at least two seconds.</li> <li>5) After power up, select forward (F) or reverse (R) with Direction switch.</li> <li>6) Release parking brake.</li> <li>7) Press accelerator pedal to travel in the chosen direction.</li> </ol> <p>When finished using vehicle</p> <ol style="list-style-type: none"> <li>1) Set parking brake and select Neutral (N) with the Direction switch.</li> <li>2) Turn the Power switch to OFF.</li> <li>3) Remove key if vehicle is unattended.</li> <li>4) Connect vehicle charge cord to approved AC power outlet.</li> </ol> <p><b>Stop vehicle before reversing direction.</b></p> <p><b>NOTICE:</b> If vehicle is transported and/or stored for more than 5 days, set the power switch, located on the dash panel, to OFF. (If left on, severe discharge and/or battery damage may result.)</p>
---	---

**Figure 1-1**





**Columbia ParCar Corp.  
Service Manual**

**Section 2 – General Information**



Columbia / ParCar OEM Parts  
[evtechnicalservices.com](http://evtechnicalservices.com)

**VEHICLE MODEL INFORMATION**

<b>Direct Drive Axle</b>	Single or Dual
<b>Battery Pack</b>	Single or Dual
<b>Brakes</b>	2 / 4 / 6 Wheel Hydraulic
<b>Power System</b>	48 Volt ACEplus
<b>Load Deck Area</b>	48" Wide x 72" or 96" Long
<b>Tires</b>	145R12

**VEHICLE IDENTIFICATION NUMBER (VIN)**

Each vehicle has a unique VIN. The VIN describes facts and features of the vehicle and contains thirteen (13) digits.

**VIN MATRIX**

<b>Digit 1 thru 3 = Abbreviation (Model)</b>	<b>MVX = (Multiple Vehicle platform)</b>
<b>Digit 4 = Power System</b>	<b>E = Sep Ex, Regen: (ACEplus)</b>
<b>Digit 5 = System Voltage</b>	4 = 48V (8 – 6V)
	B = 48V (4 – 12V)
	D = Dual 48V (8 – 6V / 8 – 6V)
	M = AGM (8 -6V)
<b>Digit 6 = VIN Spacer</b>	- = normal
	# = Special Product
<b>Digit 7= Controller Amperage</b>	4 = 400 Amp
	5 = 500 Amp
<b>Digit 8 = Axle/Brake System</b>	P = Dual H12 Hvy Duty: Rear Hydraulic
	R = Dual H12 Hvy Duty: F & R Hydraulic
<b>Digit 9 = Build Year</b>	L = 2012, M = 2013, N = 2014 etc.
<b>Digit 10 Thru 13 – Build Sequence</b>	1234

The VIN can be found on the VIN label attached to the dashboard near the steering column. The nameplate has important information such as model, vehicle weights and rated capacity (load, operator and passenger). Do not exceed this capacity. Read carefully.

**VIN LABEL**

<p>Electric Utility Vehicle Information</p> <p>Model:</p> <p>Vehicle Identification Number (V.I.N.):</p> <p>Rated Capacity Including Passengers &amp; Operator: □□□lbs.(□□□kg.)</p> <p>Operating Weight: □□□lbs. (□□□kg.)</p> <p>Without Batteries: □□□lbs. (□□□kg.)</p> <p>Maximum Service Weight Of Batteries: □□□lbs. (□□□kg.)</p> <p>This Carrier Is Designed For □□V (Normal)</p> <p>Designed To Conform With The Mandatory Requirements Of ASME/ANSI B56.8 Part III, ANSI/UL 583 Type E And OSHA 1910.178</p> <p><b>Columbia ParCar Corp.</b> Reedsburg, WI USA</p>
---

**SAFETY CONCERNS**

- Enforce safe driving and operating rules.
- Provide driver training for first time operators and review safe operating recommendations regularly.
- Maintain vehicles in a safe operating condition and maintain a schedule for daily, weekly, monthly, quarterly, semi-annually and annual vehicle inspections.
- Determine who, when, and how should pre-operation inspections be conducted.
- Notify operators what should be done if an unsafe condition or operating problem is discovered.

**CONTROLS AND OPERATION (Figure 2-1)**

**Power Keyswitch – Arrow A**

With the power keyswitch in the “OFF” position, the Traction Control System is powered down. This conserves battery energy by reducing the power draw when vehicle is not in use. Turning the power keyswitch or selector to OFF is highly recommended whenever vehicle is not in use. Always take the key out of the power keyswitch when leaving the vehicle.

**Direction Selector – Arrow B**

When the direction selector is in the vertical position, the vehicle’s direction signal is turned OFF or in neutral. Turn direction selector to the right from vertical position to move the vehicle in a forward direction (F). Turn direction selector to the left from vertical position to move the vehicle in a reverse direction (R). A warning buzzer sounds when in reverse.

**NOTICE: For some older vehicles Direction selector must be in the N or neutral position prior to turning on the power keyswitch, or a reset of the direction selector to neutral will be required before traction drive is enabled. See Section 4.11 CONTROLLER TROUBLESHOOTING.**



**Light Switch – Arrow C**

The light switch is a two-position switch. Move switch up to activate headlight and taillights, down to turn off

**Auxiliary Equipment Switch**

Not shown. A switch for auxiliary equipment will be located to the right of the light switch.

**Warnings/Operating Instructions - Arrow D**

Warnings/operating instructions must be read carefully before operating the vehicle. Promptly replace if removed or damaged. Contact Columbia ParCar for replacements.

**Horn Button**

Not shown. Located on the support panel to the left of the steering pump. Press button to sound the horn.

**Brake Pedal**

Not shown. To operate vehicle brakes, press brake pedal. Pressing the brake pedal also activates brake lights.

**NOTICE: Never rest your foot on brake pedal while operating the vehicle. This wears brake pads, creates drag and causes excess battery discharge.**

**Accelerator Pedal**

Not shown. The accelerator pedal controls the speed of the vehicle in the same manner as a conventional automobile. The pedal must be fully released when changing directions.

**CAUTION**

**To avoid injury, speed in reverse should always be kept at a minimum.**

**Parking Brake**

Not shown. All MVP models are equipped with a parking brake lever. To operate, pull up and back to engage; push forward and down to disengage.

**NOTICE: Do not operate the vehicle with the hand parking brake applied. Damage to the vehicle could result.**

**High/Low Speed Switch – Arrow E**

The switch is a two position toggle switch. The up position (rabbit) is for high speed and allows the vehicle to reach full speed. The down position (turtle) is a slower speed and is used for steep grades or off road in rough terrain. In this position the vehicle will produce more torque at the slower speed.

**Turn Signal/Hazard Warning Switch**

Not shown. If equipped, the turn signal / hazard warning switch is located on the steering column below the steering wheel. When lever is moved upward right turn signal turns on. When lever is moved downward left turn signal turns on. To turn off a signal move indicator lever back to center position. To operate the hazard warning lights pull outward on hazard bar. Moving the signal indicator lever to either of the turn signal positions will turn off the hazard lights.

**Seat Switch/Traction Interlock**

Not shown. Operator must be present in the driver seat for the vehicle traction drive to operate. A reset of the power system is required if an operator leaves the seat while the accelerator foot pedal is depressed.

**Wiper - Arrow F**

If equipped, the wiper has a 2 position switch located on the wiper motor. When turning wiper to the off position, it auto-positions to the right side of the windshield.

**Hour Meter Indicator**

Not shown. If equipped, the hour meter is located on the support panel in front of the steering pump. It indicates the total number of hours the vehicle has been operating.

**Charger Receptacle(s)**

The charger receptacle is located on the vertical panel adjacent to the driver's position. As shown, vehicles with dual battery packs will have receptacles and charger status displays with multicolored LEDs for each Delta Q charger.



The AC cord is plugged in here for battery charging. The charger is interlocked with the traction control system which powers down the vehicle during charging.

Always apply the parking brake when charging.

**NOTICE: Before removing the AC cord, be sure to check the Delta-Q remote LED status lights. See Section 4.7.1 CHARGER OPERATING INSTRUCTIONS.**

**Steering Wheel - Arrow G**

The steering wheel controls the path of the vehicle exactly the same as a conventional automobile wheel.

**Battery State Of Charge Meter – Arrow H**

This meter will display the battery state of charge. It is also located on the support panel in front of the steering wheel.



It is an analog gauge meter with an indicating needle and a colored background. It is a continuously reading meter. At rest with fully charged batteries the meter should read in the right white region.

When accelerating quickly, the needle will move to the left. If the needle continues past the green region into the very far left red region, it indicates that the batteries need recharging as soon as possible to avoid a shut-down of the vehicle.

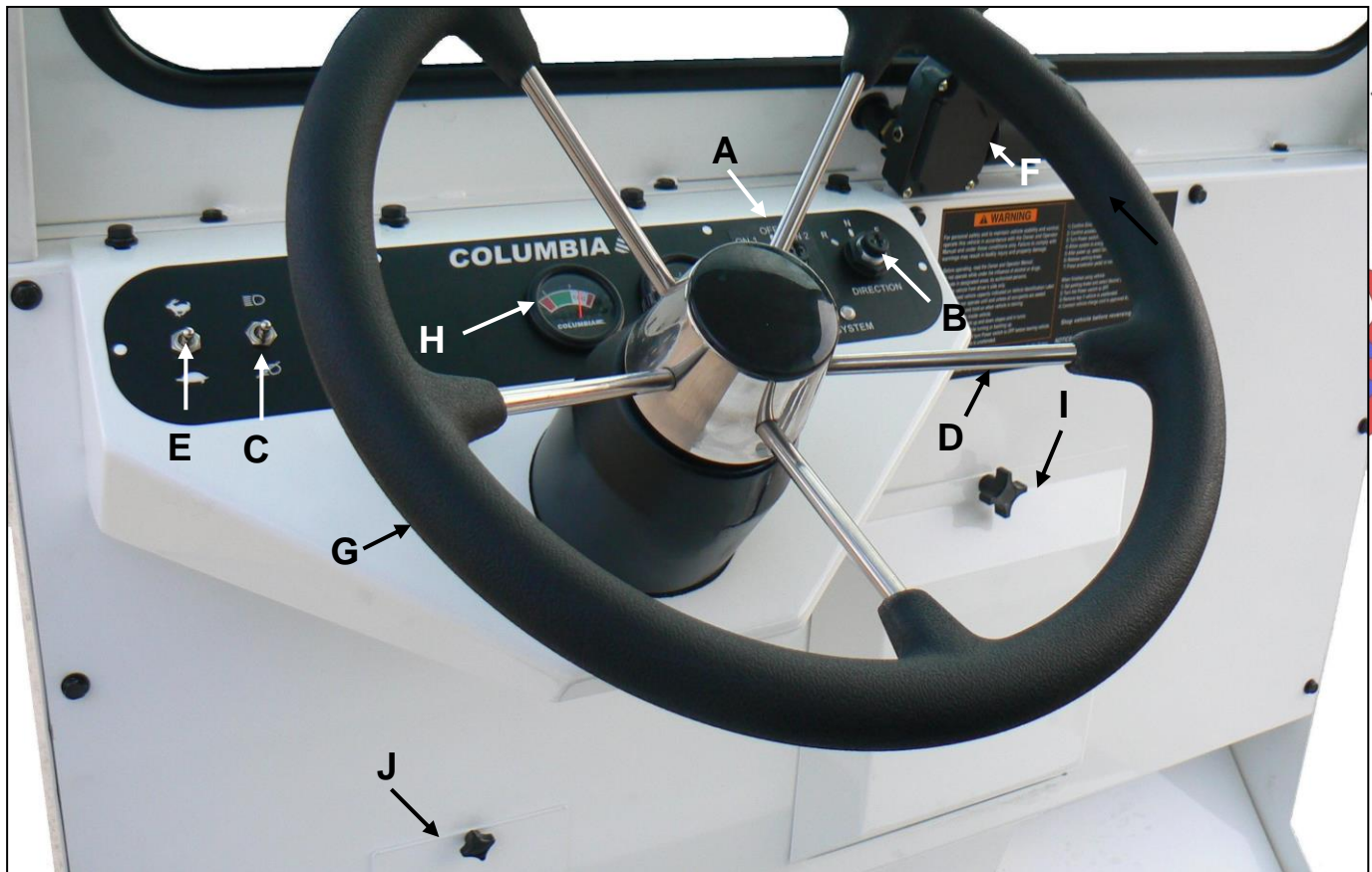
When decreasing speed, the needle will move to the right as electrical energy is being “regenerated” back into the batteries.

**Inspection Doors**

Arrow I has the master cylinder and Arrow J has the fuse block.

**PRE-OPERATION INSPECTIONS**

Each vehicle has been inspected and adjusted to factory specifications before delivery. Upon receipt of vehicle, perform an inspection of the vehicle. Also, before using the vehicle, there are checks that must be performed to ensure that it is in safe working order.



**Figure 2-1**

Columbia / ParCar OEM Parts  
 evtechnicalservices.com  
 TECHNICAL SERVICES

**⚠ WARNING**

Only trained maintenance professionals should service or repair this vehicle. Persons performing even simple repairs or service should have a working knowledge and experience in general electrical and mechanical repair. Follow all procedures and observe all warnings stated in this manual. Use caution and common sense.

**PRE-OPERATION CHECKLIST**

**⚠ CAUTION**

Before operating the vehicle always check the following items. Should any item malfunction or need adjustment. Do not operate vehicle until the problem has been corrected.

ITEM	PROCEDURE
Batteries	Fully charged or adequately charged to provide power for duration of operations.
	The AC cord is disconnected from the vehicle.
	Electrolyte level in each cell covers the top of cell plates. (See Section 4.12 for Single Point Battery Watering System information.)
	Batteries are secure and free of corrosion. All terminals and connections are tight.
	Battery tray is secure.
Tire Pressure	Inflated to the specifications labeled on the tire sidewall.
Lights, Horn and Reverse Buzzer	Turn lights on and make sure they illuminate.
	Press horn button to sound horn.
	Reverse buzzer sounds. (Operator seat must be occupied.)
Brakes	Brake pedal has firm pedal pressure with minimal travel.
	Parking brake has proper engagement and release.
Steering	Responsiveness and the absence of excessive free play.
Cargo	Load is secure, balanced and not top heavy.
Obstacles	Path of intended travel is free from obstructions.
Labels	All warning and operation labels in place.
Accelerator	Check for smooth operation.

**⚠ CAUTION**

Do not overload the vehicle. Never exceed Maximum payload as specified on the VIN Label.

Your safety and the safety of others depend on your safe operation and maintenance of this vehicle. Prior to operation, you, the operator, must be thoroughly familiar with this and all other sections of this manual.

Columbia / ParCar OEM Parts  
evtechnicalservices.com



**COLUMBIA** 

**Columbia ParCar Corp.**

**Service Manual**

**Section 3 - Maintenance**

**MAINTENANCE GUIDELINES**

**⚠ DANGER**

**Before performing any service on the vehicle, always turn Power keyswitch to OFF and remove. Turn Directional knob to NEUTRAL. Block tires.**

A comprehensive maintenance program is important for the safe, reliable operation of all Columbia ParCar vehicles. The recommended procedures described in this service manual are effective methods for performing periodic maintenance and repair. The maintenance procedures outlined in this manual are recommended when servicing the vehicle. Refer to maintenance checklist for frequency of service. Perform only those maintenance instructions described in this manual. If major repairs are needed, contact the local Columbia Dealer for assistance. Columbia Dealers have the technical experience, training and original Columbia Vehicle parts for the vehicle. Always use original Columbia Vehicle parts when servicing the vehicle.

**⚠ WARNING**

**No modifications or additions, which affect the mechanical or electrical integrity and the safe operation of the vehicle, shall be made without the written approval of the manufacturer. If such modifications are approved, the capacity, operation, and maintenance instruction markings shall be changed accordingly. In no case shall the safety factors be reduced below those specified in this manual or the manufacturers design factors, whichever is greater.**

This section explains how to perform maintenance procedures and use the maintenance checklist to determine how often you should perform each procedure. Follow the guidelines below to assure proper maintenance of your vehicle.

- Allow only trained maintenance personnel to maintain, repair, and inspect the vehicle.
- Before starting any repairs or maintenance, immobilize the vehicle by turning the key switch off, removing the key and setting the park brake.
- Disconnect both of the main battery leads before working on or disconnecting any electrical component or wire.
- Block the chassis with jack stands before working under a raised vehicle.
- Conduct vehicle performance checks in an authorized area where a safe clearance exists.
- Before starting the vehicle, follow the recommended safety procedures in Chapter 1.
- Avoid fire hazards and have fire protection equipment present in the work area.
- DO NOT use an open flame to check level or leakage of battery electrolyte.
- DO NOT use open fuel or flammable fluids for cleaning parts.
- Work in a properly ventilated work area.
- Regularly inspect and maintain in safe working condition the brakes, steering mechanisms, speed and directional

control mechanisms, warning devices, guards and safety devices.

- Inspect and maintain battery limit switches, protective devices, electrical conductors and connections in conformance with the manufacturer's recommended procedures.
- Keep the vehicle in a clean condition to minimize fire hazards and facilitate detection of loose or defective parts.

Before operating the vehicle inspect vehicle for damage, check operating controls (including Reverse Warning Alarm), check tires for proper inflation and test drive.

**NOTICE: Some procedures require the use of special tools. These special tools must be used when and where specified.**

**When performing Monthly, Quarterly, Semi-Annual or Annual maintenance, ensure that Daily and Weekly inspections are included.**

**The environment that the vehicle operates in can vary widely. Severe service operations will require the periodic maintenance recommendations to be adjusted to shorter time intervals. The following calendar is one example of how scheduling routine maintenance can be managed.**

**Periodic Service Calendar**

<b>JANUARY</b> Monthly	<b>FEBRUARY</b> Monthly	<b>MARCH</b> Quarterly
<b>APRIL</b> Monthly	<b>MAY</b> Monthly	<b>JUNE</b> Semi-Annual
<b>JULY</b> Monthly	<b>AUGUST</b> Monthly	<b>SEPTEMBER</b> Monthly
<b>OCTOBER</b> Monthly	<b>NOVEMBER</b> Monthly	<b>DECEMBER</b> Annually

**NOTICE: Daily maintenance is performed daily before operation of vehicle by owner or operator. Weekly maintenance is performed on a weekly basis to include all daily maintenance and is performed by the owner, operator or trained maintenance personnel.**

**SERVICE & MAINTENANCE SCHEDULE**

<b>Checklist – Tires &amp; Wheels</b>							
<b>Component</b>	<b>Procedure</b>	<b>Daily*</b>	<b>Weekly</b>	<b>Monthly †</b>	<b>Quarterly† (25 hours)</b>	<b>Semi-Annual† (50 hours)</b>	<b>Annual† (100 hours)</b>
Tires	Check for wear and damage	x					
	Pressure – per tire side wall	x					
	Damaged rims			x			
Front wheel alignment	Check & adjust as needed.					x	
Wheels	Check lug nuts	x					
	Wheel bearing, repack, replace as needed.						x
	Check axle nuts for tightness & torque					x	
Steering linkage	Check for excessive movement & that hardware is secure		x				

\* Service performed by Owner † Service performed by trained maintenance personnel

<b>Checklist – Operating Controls</b>							
<b>Component</b>	<b>Procedure</b>	<b>Daily*</b>	<b>Weekly</b>	<b>Monthly †</b>	<b>Quarterly† (25 hours)</b>	<b>Semi-Annual† (50 hours)</b>	<b>Annual† (100 hours)</b>
Steering & linkages	Check for free movement	x					
Accelerator	Check for free movement and return	x					
Brakes	Firm pedal pressure with minimum travel	x					
	Check parking brake adjustment	x	x				
	Check brake cables for damage			x			
	Clean & adjust brakes					x	
	Check brake fluid					x	
Directional Keyswitch	Check for smooth forward & reverse operation	x					
Lights, Horn, Wiper, Turn Signals	Operate properly	x					
Reverse Buzzer	Buzzer sounds	x					

\* Service performed by Owner † Service performed by trained maintenance personnel

Columbia / ParCar OEM Parts  
 evtechnicalservices.com  




Checklist - Electrical							
Component	Procedure	Daily*	Weekly	Monthly†	Quarterly† (25 hours)	Semi-Annual† (50 hours)	Annual† (100 hours)
Batteries	Check charge (fill cells prior to charging)	x					
	Check electrolyte level		x				
	Apply equalization charge to battery pack		x				
	Clean terminals and wash battery case		x				
	Test batteries					x	
Electrical wires	Check for tightness or damage		x				
Reverse warning buzzer	Check for operation (use keyswitch)	x					
* Service done by Owner		† Service done by trained maintenance personnel					

Checklist - Electric Motor							
Component	Procedure	Daily*	Weekly	Monthly†	Quarterly† (25 hours)	Semi-Annual† (50 hours)	Annual† (100 hours)
Operation	Test drive for proper operation	x					
Motor	Inspect brush length & remove carbon dust. Inspect & apply anti-seize to splines.						x
Chain/Belt	Check tension					x	
* Service done by Owner		† Service done by trained maintenance personnel					

Checklist - Fluids							
Component	Procedure	Daily*	Weekly	Monthly†	Quarterly† (25 hours)	Semi-Annual† (50 hours)	Annual† (100 hours)
Differential (See below)	Check for leaks			x			
	Check fluid level						x
Single Point Watering System	Add water		x			x	
	Check condition of tubing, couplers etc.			x			
	Clean filter screen					x	
* Service done by Owner		† Service done by trained maintenance personnel					

**DIFFERENTIAL FLUID LEVELS**

1. SPICER: Fill axle assembly with 12 ounces (360 ml) of Light Weight Gear Lubricant, SAE 30.
2. NKL: .Fill axle assembly with 600 ml. if draining, 800 ml if disassembling of Gear lubricant SAE #80 oil.

**LIFTING INSTRUCTIONS**

**⚠ WARNING**

Use extreme caution lifting or working on or around lifted vehicle. Vehicle should be lifted only when on a flat, hard and level surface.

DO NOT work under your vehicle unless it is firmly secured on jack stands.

When lifting the vehicle for service, use a sturdy lifting device such as a hoist, floor jack or hydraulic lift. ALWAYS block wheels and set parking brake of the vehicle to keep it from rolling. When using a lifting device, lift only on sturdy underbody parts, an example being the frame. When using a floor jack, lift only on sturdy underbody parts, an example being the frame or axle housing. Place jack stands under vehicle frame to support vehicle weight for added safety.

**NOTICE:** Be careful and watch for cables, linkages or wire harness.

**⚠ CAUTION**

If any vehicle is raised while loaded, check that the load is secured before lifting vehicle. Failure to do so could cause damage to vehicle, load or cause personal injury.

Before lifting, always chock tires. Use care to prevent tipping or rolling over.

Floor jacks, jack stands or hoists should be of sufficient rated weight capacity to hold the vehicle safely

**Hoist Lifts**

Lift the vehicle sufficiently from the floor, 10° to 25° angle, to allow the placement of jack stands and to support the weight of the vehicle during service.

To lift the front or rear, connect the lifting eyes/hooks to the right and left sides of the frame. Place jack stands under the frame at the right and left sides to allow working on the vehicle. When work is completed again lift and then remove jack stands and lower vehicle to the floor.

**Floor Jack**

Lift the vehicle sufficiently from the floor, 10° to 25° angle, to allow the placement of jack stands and hold the weight of the vehicle during service.

To lift the rear, place the floor jack under the rear axle housing and lift vehicle until jack stands can be placed under the frame at the right and left sides to allow working on the vehicle. Lower vehicle onto stands and remove floor jack. When work is completed reuse floor jack, lift and then remove jack stands and lower vehicle to the floor.

To lift the front, place the floor jack under the leaf spring retainer plate and lift. Place jack stands under the frame at the right and left sides to allow working on the vehicle. Lower vehicle onto stands and remove floor jack. When work is completed reuse floor jack, lift and then remove jack stands and lower vehicle to the floor.

**VEHICLE STORAGE**

**⚠ WARNING**

Turn key switch "OFF" and remove key during storage to prevent unintentional starting of vehicle.

DO NOT attempt to charge a battery that is frozen or if battery case is excessively bulged. Properly dispose of battery, because frozen batteries can explode.

**⚠ CAUTION**

Batteries in a low state of charge will freeze at higher temperatures than fully charged batteries.

Electric vehicles stored over six (6) to eight (8) weeks must be protected to maintain battery life. Several guidelines should be observed when storing your electric vehicle.

- Fully charge batteries. With electrolyte full in all cells, store batteries in as cool a place as possible. If stored above 50 degrees F (10° C), check state of charge every four (4) to six (6) weeks and charge as necessary to maintain 1.250 to 1.270 specific gravity. If vehicles are stored in temperatures below 40° F check state of charge every fifteen (15) to eighteen (18) weeks. Use the table below to determine freezing point of battery and maximum recommended storage temperature. Refer to Section 9 – Batteries in this manual for a charging procedure. Remove battery pack negative cable.
- Wash off any corrosion around the terminals with a solution of baking soda and water. Do not allow this solution to enter batteries.
- Store vehicle in a cool dry place to prevent battery discharge.
- Maintain tire pressure at manufacturer's recommendation imprinted on tire sidewall.
- Grease front suspension and continue quarterly lubrication during storage period. Refer to periodic maintenance in the beginning of this section.
- Clean vehicle body, seats, battery compartment and vehicle underside.
- Do not engage park brake. Block wheels to prevent movement.



SPECIFIC GRAVITY & FREEZE POINTS					
Specific Gravity	1.250	1.225	1.200	1.117	1.110
Electrolyte	F C	F C	F C	F C	F C
Freeze Point	65 -54	-39 -39	-18 -28	-2 -19	+17 -8

**RETURNING VEHICLE TO SERVICE:**

- Reconnect battery negative terminal.
- Fully recharge batteries.
- Check tire pressure and readjust if necessary.
- Perform initial maintenance per periodic maintenance in the beginning of this section.
- After the batteries have been fully charged, connect the single point watering system to its water supply for 3-5 seconds, then disconnect regardless of whether or not the batteries are completely full.
- Return the vehicle to its regular service.
- Place the vehicle back into its regular watering schedule (waiting at least 1 week until next watering).

**TRANSPORTING A VEHICLE**

**NOTICE: Never tow a vehicle behind an auto or truck unless on an approved trailer.**

When trailering a vehicle over long distances or on the highway observe the following:

- Use trailers specifically designed to carry your Columbia ParCar vehicle that meets all federal, state and local requirements.
- Secure vehicle to the trailer following trailer manufacturer’s instruction.
- The key should be removed from the vehicle, the parking brake firmly locked, and the wheels blocked.
- On vehicles equipped with high or wide additions or accessories be certain they are secured properly to prevent loss or damage while trailering.

**⚠ CAUTION**

**Increased transporting speed adds undue stress to windshield, cab or suntop and will increase chance of loss, damage, accident or injury.**

**Use care when transporting on windy days. Example: A 60 MPH speed into a 40 MPH head wind is equal to traveling at 100 MPH. Golf and Industrial vehicles are not rated to withstand this level of stress and parts could be blown from top or cab, causing accident or injury.**



**COLUMBIA** 

**Columbia ParCar Corp.**

**Service Manual**

**Section 4 - Troubleshooting**

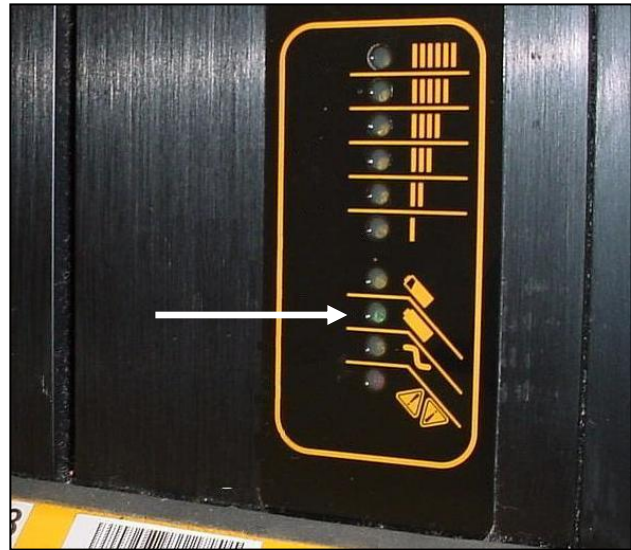
**⚠ WARNING**

Always turn Power keyswitch to OFF, Directional keyswitch to Neutral, remove Power keyswitch, block tires and disconnect the battery negative (-) cable before performing any vehicle service to avoid accidental startup of vehicle and possible injury.

**PRE-TROUBLESHOOTING STEPS**

Before troubleshooting a vehicle for any problem or symptoms, certain steps must be followed.

- Ensure the vehicle is safe for service. Visually inspect for any obvious signs of hazards such as sharp edges in the body or other parts, open wire insulation or wire connections, or discolored parts of the vehicle indicating heat or chemical presence.
- Record the VIN. This number is necessary to obtain technical help or support, submit warranty, and is essential in order to understand completely the vehicle that is being serviced.



**BATTERY TESTING**

The first step in servicing any electric vehicle that is not operating properly is to completely test the batteries. The batteries are the source of power for the vehicle drive and auxiliary systems, therefore are the most integral part of the electric vehicle troubleshooting. Battery testing should be done as follows and in the order as follows

Inspect/Test Condition	Corrective Action
Perform a visual examination of batteries and connections. Examine for signs of corrosion and clean/or replace any affected terminals or cables.	The batteries can be cleaned by hose washing with a standard garden hose or with a soft bristle brush (ensure battery caps are present and tight before washing batteries).
Examine the battery hold-down. If the material from the hold-down has been dissolved by the sulfuric acid in the batteries, the hold down can act as a drain on the battery pack.	Replace the hold-down if it appears damaged.
Test each battery with a VOM (volt-ohm meter). With VOM set to a scale able to read DC volts at up to 100 volts (or greater), check each battery individually, and test the entire pack together.	Place the VOM probes on the battery positive and negative post of each battery. Write down the reading from each battery. Each should contain at least 6.0 volts and no battery should be more than .5 volts lower than the highest reading. If any battery tests low on charge, change the battery individually with an auxiliary charger or the entire pack with the onboard Delta Q charger (allow vehicle to charge until the green charger light is illuminated, indicating full charge. See Figure 4.1). If one or more batteries still test low, the battery should be tested individually and replaced as necessary. <i>NOTE: It is recommended that all batteries in a system be changed together to ensure the batteries are the same brand, vintage, and service life.</i>
Test each battery cell with a battery hydrometer.	Any battery or battery cell that tests low should be fully charged and then rechecked. If the cell continues to test low with a hydrometer, the battery should be replaced. See note above.
A battery may test good with a voltage or hydrometer test when no load is being drawn from it. Test using a battery load tester.	A battery must be able to produce 45 minutes of capacity when tested at 55 amp draw after a complete recharge cycle. A battery that is not able to produce this capacity should be replaced. See note above.

**TROUBLESHOOTING SPECIFIC COMPLAINTS**

Troubleshooting is a matter of investigation and deduction based on the symptoms and the possible causes. Recording every possible solution to every possible cause would be impossible, but this troubleshooting section is designed to assist in solving issues that may arise in the service life of an electric vehicle.

The main key problems encountered with the vehicle(s) are:

- Vehicle will not move; forward or reverse
- Vehicle operates slowly
- Vehicle drives in forward or reverse only
- Vehicle drives but operation is jerky or inconsistent
- Vehicle power cuts out



**Figure 4-2**

**NOTICE: Always follow troubleshooting guide in exact sequence as listed. Performing tests out of sequence will cause inaccurate results and lost time in diagnosing electrical system problems-**

**VEHICLE WILL NOT MOVE; FORWARD OR REVERSE**

Before attempting to service a vehicle, complete the pre-service inspection and fully test the batteries as described on the previous page. Set the vehicle power keyswitch to “ON”. The green status light (Figure 4-2) on the controller will show one of three conditions; steady off, steady on, or flashing.

*In some lighting situations it is difficult to determine the condition of the fault light. Ensure an accurate reading of the light by shading it.*

Fault Code	Condition	Corrective Action
Fault code light steady OFF.	The controller is not getting the proper voltage or the controller has failed internally.	<ol style="list-style-type: none"> <li>1. Check to make sure the controller has a good battery negative connection at the B-terminal. Attach the black lead of the VOM to the B- terminal and attach the red lead to the battery pack positive post. On DC volts scale, full battery pack voltage should be observed. If not, check or replace the connections and cable between the main battery pack negative post and the controller B- post. If correct voltage is present, disconnect the 16 pin wire connection from the controller. Set main power switch to ON. Insert the black lead to the B-terminal on the controller and the red lead to the red #1 wire of the 16 pin connector. Full voltage should be observed.</li> <li>2. If voltage is present, reconnect the 16 pin plug connector to the controller and ensure the wires are fully seated in the back of the plug. If there is system voltage between B- post and the #1 pin, and the controller light does not illuminate, the controller has failed internally and must be replaced.</li> <li>3. If there is no voltage present between the #1 pin and the B- terminal, and B- terminal has a good connection to battery pack negative, the red #1 wire circuit is not energizing properly. Make sure the charger positive (red) wire is connected to the main battery pack positive terminal, and then check the table below.</li> </ol>

Columbia / ParCar OEM Parts  
evtechnicalservices.com



VOM Black Lead	VOM Red Lead	Pass	Fail	Correction Action - Check
Main battery negative post	Green charger interlock wire	Full system voltage	Low or no voltage	Charger red lead to battery positive connection. Charger output wires for damage
Main battery negative post	Red wire #15 side of 1 amp fuse connector	Full system voltage	Low or no voltage	Red wire #15 connection to green charger interlock wire Red wire #15 for damage
Main battery negative post	Red wire #16 side of 1 amp fuse connector	Full system voltage	Low or no voltage	1 amp fuse or fuse connections
Main battery negative post	Red wire #28 at power key switch	Full system voltage	Low or no voltage	Red wire #18 for damage Red wire #28 to red wire #16 connection (at optional low/run connection)
Main battery negative post	Red wire #17 at solenoid positive tab	Full system voltage	Low or no voltage	Wiring from power key switch for damage/poor connections
Main battery negative post	Red wire #1 at 16 pin connector	Full system voltage	Low or no voltage	Wiring from power key switch for damage/poor connections

VEHICLE WILL NOT MOVE; FORWARD OR REVERSE (continued)		
Fault Code	Condition	Corrective Action
Fault code light steady ON	Indicates the controller is powered up and ready to perform. If the vehicle fails to operate with the fault code light in the steady on condition, it is likely the controller is not receiving the correct input from the drive system, or a mechanical fault has occurred.	<ol style="list-style-type: none"> <li>1. Check to make sure the parking brake is releasing and the vehicle will not roll when pushed on a level surface.</li> <li>2. Check for other mechanical failures such as stripped hubs or anything that would prevent the vehicle from being able to operate. Make sure a direction of travel is selected (the vehicle will not attempt to drive while set to Neutral). Check the inputs of the electrical system by using the Computer Diagnostics Utilities (Columbia Part No. 30001-04) or the handheld calibrator (Columbia Part No. 30003-04). See the following procedures.</li> </ol>

**TROUBLESHOOTING WITH PCPAK**

With the vehicle power system off, connect the PCPak (computer diagnostic utility) and then turn the vehicle power on.

1. Open the connection between the controller and the PCPak utility. On the left side of the screen, select the "test" section under the "traction" pull down. This screen will display the inputs the controller is observing at that time (Figure 4-3).

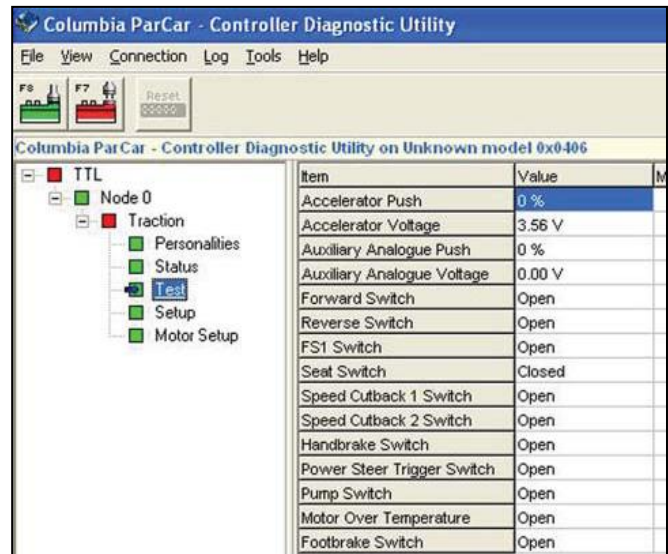


Figure 4.3

2. With the Forward / Reverse knob set to Neutral, slowly press the accelerator pedal. The "Accelerator Push" value should rise in value from 0-100% smoothly as you press the pedal (Figure 4-4). If the value does not change, the controller is not receiving input from the accelerator control device (potentiometer or linear accelerator device). Check all cable and wire connections regarding the accelerator control device. If the value does rise, but not to 100%, adjust the accelerator cable that attaches to the accelerator device.

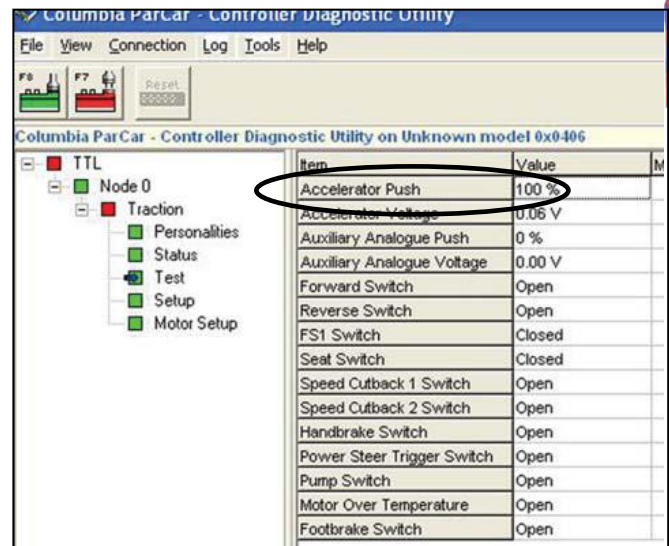
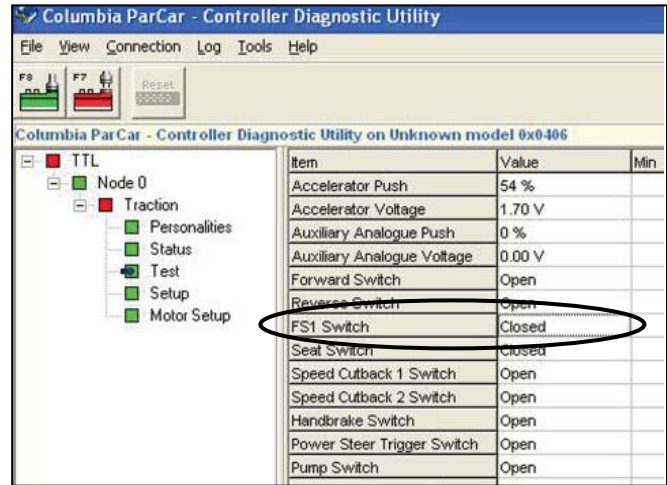


Figure 4.4

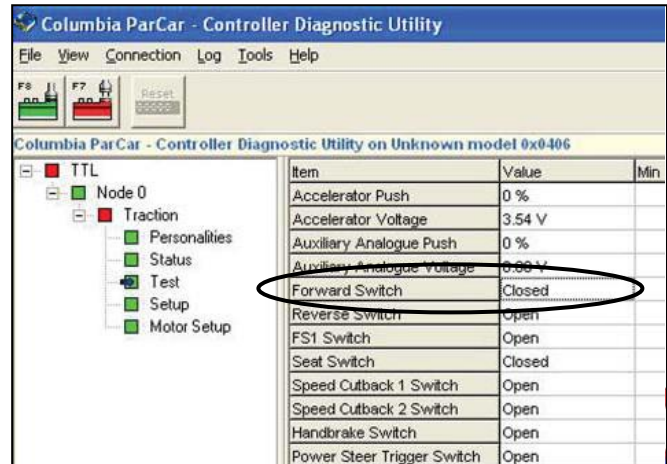
**TROUBLESHOOTING WITH PCPAK (continued)**

3. Check the FS1 Switch input on the same screen. With the accelerator at rest, the value for the FS1 Switch should read “open”. When the accelerator pedal is pressed, the value should change to “closed” (Figure 4-5). If the value fails to close, check the FS1 wiring circuit and test the switch with a VOM. Check the wiring back to the controller (Pin 4).



**Figure 4-5**

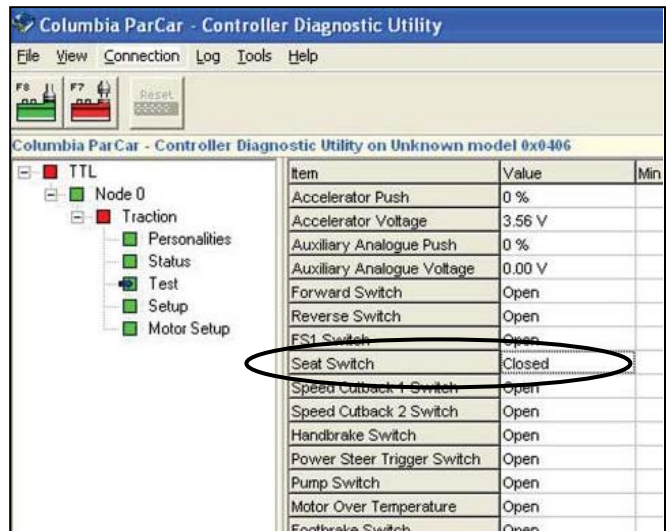
4. Check the direction input to the controller. Observe the value of the “Forward Switch” item while turning the direction selection knob to “Forward” and to “Neutral”. The switch should read “open” when the knob is in neutral and “closed” when in forward (Figure 4-5). Do the same in reverse by monitoring the “Reverse Switch” item and value. If the switch fails to close in either direction, check the switch with a VOM and the wiring back to the controller (Pin 2 for Forward and Pin 3 for Reverse).



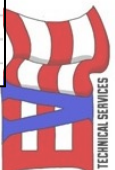
**Figure 4-6**

5. Check the “Seat Switch” item and value (Figure 4-6). For vehicles equipped with a seat switch, the value should read “open” when the operator seat is not occupied, and “closed” when the operator seat is occupied. If the switch fails to close, check the wiring from the B- post of the controller to the seat switch, test the seat switch with a VOM, and check the wiring back to the controller (pin 5). For vehicles without a seat switch, the value should read “Closed”. If the switch does not register as closed, check the black 5 wiring from the B- post of the controller to controller plug (pin 5).

If the vehicle is receiving the correct inputs and fails to operate, contact Columbia tech support for further assistance.



**Figure 4-7**





**TROUBLESHOOTING WITH THE HANDHELD CALIBRATOR**

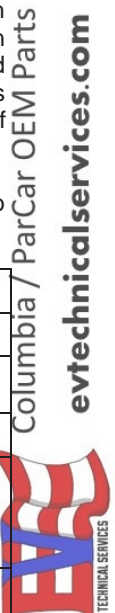
- Connect the handheld calibrator to the vehicle and enter the “Read-Only” mode (RON). Scroll down by pressing “Select” button until you reach the “19” menu (location 19.01). The “Test” light on the left side of the calibrator will illuminate when the “19” menu is selected. This menu shows the inputs the controller is observing at that time. At 19.01, the calibrator displays the “Accelerator Push” in percentage.
- With the Forward / Reverse knob set to Neutral, slowly press the accelerator pedal. The “Accelerator Push” value should rise in value from 0-100% smoothly as you press the pedal. If the value does not change, the controller is not receiving input from the accelerator control device (potentiometer or linear accelerator device). Check all cable and wire connections regarding the accelerator control device. If the value does rise, but not to 100%, adjust the accelerator cable attached to the accelerator device.
- Next, check the FS1 Switch input by scrolling to the 19.07 location. At rest, the value for the FS1 Switch should read open, or (3.OP). When the accelerator pedal is pressed, the value should change to closed, or (3.CL).

If the value fails to close, check the FS1 wiring circuit and test the switch with a VOM. Check the wiring back to the controller (Pin 4).

- Check the direction input to the controller. Observe the value of the “Forward Switch” item at location 19.05 while turning the direction selection switch to “Forward” and to “Neutral”. The switch should read open (1.OP) when the switch is in neutral and closed (1.CL) when in forward. Do the same in reverse by monitoring the Reverse Switch at location 19.06 and value. If the switch fails to close in either direction, check the switch with a VOM and the wiring back to the controller (Pin 2 for Forward and Pin 3 for Reverse).
- Check the Seat Switch at location 19.09. For vehicles equipped with a seat switch, the value should read open (5.OP) when the operator seat is not occupied, and closed (5.CL) when the operator seat is occupied. If the switch fails to close, check the wiring from the B- post of the controller to the seat switch, test the seat switch with a VOM, and check the wiring back to the controller (pin 5). For vehicles without a seat switch, the value should read closed (5.CL). If the switch does not register as closed, check the black wire #5 wiring from the B- post of the controller to controller plug (pin 5).

If the vehicle is receiving the correct inputs and fails to operate, contact Columbia tech support for further assistance.

<b>VEHICLE WILL NOT MOVE; FORWARD OR REVERSE - LED DIAGNOSTIC GUIDE</b>	
<b>Green LED Flashes</b>	<b>Check/Test</b>
1 Flash	Check all wire connections for good connection and free of corrosion. Call Columbia Technical Support if problem persists.
2 Flash	Perform steps 1 - 5 under <i>Troubleshooting with Handheld Calibrator</i> above.
3 Flash	Check all wire connections. Disconnect all electrical accessories (strobe lights, heaters, etc.) External or internal wiring faults will cause controller 3 Flash. Eliminate all “non-controller” sources first. Plug in calibrator and read location 13.10 fault code for more precise fault cause(s). Call Columbia Technical Support if problem persists.
4 Flash	Bench test 24 volt main solenoid. Check all wiring. Plug in Calibrator and read location 13.01 for more precise fault cause(s).
5 Flash	Motor stall fault. Check motor for damage. Plug in Calibrator and read location 13.10 for more precise fault cause(s).
6 Flash	Accelerator fault. Check all wiring pertaining to the accelerator (pot box) switch. Perform steps 1, 3 and 4 under <i>Troubleshooting with Handheld Calibrator</i> above. Check the Pot box with an analog ohmmeter.
7 Flash	Low or high battery voltage. Check battery voltage with a voltmeter. If battery voltage drops below 15 volts (24 volt system) or 32 volts (48 volt system), the controller will shut down. Read pack voltage both stationary and under hard acceleration if possible. If voltage is good while static, but drops significantly while accelerating, weak or damaged batteries may be the cause.
8 Flash	Over temperature cutout. Call Columbia Technical Support.
9 Flash	Out of range. Call Columbia Technical Support.
10 Flash	Bench test 24 volt main solenoid. Check all wiring. Plug in Calibrator and read location 13.01 for more precise fault cause(s).



**VEHICLE DRIVES SLOWLY**

- Check for all physical/visual signs of damage, low tire pressure or jammed linkages.
- Check for brake drag by turning vehicle power off, releasing parking brake, and attempting to roll vehicle a short distance.
- Plug in the Handheld Calibrator and check 5.01, 6.01 and 7.01 for appropriate values (maximum speed settings).
- Perform step 2 in *Troubleshooting with Handheld Calibrator*.
- Check for weak, discharged or damaged batteries, or poor connections.

**VEHICLE DRIVES IN FORWARD OR REVERSE ONLY**

- Perform step 4 in *Troubleshooting with Handheld Calibrator*.

**VEHICLE DRIVES BUT OPERATION IS JERKY OR INCONSISTENT**

- Check speed switch carefully with analog ohmmeter for gradual, smooth resistance sweep.
- Check motor brushes. Replace if bad or worn (Figure 4-8).
- Call Columbia Technical Support if problem persists. Have the following information ready:
  - VIN
  - Vehicle Checksum (19.15)
  - Direction of travel where the operation is "jerky"
  - Speeds at which vehicle jerks.

**VEHICLE POWER CUTS OUT**

The fault for a vehicle that exhibits a cut out symptom can only be diagnosed while the vehicle is in a fault condition.

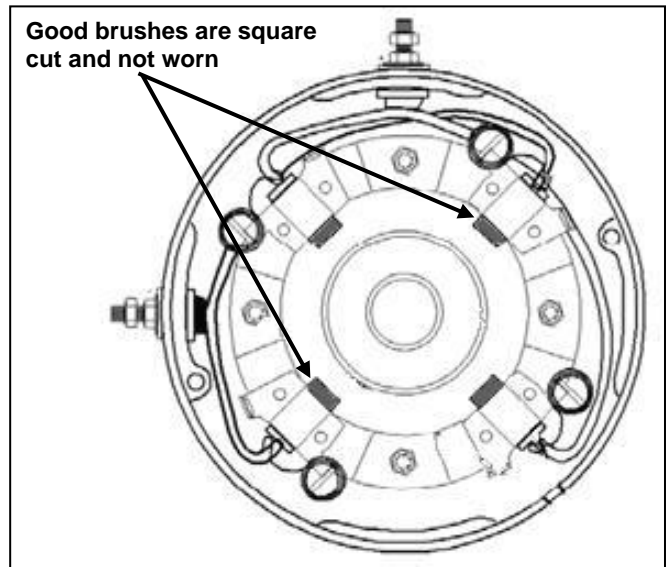


Figure 4-8

**FLASH CODES AND CORRECTIVE / INVESTIGATIVE ACTION**

Flash Code	Description	Action	Handset ID fault number	Calibrator reference loc	Correction – If fault does not clear
0 Flash (Light does not illuminate or light turns on and then back off.)	Internal Mosfet failure	Disconnect any electrical accessories and retry	25 / 26	13.01	Controller replacement required, contact Tech Support
	Pin 1 Circuit Fault	Trace current from battery positive to Pin 1	-	-	Replace failed connection, component, or wiring.
	Contactor Circuit fault	Trace current to solenoid and contact connections	-	-	Replace failed connection, component, or wiring.
Flash 1	Personality out of range	Check personality Checksum	81 /71	51.91	Controller replacement required, contact Tech Support
Flash 2	Seat Switch Fault	Check seat switch & seat switch circuit	7	80.91	Repair or replace failed connection or component
	Accelerator not at rest when direction selected	Ensure Accelerator Pedal returns to 0 (rest) position	8 or 9	19.01/19.07	Repair or replace failed connection or component
	Two directions selected	Ensure Direction Key switch is functioning properly	10	19.05/19.06	Repair or replace failed connection or component
	Forward or reverse selected at power up	Ensure Direction Key switch is functioning properly	11	19.05/19.06	Repair or replace failed connection or component
	Speed Switch out of range	Check speed switch range	11	19.01/19.02	Repair or replace failed connection or component
	FS1 not open with pedal up	Ensure Pedal returns to 0 and microswitch is functioning properly	11	19.07	Repair or replace failed connection or component
	Controller pins are cross - shorted	Check wire harness connector pins for good connections	Various	19.01 - 19.09	Repair any faulty connections
Flash 3	Auxiliary wiring short	Disconnect auxiliary electrical components and retry	-	13.01	Controller replacement required, contact Tech Support
	Armature Short Detected	Clean and Check motor and wiring for faults	23	13.01	Motor replacement may be required, contact Tech Support
	Internal controller fault	Disconnect auxiliary electrical components and retry	27	13.01	Controller replacement required, contact Tech Support
Flash 4	Contactor failed or stuck	Bench test contactor	91	13.01	Replace Solenoid, If good - Controller replacement required, contact Tech Support
	Contactor Failed or contactor wiring fault	Bench test contactor and test contactor wiring	20	13.01	Repair or replace failed connection or component
	Motor open circuit or brushes fault	Clean and Check motor and wiring for faults	22	13.01	Motor replacement may be required, contact Tech Support
Flash 5	Motor stall detected	Clean and Check motor and wiring for faults - review application	15	13.01	Motor replacement may be required, contact Tech Support
Flash 6	Input wire disconnected	Check wiring to speed switch & FS1	4	13.01/19.01/10.91	Repair or replace failed connection or component
	Speed switch out of adjustment	Check speed switch range	11	13.01/19.01/19.02	Repair or replace failed connection or component
	Pedal depressed at start up	Ensure Accelerator Pedal returns to 0 (rest) position	8 or 9	13.01/19.01/19.07	Repair or replace failed connection or component

Flash Codes and Corrective / Investigative Action (continued)

Flash Code	Description	Action	Handset ID fault number	Calibrator reference loc	Correction – If fault does not clear
Flash 7	Battery voltage low	Check Static battery voltage and voltage while operating	12 / 13 or 16	13.01/15.01	Check to see if voltage drops below 32 volts, charge / replace batteries
	Battery voltage high fault	Check Static battery voltage and voltage while operating	12 / 13 or 16	13.01/15.01	Check to see if voltage rises above 63 volts in while operating, see SB - 12-07
	Capacitor voltage is too high	Check Static battery voltage and voltage while operating	14	13.01/15.02	Contact tech support with reading from 15.02
8 Flash	Over Temperature cut - out	Review application and allow vehicle to cool	1	13.01/18.01	Contact Tech Support
	Current Cut - Back	Review application and allow vehicle to cool	3	13.01/18.01	Contact Tech Support
Flash 9	Internal motor tripped	Disconnect any electrical accessories and retry	2	-	Controller replacement required, contact Tech Support
10 Flash	Contactor Coil Disconnected	Bench test contactor and test contactor wiring	-	13.01	Contactor or Controller replacement may be required, contact Tech Support
	Value out of range	Check personality Checksum	43	13.01/51.91	Controller replacement may be required, contact Tech Support
	Internal controller fault	Disconnect any electrical accessories and retry	34	13.01	Controller replacement may be required, contact Tech Support

**COMPONENT TROUBLESHOOTING**

In addition to the problems/cause/solutions listed in this section, individual sections also contain some testing and problem solution for individual components. Check the appropriate section first, and if the information is not found, check the following when a component is causing a problem:

**Battery Discharge Indicator (BDI)**

- Fuse failed. Check fuse and replace if failed.
- Open wiring or failed connection. Check wiring and connections.
- Inoperable BDI gauge. Replace gauge.
- Weak or failed batteries. Test batteries and charge as necessary.

- Open wiring or failed connection. Check wiring and connections.
- Inoperable reverse buzzer. Replace buzzer.
- Weak or failed batteries. Test batteries and charge as necessary.
- Controller set wrong. Check controller setting using hand held. Reset if necessary.

**Brake Lights and Auxiliary Switch**

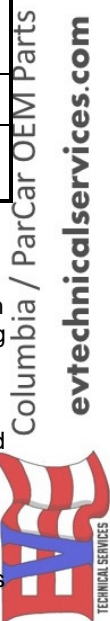
- Fuse failed. Check fuse and replace if failed.
- Open wiring or failed connection. Check wiring and connections.
- Bulb failed. Replace bulb.
- Misadjusted or inoperable brake light switch. Check switch adjustment, replace switch if necessary.

**Head Light & Tail Light**

- Fuse failed. Check fuse and replace if failed.
- Open wiring or failed connection. Check wiring and connections.
- Bulb burnt out. Replace bulb (Headlight only source locally).
- Failed power key switch. Test and replace contactor as necessary.
- Inoperable switch. Replace switch.

**Reverse Beeper**

- Fuse failed. Check fuse and replace if failed.



**Power Outlet**

- Fuse failed. Check fuse and replace if failed.
- Open wiring or failed connection. Check wiring and connections.
- Inoperable power outlet. Replace power outlet.

**Brake Light**

- Fuse failed. Check fuse and replace if failed.
- Open wiring or failed connection. Check wiring and connections.
- Bulb burnt out. Replace bulb.
- Failed power key switch. Test and replace contactor as necessary.

**BRAKES****Slow Or Incomplete Release Of Brakes**

- Shoes and linings. Shoes improperly adjusted. Shoes are self-adjusting; check parts for wear. Shoes distorted or incorrect. Replace with new parts.
- Mechanical parts. Damaged or weak return springs- replace.
- Cables and linkage sticking, dirty or corroded. Lubricate with a commercial solvent like WD40, PB Blaster, etc. Make sure not to contaminate brake pads with solvent.

**Wheel Bearings**

- Damaged or contaminated- replace.
- Grabbing or pulling- replace.

**Air In Hydraulic Lines**

- . Bleed hydraulic lines.

**Severe Reaction To Pedal Pressure And Uneven Stopping**

- Shoes and linings. Shoes improperly adjusted. Shoes are self-adjusting; check parts for wear. Shoes distorted or incorrect. Replace with new parts.
- Mechanical parts. Damaged or weak return springs- replace. Cables and linkage sticking, dirty or corroded. Lubricate with a commercial solvent like WD40, PB Blaster, etc.
- Drums. Drums are thin (expanding when hot); oversize (beyond .030") of original specification – replace. Scored, out-of-round – replace.

**Brakes Squealing, Clicking Or Scraping Noises**

- Shoes and linings. Shoes twisted, distorted, incorrect or broken – replace. Linings worn out, glazed, loose or contaminated – replace.
- Mechanical parts. Damaged or weak return springs- replace. Backing plate loose or failed – replace.
- Drums. Drums are thin (expanding when hot); oversize (beyond .030") of original specification – replace. Scored, out-of-round – replace

**CAB HEATER**

The optional cab heater is equipped with a three position toggle switch. The CENTER position is off. To activate the heater and fan, move the switch to the UP position. To activate the fan only place the switch in the DOWN position.

**NOTICE: If the toggle switch is in the Fan/Heat position and no heat is occurring a circuit reset is required On a side panel there is a 3/8" hole. Inside is a reset tab. Using a non-conductive device push the tab to reset the circuit.**



**Columbia ParCar Corp.**

**Service Manual**

**Section 5 – Accelerator & Brake System**

**VEHICLE SERVICE**

When servicing the electric Columbia Industrial/Commercial vehicle always observe the following:

**⚠ WARNING**

**Always turn Power keyswitch to OFF, Directional knob to Neutral, remove Power keyswitch, block tires and disconnect the battery negative (-) cable before performing any vehicle service to avoid accidental startup of vehicle and possible injury.**

**ACCELERATOR PEDAL**

Accelerator pedal maintenance consists of periodic inspection. No lubrication or adjustment is necessary.

The accelerator pedal works in conjunction with the linear accelerator and the Sevcon controller to adjust and control vehicle direction and speed.

All adjustments are made using the handheld Calibrator. See *Section 4-Troubleshooting*.

**REAR HYDRAULIC BRAKE SYSTEM**

The hydraulic brake system utilizes a combination of mechanical and hydraulic components and is equipped dual wheel rear drum brakes.

A mechanical brake pedal/linkage assembly is utilized to actuate a master cylinder. The master cylinder creates hydraulic pressure which operates the brakes. Hydraulic brake systems require a separate mechanical parking brake. A hand operated parking brake, mechanical linkage and cables are utilized to mechanically lock the rear brakes for parking.

**⚠ CAUTION**

**Do not handle hydraulic system parts with greasy hands or permit parts to come in contact with oil or grease. Grease or oil will damage the rubber parts.**

**Periodic Brake Inspection**

Intervals between brake service and inspection may vary depending on driving habits, type of driving, road and climate conditions, and vehicle load.

**⚠ CAUTION**

**Periodic brake inspection is required to prevent potential accident or injury and vehicle damage.**

Periodic inspection should always include the following:

1. With vehicle stationary, depress the brake pedal. Pedal should not travel in excess of 2-1/2" as measured from floor board. If pedal travels in excess of 2-1/2" before resistance is felt, or if pedal feels spongy and soft, repair or maintenance is required.
2. Inspect brake master cylinder and adjoining brake lines for signs of fluid leakage. Remove master cylinder cover. Fluid must be clear and fluid level should be within 1/4" of cylinder top (with vehicle on level ground).
3. Check parking brake operation. Parking brake hand lever should travel no more than 3-1/2" upward when engaged. Check that ratchet mechanism automatically holds parking brake handle in up position. Make sure release button on handle frees the parking brake lever and that lever returns to full down (released) position.
4. Operate vehicle on level ground, applying brakes to ensure that both rear brakes apply equally. Check that excessive force is not required to apply brakes. Excessive force required to apply brakes could indicate malfunctioning brake system or excessive wear to brake shoes.

**Annual Brake Inspection**

See Figure 5-1 Spicer Hydraulic Brake Assembly. See Figure 5-4 for NKL Hydraulic Brake Assembly.

**⚠ WARNING**

**To perform this service, raise vehicle using floor jack and safely support it with jack stands positioned under main frame tubes. See Section 3 Maintenance - Lifting Instructions.**

1. Perform steps 1 & 2 under *Rear Drum Brake Disassembly*.
2. Inspect drum for excessive or uneven wear. Refer to *Brake Drum Service*. Look for cracks radiating from stud holes.
3. Inspect wheel cylinder area for fluid leakage. Also inspect the axle and axle tube area for leakage from the axle bearing
4. Inspect brake shoes for fluid contamination, damage or excessive wear. Measure brake lining thickness at the narrowest point. Lining should measure no less than 1/16" (1.6 mm). If worn beyond this, brake shoes must be replaced. See *Rear Drum Brake Disassembly*.
5. Wash brake assemblies removing mud, brake shoe debris, and dirt. Apply white lithium grease to contact points between brake shoe and brake back plate. Remove excess grease to prevent brake shoe contamination.



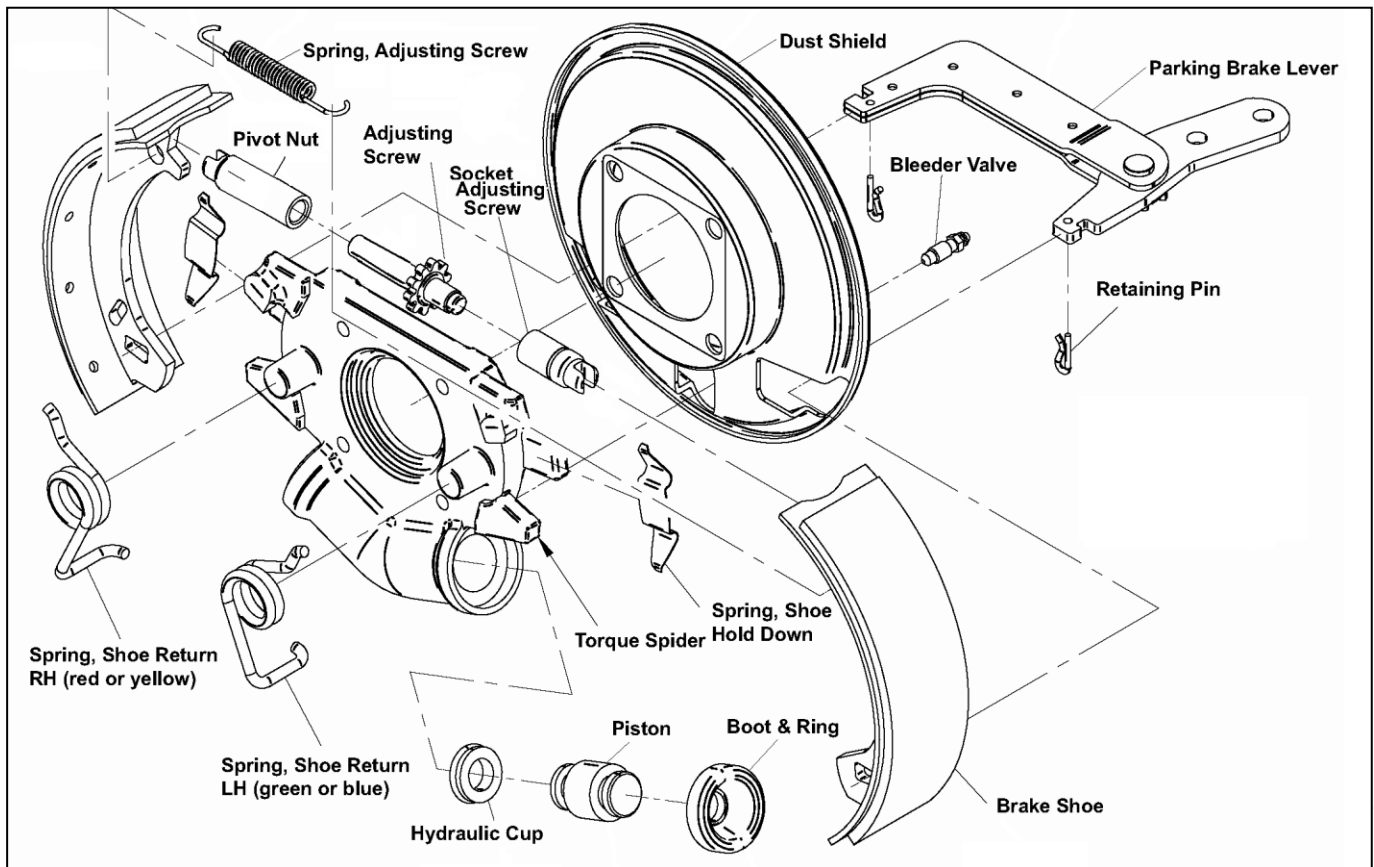


Figure 5-1 Driver Side (Spicer Axle)

Columbia / ParCar OEM Parts  
 eotechnicalservices.com

**CAUTION**

Do not use compressed air to blow dust from brake assembly. Brake dust contains potentially harmful contaminants.

- Always replace any springs that appear stretched or deformed.
- Never use petroleum based cleaners or lubricants on hydraulic brake parts as they will contaminate the brake fluid.



6. Perform steps 5-8 under *Drum Brake Reassembly*.

**Drum Brake Disassembly**

**NOTICE:** It is not recommended to remove the hydraulic brake assembly from the axle for repair or service.

**NOTICE:** Do not mix parts from left and right brake assemblies as they may differ.

- Before removal of existing parts, note location of springs and other parts for correct reassembly.
- Always use a brake spring tool to remove and install springs.
- Always lay out brake shoes and other parts in order removed. Reinstall in same order.
- Always replace brake shoes that have been contaminated with oils or lubricants.

1. Engage the parking brake. Remove rear wheel/tire assembly. Repeat for other rear wheel.
2. Release parking brake and remove brake drum.
3. Use a brake spring tool and remove the shoe return springs. Carefully pry the top of each spring from behind its tab on the torque spider. Unhook each spring from the torque spider and brake shoe and set it aside.
4. Remove the spring holding the top of each brake shoe together against the adjuster. Remove the adjuster screw and nut.



5. Gently remove each clip securing the brake shoes to the park actuating lever. Remove the brake shoes.
4. Use a brake spring tool and remove the shoe return springs (short and long). Unhook each spring from the brake shoes and set it aside.
5. Remove the spring clips and remove the brake shoes.

**CAUTION**

**Do not depress brake pedal while shoes and drum are removed from the vehicle. Pistons will be forced from the wheel cylinders causing fluid leakage and damage.**

6. Clean the brake assembly to remove brake debris, dust, dirt and mud.
7. See *Brake Drum Service* and rebore/replace drum as necessary.
8. See *Wheel Cylinder* and replace as necessary.

**CAUTION**

**Do not use solvents or other chemical cleaners unless formulated for cleaning brake parts.**

**Do not use compressed air to blow dust from brake assembly. Brake dust contains potentially harmful contaminants.**

**Brake Drum Service**

1. Rebore or replace drum:
  - if rubbing surface is rough or ragged, or if depth of scoring exceeds .010".
  - if inside diameter of drum at open end exceeds inside diameter at closed end by more than .010".
  - if surface variance exceeds .005" on the side.
  - if hard spots cause noticeable effects such as pedal pulsations or brake roughness. If spots are severe, replace drum.
  - if heat checking is plainly visible or can be felt with a fingernail. If checks are severe, replace drum.
  - if out-of-round condition exceeds .006" total indicator reading or if pedal pulsations or brake roughness is noticeable.
2. To measure a drum diameter, place gauge in drum so contact points are at greatest diameter. Be careful to hold both contact points at same depth (distance from outside edge of drum).
3. Rebore limit is .060" over original drum diameter.

4. Difference in diameter of drums on opposite ends of the same axle must not exceed .010", or when turning drums turn them in pairs to same oversize (within .010") to ensure equal braking effort on all wheels.

**CAUTION**

**Never rebore a drum to maximum wear or discard diameter.**

5. When re-boring a drum, remove only enough metal to obtain a smooth braking surface. If drum does not clean up when turned to maximum rebore diameter, replace it. Removal of more metal will affect ability of drum to dissipate heat and may cause drum distortion.

**Wheel Cylinder Service**

The wheel cylinder is a one piece cast assembly and is part of the torque spider. When servicing the wheel cylinder, it is not necessary to remove it from the vehicle. Removal of the torque spider and wheel cylinder is recommended only when replacement is required. To remove, see *Section 7 - Rear Axle and Rear Wheel Assemblies*.

Rebuild or replace wheel cylinder/torque spider whenever brake shoes are replaced, or more often when required to correct a leaking cylinder.

*Cleaning and Inspection:*

1. Whenever a wheel cylinder is disassembled, always inspect the cylinder bore for scoring, pitting and corrosion. A hard, crystal-like substance sometimes forms a ring in the cylinder bore near the place where the piston stops, when brakes are released.
2. Fine grade crocus cloth (or an approved cylinder hone) may be used to remove light roughness or deposits from the bore. Hone lightly and use brake fluid as a lubricant while honing. If the bore does not clean up readily, replace the cylinder.
3. After using crocus cloth or a hone, flush inside of cylinder with clean alcohol or brake fluid, and wipe dry with a lint-free cloth. Be sure all dust and grit are removed and bleeder valve and brake tube passages are clean.
4. The clearance between cylinder bore wall and pistons must be checked after the cylinder is cleaned up. If a narrow (1/8"- 1/4" wide) .006" feeler gauge can be inserted between the bore wall and a new piston, the clearance is excessive and the wheel cylinder must be replaced.

**NOTICE:** If the clearance between the pistons and the bore wall exceeds .005", a condition known as heel drag may exist. This causes rapid cup wear and may cause the pistons to retract very slowly when the brakes are released.

*Tips for assembly:*

1. Always use new wheel cylinder repair parts to rebuild wheel cylinder.
2. Dip the pistons and cups in clean brake fluid. Coat the cylinder bore with clean brake fluid.
3. Refer to Figure 5-1 or Figure 5-4 for reassembly
4. After reassembly is complete, hydraulic system must be bled of air. See *Bleeding the Hydraulic System*.

**Drum Brake Reassembly**

1. Place brake shoes into position on brake actuating lever tabs. Insert retaining pins.

Brake shoes may not be equal in length. The shoe with the shorter lining should be installed on the brake assembly side closest to the front of the vehicle. Shoe with longer lining installs to the rear.

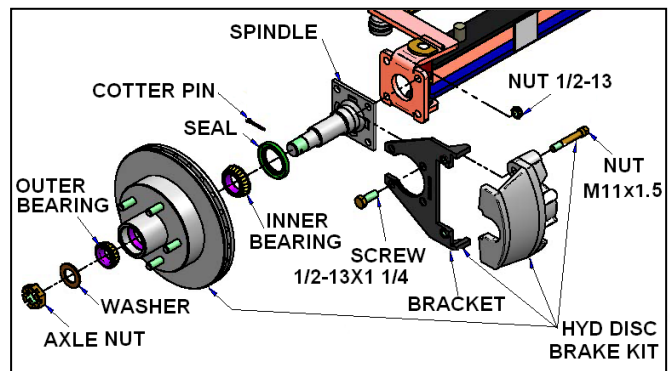
2. Screw adjuster assembly into minimum length position and insert between the tops of each brake shoe. Install blue spring under adjuster.
3. Insert the red spring into the left shoe (facing the brake assembly) onto its mounting post on the brake spider, and pry the top end of the red spring into position behind the torque spider retaining tab. Repeat with green spring mounted on the right side.
4. Check that brake shoes are correctly positioned into the slots provided in each master cylinder piston.
5. Install the brake drum 3/4 over the brake assembly and using a brake spoon or brake adjusting tool, rotate the brake adjuster until drag is felt against the brake drum. Push the drum fully onto the assembly.
6. Apply pressure to the brake pedal, pumping 2-3 times and releasing, then check to see if additional adjustment is required to create drag on the drum. Adjust as necessary to achieve slight drag on the drum.
7. When adequate drag is achieved (very slight drag), install drum fully onto brake assembly and install four new Tinnerman nuts.
8. Reinstall rear wheel/tire assembly and four lug nuts. Engage brake and tighten lug nuts in a crisscross pattern to a maximum 65-70 ft. lbs. Repeat for other rear wheel. Recheck lug nut torque with vehicle on the ground.

**FRONT DISC BRAKES**

Disc brakes are not adjustable and rarely cause problems. If problems are encountered, refer to the following service and inspections procedures for possible causes and solutions.

**Replacing Front Disc Brake Kit**

1. With vehicle on the ground, loosen wheel assembly mounting nuts.
2. Raise and secure vehicle as described in *Section 3-Lifting Instructions*.
3. Remove lug nuts, cotter pin, and axle nut.
4. Remove the brake line from the caliper.



**Figure 5-2**

5. Remove the M11x1.5 guide bolts attaching the caliper to the caliper bracket and remove caliper.
6. Remove hub/rotor, washer, seal and bearings.
7. Remove the 1/2x13x1 1/4 screws attaching the bracket and spindle to the front axle.
8. Reinstall wheel/tire assembly and lug nuts. Engage brake and tighten lug nuts in a crisscross pattern to a maximum 65 ft. lbs. Recheck lug nut torque with vehicle on the ground.
15. Perform all steps in *Bleeding the Hydraulic System*.
16. Recheck lug nut torque with vehicle on the ground.

**Brake Caliper Service**

1. Remove the M11x1.5 guide bolts attaching the caliper to the caliper bracket.
2. Use a prying tool between the old pads and the rotor and slowly compress the piston back into the caliper. Be careful that the brake fluid reservoir (at the master cylinder) does not overflow when compressing the brake fluid back into the system.

Columbia / ParCar OEM Parts  
evtechnicalservices.com



3. The caliper can be removed from the rotor and supported (not by the brake line) and the old pads removed from the caliper.
4. At this time the bushings in the caliper should be inspected for cracking or wear. Remove the metal guide bolt sleeves (inside the bushings) by pressing the metal sleeve only. The bushing can then be removed from the caliper once the sleeve is removed. Replace the bushings if cracked or worn.
5. After inspection of the bushing, it can be reinstalled into the caliper. Lubricate the inside of the bushing with a NON PETROLEUM (important) lubricant such as "Syl Glyde" and the outside of the sleeve (not on the guide bolt). Push the bolt sleeve into the bushing from the outside of the caliper 3/4 of the length of the sleeve.
6. The guide bolts can be reused with a new application of thread locking material. Place the caliper over the rotor and into the caliper bracket.
7. Insert the guide bolts into the bolt sleeves and push until the guide bolts contact the bracket holes and tighten to 45 ft/lbs.
8. Perform all steps in *Bleeding the Hydraulic System*.
9. Reinstall front wheel/tire assembly. Torque axle nut to 45 ft. lbs. then tighten until new cotter pin can be inserted. Install lug nuts, engage brake and tighten lug nuts in a crisscross pattern to a maximum 65 ft. lbs.
10. Recheck lug nut torque with vehicle on the ground.
1. With vehicle on the ground, depress the brake pedal to engage the brakes. Loosen wheel assembly mounting nuts.
2. Raise and secure vehicle as described in *Section 3-Lifting Instructions*.
3. Remove wheel/tire assembly. Remove axle nut and washer.
4. Remove brake caliper guide bolts (Figure 5-2) from the brake caliper mounting bracket.
5. Remove caliper assembly by sliding off rotor. Do not disconnect hydraulic line from caliper.
6. The rotor may now be removed from the spindle by removing the dust cover, cotter pin, axle nut, bearing and washer.
7. At this point the rotor may be either resurfaced or replaced with a new rotor.
8. Complete reassembly by reversing Steps 1-6.
9. Reinstall brake caliper with guide bolts. Use thread locking material on guide bolts and torque to 45 ft. lbs.
10. Reinstall front wheel/tire assembly. Torque axle nut to 45 ft. lbs. then tighten until new cotter pin can be inserted. Install lug nuts, engage brake and tighten lug nuts in a crisscross pattern to a maximum 65 ft. lbs.
11. Recheck lug nut torque with vehicle on the ground.

**Hub/Rotor Service**

MVP vehicles use a one piece hub and rotor.

Runout in a disc brake rotor is like out-of-roundness in a drum brake. It causes a loss of brake pedal height because of extra lining clearances. Runout wears the calipers rapidly due to the high speed pulsations created whenever the brakes are applied.

Runout tolerances are critical, usually only about .002".

**NOTICE:** .As much as .015" of metal can be removed from each side of the rotor without exceeding specifications. If removing the maximum specified amount will not clean up a rotor's problems, install new rotors.

**CAUTION**

**Do not depress brake pedal while brake calipers are removed from the vehicle. Pistons will be forced from the wheel cylinders causing fluid leakage and damage.**

**HYDRAULIC BRAKE ADJUSTMENTS**

**Brake Linkage Adjustment (Will require removal of the inspection doors panel)**

Gently depress brake pedal and check for free movement before master cylinder piston is depressed. If there is no free travel in the pedal before the master cylinder plunger begins to move, or if the free travel of the pedal exceeds 3/8", adjustment of the brake rod will be required.

1. Remove hair pin clip and clevis pin from master cylinder push rod at the brake pedal.
2. Rotate push rod clevis accordingly to decrease or increase free play as required.
3. Reconnect push rod clevis with clevis pin and hair pin clip.
4. Recheck brake pedal for correct free movement.

**Brake Fluid Maintenance**

The master cylinder is located behind the front cowl inspection door. (Figure 2-1)



1. Maintain fluid level within 1/4" of master cylinder filler opening.
2. Changing brake fluid:

As a result of use, brake fluid loses some of its original qualities and may become contaminated. When performing major brake work to the hydraulic system, remove old fluid and replace it with clean brake fluid.

Brake fluid must be changed following extended usage or contamination. Anytime fluid looks milky or dark, there are contaminants in the fluid.

If any of the hydraulic system parts are corroded, or the fluid is discolored, flush the hydraulic system to remove old fluid, then fill with clean brake fluid.

3. Contamination. Soft or swollen rubber parts, or milky or discolored fluid indicate the brake fluid is contaminated.

Drain old fluid from the system.

Replace cups and seals.

Flush hydraulic system with clean brake fluid.

Refill system with clean brake fluid.

4. Handling and storing brake fluid:

Keep brake fluid clean. Do not allow any foreign material in the fluid.

Prevent any petroleum product (gasoline, kerosene, oil, grease, etc.) from contaminating the brake fluid.

Use only clean containers for dispensing brake fluid. Do not use containers contaminated with dirt, grease, etc.

Always cover or cap brake fluid containers when not actually dispensing the fluid. If containers are left open or uncovered, the fluid absorbs moisture from the air.

Never reuse old brake fluid drained from the system. Used brake fluid is contaminated to some extent. Store brake fluid containers in a clean, dry place.

**Bleeding The Brake System**

**▲WARNING**

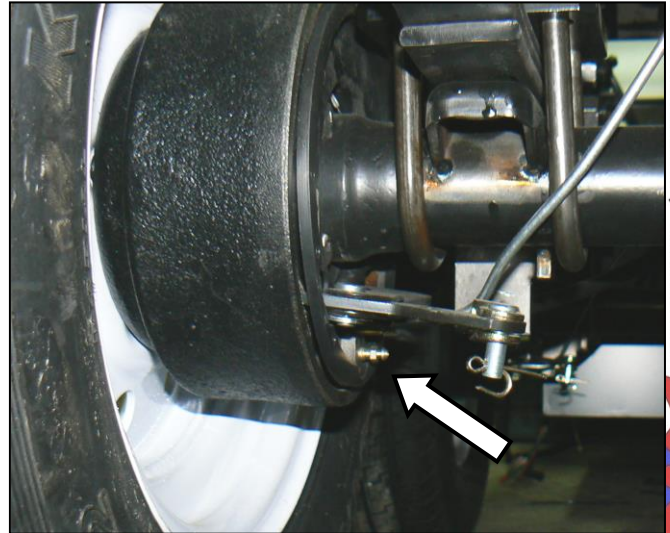
**Brake fluid can cause irritation of eyes and skin, and may be harmful if swallowed. If fluid is swallowed, induce vomiting by administering two tablespoons of salt in a glass of warm water. Call a doctor. In case of contact with skin or eyes, flush with plenty of water. Get medical attention for eyes. KEEP BRAKE FLUID OUT OF THE REACH OF CHILDREN!**

If any line or cylinder has been opened when servicing the brake system, or when satisfactory brake adjustment is unobtainable, or pedal is spongy, bleed air from the hydraulic system as follows:

1. Install a length of appropriate size plastic tubing over the brake assembly bleeder valve (Figure 5-3).

**NOTICE: On vehicles equipped with only rear hydraulic brakes, bleed the right side wheel first. On vehicles equipped with both front and rear hydraulic brakes, bleed both right side wheels first, then both left side wheels.**

2. Place the other end of tubing in any clear glass jar containing about 1/2" of brake fluid.
3. Open bleeder valve (Figure 5-3) by rotating it counterclockwise about 1/2 turn. With master cylinder full of fluid at all times, slowly depress the brake pedal repeatedly until fluid flows from bleeder valve free of air bubbles.



**Figure 5-3 – Rear Wheels**

4. Add fluid to master cylinder to bring 1/4" from cover. Close bleeder valve. Repeat procedure on left wheel.
5. Do not reuse fluid unless it is clear and free of sediment. If it is impossible to bleed all air from system, master cylinder is faulty and a master cylinder repair kit should be installed.
6. Vehicles with front hydraulic disc brakes have calipers with two bleed valves. Do bleeding from the highest bleed valve.

Columbia / ParCar OEM Parts  
evtechnicalservices.com  
TECHNICAL SERVICES

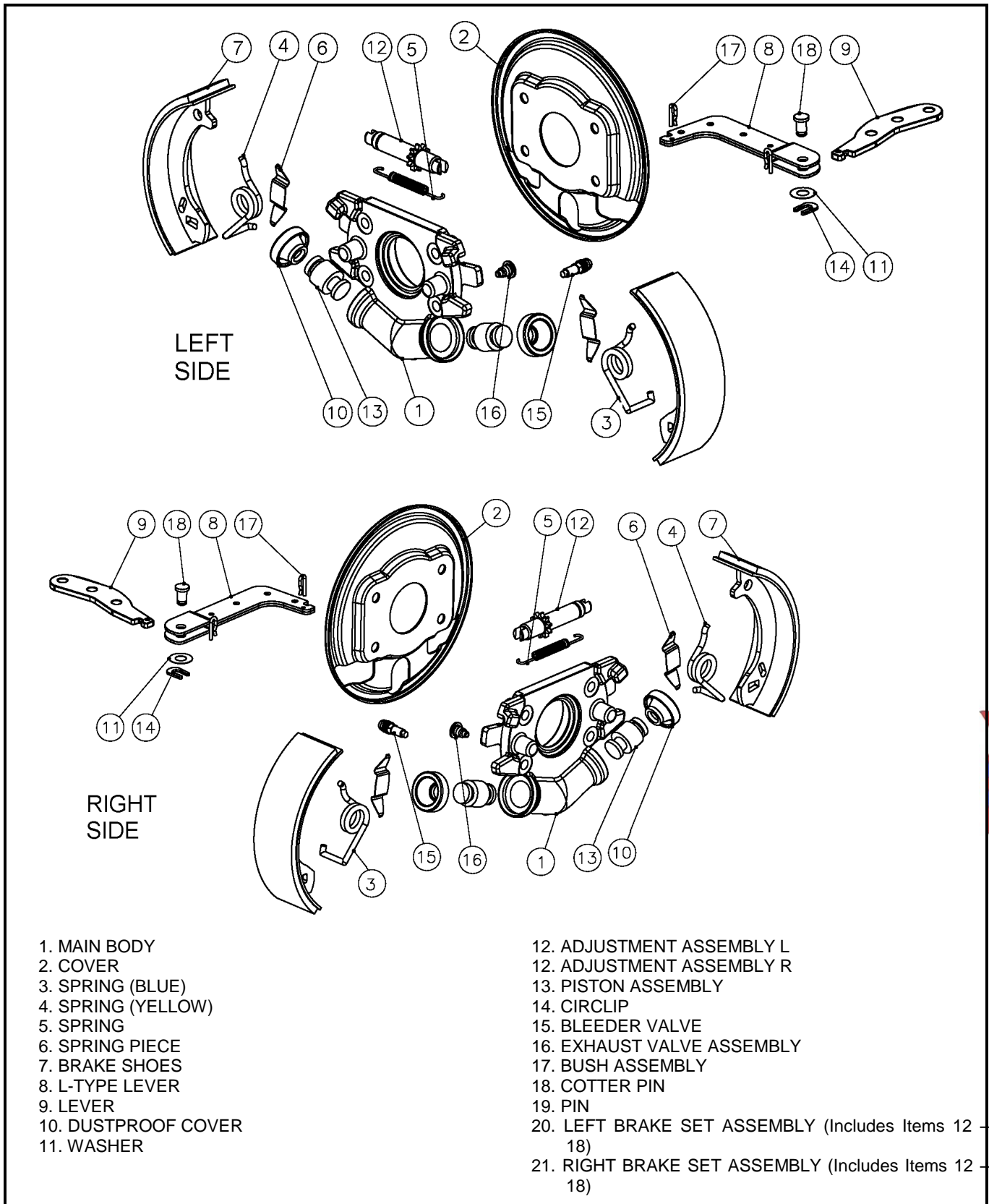


Figure 5-4 NKL Hydraulic Brakes



**Columbia ParCar Corp.**

**Service Manual**

**Section 6 – Front Wheels, Suspension & Steering**

The steering system is operated by rotating the steering wheel. The steering wheel is connected to a hydraulic front mount steering system which moves the left and right spindles.

**NOTICE:** Always inspect the condition of vehicle steering components before making adjustments. Worn, broken or damaged parts must be replaced before proper adjustment can be performed.

**WHEELS**

**Removing Wheels**

1. Before raising vehicle, with wheels on the ground, break loose the lug nuts.

**WARNING**  
To perform this service, raise vehicle using floor jack and safely support it with jack stands positioned under main frame. See Section 3 - Lifting Instructions.

2. Remove lug nuts and wheel assembly from the hub.

**Installing Wheels**

1. Place wheel assembly on the hub studs.
2. Tighten lug nuts by hand and wrench until snug using a crisscross pattern).
3. Lower the vehicle as instructed in Section 3 Maintenance -Lifting Instructions.
4. Torque the lug nuts to 65 ft. lbs. (89 Nm) using the same crisscrossing pattern.

**TIRES – PNEUMATIC**

**NOTICE:** This section does not apply to foam filled tires.

In the event of a flat tire, remove wheel assembly from the vehicle and follow standard tire repair procedures.

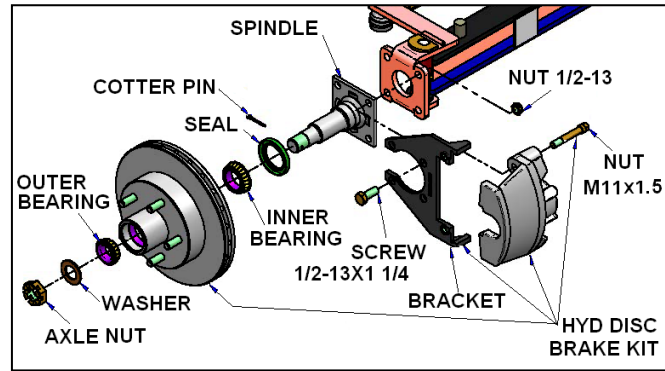
**WARNING**  
Use care when inflating a tire with a high pressure air supply. due to low pressure requirements of a small tire, over inflation may be reached in a matter of seconds. Over inflation could cause the tire to explode resulting in possible personal injury. Do not exceed maximum tire pressure of 51 psi.

**FRONT WHEEL HUB ASSEMBLY**

**Removal**

**WARNING**  
To perform this service, raise vehicle using floor jack and safely support it with jack stands positioned under main frame. See Section 3 Maintenance- Lifting Instructions.

1. With vehicle on the ground, loosen wheel assembly mounting nuts.
2. Raise and secure vehicle as described in Section 3-Lifting Instructions.
3. Remove lug nuts, cotter pin, and axle nut.



**Figure 6-1**

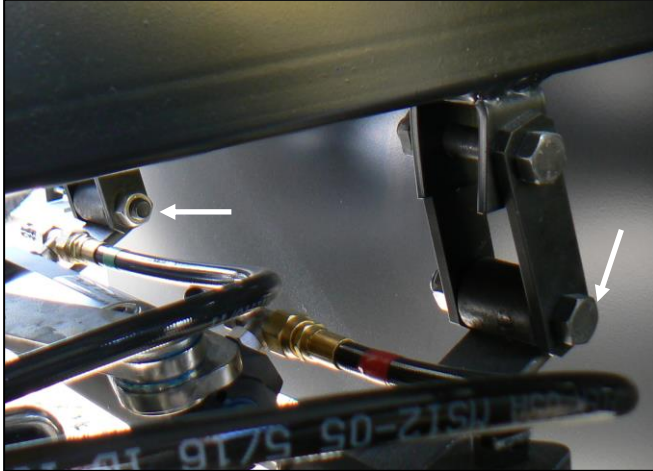
4. Remove the M11x1.5 guide bolts attaching the caliper to the caliper bracket and remove caliper.
5. Remove hub/rotor, washer, seal and bearings.
6. Inspect components for abnormal wear, damage etc. Replace as necessary.
7. Pack bearings with lithium wheel bearing grease before installing.

**Installing**

1. Clean spindle and apply a thin coating of grease.
2. As shown in Figure 6-1 reassemble the components and place on spindle.
3. Tighten axle nut until resistance is felt when turning the rotor/brake assembly, then back off slightly, then back off until a new cotter pin can be inserted.
4. Attach the wheel assembly to the rotor/brake assembly using lug bolts.
5. Tighten lug bolts by hand and wrench until snug using a crisscross pattern.

Columbia / ParCar OEM Parts  
evtechnicalservices.com  
TECHNICAL SERVICES

6. Lower the vehicle to the ground and torque the lug bolts to 65 ft. lbs. (23 Nm) using the same crisscrossing pattern.

**FRONT AXLE REMOVAL****Figure 6-2**

1. See Figure 6-2.
2. Disconnect the hydraulic steering and brake lines.
3. At each end of the leaf springs remove the four 9/16-18 x 3 bolts attached to the shackle straps.

**STEERING**

1. Remove the steering wheel by removing the center cap. This will allow access to the steering nut, washer and woodruff key.
2. Remove the steering hydraulic pump and hoses.
3. Reassembly by reversing the above steps.  
Torque the steering nut to 300 in. lbs.

**STEERING ADJUSTMENTS****Alignment**

1. Raise vehicle and remove front wheel assemblies.
2. Measure the distance between the front hub assemblies or the front rotor/brake assemblies.
3. Measurements are to be made in the middle front and rear edges of the assemblies. Difference between the two measurements should not exceed 1/16".
4. If adjustment is required, loosen the jam nuts on the front tie rod assemblies and rotate to achieve the correct measurement.





**COLUMBIA** 

**Columbia ParCar Corp.**

**Service Manual**

**Section 7 – Rear Axle**



Columbia / ParCar OEM Parts  
[evtechnicalservices.com](http://evtechnicalservices.com)

**REAR AXLE WHEEL BEARINGS**

Rear axle wheel bearings are sealed type bearings and cannot be repacked. Bearings must be replaced if worn or damaged. Refer to *Disassembling Rear Axle* for bearing replacement procedures.

**REMOVING REAR AXLE**

1. Before raising vehicle, with wheels on the ground, break loose the lug nuts.
2. Raise the vehicle and safely support it with jack stands positioned under main frame.. See *Section 3 - Lifting Instructions*.
3. Remove lug nuts and remove rear wheel/tire assemblies.
4. Place a floor jack under the axle.

**⚠ WARNING**

**Rear axle is heavy and awkward to move. Get help lifting and removing axle to prevent possible personal injury.**

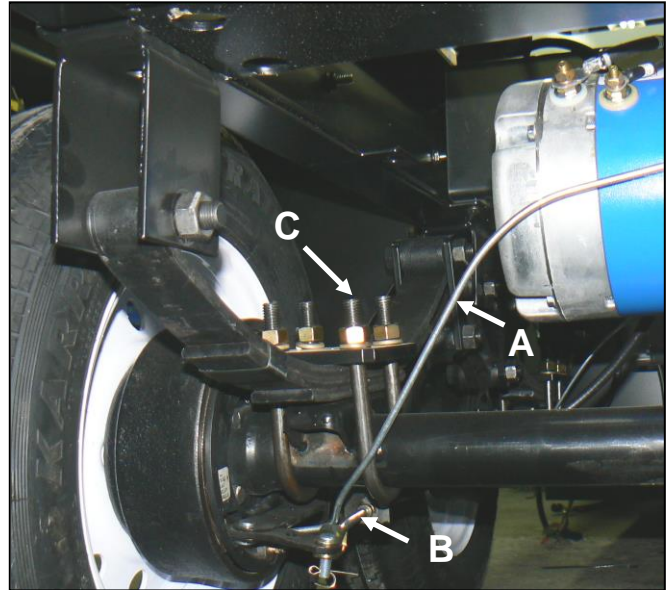
5. See Figure 7-1. Disconnect hydraulic brake line (A) and parking brake (B) from brake assembly. Remove the U-bolts (C) securing the axle to the leaf springs.

This will now allow the axle to be lowered.

**DISASSEMBLING REAR AXLE**

The rear axle is a precision assembly and any repair or replacement of parts must be done with great care in a clean environment. Before attempting to perform any axle service, read and understand all the procedures in this section.

- Handle all gears with extreme care.
- The axle assembly should be degreased prior to disassembly.
- Dirt is an abrasive and will cause premature wear of bearings and other parts. A small wash tank for cleaning parts should be close by when disassembling the axle assembly.
- Use soft, clean, lint-free towels to dry components before cleaning.
- Parts should be cleaned with emulsion cleaners or petroleum based cleaners.



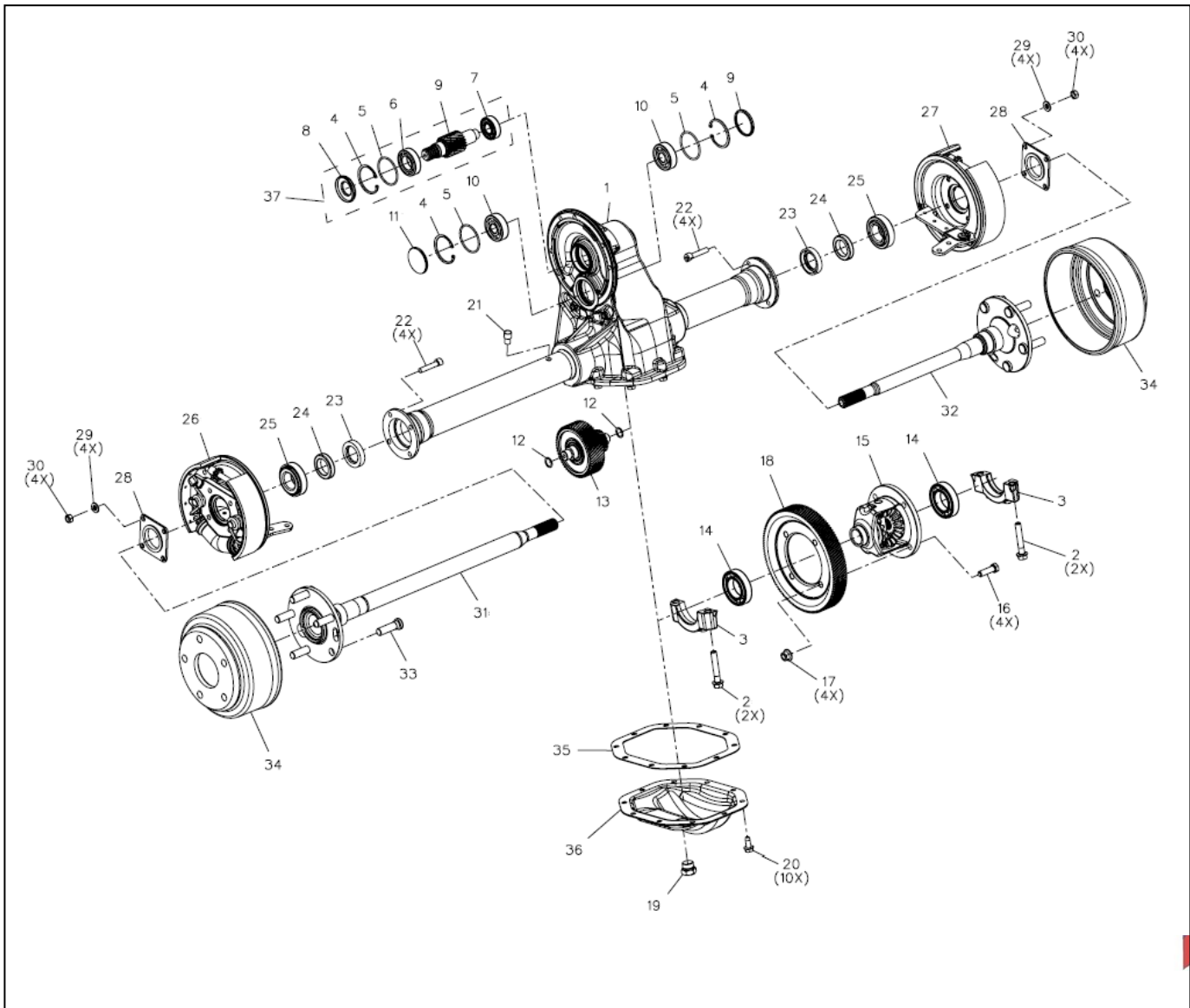
**Figure 7-1**

**⚠ DANGER**

**Do not use gasoline as a cleaner.**

**NOTICE: Bearings should not be dried by spinning with compressed air. This can damage mating surfaces due to lack of lubrication.**

- After drying, parts should be lightly coated with SAE 30 weight oil to prevent corrosion damage. If parts are to be stored for a prolonged period of time, they should be wrapped in newspaper and plastic.
- Bearings, seals and O-rings should be replaced with new parts whenever they are removed. Always wipe seals and O-rings with SAE 30 oil before installing.
- Snap rings must be removed/installed with care to prevent damage to bearings, seals and bearing bores.
- Remove all residual gasket material from sealing surfaces.
- Use soft, clean, lint-free towels to dry components before cleaning.
- Parts should be cleaned with emulsion cleaners or petroleum based cleaners. Inspect all parts for signs of wear or damage and replace if necessary.



Columbia / ParCar OEM Parts  
**evtechnicalservices.com**

ITEM	QTY	DESCRIPTION	ITEM	QTY	DESCRIPTION	ITEM	QTY	DESCRIPTION
1	1	Housing, Axle	13	1	Shaft, Interm. Gear	25	2	Assy, Bearing, Roller
2	4	Bolt, Diff. Cap	14	2	Bearing, Ball	26	1	Assy, Brake, LH (Hyd)
3	2	Bearing Cap	15	1	Differential Case Assy	27	1	Assy, Brake, RH (Hyd)
4	3	Ring, Snap	16	4	Screw, Cap	28	2	Seal
5	3	O-Ring	17	4	Nut, Lock	29	8	Washer, Flat
6	1	Bearing, Ball	18	1	Gear, Final Drive	30	8	Nut, Lock
7	1	Bearing, Bal	19	1	Plug, Drain/Fill	31	1	Shaft, Axle, LH Long
8	1	Oil Seal	20	10	Screw, Tapping	32	1	Shaft, Axle, RH Short
9	1	Shaft, Input	21	1	Vent	33	10	Bolt, Wheel
11	2	Plug End Cap	22	8	Screw	34	2	Drum, Brake
10	2	Bearing, Ball	23	2	Seal, Oil	35	1	Gasket
12	2	O-Ring	24	2	Ring, Retaining	36	1	Plate, Cover
						37	1	Pinion & Seal Kit

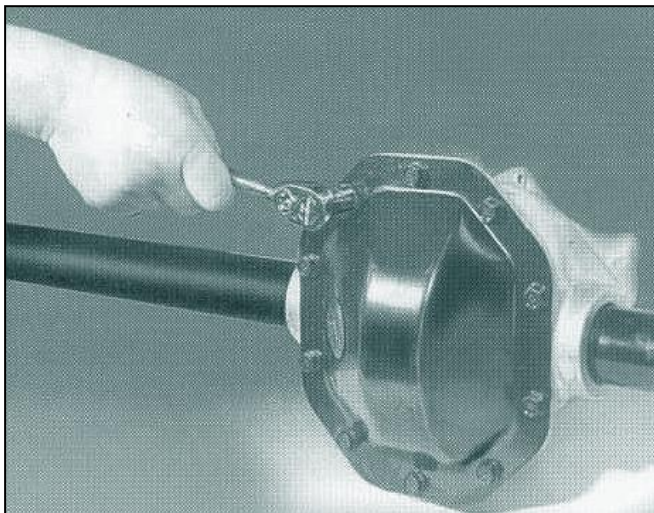
**Figure 7-2 Spicer Rear Axle**

**▲ DANGER**

**Safety glasses should be worn at all times when disassembling and assembling the axle.**

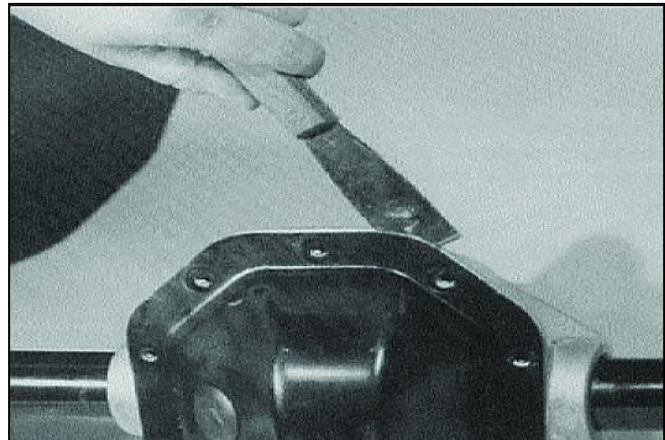
All callout numbers in steps refer to Figure 7-2.

1. Remove drum (34).
2. Remove the 4 screws (22) holding the seal (28).
3. Remove brake assembly (26), bearing (25), ring (24), oil seal (23) and axle shaft (31).
4. Repeat above to remove and disassemble the other shaft.
5. See Figure 7-3. Remove ten cover plate (36) screws (20).

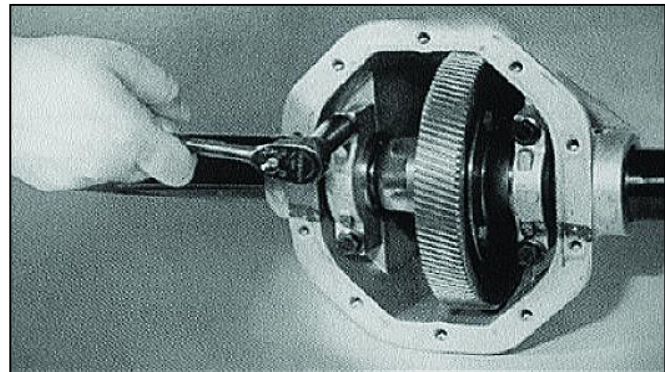


**Figure 7-3**

6. See Figure 7-4. Position the axle housing (1) over a drain pan. Using a putty knife, separate the cover plate from the housing. Use care to not damage the housing sealing surfaces or to deform the cover plate.
7. Remove four bearing cap bolts (2) and both bearing caps (3). See Figure 7-5.
8. Remove the differential case assembly from housing.

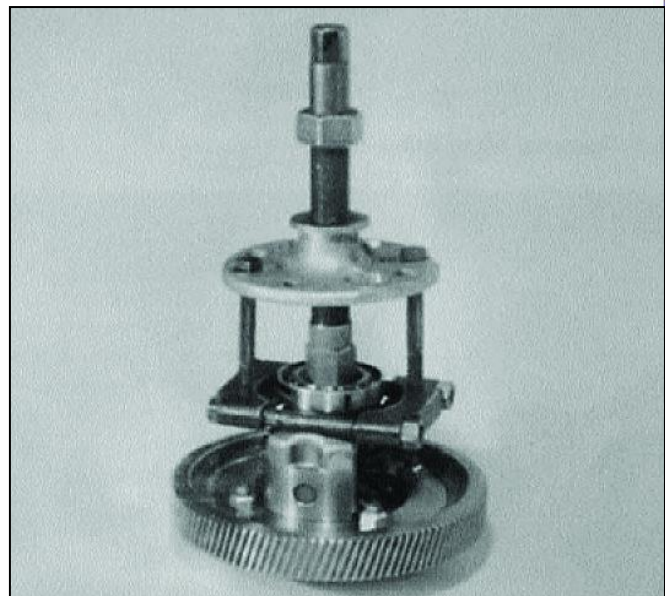


**Figure 7-4**



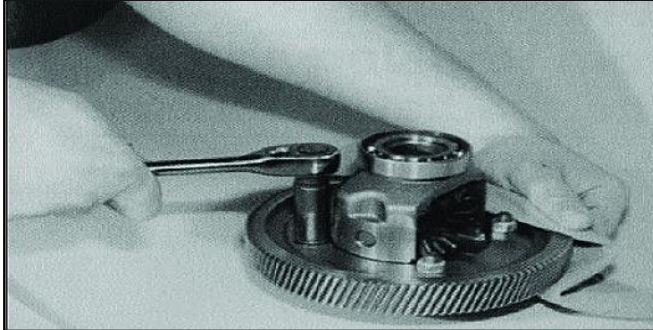
**Figure 7-5**

**NOTICE:** Bearing caps are marked for identification. Letters or numbers are stamped in horizontal and vertical position. When reassembling, install caps back in their original positions, using these stamps as a guide.



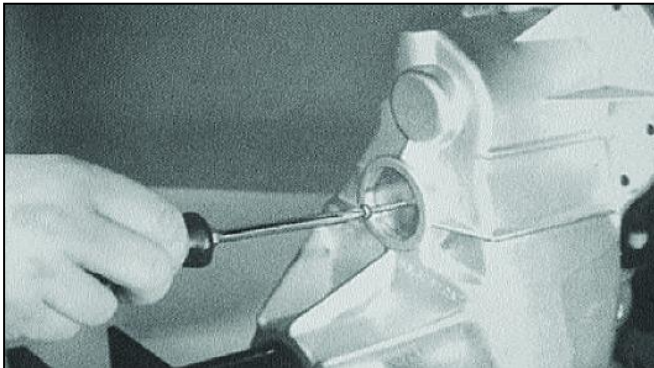
**Figure 7-6**

9. Using a bearing puller, remove differential bearings (14) from each side of the differential case. See Figure 7-6.
10. See Figure 7-7. Remove four bolts (16) and nuts (17) from the final drive output gear (18). Remove gear from differential case. Use care not to damage gear teeth.



**Figure 7-7**

11. See Figure 7-8. Punch or drill a 1/8" diameter hole near the center of each intermediate cup plug (11). Insert a suitably sized sheet metal screw until the metal bore plug is forced out of the bearing bore.



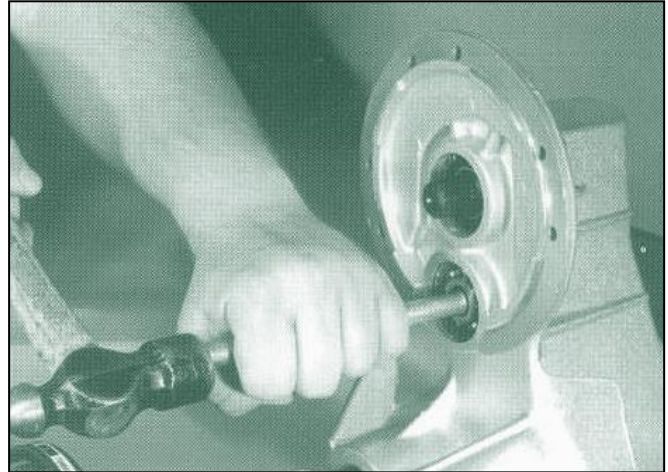
**Figure 7-8**

12. See Figure 7-9. Remove snap rings (16) from each intermediate bore.



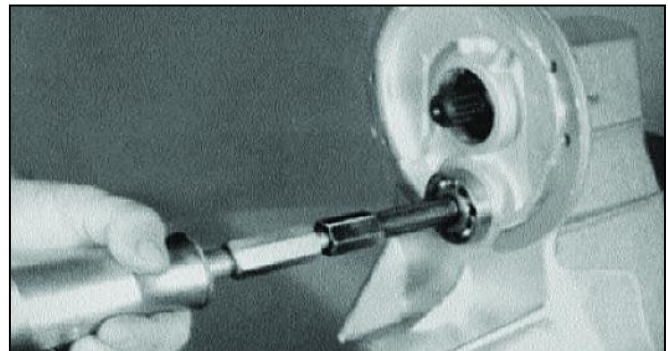
**Figure 7-9**

13. See Figure 7-10. Using a brass drift pin, drive the intermediate shaft (9) from the flange side of housing. Shaft should travel far enough to allow engagement of I.D. bearing puller.



**Figure 7-10**

14. See Figure 7-11. Using an I.D. bearing puller attached to a slide hammer, remove intermediate bearing (10) from flange side of housing.



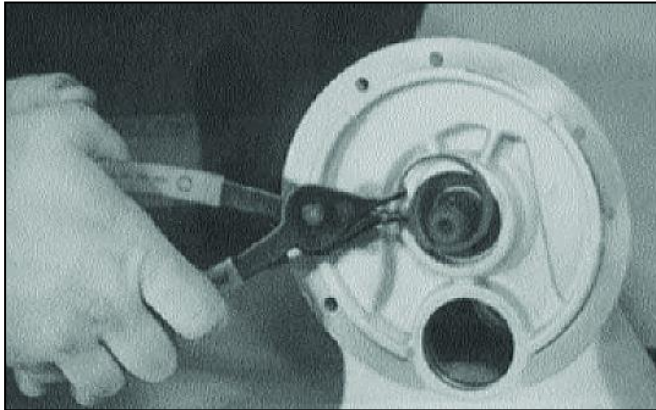
**Figure 7-11**

15. Repeat steps 12-15 for intermediate bearing on opposite side.

**NOTICE: Shaft and gear assembly must be supported by hand as not to damage gear teeth.**

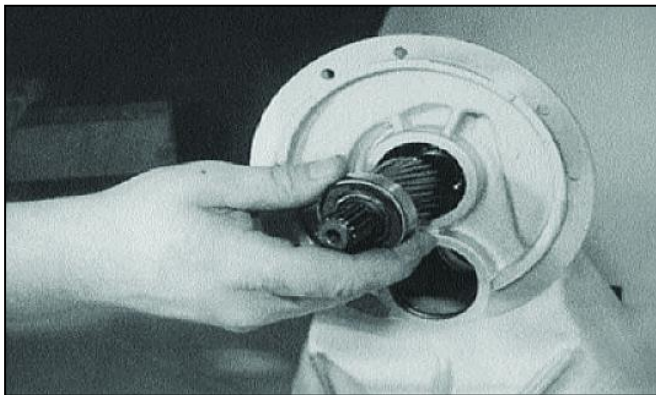
**NOTICE: Small end of intermediate shaft and gear assembly must be tilted toward opening in bottom of housing for removal.**

16. See Figure 7-12. Remove snap ring (4) from input shaft bore (9).



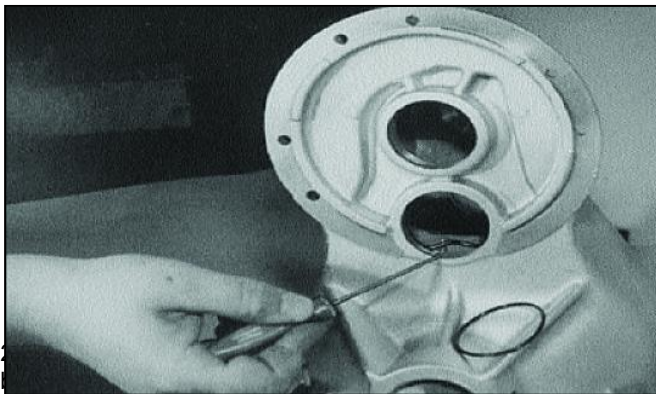
**Figure 7-12**

17. See Figure 7-13. Pull input shaft assembly (9) from housing. The input shaft assembly should slide out easily. If resistance is encountered, a slide hammer may be required.



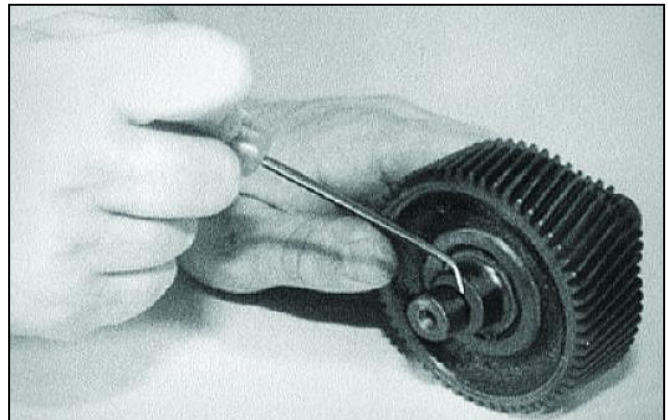
**Figure 7-13**

18. See Figure 7-14. Remove O-rings from outer input bearing bore and both intermediate bores.



**Figure 7-14**

19. See Figure 7-15. Remove O-rings (12) at each end of intermediate shaft (13) on bearing shoulders.



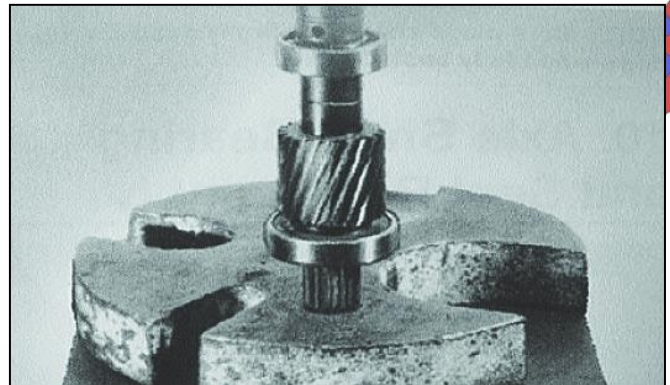
**Figure 7-15**

20. Clean the axle housing and carrier cover (36) with lint-free rags. Remove all traces of old silicone sealant from sealing surface of cover and housing.

**ASSEMBLING REAR AXLE**

All callout numbers in steps refer to Figure 7-2.

1. Prior to installing, wipe new O-rings with SAE 30 weight oil. Install one O-ring (5) into outer input bearing bore.. Install two O-rings (5) into intermediate shaft bearing bores and two O-rings (12) onto intermediate shaft and gear assembly (13).
2. Press inner and outer bearings (6, 7) on input shaft (9) until seated against bearing shoulders. See Figure 7-16.

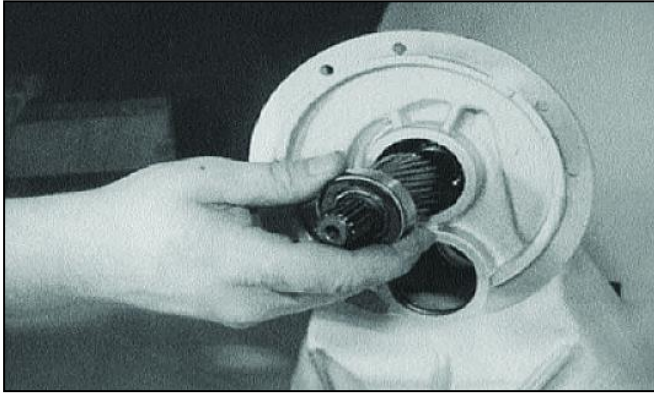


**Figure 7-16**

**NOTICE:** Input shaft assembly must be supported by hand as not to damage gear teeth. Use care if using a hammer to coax shaft and gear into correct position.

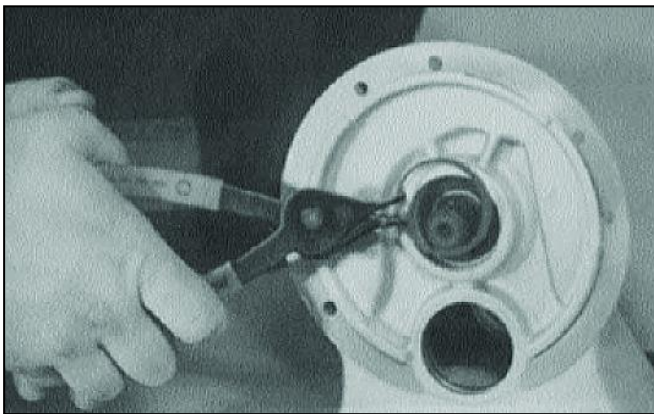
Columbia / ParCar OEM Parts  
evtechnicalservices.com

- See Figure 7-17. Install input shaft (9). Bearings (6, 7) and shaft should slide easily into housing. If resistance is encountered, use a plastic or leather mallet to tap shaft into position.



**Figure 7-17**

- See Figure 7-18. Install outer snap ring (4) at input shaft bore.



**Figure 7-18**

- After O-rings (12) are installed on shaft (9) and housing (1), install intermediate shaft and gear assembly (9) through bottom opening in housing.

**NOTICE: Small end of intermediate shaft and gear assembly must be tilted toward bottom opening until bearing trunnion visually engages intermediate bores**

- Align both bearing trunnions with intermediate bore. Continue supporting intermediate shaft and gear assembly with one hand and insert the flanged side bearing (10) into opening. To seat the bearing past the O. After flanged side bearing is seated past snap ring groove, install snap ring (4). Repeat procedure for opposite side bearing and snap ring. Use caution as not to damage gear.
- See Figure 7-19. Position differential case assembly (15) with flanged side trunnion face down on work surface. Align final drive gear (18) mounting holes with differential case. Install four bolts (16) and nuts (17). Bolts should be

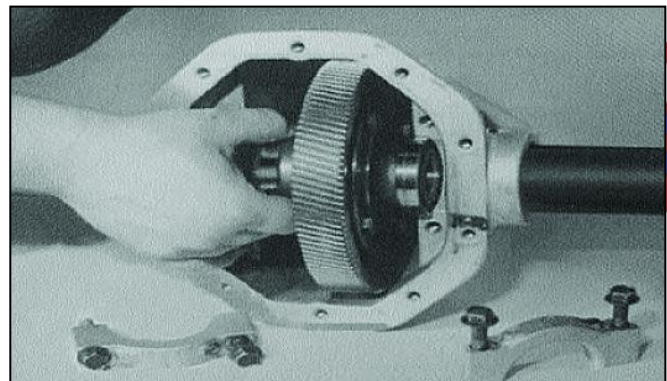
installed from differential flange side. Torque nuts to 35-45 ft. lbs.



**Figure 7-19**

- Differential bearings (14) can be installed on differential case (15) before or after installing ring gear. Use care not to damage differential bearings or final gear (18) when installing the opposite component.
- See Figure 7-20. Position housing (1) with opening facing up. Insert differential case, final drive gear (18) and bearing (14) assembly into housing. Make sure teeth of gear (18) mesh with teeth of small gear on intermediate shaft (13) and that both turn freely.

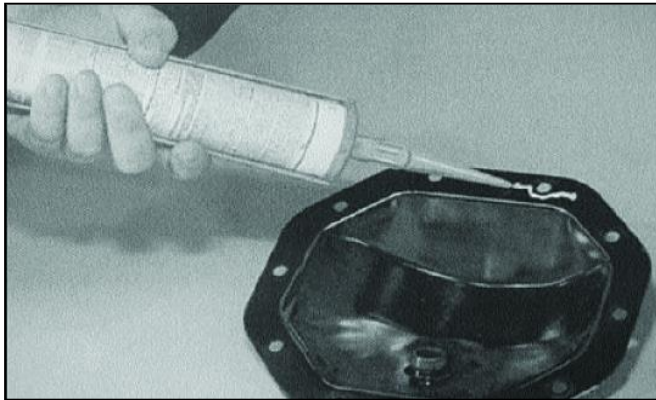
**NOTICE: Bearing caps are marked for identification. Letters or numbers are stamped in horizontal and vertical position. When reassembling, install caps back in their original positions, using these stamps as a guide.**



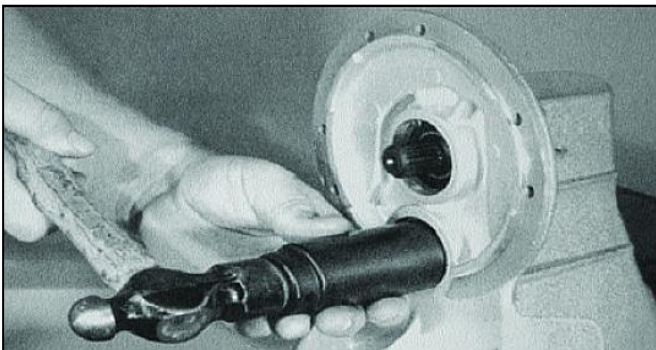
**Figure 7-20**

- Install differential bearing caps (2) with bolts (3). Torque bolts to 35-45 ft. lbs.
- See Figure 7-21. Place a small bead of RTV (non-acidic) silicone sealant to flange of cover plate (36). Sealant should be applied to inside of cover plate mounting holes
- Install cover plate (36) with ten bolts (20). Torque bolts to 16-24 ft. lbs.





- See Figure 7-22. Install new intermediate cup plug (11) to both sides of housing (1). Use Loctite Safety Solvent #75559 to clean bores, then apply Loctite RC 609 to housing bores. Cup plugs can be installed by using a properly sized driver and hammer. Cup plugs should be firmly seated against snap rings (4).



**Figure 7-22**

- Replace the brake assembly (26), bearing (25), ring (24), oil seal (23) on the axle shaft (31) and insert into the housing tube. Shaft may have to be rotated to engage differential splines during installation.
- Using the 4 screws (22) attach the seal (28) to the housing tube.
- Repeat above to assemble the other shaft.
- Remove fill plug (19) in cover plate (36). Fill axle assembly with 12 ounces (360 ml) of Light Weight Gear Lubricant, SAE 30. Install fill plug. If it is a threaded plug, torque to 25-40 ft. lbs.

**INSTALLING REAR AXLE**

**⚠WARNING**

Rear axle is heavy and awkward to move. Get help lifting and removing axle to prevent possible personal injury.

**NOTICE:** Make sure rear axle has oil in the differential before installing.

- Carefully position axle into place.
- Secure axle to springs with four U-bolts, washers and nuts. Torque nuts to 65 ft. lbs.
- Connect hydraulic and parking brake lines.

**NOTICE:** After installation is complete, bleed the hydraulic brake system. See Section 5-Accelerator & Brake System.

- Install brake drum and wheel assemblies. Drive the vehicle and test axle operation.

**CHANGING DIFFERENTIAL OIL**

Differential oil must be changed at least once a year under normal vehicle usage. If vehicle is operated under extreme conditions, or for more than 8 hours a day, oil should be changed twice a year. It is not necessary to remove the axle to change the differential oil.

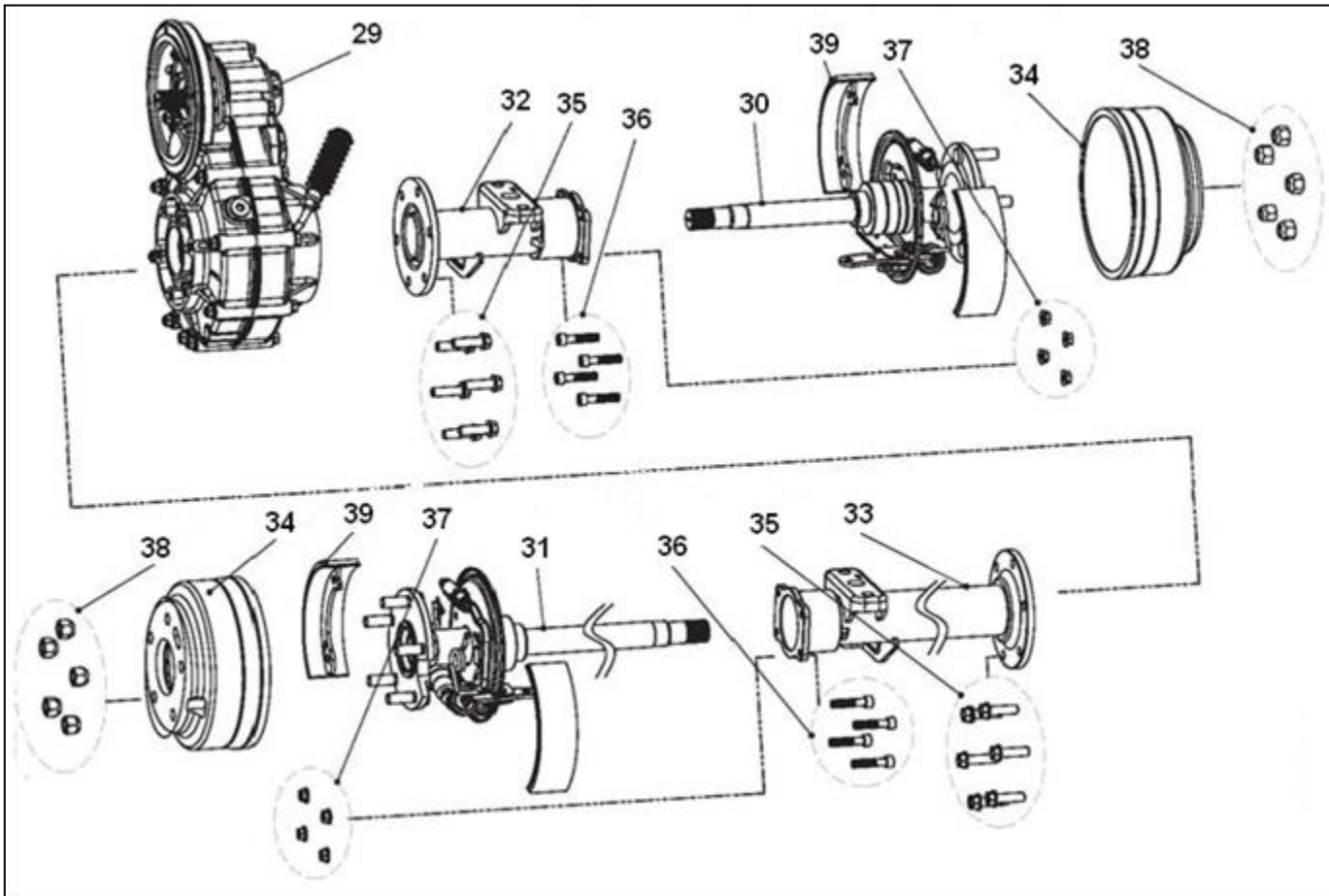
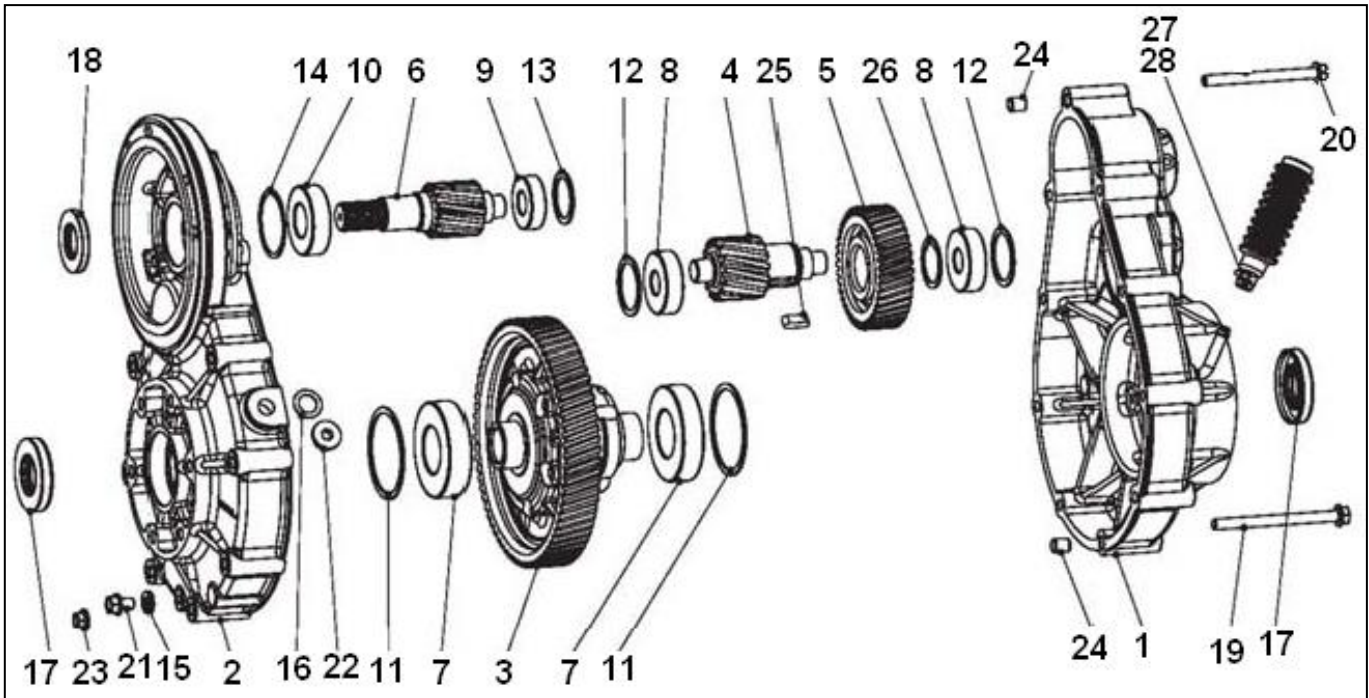
**⚠WARNING**

To perform this service, raise vehicle using floor jack and safely support it with jack stands positioned under main frame tubes. See Section 3 – Maintenance Lifting Instructions.

- Remove ten cover plate bolts (Figure 7-4). Remove cover and drain oil into drain pan.
- Clean carrier cover with lint-free rag.
- Place a small bead of RTV (non-acidic) silicone sealant to flange of cover plate (36). Sealant should be applied to inside of cover plate mounting holes (Figure 7-21).
- Install cover plate (36) with ten bolts (20). Torque bolts to 16-24 ft. lbs.
- Remove fill plug (19) in cover plate (36). Fill axle assembly with 12 ounces (360 ml) of Light Weight Gear Lubricant, SAE 30.
- Install drain/fill plug. Torque to 25-40 ft. lbs.



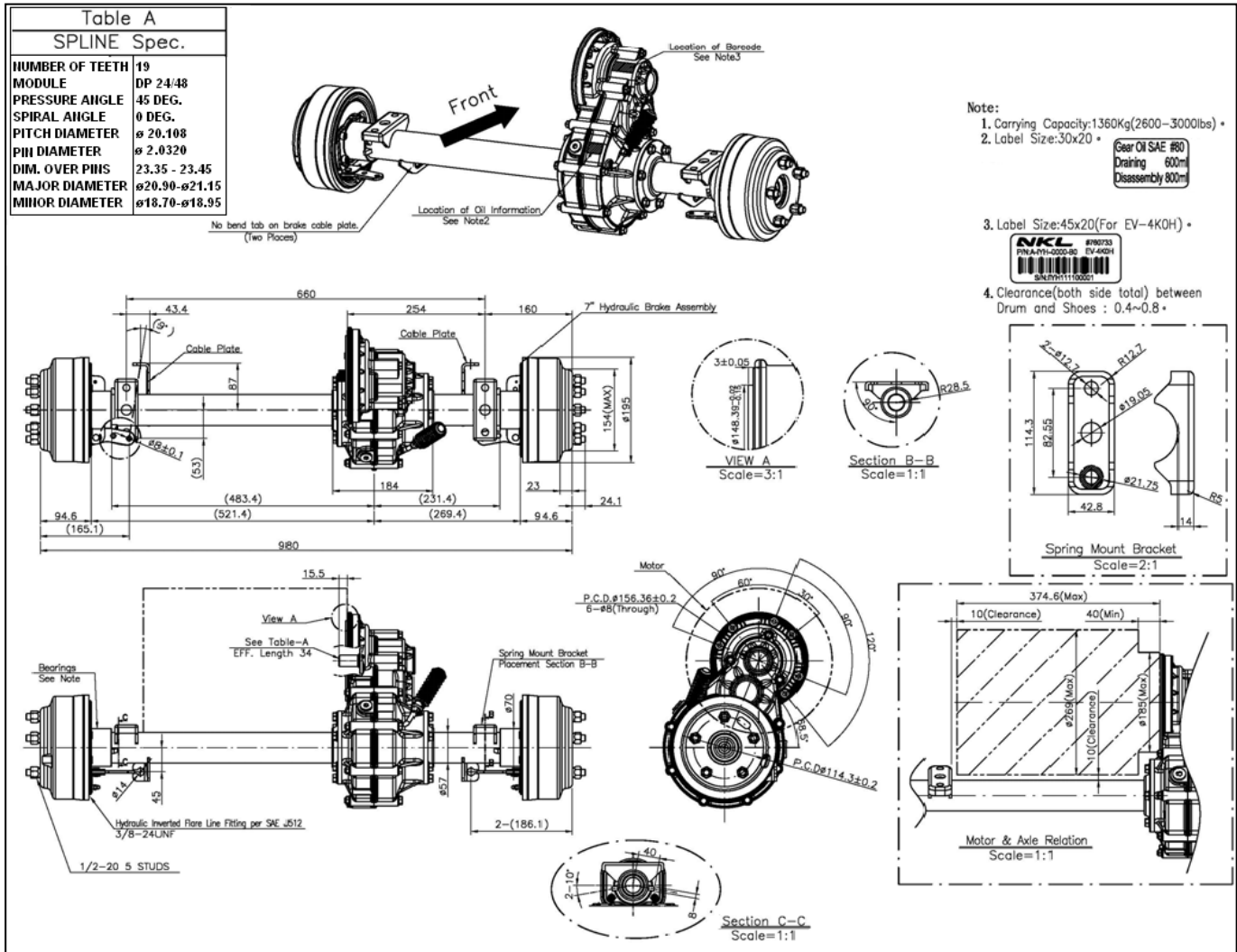
MVP NKL AXLE 16.77



Columbia / ParCar OEM Parts  
evtechnicalservices.com



### MVP NKL AXLE 16.77 Cont.



Columbia / ParCar OEM Parts  
evtechnicalservices.com

ITEM	DESCRIPTION	QTY	ITEM	DESCRIPTION	QTY	ITEM	DESCRIPTION	QTY
1	Cover Case Assy	1	14	Shim	1	27	Breather Tube	1
2	Gear case	1	15	Washer	1	28	Ring	1
3	Carrier Gear Assy	1	16	Washer	1	29	Gear Box Assy	1
4	Gear 15T	1	17	Seal	2	30	Shaft Assy R	1
5	Gear 40T	1	18	Seal	1	31	Shaft Assy L	1
6	Gear 18T	1	19	Bolt	7	32	Tube Assy R	1
7	Ball Bearing	2	20	Bolt	3	33	Tube Assy R	1
8	Ball Bearing	2	21	Bolt	1	34	Drum	2
9	Ball Bearing	1	22	Bolt	1	35	Bolt	12
10	Ball Bearing	1	23	Nut	10	36	Bolt	8
11	Shim	2	24	Location Pin	2	37	Nut Shrapnel	8
12	Shim	2	25	Machine Key	1	38	Nut	10
13	Shim	1	26	Circlip	1	39	Brake Shoe	4

**NOTICE** Additional information on this axle is being developed.  
NKL is replacing Dana.



**Columbia ParCar Corp.**

**Service Manual**

**Section 8 – Battery and Battery Charger**



Columbia / ParCar OEM Parts  
[evtechnicalservices.com](http://evtechnicalservices.com)

**IMPORTANT INFORMATION**

The type of battery used in a Columbia vehicle has a service requirement which is quite different from that of an automotive battery.

The electric vehicle battery supplies all of the power to drive the vehicle. During operation the power stored in the batteries is expended. While the amperage drain rate can vary greatly depending on the type of service, the duration of use and the number of “starts” and “stops” made during a day, the batteries nevertheless progress through each duty cycle from “fully charged” to an almost depleted state. This type of service is known as “deep cycle” service and electric vehicle batteries are specifically designed to handle this type of service.

Proper performance of your Columbia Vehicle can only be obtained from specified deep cycle, electric vehicle batteries.

**SAFETY INFORMATION**

**▲ DANGER**

**All batteries used in electric vehicles can explode! Always wear full face shield when working on or near batteries. Hydrogen fumes are a natural byproduct of charging and discharging and are extremely explosive.**

**Do not smoke around electric vehicle batteries. Keep sparks and flames away from batteries. Battery charging should only be done in a well-ventilated area. Refer to Section 9-Batteries for details.**

**Batteries contain acid which can cause severe burns. Avoid contact with skin, eyes, or clothing. Wear full face shield and rubber gloves when working on or near batteries.**

**Do not attempt to charge a battery if it is frozen or if the case is bulged excessively. Frozen batteries can explode. Dispose of battery.**

**▲ WARNING**

**When working around batteries, use approved insulated tools, remove jewelry such as rings, watches, chains, etc. and place an insulating material such as wood, plastic, rubber, etc. over batteries covering all connections.**

**If any problems are found during scheduled maintenance or inspections, do not operate vehicle until repairs are completed. Failure to make necessary repairs could result in fire, property damage, severe personal injury or death.**

**NOTICE: Automotive batteries should never be used for “deep cycle” application, as their useful life will be very short.**

**Install surge arrestors on incoming AC power lines. Surge arrestors will help protect electrical/electronic components in the charger and vehicle from all but direct or “close proximity” lightning strikes.**

**Antidotes**

- **External: Flush with water. Call a physician immediately.**
- **Internal: Drink large quantities of milk or water. Follow with milk of magnesia or vegetable oil.**
- **Eyes: Flush with water for fifteen minutes. Call a physician immediately.**

**BATTERY INSPECTION & MAINTENANCE**

Batteries and connections must be clean and dry. See *BATTERY CLEANING*.

Be sure battery hold downs are properly tightened. A loose hold down may allow the battery to become damaged from vibration or jarring. A hold down that is too tight may buckle or crack the battery case.

Weekly inspect battery posts, clamps and cables for breakage, loose connections and corrosion. Replace any that are damaged.

Check to see that battery cap vent holes are clear. Plugged vent holes will not permit gas to escape from the cell and could result in battery damage.

**BATTERY CLEANING**

Battery terminal connections should be individually cleaned and maintained annually. More frequent cleaning may be required under heavy use, or as batteries age.

**NOTICE: Make note of any accessory wire connections before disconnecting batteries. Refer to wiring diagrams for proper connection.**

1. Remove battery cables and wire connections from all battery terminals.
2. Brush battery cable and wire connections clean using soft brass wire brush.
3. Replace battery cable terminals that are damaged or corroded.
4. Keep the batteries clean, fully charged, properly secured and terminal connections tight. Do not over tighten connections. Acid soaked dirt on the battery tops causes current leakage, reduced battery efficiency and promotes rapid self-discharge during storage.
5. Hose wash battery tops periodically with clean, low-pressure water to keep them free of acid spillage, dirt and other debris. If vented batteries are used, make sure vent caps are secure before washing. Do not hose wash electronic controllers, switches, solenoids, and other electrical control devices. Direct water away from these components, covering them if necessary.



6. Wash battery tops with a baking soda mixture (1/2 cup per quart of water) and a stiff non-metallic bristle brush if a low-pressure hose does not remove the dirt. Rinse with clean water. Take care to ensure that the baking soda mixture does not enter the vent opening in the battery caps.
7. Make sure that the battery tops are clean and dry before putting the batteries into storage.

**BATTERY SERVICE (WATER)**

The operating environment of the electric vehicle could vary widely. Severe service operations will require that periodic maintenance recommendations be adjusted to shorter time intervals.

Use only distilled water in your batteries. Vehicle batteries may use up to 16 quarts of water during their useful life and non-distilled water may contain harmful minerals which will have a cumulative adverse effect on battery performance and life.

Watering intervals are dependent on the local climate, charging methods, application, and age of batteries. After the initial watering of new batteries, it is recommended that batteries be checked once a month until you get a feel for your water consumption rate.

Typically for a heavy use application, recommend watering is maximum of once per week, and for light use applications once per month

**Adding Water** (See Figure 8-1)

- Check the electrolyte level on brand new batteries before putting them into service, and at least weekly on batteries in service. Water use increases as batteries age.
- Never allow the electrolyte level to fall below the top of the plates (A). If the plates are exposed, add only enough distilled water to cover the plates before charging.
- Do not overfill batteries. Do not fill the water level up into the well of the filler tube of the cell. Electrolyte expands and can overflow during charging (B). Water added to replace the spillage dilutes the electrolyte and reduces its specific gravity. Cells with lower specific gravity have lower charging capacity.
- Make sure the electrolyte covers the plates before charging (C). Fill cells to the markers only after batteries are charged.

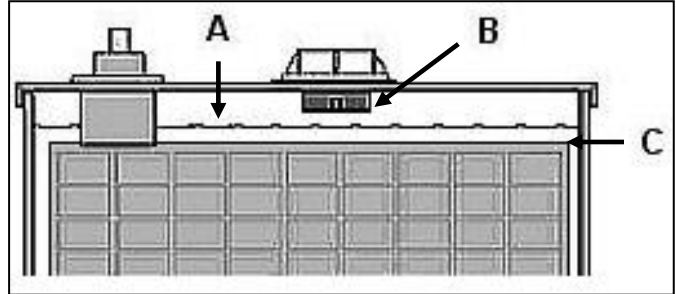


Figure 8-1

**SINGLE POINT WATERING SYSTEM**

**NOTICE: The following information does not apply to sealed batteries.**

MVP vehicles have a Single Point Watering System (Figure 8-2) used for adding water to the battery pack. It consists of a fill tube, one end having a filter screen, the other having a female coupler and a rubber squeeze bulb.

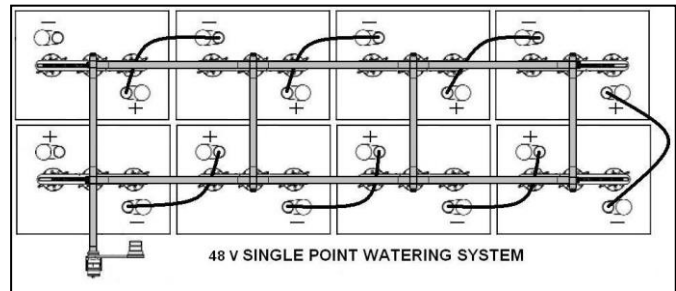


Figure 8-2

**NOTICE: To avoid overfilling of the Single Point Watering System do not operate this system on brand new batteries. New batteries should be in service 1 to 2 weeks with heavy use or 3 to 4 weeks with light use. System is to be used only after fully charging the batteries and batteries are warm.**

When using this system, check the battery pack water level weekly by:

- Inserting the fill tube filter end in a distilled water supply.
- Attaching the female coupler to the battery pack male coupler.
- Squeeze the rubber ball until firm which indicates that filling is complete. Immediately disconnect the couplers by depressing the push button on the female coupler. If the water supply is left connected after the filling process is finished it could lead to an overflow.

US Batteries features SpeedCap™ battery cell caps. See Figure 8-3. To open SpeedCap™ locate the two tabs on either side of the center cell of the battery. Move these tabs in the directions shown in Figure 8-3.



**Figure 8-3**

**NOTICE:** Do not use SpeedCaps™ as handles to lift or move battery.

**BATTERY CHARGING**

**⚠ DANGER**

Observe all safety information in this section, safety information listed at the beginning of this section, and safety information in *Section 1* of this manual.

Columbia electric vehicles are equipped with a solid state, onboard, fully automatic, Delta-Q Battery Charger as standard equipment. See Figure 8-3.

It is important to be aware of the differences and improvements over prior chargers, which are explained in the Delta-Q Charger Operating Instructions that accompany every vehicle.

Correct charging methods extend battery life and vehicle range between charges. Before the first new vehicle use, completely charge new batteries. Charging time is affected by age of battery, condition of battery, state of discharge, temperature of electrolyte, AC line voltage level, and other variables. Charging time usually takes 12 hours. New batteries need up to four hours more charging time than “mature” batteries.

Always schedule enough charging time so that the charger completes a full charge cycle. Opportunity charging is an acceptable practice for use during a shift to extend the range, but always allow for a full charge cycle at end of shift.

Limit the use of new batteries between charges for the first 15 – 20 cycles. New batteries have less capacity than batteries which have been cycled.

Recharge batteries immediately after use. Leaving batteries in a state of discharge will reduce their capacity and useful life. Battery chargers are voltage specific; 24, 36 or 48 volts. However, chargers can be programmed at the factory for different types of batteries, as well as different brands and capacities of batteries. Refer to Battery Brand Algorithms for Charger Programming, See Table 1.

The lead-acid storage battery supplies electrical power through the chemical action. This action is reversible, which means the battery must be connected to a charger and have an electrical current passed through it in the direction opposite to the direction of discharge in order to restore the battery’s active chemicals.

The Delta-Q Charger will not over charge batteries if left plugged in.

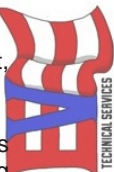
**Charger Safety Information**

**⚠ WARNING**

Do not attempt to charge a battery if it is frozen or if the case is bulged excessively. Frozen batteries can explode. Dispose of battery.

- Charge batteries in well ventilated area.
- Ventilation fans should be located at the highest point in charging area. These fans should be able to exchange the air 5x per hour. Consult a local HVAC engineer.
- Remove rings and watches prior to service. Only trained technicians should repair or service the charger. Contact Columbia for assistance.
- Replace worn, cut or damaged power cords or wires.
- Do not connect the power cord near fuels, grain dust, solvents, thinners, or other flammables.
- Install surge arrestors on incoming AC power lines. This protects from all but direct or close proximity lightning strikes.
- Do not cover charger cabinet cooling fins. This protects the charger from overheating.
- Make sure all battery and charger connections are clean and tight. This prevents overheating and arcing at the terminal. Replace as necessary.
- Disconnect negative (-) cable first to avoid crossing terminals that would create a spark.

**NOTICE:** When using ordinary automotive chargers, there is the possibility of overcharging and damaging the cells.



**BATTERY BRAND ALGORITHMS**

ALGORITHM ID	ALGORITHM DESCRIPTION	AMP HOUR	TYPE	DESIGNED FOR	COMPATIBLE WITH
1	Trojan Flooded	225	Flooded	Trojan T105	150 - 260Ah 6V, 8V, 12V flooded golf
3	Trojan Constant Power dv/dt	225	Flooded	Trojan T105	150 - 260Ah 6V, 8V, 12V flooded golf
5	Trojan Group 31 Flooded	130	Flooded	Trojan 30XHS, 31XHS	85 - 150Ah 12V flooded "marine" Exide Orbital AGMs, Optima AGMs
6	Deka 8G31 Gel	100	Gel	Deka 8G31	Deka 98 - 120Ah gel
7	Trojan 305 Constant Power dv/dt	305	Flooded	Trojan L16	Trojan J305
8	Concorde 100Ah AGM	100	AGM	Concorde 104Ah AGM	Concorde 80-150Ah AGM
11	200 - 255Ah Flooded Constant Power dv/dt	230	Flooded	US Battery US125 & 225	200 - 255Ah flooded golf
12	Exide Gel	240	Gel	Exide DF06240	200 - 300Ah gel
21	Exide Flooded	210	Flooded	Exide 3ET200, FF06255, 185PZB210	Exide200 Ah – 300 Ah Flooded
26	Deka 8GGC2 Gel	180	Gel	Deka 8GGC2	Deka 150 - 230Ah gel
35	Concorde 200Ah AGM	200	AGM	Concorde 233Ah AGM	Concorde 200 - 255Ah AGM
38	Trojan 12V Golf 113%	150	Flooded	Trojan T1275	120 - 170Ah 8V, 12V flooded golf
42	Discover 80 - 150Ah AGM	100	AGM	Discover EV31A	other 80 - 150Ah AGM
43	Discover 200 - 400Ah AGM	300	AGM	Discover EVL16A, EVGC6A, EV185A	Discovery 200 Ah – 400 Ah AGM
51	Exide 180Ah Gel	180	Gel	Sonnenschein 180Ah Gel	150 - 200Ah gel
52	Exide 105Ah Gel	105	Gel	Sonnenschein 105Ah Gel	80 - 130Ah gel
62	Trojan Group 31 Flooded dv/dt	130	Flooded	Trojan 30XHS, 31XHS	85 - 150Ah 12V flooded "marine"
71	140 - 200Ah Flooded Constant Power dv/dt	170	Flooded	US Battery 8V-GC	140 - 200Ah Flooded
72	250 - 335Ah Flooded Constant Power dv/dt	305	Flooded	US Battery US-305HC	250 - 320Ah Flooded
73	400Ah Flooded Constant Power dv/dt	415	Flooded	US Battery L-16HC	330 - 425Ah Flooded
93	Trojan 12V Golf	150	Flooded	Trojan T1275	120 - 170Ah 8V, 12V flooded golf
125	Fullriver 160-220Ah AGM	180	AGM	Fullriver DC180-6, DC224-6	Fullriver 160 - 220Ah AGM
126	Fullriver 85-145Ah AGM	110	AGM	Fullriver DC115-12	Fullriver 85 - 145Ah AGM
141	Fullriver 300-370Ah AGM	335	AGM	Fullriver DC335-6	Fullriver 300 - 370Ah AGM
151	Fullriver 220-290Ah AGM	250	AGM	Fullriver DC250-6	Fullriver 220 - 290Ah AGM

Columbia / ParCar OEM Parts  
 eotechnicalservices.com  


**Table 1**

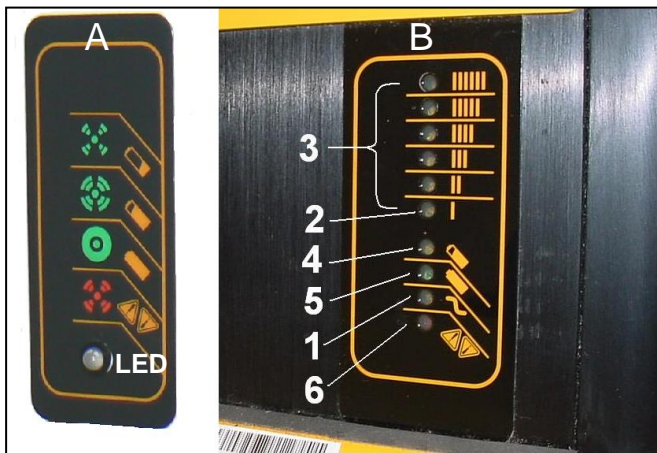
**DELTA-Q CHARGER OPERATION**

MVP's are equipped with a remote panel (Fig. 8-4 A) with a single LED which indicates the Delta Q status. For each Delta Q the remote panel will be located on the cab side next to the drivers position. See SINGLE LED DISPLAY.

1. Connect power cord at charger receptacle to properly grounded wall outlet.

**NOTICE: Connect the charger AC cord to a source capable of supplying 15 amperes minimum per charge (20 amperes recommended). The charger is equipped with an equipment-grounding AC electric cord, and a grounding type plug.**

2. Connect the cord to an appropriately installed receptacle grounded in accordance with the National Electric Code ANSI/NFPA 70, and all local codes and ordinances.



**Figure 8-4**

3. The Yellow AC power LED (No. 1, Fig. 8-4B) should remain illuminated while the Charger is plugged into an AC source. If Yellow LED is not lit, before replacing Charger, recheck the AC connection and the AC source fuse or breaker. If this fails to correct the problem, contact your Columbia Dealer for assistance.
4. Charger will automatically turn on and conduct a short self-test and battery pack test. All LED's will flash in sequence and then a trickle current will be applied to batteries until a minimum voltage is reached. In Figure 8-4B No. 3 indicates the Bar Graph and No. 2 indicates the lowest LED. Three (3) amperes is displayed as the lowest LED on the Bar Graph
5. If the batteries meet the minimum voltage requirements of the Charger, signifying they are serviceable (chargeable), the Charger enters the bulk charging (higher amperage-constant current) stage. The Bar Graph LED's indicate the electrical current being delivered to the batteries as the Charger moves through its automatic charge profile. The length of charge time at each level will vary due to battery size and battery charge depletion.

**NOTICE: If the batteries are excessively discharged, the Delta-Q will not be able to charge the complete set of batteries. The Delta-Q will have the RED FAULT LED (No. 6, Fig. 8-4B) flashing red (see RED LIGHT CHARGER ERROR CODES). It will then be necessary to follow the instructions in EXCESSIVELY DISCHARGED BATTERIES.**

6. When the Yellow LED (No. 4, Fig 8-4B) is lit, the Charger has completed the bulk stage and the batteries are at approximately 80% state of charge. The 80% LED remains on as the last 20% of charge is returned to the batteries in the second phase (constant voltage phase).

**NOTICE: You can terminate charging at this point if necessary. The vehicle can be used, but completing the charge cycle is highly recommended.**

7. Charge completion is when the 100% Green LED is lit, (No. 5, Fig. 8-4B). Repeated "Short Charging" leaving the charge short of 100% will shorten operating cycle distance and reduced battery life.
8. A low current "finish-charge" phase returns and maintains batteries to maximum capacity. The 100% Green LED will blink until "finish charge" phase is complete.
9. A 100% Green LED continuously lit indicates the batteries are completely charged. The Charger may now be unplugged from the AC source. If the batteries will not be used for a length of time, check monthly for the charge level. It is also acceptable to leave the Charger plugged in. The Delta-Q has the capability to test and recharge if necessary.
10. A fault occurring while charging causes the RED FAULT LED to flash with a code relaying the error. Some errors may require repair by a qualified technician and others may be simply transient and will automatically recover when the fault condition is eliminated and the Delta-Q cycled by disconnecting the AC source for a minimum of 11 seconds.

**NOTICE: A Yellow (Amber) blinking LED in the upper Bar Graph (No. 3, Fig. 8-4B) usually indicates the thermostatic control has limited the Charger output due to ambient temperature conditions. It is still charging, but at a reduced rate.**

Columbia / ParCar OEM Parts  
evtechnicalservices.com  
TECHNICAL SERVICES



**SINGLE LED DISPLAY (Figure 8-4A)**

SOLID GREEN – Charging complete, in maintenance mode

FLASHING GREEN – Short < 80% charge  
Long > 80% charge

GREEN when battery not connected – Algorithm number

FLASHING YELLOW – Reduced power mode: low AC voltage or high internal charger temperature.

FLASHING RED – Charger error. Reset charger power and see RED LIGHT CHARGER ERROR CODES.

**NOTICE: Do not disassemble the charger. There are no serviceable parts.**

**RED LIGHT CHARGER ERROR CODES**

**1 Flash**

Battery Voltage High: Auto-recover. May be temporary condition, or wrong charger installed, i.e. 36 volt charger on 48 volt battery pack.

**2 Flash**

Battery Voltage Low: Auto-recover. Confirm each individual batteries minimum voltage with a volt meter. Two or more 6 volt batteries register less than 5.85 volts, or accumulative total pack voltage has been discharged to less than 20% remaining. Vehicle operation will cease until batteries are recharged. See Special Procedure for Excessively Discharged Batteries in this section.

**3 Flash**

Charge Timeout: The charging did not complete in allowed time, 12-14 hours. This may indicate a battery problem, or that the charger output was reduced due to high ambient temperatures. Disconnect AC supply, confirm sufficient ventilation, allow cool down time, and restart charger.

**4 Flash**

Check Battery: The batteries could not be trickle charged up to a minimum level to start charger. This may be the result of badly discharged batteries, or one (or more) damaged cells. See Special Procedure in this section.

**5 Flash**

Over-Temperature: The charger shut down due to high internal temperature. May require reset (AC unplugged) and a cool down to restart charging cycle. This fault may indicate inadequate cooling airflow or high ambient air temperatures. Check for debris or blockage at cooling fins. Move the vehicle to a cooler better ventilated area, or adjust time of day when charging.

**6 Flash**

Delta-Q Charger Fault: An internal fault was detected and charger may need to be checked/replaced by a qualified dealer technician. It may also be the result of badly discharged batteries, or one (or more) damaged cells. A RED 6 FAULT flash must be validated first by testing individual batteries with a voltmeter, and see Special Procedures, before deciding charger has failed.

**A Steady Red Fault LED**

Confirms an internal electrical fault of the Delta-Q and also requires charger replacement and return.

**CHARGING PROCEDURE**

1. Check electrolyte level in all cells. Add distilled water as necessary to cover tops of plates. Do not over fill, as electrolyte expands during charging.
2. Be sure charger is turned OFF. Insert electrical plug into vehicle's charger receptacle.
3. Charger will start automatically. Check that amp meter rises fully when charger starts. If charger needle only rises to half scale or does not rise at all, check AC outlet for proper power supply or check charger owner's manual for testing and repair information.

**TESTING BATTERIES**

**Specific Gravity Test**

**NOTICE: Specific Gravity Test information does not apply to sealed batteries.**

It is possible to determine a battery's ability to perform by measuring the specific gravity of each cell with a hydrometer. The hydrometer readings indicate two things:

- State of Charge - The amount of electrical power stored in the battery.
- Condition - The ability of battery to store and deliver power.

**NOTICE :Batteries should be fully charged before performing specific gravity tests to determine battery condition. Hydrometer tests of batteries not fully charged are misleading and inconclusive.**

**Hydrometer Test**

1. Squeeze rubber bulb and insert nozzle in cell, release bulb, slowly drawing electrolyte up into barrel.
2. Adjust electrolyte level in barrel so float rides free of bottom but is not striking top of barrel.
3. Hold hydrometer vertically, making sure float moves freely and is not contacting sides of barrel. Read scale at the level of electrolyte in the barrel. Record the reading.



4. Return electrolyte to cell from which it was removed.
5. Repeat these steps on all battery cells.

Hydrometer readings are affected by the temperature of the electrolyte being tested. Measure the temperature of the electrolyte, and correct the readings as follows:

**Above 80°F:** Add .004 to the specific gravity readings for each 10° above 80°F (26°C).

**Below 80°F:** Subtract .004 from the specific gravity readings for each 10° below 80°F (26°C).

**Results Interpretation**

State of charge. Check specific gravity of each cell. See Table 2 & 3.

Specific Gravity vs, State of Charge	
SG Reading at 80° F.	State of Charge
1.250 – 1.270	100%
1.220 – 1.240	75%
1.190 – 1.210	50%
1.160 – 1.180	25%

Table 2

Specific Gravity vs. Action Required				
Battery	SG Reading			Action
	Cell 1	Cell 2	Cell 3	
1	1.100	1.100	1.100	Charge & recheck
2	1.260	1.180	1.250	Cell 2 bad – replace battery
3	1.250	1.260	1.250	Good
4	1.190	1.170	1.120	Charge & recheck Suspect cell 3

Table 3

If the difference between the highest and lowest cell is 0.050 (50 points) or more, the battery is nearing the end of its useful life and should be replaced.

**DISCHARGE (LOAD) TEST**

The discharge, or load test, is the recommended method of determining battery condition because it simulates electric vehicle operation under controlled conditions. A 75 amp draw is applied to the battery bank with a Load Tester. The time it takes the battery bank to drop to 31.5 volts, along with individual battery voltages, is used to determine battery condition.

**NOTICE: Use of automotive type of load tester is not recommended and will offer inaccurate results.**

**Use an appropriate volt tester that gives voltage and minutes of discharge.**

**Test Preparation**

The following preparations must be verified before discharged load testing. Should any of the following recommendations not be performed, results of testing will be inaccurate and misleading.

- Batteries must receive a full charge before conducting Discharge (Load) Test.
- Discharge (Load) Test must be performed within 18 hours of charging.
- Vehicle must not be used, even for short runs, prior to Discharge (Load) Test.
- Electrolyte level must be correct in all cells.

**Test Procedure**

**⚠ WARNING**

**Discharge Load Test must be performed in well ventilated area.**

1. Connect tester leads to battery bank.
2. Check and record electrolyte temperature of center cell of each battery.
3. Turn tester on.
4. After 20-30 minutes, with tester on, check and record individual battery voltages to the nearest 0.1 (1/10) volt.

All six individual battery voltage readings must be made as rapidly as possible to be accurate.

5. Allow tester to shut off automatically, and record time elapsed from start of discharge.

Tester shutoff should occur at a battery voltage of 42v +/- 0.2v (48 volt system) or 21v +/- 0.2v (24 volt system). Check tester shutoff voltage periodically. This setting must be accurate for a valid test.



**Results Interpretation**

1. Compare individual battery voltages recorded in step 4 of *Discharge (Load) Test Procedure* and discard any battery that is 0.2 (2/10) volt lower than the highest battery in bank. If defective battery is found, recharge the entire bank for 12 hours. Then, replace the defective battery with a good fully charged battery of the same brand and date code, if possible. Equalize the bank by placing it on charge for an additional three hours, then retest.
2. If all battery voltages are within 0.2 volts of each other, compare discharge time from step 4 of *Discharge (Load) Test Procedure* with minimum times in Temperature and Time Table. Even if individual battery voltages are satisfactory, but the discharge time fails to meet minimums in Temperature and Time table, the entire battery bank should be replaced.

<b>DISCHARGE LOAD TEST: Temperature &amp; Time</b>	
Electrolyte Temperature (Step 2)	Minimum Discharge Time (Step 5)
40-49° F (4-9° C)	40 Minutes
50-59° F (10-15° C)	45 Minutes
60-64° F (16-17° C)	50 Minutes
65-69° F (18-20° C)	54 Minutes
70-74° F (21-23° C)	57 Minutes
75-79° F (24-25° C)	60 Minutes
80-84° F (26-29° C)	62 Minutes
85-89° F (30-32° C)	64 Minutes
90-99° F (33-37° C)	66 Minutes
100-109° F (38-43° C)	68 Minutes
110-119° F (44-48° C)	70 Minutes
120-129° F (49-54° C)	72 Minutes
130-150° F (55-66° C)	74 Minutes

**Table 4**

**STORING BATTERIES**

- Batteries can remain in vehicle.
- Batteries should be fully charged.
- Clean battery tops and connections.
- Fully charged batteries should be stored in as cold of an environment as possible. Batteries “self discharge” when not in use. The colder the temperature, the slower batteries self discharge.

**⚠ CAUTION**

**Batteries in low state of charge (low specific gravity readings) will freeze at higher temperatures than those fully charged.**

Check specific gravity periodically, and recharge batteries as necessary. Batteries stored in temperatures above 80°F (26°C), will discharge faster and require recharge every few weeks. Batteries stored at or below 0°F (-12°C) may not require recharge for periods up to 4 months. When recharging, bring batteries to 1.250-1.270 specific gravity to prevent freezing. See Table 5.

State of Charge	Specific Gravity	F° Freezing point C°		Risk of Sulfation
100%	1.260	-70	-57	Low
75%	1.230	-39	-38	Low
50%	1.200	-16	-26	Low
25%	1.170	-2	-19	Moderate
Discharged	1.110	+17	-8	High

**Table 5**

As ice forms in a freezing battery, the electrolyte expands and can crack the case, ruining the battery. If a battery is allowed to stand or is operated in a discharged condition for a long period of time, lead sulfate may develop on the plates, which is dense, hard and crystalline, and which cannot be electrochemically converted to normal active material again. Lead sulfate formed on the plates during discharge is relatively insoluble as long as the specific gravity of electrolyte is kept above 1.125 specific gravity, but if allowed to drop below this value, the lead sulfate becomes increasingly soluble and may migrate into the pores of the separators and deposit as a white crystalline mass.

Subsequent charging may convert these deposits into stringy metallic lead which may short the positive and negative plates through the areas affected. These small shorts may cause a condition of low cell voltage when battery is allowed to stand idle in less than 25% charged condition.

**REPLACING BATTERIES**

The batteries are located under the rear deck.

**Removing Batteries**

1. Remove nuts, washers and cables, positive lead and negative lead interconnecting batteries.
2. Remove nuts, flat washers, hold down plates and rods.
3. Remove batteries.

**Installing Batteries**

1. Install batteries.
2. Install rods and hold down plates.
3. Install flat washers, nylock nuts.
4. Install nuts, washers and cables, positive lead and negative lead interconnecting batteries.



**EXCESSIVELY DISCHARGED BATTERIES**

**NOTICE:** The Delta-Q Automatic Battery Charger will not charge a dead battery. Each battery will need to be brought up to an acceptable state of charge, and establish that it does not have an internal fault or bad cell. If a battery has remained too long in a discharged state, it may be internally damaged and not capable of accepting a charge. It must be replaced.

If the Delta-Q Battery Charger does not reach the full charging mode, identified by a steady LED in the upper region of the Bar Graph display (18/15/12...), or the RED Fault Light is lit, it may indicate that the minimum voltage is not present to allow the charger to control the charging of the complete set of batteries.

If the electrolyte specific gravity is low (less than 1.140 SG), or the individual battery voltage is less than 10.50 volts for 6 cells, it will need to be recharged with an ordinary automotive style trickle charger at a rate of 3 to 6 amps for several hours each. Follow specific charger instructions. It is not necessary to disconnect the battery cables, as the alligator style clips can be connected to each positive and negative battery post.

**⚠ WARNING**

**Always disconnect the AC power first when moving the positive/negative alligator clips to prevent a spark from igniting the gas emitted from the batteries.**

Be sure to charge all of the batteries in the set. Each battery may require 2-3 hours of charging to bring it back to serviceable condition. Measure the Specific Gravity (SG) of each cell after this charging procedure is completed, to verify that the battery is OK for use. Replace any batteries that can not be re-charged (no change or improvement in SG). After all batteries have been individually charged, and with the temporary automotive charger removed, try operating the Delta-Q Charger again to verify operation. Allow the Delta-Q Charger to complete a full charge cycle for proper equalization of batteries. If the 6 Flash Fault persists; an internal fault may be present and the charger will need to be replaced by a qualified dealer technician. A STEADY RED FAULT LED confirms an internal electrical fault of the Delta-Q, and also requires charger replacement and return.





**Columbia ParCar Corp.**

**Service Manual**

**Section 9 – Traction Drive System**



Columbia / ParCar OEM Parts  
[evtechnicalservices.com](http://evtechnicalservices.com)

**TRACTION MOTOR**

**Maintenance**

A good planned maintenance program will save many hours of future down time and prevent catastrophic failure of major motor components. Maintenance schedules consist of periodic routine inspections of motors, battery and wiring circuitry.

Since operation of equipment varies widely, the following recommendations are suggested for periodic maintenance inspection:

Normal service – 8 hours per day operation

- Routine inspection every 1,000 hours

Severe service – 24 hours of daily operation

- Routine inspection every 500 hours

**NOTICE: Severe service would include; Dusty or sandy locations such as cement plant, lumber or fl our mills, coal dust or stone crushing areas. High temperature areas such as steel mills, foundries, etc. Sudden temperature changes such as continuous indoor-outdoor movement, as in refrigeration plants.**

**External Inspection**

1. Check for clean, tight, terminal studs and mounting bolts.
2. Internal and external spline drives, between motor and final drive axle, must be periodically lubricated with a thin layer of quality, anti-seize compound.
3. Check for any signs of oil leaks from final drive axle, which might cause oil to enter traction motor.

**Internal Inspection**

The brush and commutator inspection is the most important part of motor maintenance. By recognizing undesirable commutator and/or brush conditions, internal repairs can be performed before major component damage or failure occurs.

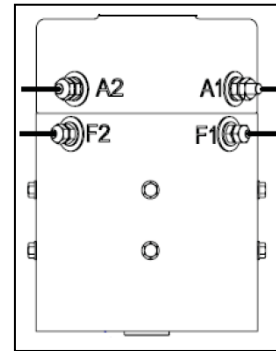
Brush and commutator inspection can be accomplished by removing the motor head. The brushes and commutator should be inspected for even wear and good commutation.

Good commutation will be indicated by a dark brownish, polished commutator and an evenly polished brush wearing surface. If the commutator appears rough, pitted, scored or has signs of burning or heavy arcing between the commutator bars, the motor should be removed for servicing.

**Removal**

**NOTICE: Studs and jam nuts on the electric motor can be damaged when attaching or removing electrical leads. Hold a thin open end wrench on the electrical stud connector jam nut while loosening or tightening attaching nuts.**

1. Mark traction motor cables (if not already marked), with motor terminal identification Figure 9-1.
2. F1 and F2 terminals are 1/4-20, A1 and A2 terminals are 5/16-18. Hold terminal jam nut with a thin open end wrench when loosening and removing hex nuts, lock washers and flat washers securing electrical cables to traction motor.



**Figure 9-1**

3. Carefully support motor to prevent it from falling.
4. Loosen and remove the three 1/4" bolts, lock washers and flat washers securing motor to rear axle/differential housing.
5. Pull motor away from rear axle housing and clear of the vehicle.

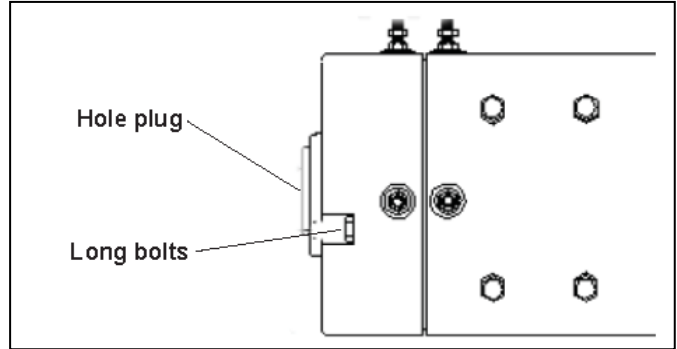
**CAUTION**

**Traction motor is heavy and awkward to move. Get help stabilizing and removal to prevent possible personal injury.**

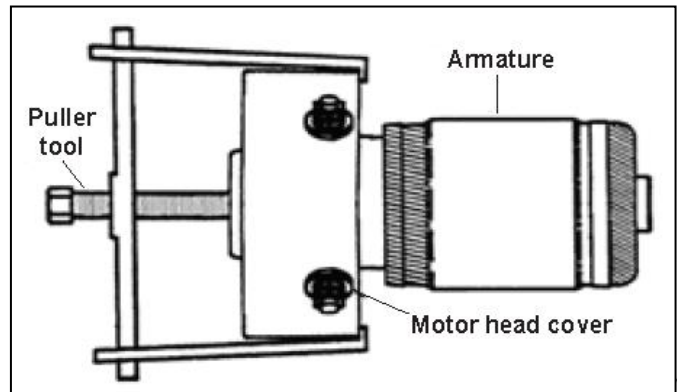
Columbia / ParCar OEM Parts  
 evtechnicalservices.com  
 TECHNICAL SERVICES

**Disassembly**

1. Remove long bolts. Remove motor head hole plug. See Figure 9-3.
2. Pull on motor head to remove armature from frame. A light tap may be required to loosen motor head from frame. Motor head and armature come out together.
3. Place puller around the motor head. Use the center of the shaft to locate puller. See Figure 9-4.
4. Pull motor head assembly off of armature assembly maintaining equal pressure on all sides of head.
5. Move brush springs behind spring hooks shown in Figure 9-5.
6. Remove 1 hex nut, 1 lock washer, 1 hex nut, 1 flat washer and 1 insulator at each brush terminal, A1 and A2. Figure 9-6.
7. Remove 4 brush plate screws (Figure 9-7). Push brush terminal studs through, into the center of the head as the brush box, brushes and terminal assemblies are removed. (See exploded view Figure 9-9).
8. Remove bearing retainer (snap ring) shown in Figure 9-5. Carefully press out the bearing from motor head. Replace the bearing.
9. Remove all the brush dust from motor frame, brush box, and motor head.



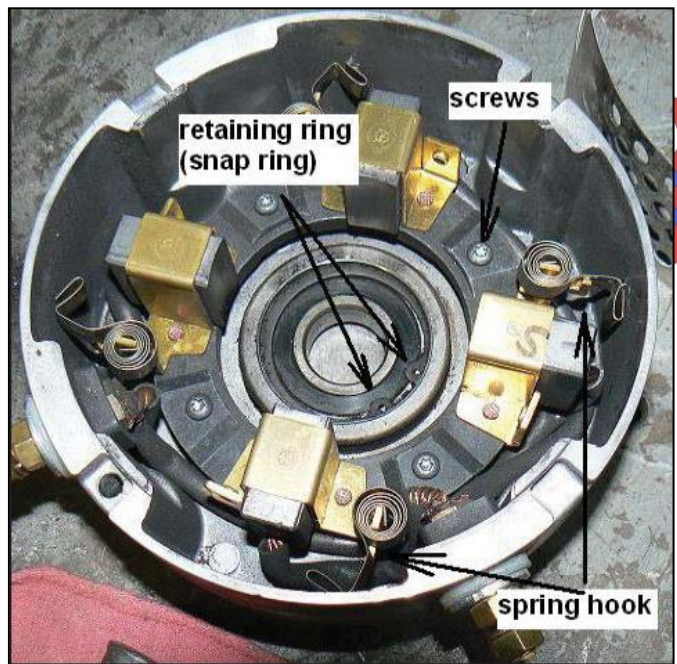
**Figure 9-3**



**Figure 9-4**

**Armature Inspection**

1. Measure the diameter of the armature (Figure 9-8).
  - Max dia. when new 2.92-2.93" (74 mm)
  - Min dia. for re-slotting 2.81" (71 mm)
  - Replacement dia. 2.76" (70 mm)
2. Support the armature at both bearing journals. Check runout of commutator with a dial indicator. Total indicated runout should not exceed 0.005" (0.12 mm). If the readings fall outside this limit, commutator must be turned and undercut. Figure 9-10.
3. After the commutator has been undercut, if required, the armature should be placed in lathe and the commutator lightly sanded with no. 00 sandpaper. This will remove any burrs left from the undercutting operation.
4. Clean commutator with dry, compressed air. Recheck commutator runout.



**Figure 9-5**

**Armature Testing**

Before the armature is reassembled into the motor, the following test should be performed.

1. Check armature for grounded circuits by placing one test lead of a Dielectric Breakdown Tester, also referred to as a “growler”, on the commutator and other lead at armature shaft. The ground test light should not flash. A flash indicates failed insulation between core and armature wiring. See Figure 9-11.
2. For short circuit connection, use a hacksaw blade to locate any shorted windings. Rotate armature slowly in growler jaws and hold a hacksaw blade in parallel against top of armature. The steel blade will be attracted to the core and will vibrate when two shorted armature coils are located. See Figure 9-12.

**Brushes**

Brushes should be inspected for uneven wear and signs of overheating, such as discolored brush leads and brush springs. Check brush box for physical damage. Make sure brush holders are not loose on the brush box assembly. See Figure 9-9.

Check brush for correct clearance and freedom of movement in the holder.

New brush length: 1.20" (30.5 mm)

Minimum brush length: 0.60" (15.2 mm)

Replacement brush length: less than 0.60" (15.2 mm) If any brushes are worn to the point that replacement is necessary, the complete brush set should be replaced. Never replace just one pair of brushes.

Do not substitute brushes. The brushes are matched to the motor type and application to provide the best service. Substituting brushes of the wrong grade can cause commutator damage or excessive brush wear.

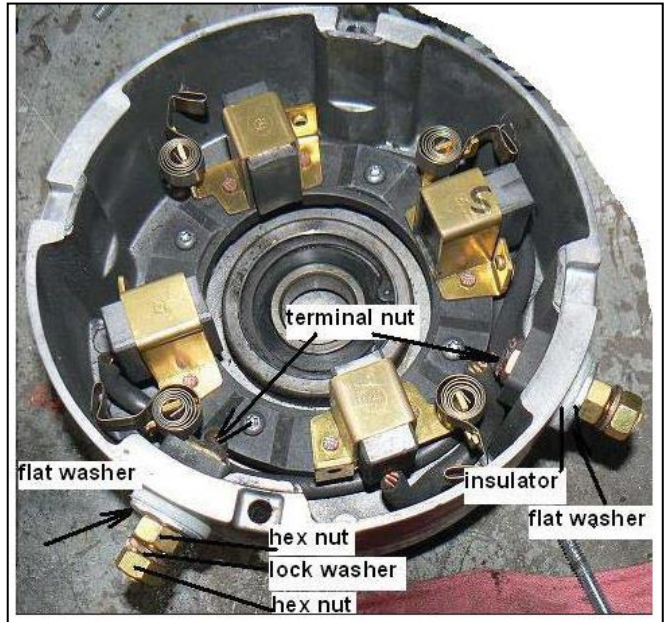
**Brush Springs**

Check the brush springs for correct alignment on the brush. A brush spring that does not apply equal pressure on the center of the brush will cause the brush to wear unevenly.

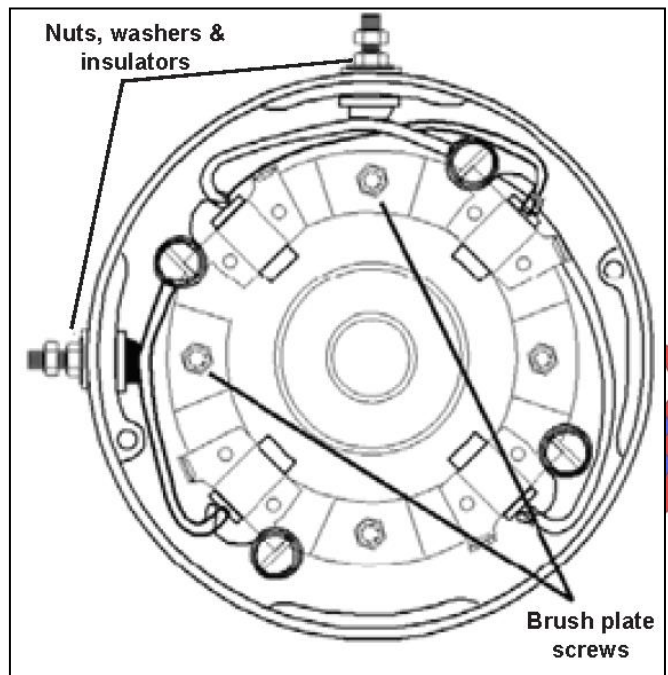
Use the following procedure for checking brushes for proper tension. See Figure 9-13.

1. Place paper strip between brush face and commutator.
2. Hook a commercial spring scale as shown.
3. Pull spring scale on a line directly opposite the spring force. When paper strip can be moved freely, read spring tension on scale.

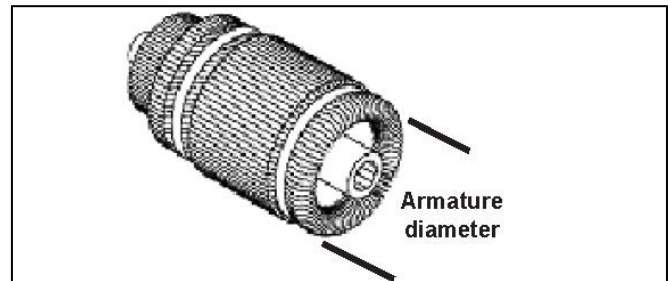
Brush spring tension      New 64 ounces (1792 grams)  
    Worn 40 ounces (1120 grams)



**Figure 9-6**

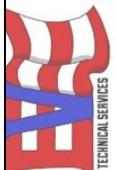


**Figure 9-7**



**Figure 9-8**

Columbia / ParCar OEM Parts  
 evtechnicalservices.com





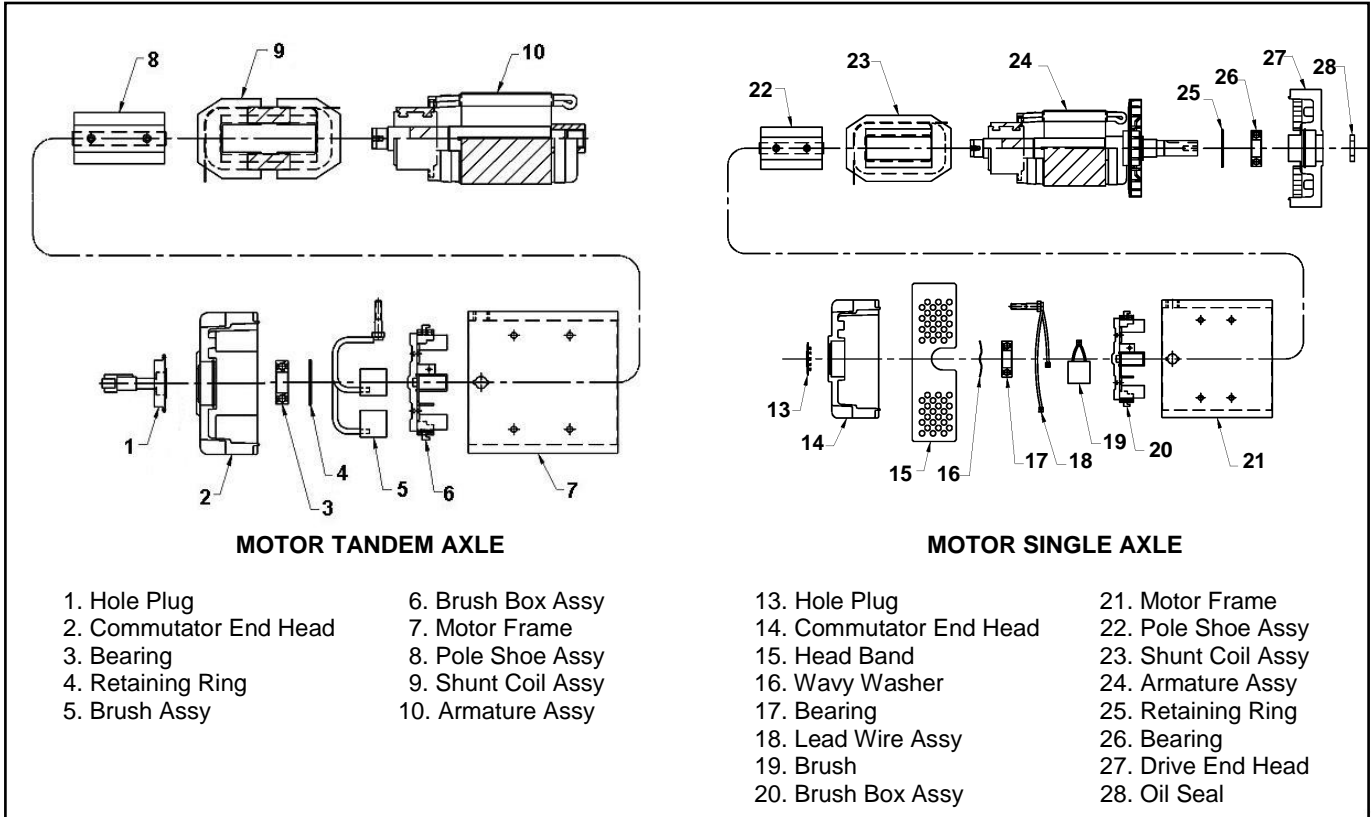


Figure 9-9

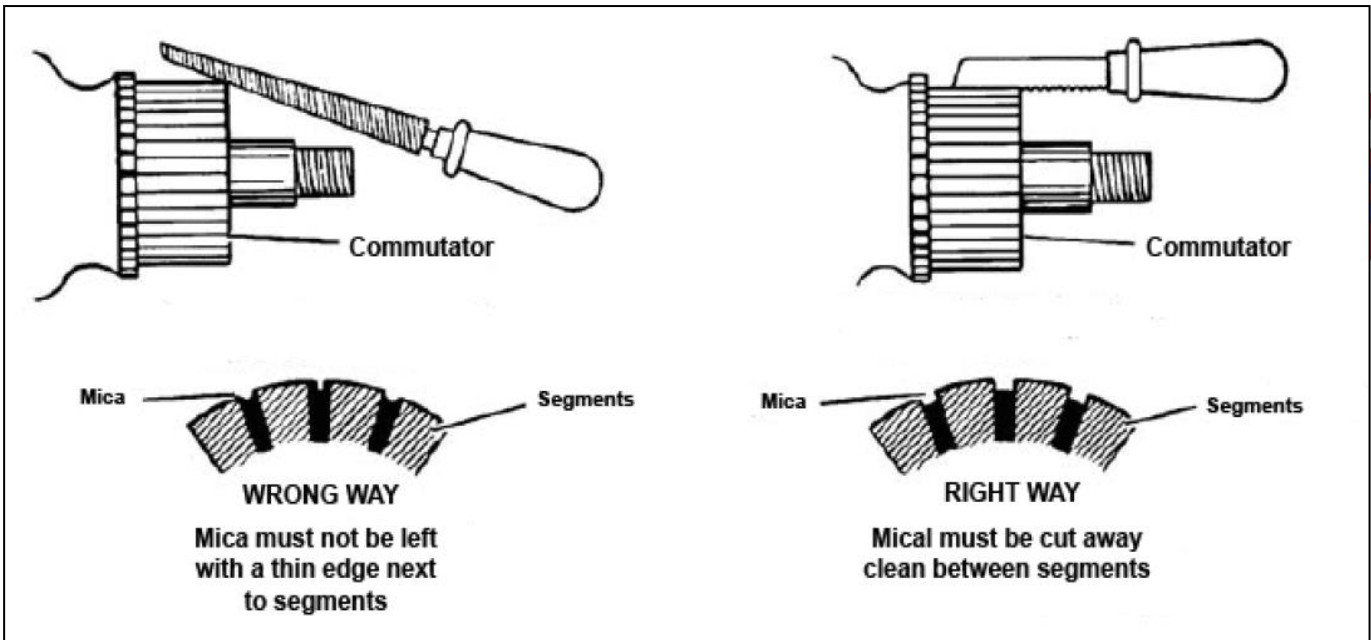
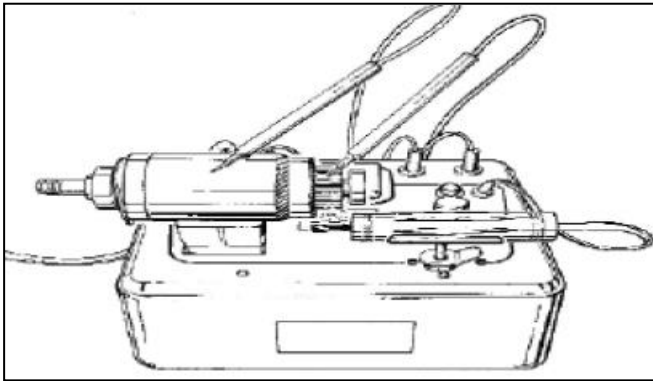


Figure 9-10



**Figure 9-11**

**Bearing**

After the motor has been disassembled, it is recommended that a new bearing be installed. Bearing may appear and feel ok, however, bearing may have been damaged during removal.

**Frame and Field Coils**

**NOTICE: Do not remove the field coils (9 & 23, Figure 9-9), from the motor frame unless it is absolutely necessary for repair. Removal and re-installation could shorten field coil life.**

There should be no continuity between the frame of the motor and field coil (Figure 9-9). Set the volt ohm meter (VOM) to measure Ohms. See Figure 9-14.

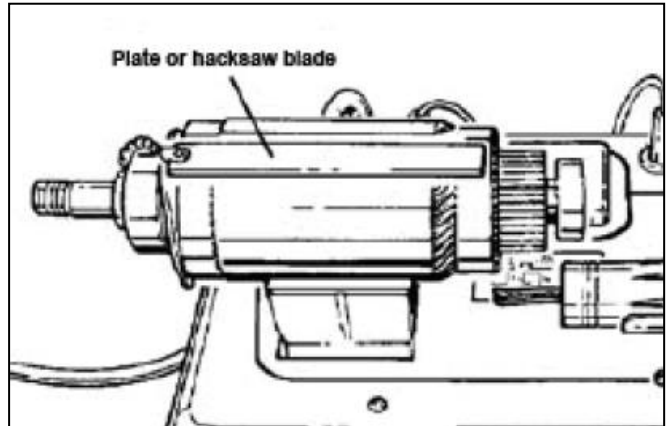
**Field Coil Maintenance** NOT recommended by Columbia.

**Inspection**

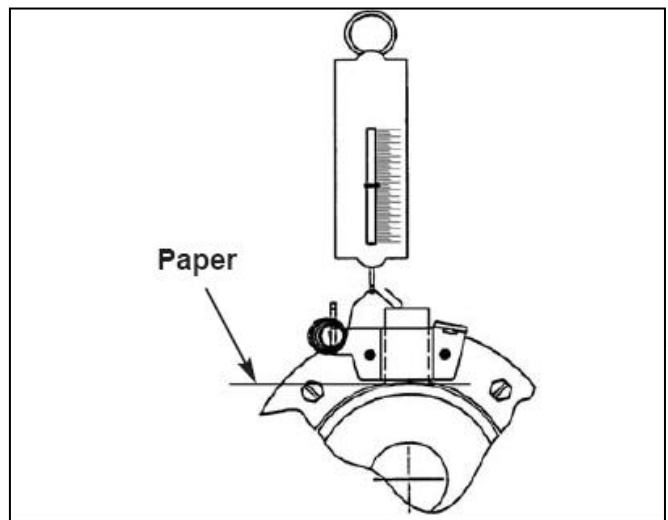
Motors that have been disassembled for servicing should also include a complete inspection of the frame and field assembly. It is not uncommon for the frame and field assembly of a motor to become exceptionally dirty after many hours of operation. This may result in a grounding condition due to dirt, grease and other foreign materials.

**Motor Reassembly**

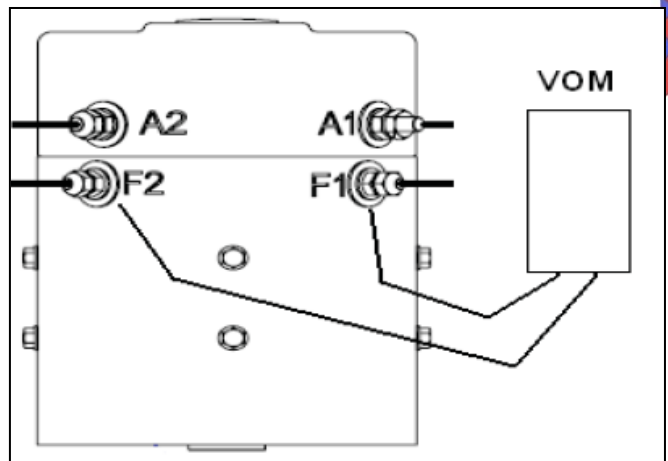
1. Always use a new bearing when reassembling a motor. Press bearing into motor head. Press only against the outer race. See Figure 9-15. Install snap ring to retain bearing. Figure 9-16.
2. Assemble brush assemblies into brush box assembly.
3. Position brush holder into motor head as shown in Figure 9-16. Make sure that the terminals for the brushes are loose and free.
4. Install insulators and brush leads into motor head. See Figure 9-17. Brush motor terminals, A1 and A2, should be torqued to 140 in. lbs. (15.8 Nm).



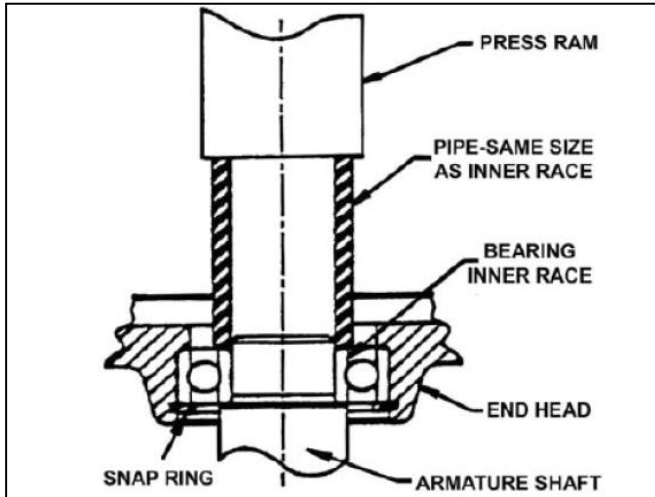
**Figure 9-12**



**Figure 9-13**



**Figure 9-14**



**Figure 9-15**

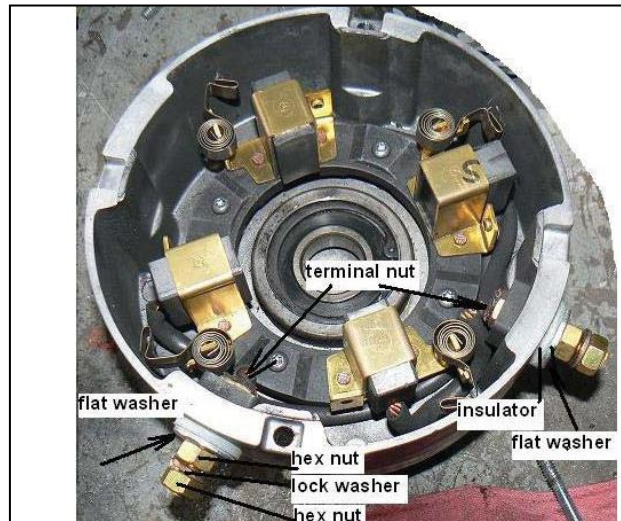
5. Pull back each brush in its holder, allowing the spring to rest against the side of each brush. This will hold each brush in place, preventing interference and damage to commutator and brushes during armature installation.
6. Press motor head and bearing onto armature, pressing only against inner race of the bearing. See Figure 9-15.
7. Check that head and bearing rotates freely, without noise or irregular interference. Press brushes inward against armature commutator. Relocate the springs to push on the brushes. Check that brushes ride smoothly on the commutator.
8. Install motor head and armature assembly into field coil and frame assembly, aligning armature terminals to field coil terminals.
9. Install two bolts securing motor head to frame. Make certain motor head is completely seated to the frame before tightening. Torque bolts to 156 in. lb. (17.6 Nm).

**Motor Installation**

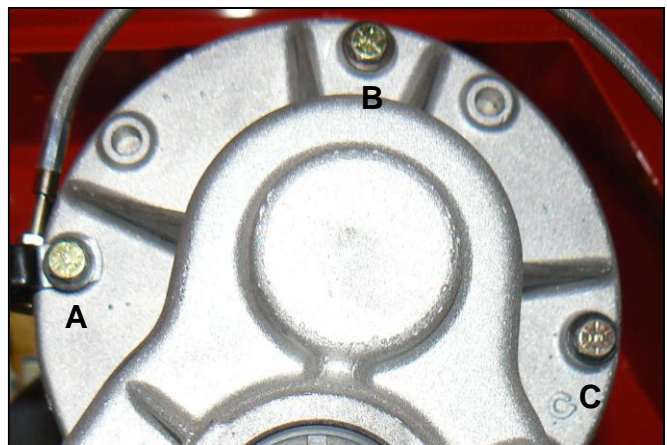
1. Coat open end of the armature and rear axle input shaft with Anti-Seize compound. Insert a new rubber bumper into open end of armature. Place motor into vehicle and onto input shaft.
2. Rotate motor to align mounting bolt holes to axle/differential housing. Install 3 bolts securing motor to rear axle/differential housing, while carefully supporting motor to prevent it from falling. Loosely tighten screws A and B, then loosely tighten screw C to draw face of motor up to flange on axle evenly (Figure 9-18). Torque screws A and B to 100 in. lbs. (11.3 Nm) Then tighten screw C to 100 in. lbs. (11.3 Nm).
3. Inspect electrical system cables for terminal identification (A-1, A-2, etc.). Position cables to traction motor, double checking wiring diagram to motor cable installation to ensure connections are correct.



**Figure 9-16**



**Figure 9-17**

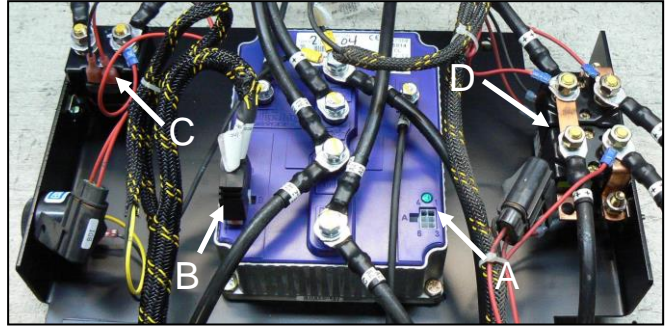


**Figure 9-18**

- F1 and F2 terminals are 1/4-20 while A1 and A2 terminals are 5/16-18. Attach cables with flat washers, lock washers and hex nuts. Torque A1 & A2 cable attaching nuts to 110 in. lbs. (12.4 N m), while holding the bottom nut, with a thin open-end wrench. Torque F1 & F2 cable attaching nuts to 50 in. lbs. (5.7 Nm), while holding the bottom nut, with a thin open end wrench.
- Place vehicle on the ground or onto dynamometer to test motor operation.

**CAUTION**

**Do not run motor at full voltage without a load.**



**Figure 9-19 Tandem Battery Pack**

**CONTROLLER**

**ACEplus System**

The ACEplus System is an advanced traction drive system that uses a fully integrated, solid state Sevcon Controller for speed regulation and forward/reverse control. Combined with a separately excited DC motor, the system provides optimized power efficiency through pedal proportional speed control and regenerative braking. This control system is ideal for hilly terrain or areas with multiple ramps. It is also used for towed loads and high braking demands. The ACEplus system is distinguished by a 6 post controller. See Figure 9-19.

**Testing**

Do not remove the controller. It can be tested while still in the vehicle. It is accessed from under the vehicle.

- Look for the steady green light on the controller. If it is on, the system is OK and ready (Figure 9-19A).
- If it is flashing, count the number the flashes in each sequence. Refer to *Section 4 - Troubleshooting* for controller flash troubleshooting info, and for info on testing controller with Sevcontrol Calibrator or PC Pak computer interface.
- If the tests indicate that the controller has failed, replace it.

**Removing**

- Disconnect battery negative cable and remove Power key.
- Label/mark controller cables with controller terminal identification, if not already labeled.

**NOTICE: The controller terminal bolts and washers are Metric. Metric wrenches are required to remove the controller cable fasteners. The fasteners that attach the controller to the vehicle frame are SAE U.S.**

- Remove six metric bolts, lock washers, flat washers and all the cables and wires connected to the controller.
- Remove 16 pin controller connector (Figure 9-19B).

See *Columbia Service Bulletin 06-010* if the wiring harness or connector are damaged.

- Remove four nuts, washers and bolts securing controller to the mounting panel.

**NOTICE: Do not attempt to disassemble the controller. There are no repairable parts inside.**

**Installing**

- Position controller mounting panel and secure with four bolts, washers and nuts.
- Install cables to controller terminals according to cable identification labels. Make sure there is a flat washer under the terminal ends of the cables. This will spread the load and help prevent the terminal ends from folding over.
- Torque controller cable attaching bolts to 50 – 60 in. lbs. (5.7 – 6.8 Nm).
- Reconnect battery negative cable. Insert Power key in switch and check for steady green light on controller.
- Perform an operational check of the vehicle's driving abilities

**CONTACTOR(S)**

Contactors are electro-magnetic switches that energize when current is applied to the small control circuit terminals. When energized, the solenoid core moves up from magnetism created by the coil and internal contacts, creating a connection between two large terminals, allowing current to pass through.

When control circuit voltage is removed from the small terminals, the magnetic field collapses and a spring returns the core to its rest position. A contact solenoid in the normal position has an open circuit between the large terminals, preventing current from passing through it.

The contactor is located on the mounting panel next to the controller (Figure 9-19C). Vehicles with tandem battery pack will also have a double 48V coil contactor (Figure 9-19D).

**Removing**

1. Label contactor cables with terminal identification. Refer to schematic for correct wire numbers.
2. Remove two nuts, washers and cables from stud terminals.
3. Remove control circuit wires from spade terminals.
4. Remove two nuts, washers, bolts and contactor.

**Installing**

1. Position new contactor to mounting bracket.
2. Secure contactor to mounting plate with two bolts, nuts and washers.
3. Install heavy cables to stud terminals. Install control circuit wires to spade terminals. Double check wiring diagram to ensure connections are correct.
4. Operational Check: Contactor should emit an audible click when the power key switch is set to ON position.