



# **SERVICE MANUAL**

**Electric EU - C6 - C10**

**Models**

## GENERAL

This service manual has been prepared with two purposes. First, it will introduce the trained maintenance professional to the latest field tested and factory approved major repair methods. Secondly, it will acquaint the reader with the construction of the Columbia ParCar vehicles and assist him/her in performing basic maintenance and repair. We sincerely believe that this manual will make the association with Columbia ParCar vehicles a more pleasant and profitable experience.

In addition to the information given in this manual, Service Bulletins are issued to Columbia ParCar dealers, which cover interim engineering changes and supplementary information. Service Bulletins should be consulted for complete information on the models covered by this manual.

To ensure the safety of those servicing our vehicles and to protect the vehicles from possible damage resulting from improper service or maintenance, the procedures in this manual should always be followed exactly as specified. Execution of the procedures and troubleshooting tips as outlined will ensure the best possible service from the vehicle(s). To reduce the chance of personal injury and/or property damage, carefully observe the DANGER, WARNING, CAUTION & NOTICE recommendations throughout this manual. See *Section 1-Safety* for additional details.

## PREPARATION FOR SERVICE

Proper preparation is very important for efficient service work. A clean work area at the start of each job will allow you to perform the repair as easily and quickly as possible, and reduce the incidence of misplaced tools and parts. Columbia ParCar vehicles that are excessively dirty should be cleaned before work begins. Cleaning will occasionally uncover trouble sources. Tools, instru-

ments and parts needed for the job should be gathered before work is started. Interrupting a job to locate tools or parts is a needless delay. Special tools required for a job are listed at the beginning of each section.

## MODEL IDENTIFICATION

Always give the vehicle identification number (VIN) when ordering parts or making inquiries about the vehicle. Use of the full and complete vehicle identification number will ensure that the dealer or service provider is supplying you with the correct parts for the vehicle. See *Section 2-General Information* for VIN location and additional information.

## USE GENUINE REPLACEMENT PARTS

### ▲ WARNING

**When replacement parts are required, use only genuine Columbia ParCar parts or parts with equivalent characteristics including type, strength and material. Failure to do so could result in product malfunction and possible injury to the operator and/or passenger.**

To ensure a satisfactory and lasting repair job, follow the service manual instructions carefully and use only genuine Columbia ParCar vehicle replacement parts. This is the insurance that the parts you are using will fit right, operate properly and last longer. When you use genuine Columbia ParCar vehicle parts, you use the best.

## PRODUCT REFERENCES

When reference is made in this manual to a specific brand name product, tool or instrument, an equivalent product, tool or instrument may be used in place of the one mentioned.

Columbia ParCar  
evtechnicalservices.com



**SECTION 1 - SAFETY**

Overview..... 1-2  
 Safety Information ..... 1-2  
 Safety Preparations ..... 1-3  
 Icons in Procedures..... 1-4  
 Decals..... 1-4

**SECTION 2 - GENERAL INFORMATION**

Model information ..... 2-2  
 Vehicle Model Information ..... 2-2  
 Vehicle Identification Number (VIN) Charts..... 2-2  
 Safety Committee ..... 2-2  
 Vehicle Specifications..... 2-3  
 Controls and Operation ..... 2-4  
 Location of Controls ..... 2-4  
 Operation..... 2-4  
 Pre-operation Inspections..... 2-5  
 Pre-operation Check List..... 2-5

**SECTION 3 - MAINTENANCE**

Periodic Maintenance ..... 3-2  
 Batteries ..... 3-5  
 Chassis Lubrication ..... 3-5  
 Wheel Hubs..... 3-5  
 Brake Pedal..... 3-5  
 Rear Axle ..... 3-5  
 Chassis Cleaning..... 3-5  
 Seat Cleaning ..... 3-5  
 Lifting instructions..... 3-6  
 Tools Required ..... 3-6  
 Hoist Lifts ..... 3-6  
 Floor Jack Procedure ..... 3-6  
 Jack Stands..... 3-6  
 Vehicle Storage ..... 3-7  
 Returning Vehicle to Service ..... 3-7  
 Towing the Vehicle..... 3-7  
 Transporting the Vehicle..... 3-7  
 Torques and Metric Conversion Factors..... 3-8

**SECTION 4 - TROUBLESHOOTING**

Pre-Troubleshooting Steps..... 4-2  
 Battery Testing..... 4-3  
 Troubleshooting Specific Complaints ..... 4-4  
 ACEPlus Sevcon Controller Power System ..... 4-8  
 Smartdrive Sevcon Controller Power System ..... 4-12  
 Speed Switch (Pot Box) Testing ..... 4-14  
 Component Troubleshooting ..... 4-14

**SECTION 5 - ACCELERATOR AND BRAKES**

Accelerator Pedal ..... 5-2  
 Mechanical Brake System ..... 5-2  
 General..... 5-2  
 Periodic Brake Inspection..... 5-2  
 Annual Brake Inspection ..... 5-2  
 Mechanical Rear Drum Brake ..... 5-3  
 Brake Cable Replacement ..... 5-5  
 Mechanical Brake Adjustments ..... 5-5  
 Hydraulic Brake System ..... 5-6  
 General..... 5-6  
 Periodic Brake Inspection..... 5-6  
 Annual Brake Inspection ..... 5-6  
 Hydraulic Rear Drum Brake ..... 5-6  
 Hydraulic Master Cylinder ..... 5-9  
 Hydraulic Front Disc Brake ..... 5-10  
 Hydraulic Brake Adjustments ..... 5-12

**SECTION 6 - FRONT WHEELS, STEERING & FRONT SUSPENSION**

General..... 6-2  
 Specifications ..... 6-2  
 Front Wheels and Hubs..... 6-2  
 Removing Front Wheels and Hubs ..... 6-2  
 Inspecting/Replacing Wheel Hub Bearings ..... 6-2  
 Installing Front Wheel Hubs and Wheels ..... 6-2  
 Tires..... 6-4  
 General..... 6-4  
 Removing Tire ..... 6-4  
 Installing Tire ..... 6-4  
 Steering Wheel..... 6-5  
 Removing Steering Wheel..... 6-5  
 Installing Steering Wheel..... 6-5  
 Rack and Pinion Steering Assembly..... 6-5  
 Removing Rack and Pinion Steering Assembly ..... 6-5  
 Disassembling Rack and Pinion Steering Assembly ..... 6-5  
 Assembling Rack and Pinion Steering Assembly..... 6-6  
 Installing Rack and Pinion Steering Assembly ..... 6-6  
 Front Suspension System ..... 6-6  
 Replacing Shock Absorbers ..... 6-6  
 Replacing Front Leaf Spring..... 6-6  
 Disassembling Kingpin, Steering Arm and A-Arm ..... 6-6  
 Assembling Kingpin, Steering Arm and A-Arm ..... 6-7  
 Steering and Front suspension Adjustments ..... 6-7  
 Camber Adjustment..... 6-7

Columbia / ParCar OEM Parts  
 evtechnicalservices.com  
 TECHNICAL SERVICES

Toe In Adjustment.....	6-7	Battery Service (Water) .....	9-4
<b>SECTION 7 - REAR WHEELS, REAR SUSPENSION &amp; AXLE ASSEMBLY</b>		Battery Charging.....	9-5
Rear Wheels.....	7-2	Delta-Q Charger Operation .....	9-8
Removing Rear Wheels .....	7-2	REd Light Charger Error Codes .....	9-8
Rear Axle Wheel Bearings .....	7-2	Charging Procedure .....	9-9
Installing Rear Wheels .....	7-2	Special Charging Procedure for Excessively Discharged Batteries .....	9-10
Tires.....	7-2	Testing Batteries .....	9-10
Rear Suspension.....	7-2	Storing Batteries .....	9-12
Replacing Rear Shock Absorbers .....	7-2	Replacing Batteries .....	9-12
Replacing Rear Springs .....	7-2	Battery Charger .....	9-12
Replacing Rear Frame Bushings .....	7-3	<b>SECTION 10 - TRACTION DRIVE SYSTEM</b>	
Rear Axle Assembly.....	7-3	Traction motor .....	10-2
Removing Rear Axle.....	7-3	Maintenance.....	10-2
Disassembling Rear Axle .....	7-6	External Motor Inspection.....	10-3
Assembling Rear Axle .....	7-9	Internal Motor Inspection.....	10-3
Installing Rear Axle.....	7-11	Traction Motor Removal .....	10-3
Rear Axle Differential Oil .....	7-12	Traction Motor Disassembly.....	10-3
Changing Differential Oil .....	7-12	Armature Inspection .....	10-6
<b>SECTION 8 - BODY AND CHASSIS</b>		Armature Testing .....	10-6
Front Body.....	8-2	Brushes .....	10-6
Replacing Front Headlight Bulb.....	8-2	Brush Springs.....	10-6
Replacing Front Turn Signal Bulb.....	8-2	Bearing.....	10-6
Front Bumper.....	8-3	Frame and Field Coils .....	10-6
Back Rests and Frame.....	8-3	Field Coil Maintenance .....	10-6
Seat Cushion and Handrails.....	8-4	Inspection .....	10-6
Center Body.....	8-4	Traction Motor Reassembly .....	10-6
Bag Rack.....	8-5	Traction Motor Installation .....	10-7
Tail Lights and Rear Turn signals .....	8-5	Controller .....	10-8
Rear Body.....	8-6	Smartdrive Traction Motor System.....	10-8
Rear Bumper .....	8-6	ACEplus Traction Motor System .....	10-8
Console Controls.....	8-6	Controller Testing .....	10-8
Replacing Power On Off Key Switch.....	8-6	Removing the Controller .....	10-8
Replacing Directional Key switch .....	8-7	Installing the Controller.....	10-9
Replacing Head Light Switch .....	8-7	Contactor/Solenoid.....	10-9
Replacing Battery Discharge Indicator (BDI).....	8-7	Removing the Contactor.....	10-9
Steering Wheel.....	8-7	Installing the Contactor .....	10-9
Horn.....	8-8		
Turn Signal / Emergency Flasher Control .....	8-8		
<b>SECTION 9 - BATTERIES AND BATTERY CHARGER</b>			
Safety .....	9-2		
General Information.....	9-3		
Battery Inspection.....	9-3		
Battery Cleaning.....	9-3		



THIS PAGE INTENTIONALLY LEFT BLANK.

**OVERVIEW ..... 1-2**  
**SAFETY INFORMATION ..... 1-2**  
**SAFETY PREPARATIONS ..... 1-3**  
**ICONS IN PROCEDURES ..... 1-4**  
**DECALS..... 1-4**



**OVERVIEW**

Statements in this manual preceded by the words **DANGER**, **WARNING**, **CAUTION** or **NOTICE** and words printed in **bold face** are very important. We recommend you take special notice of these items.

It is important to note that some warnings against the use of specific service methods, which could damage the vehicle or render it unsafe, are stated in this service manual. However, please remember that these warnings are not all inclusive. Since Columbia ParCar Corporation could not possibly know, evaluate and advise servicing personnel of all possible ways in which service might be done or of the possible hazardous consequences of each way, we have not undertaken any such broad evaluation.

Accordingly, anyone who uses a service procedure or tool which is not recommended by Columbia ParCar must first thoroughly satisfy him/herself that neither their nor the operator's safety will be jeopardized by the service methods selected.

**▲ DANGER**

Danger indicates a hazardous situation which, if not avoided, **WILL** result in death or serious injury to the operator or bystanders.

**▲ WARNING**

Warning indicates a hazardous situation which, if not avoided, **COULD** result in death or serious injury to the operator or bystanders.

**▲ CAUTION**

Caution indicates a hazardous situation which, if not avoided, **MAY** result in moderate or minor injury to the operator or bystanders.

**NOTICE**

Notices are messages not related to personal injury. They will provide key information to prevent property damage and to ensure procedures are more easily understood or implemented.

**SAFETY INFORMATION**

It is Columbia ParCar's specific recommendation that the following safety information must be observed at all times. Not all are repeated throughout this manual, but the recommendations included must be observed whenever these subjects (indoor vehicle operation hazards are encountered.

**▲ DANGER**

Any modifications or changes to the vehicle that affect the stability or increases vehicle speed beyond factory specifications could result in severe personal injury or death.

Always, remove keys and disconnect the batteries before servicing or repairing your vehicle. See *Section 8-Batteries*, for specific details.



All batteries used in electric vehicles can explode! Always wear full face shield when working on or near batteries. Hydrogen fumes are a natural byproduct of charging and discharging and are extremely explosive.



Do not smoke around electric vehicle batteries. Keep sparks and flames away from batteries. Battery charging should only be done in a well-ventilated area. Refer to *Section 9-Batteries* for details.



Batteries contain acid which can cause severe burns. Causes severe burns. Avoid contact with skin, eyes, or clothing. Wear full face shield and rubber gloves when working on or near batteries.

**ANTIDOTES:**

- External: Flush with water. Call a physician immediately.
- Internal: Drink large quantities of milk or water. Follow with milk of magnesia or vegetable oil.
- Eyes: Flush with water for fifteen minutes. Call a physician immediately.

When working around batteries, use approved insulated tools, remove jewelry such as rings, watches, chains, etc. and place an insulating material such as wood, plastic, rubber, etc. over batteries covering all connections.

If any problems are found during scheduled maintenance or inspections, Do not operate vehicle until repairs are made. Failure to make necessary repairs could result in fire, property damage, severe personal injury or death.

**▲ WARNING**

Only trained maintenance professionals should repair or service this vehicle. Persons doing even simple repairs or service should have working knowledge and experience in general electrical and mechanical repair. Follow all procedures exactly and observe all warnings stated in this manual. Use caution and common sense.

Proper service and repair is important for safe, reliable operation of all Columbia Industrial/Commercial vehicles. The service procedures recommended and described in this service manual are effective methods for performing service operations. Some of these service operations require the use of tools specially designed for this purpose. These special tools should be used when and as recommended.

Use insulated tools when working near batteries or electrical connections. Use extreme caution to avoid shorting of components or wiring.



**Moving parts hazard!** Watch for international symbol icons in the margins. When operating any vehicle in a stationary position, avoid chains, belts, and wheels which could snag clothing or cause severe injury to body parts. A running vehicle must be worked on with the greatest care. Use caution and common sense.

Do not wear loose clothing or jewelry such as rings, watches, chains, etc. when servicing the vehicle. Failure to do so could result in personal injury or death.

Working on Columbia ParCar vehicles without following proper procedures and using proper lifting equipment may result in vehicle damage or personal injury. See *Section 3 - Lifting Instructions* detailed instructions.

Always wear safety glasses or approved eye protection while servicing vehicle. Wear a full face shield when working with batteries.

Failure to maintain vehicle properly could result in decreased vehicle performance, reliability or cause severe personal injury.

Exceeding rated vehicle load capacities could result in possible severe injury or property damage.

Check the vehicle for proper location and condition of all vehicle safety and operation decals. Refer to pages 1-4 & 1-5 for locations.

The modification of vehicles for use in other than its intended purpose is not recommended. Any unauthorized modification may void your vehicle warranty.



**HOT! DO NOT** attempt to service hot electric motor or resistors. Failure to observe this warning could result in severe burns.

**CAUTION**

Golf car vehicles are designed to transport one (1) operator and one passenger unless adequate provisions have been factory installed to accommodate additional passengers.

Never exceed the rated load capacity or vehicle stability, reliability and control will be reduced. See vehicle identification plate for capacities and gross vehicle weights.

Cautions appear throughout this manual indicating possible hazards or unsafe practices that may result in minor personal injury, damage to vehicles or property.

**SAFETY PREPARATIONS**

**SAFETY FIRST**

**Always turn Power key to OFF, Directional key switch to Neutral, remove Power key, block tires and disconnect the battery negative (-) cable before performing any vehicle service to avoid accidental startup of vehicle and possible personal injury.**

Parts  
Columbia / ParCar  
evtechnicalservices.com



**ICONS IN PROCEDURES**

Watch out for icons and symbols in procedures. They are there to help you avoid situations that might expose you to an unnecessary hazard or potential injury

**DECALS**

Safety, Warning and Informational decals should be ordered and replaced as soon as they are discovered to be illegible or missing. Refer to Parts Manual or web site for part numbers and ordering info.

Refer to Figures 1-1 for location of the decal.

1. Use a heat gun or hair dryer to soften up and remove any damaged sticker.
2. Peel off backing and carefully position and press decal into place.



**Figure 1-1. Warning and Operating Instructions Decal on Console**

Columbia / ParCar OEM Parts  
evtechnicalservices.com  
EVS TECHNICAL SERVICES



**MODEL INFORMATION ..... 2-2**

    Vehicle Model Information ..... 2-2

    Vehicle Identification Number (VIN) Charts ..... 2-2

**SAFETY COMMITTEE..... 2-2**

**VEHICLE SPECIFICATIONS ..... 2-3**

**CONTROLS AND OPERATION..... 2-4**

    Location of Controls ..... 2-4

    Operation..... 2-4

**PRE-OPERATION INSPECTIONS ..... 2-5**

**PRE-OPERATION CHECK LIST ..... 2-5**

Columbia / ParCar  
 EV Parts  
 evtechnicalservices.com  




**MODEL INFORMATION**

**Vehicle Model Information**

Model	Group Identifiers VIN Digits 1-3	Name	Use Type	Power System
P4E-LE	P4L	Eagle	Golf Car	Battery 48 Volt
P4E-SE	P4S	Eagle	Golf Car	Battery 48 Volt

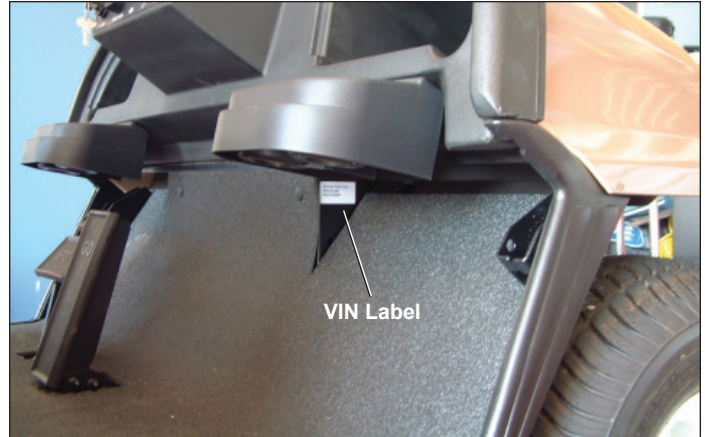
**Vehicle Identification Number (VIN) Charts**

<b>Digit 1 - 3</b> Model Identifier	P4L P4S
<b>Digit 4</b> Power System	A = Series, Resistor B = Series, Solid State C = Separately Excited Plug, Smartdrive D = Separately Excited Plug, High Power, Smartdrive E = Separately Excited Regenerative, ACEplus F = Separately Excited Regenerative with encoder, ACEplus
<b>Digit 5</b> System Voltage	1 = 12V 2 = 24V 3 = 36V 4 = 48V (8 - 6V) B = 48V (4-12V) D = Dual 48V (8-6V / 8-6V) G = 48V GEL (8-6V)
<b>Digit 6</b> Standard or Special Product	(-) = Standard (#) = Special
<b>Digit 7</b> Controller Amperage	3 = 300 Amp 4 = 400 Amp 5 = 500 Amp
<b>Digit 8</b> Axle/Brake System	Z = H12: Rear mechanical Y = H12: Rear Hydraulic X = H12: Front and Rear Hydraulic
<b>Digit 9</b> Year Built	E = 2006 F = 2007 G = 2008 H = 2009

**NOTICE**

**Always provide the complete VIN when contacting your dealer for technical assistance or maintenance and repair parts.**

**The VIN is printed on a white label, affixed to the frame, under the dash (Figure 2-1). It is also affixed to the steering wheel under the steering wheel cover (Figure 2-2).**



**Figure 2-1. VIN Location on Under Dash**



**Figure 2-2. VIN Location on Steering Wheel**

**SAFETY COMMITTEE**

If the vehicles are to be operated by renters or company employees, we recommend that a safety committee be appointed. The primary concern of this committee should be the safe operation of the vehicles.

Subjects which must be considered include, but are not limited to, the following:

- Define where the vehicles should and should not be driven and utilized.
- Ensure all proper warnings as to driving hazards are properly displayed and visible.
- Safety signage concerning hills, turns, blind crossings or intersections is highly recommended.
- Enforcement of safe driving and operating rules.
- Provide driver training for first time operators, and review safe operating recommendations regularly.
- Maintain vehicles in a safe operating condition. Maintain a schedule for daily, weekly, and monthly vehicle inspections.

- Determine who, when and how pre-operation inspections should be conducted.
- Enforcement of safe driving and operating rules.
- Define who should and who should not drive the vehicles.
- Decide what to do should an unsafe condition or operating problem be discovered.
- Enforce that vehicle should not be operated by persons under

the age of 16. These basic rules of operation, combined with courtesy and common sense, will help make driving your Columbia ParCar Vehicles a safe and pleasant experience.

### VEHICLE SPECIFICATIONS

Columbia ParCar Corporation reserves the right to change specifications, equipment or designs at any time without notice and without incurring obligations.

Item	Specifications	Vehicle	
		P4E-LE	P4E-SE
	Power Source		
Motor	48 volt, 15.3 hp @ 1750 rpm 48 volt, 17.3 hp @ 1975 rpm	√	- √
Drive	Direct coupled to oil bath, helical geared, rear axle	√	√
Speed Control	Programmable, solid state, reduced speed reverse with diagnostic LED and calibrator interface	√	√
Rear Axle	12.44:1 helical gear reduction with integral differential 10.35:1 helical gear reduction with integral differential	√ -	- √
Batteries Deep Cycle	48 Volt: 8 - 6 volt, heavy duty, 225 Ah	√	√
Charger	Built in, micro-processor control, fully sealed, anti-drive away interlock, 110-240 V AC, 50/60 Hz	√	√
Directional Control	Console mounted Safety Directional Keyswitch with F (forward), R (reverse) and N (neutral)	√	√
Brakes	Spring applied, auto-adjusting mechanical drum on rear wheels, foot operated parking brake. Optional rear self-adjusting hydraulic brake with hand-operated mechanical parking brake. Optional front hydraulic brakes.	√	√
Steering	Automotive rack and pinion.	√	√
Tires	18.5" x 8" DOT rated tires on steel wheels 175/50 R13 (7x20x13) DOT rated radial tires on chrome wheels	√	√
Frame	Mig-welded tubular steel, electrostatic powder coated Lifted profile chassis (5.5" ground clearance)	√ -	√ √
Rated Capacity	Total number of occupants Cargo not to exceed ___ lbs, including driver	2/4 750	2/4 750
For a full list of dimensions and capacities, refer to the vehicle's Owner's Manual.			

**CONTROLS AND OPERATION**

**Location of Controls**

Figure 2-3 shows the location of the vehicle's controls.

**Operation**

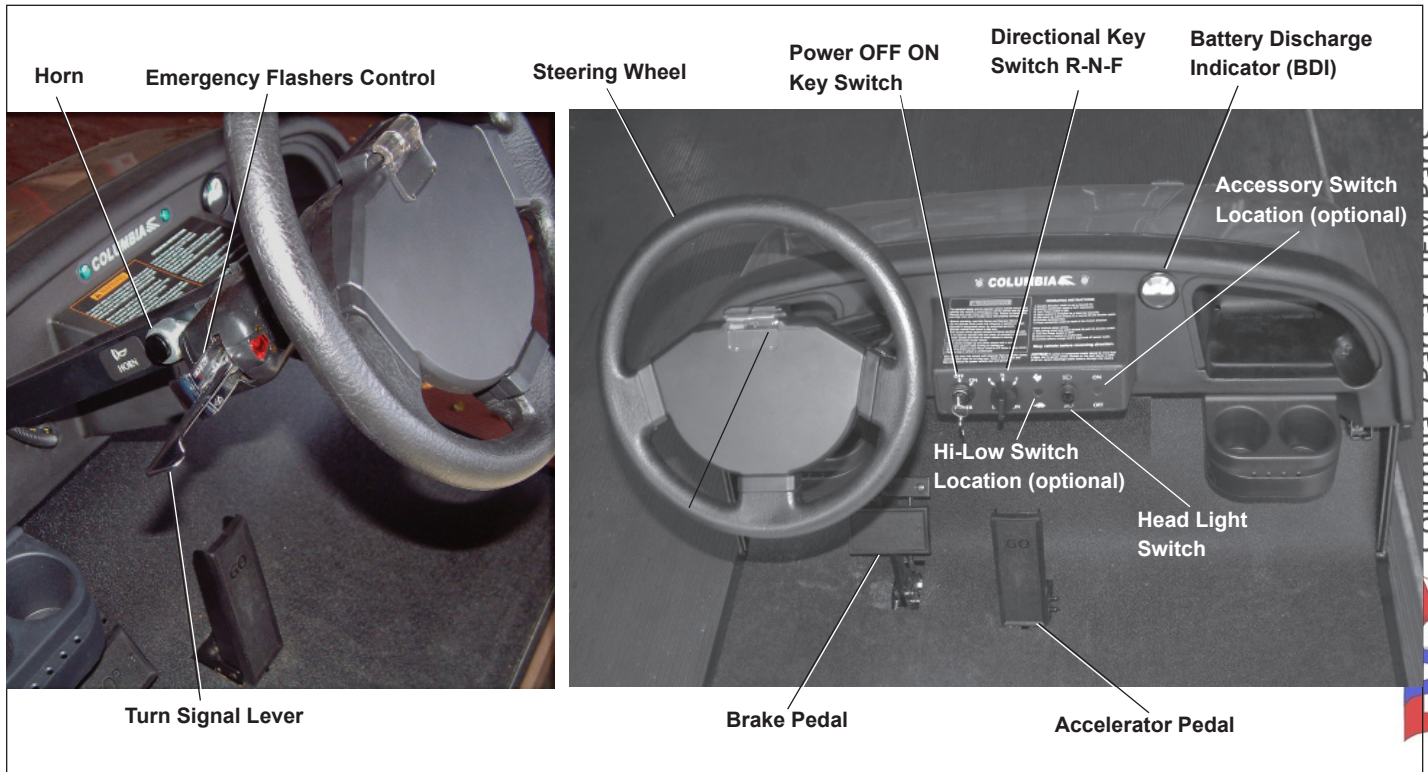
**NOTICE**

Controls should operate smoothly and easily without sticking or requiring undue effort.

1. Set the power key switch to the ON position.
3. Set the directional key switch to the desired direction of travel (F=Forward, R=Reverse).

**▲ WARNING**

Be sure safety directional key switch is in desired direction of travel before depressing accelerator.



**Figure 2-3. Controls**

Columbia / ParCar OEM Parts  
 evtechnicalservices.com  
 TECHNICAL SERVICES

**PRE-OPERATION INSPECTIONS**

**▲ WARNING**

Each vehicle has been inspected and adjusted to factory specifications before delivery. Upon receipt of vehicle, perform a pre-delivery inspection of the vehicle. Also, before using the vehicle, there are checks that must be performed to ensure that it is in safe working order.

**Only trained maintenance professionals should service or repair this vehicle. Persons doing even simple repairs or service should have a working knowledge and experience in general electrical and mechanical repair. Follow all procedures and observe all warnings stated in this manual. Use caution and common sense.**

**PRE-OPERATION CHECK LIST**

Service Item	Service Method/Check	Reference
Vehicle Body	Visually, check for damaged or loose hardware.	See section 8.
Steering and Linkages	Test drive, check for free movement and proper operation.	See section 6.
Accelerator/Brake Operation	Test drive, check free travel and braking action.	Refer to Owner's Manual index for specifications.
Warning Labels	Visually inspect all labels for readability or missing.	Verify labels are in place and readable.
Tires	Visually check for wear or damage. Verify proper tire inflation.	Refer to Owner's Manual index for specifications.
Reverse Warning Buzzer or In- Motion Beeper	Test drive, check for proper operation.	Verify an audible sound heard.
Charger Plug and Receptacle	Check for damage and snug fit.	Refer to Owner's Manual index for
Head, Tail or Flasher, Lights	Check for proper operation	Verify lights and flashers work.
Batteries	Check Battery Discharge Indicator indicator (BDI) for battery condition.	Refer to Owner's Manual index for specifications.
Horn	Check for proper operation.	See section 8.

Columbia / ParCar OEM Parts  
evtechnicalservices.com





This page intentionally left blank.

**PERIODIC MAINTENANCE.....3-2**

**BATTERIES .....3-5**

**CHASSIS LUBRICATION .....3-5**

    Wheel Hubs .....3-5

    Brake Pedal .....3-5

**REAR AXLE.....3-5**

**CHASSIS CLEANING.....3-5**

**SEAT CLEANING .....3-5**

**LIFTING INSTRUCTIONS.....3-6**

    Tools Required.....3-6

    Hoist Lifts .....3-6

    Floor Jack Procedure .....3-6

    Jack Stands.....3-6

**VEHICLE STORAGE .....3-7**

**RETURNING VEHICLE TO SERVICE.....3-7**

**TOWING THE VEHICLE.....3-7**

**TRANSPORTING THE VEHICLE.....3-7**

**TORQUES AND METRIC CONVERSION FACTORS .....3-8**




**ELECTRIC VEHICLE SERVICE**

When servicing the electric vehicle always observe the following:

**! SAFETY FIRST !**

**Always turn Power key to OFF, Directional key switch to Neutral, remove Power key, block tires and disconnect the battery negative (-) cable before performing any vehicle service to avoid accidental startup of vehicle and possible personal injury.**

**PERIODIC MAINTENANCE**

A comprehensive maintenance program is important for the safe, reliable operation of all Columbia ParCar vehicles. The recommended procedures described in this service manual are effective methods for performing periodic maintenance and repair.

The maintenance procedures outlined in this manual are recommended when servicing the vehicle. Refer to maintenance checklist for frequency of service. Perform only those maintenance instructions described in this manual. If major repairs are needed, contact the local Columbia Dealer for assistance. Columbia Dealers have the technical experience, training and original Columbia Vehicle parts for the vehicle. Always use original Columbia Vehicle parts when servicing the vehicle.

**NOTICE**

Some procedures require the use of special tools. These special tools must be used when and where recommended.

**NOTICE**

When performing Monthly, Quarterly, Semi-Annual or Annual maintenance, ensure that Daily and Weekly inspections are included.

**NOTICE**

The environment that the vehicle operates in can vary widely. Severe service operations will require the periodic maintenance recommendations to be adjusted to shorter time intervals. The following calendar is one example of how scheduling routine maintenance can be managed.

PERIODIC SERVICE CALENDAR		
<b>JANUAR Y</b> Monthly	<b>FEBRUARY</b> Monthly	<b>MARCH</b> Quarterly
<b>APRIL MA</b> Monthly	<b>Y</b> Monthly	<b>JUNE</b> Semi-Annual
<b>JULY AUGUST</b> Monthly	Monthly	<b>SEPTEMBER</b> Quarterly
<b>OCTOBER NOVEMBER</b> Monthly	Monthly	<b>DECEMBER</b> Annual

**NOTICE**

Daily maintenance is performed daily before operation of vehicle by owner or operator. Weekly maintenance is performed on a weekly basis to include all daily maintenances and is performed by the owner, operator or trained maintenance personnel.

Columbia / ParCar OEM Parts  
evtechnicalservices.com  


MAINTENANCE SCHEDULE CHECKLIST - BODY/FRAME/CHASSIS							
Component Procedure		Daily*	Weekly	Monthly†	Quarterly† (25 hours)	Semi-Annual† (50 hours)	Annual† (100 hours)
Body, Seat & Frame	Visually inspect for damage or tears	x					
Hardware	Tighten as needed		x				
Vehicle and undercarriage	Wash as needed		x				
Clean Body and Seat	Wash as needed		x				
Lubricate chassis	Lubricate body hinges					x	
Lubricate front suspension/steering	Lubricate				x		
Warning and operating labels	Ensure labels in place and readable	x					
Windshield tightness	Check for visibility and check fasteners for	x					

\* Service done by Owner † Service done by trained maintenance personnel

MAINTENANCE SCHEDULE CHECKLIST - OPERATING CONTROLS							
Component Procedure		Daily*	Weekly	Monthly†	Quarterly† (25 hours)	Semi-Annual† (50 hours)	Annual† (100 hours)
Steering & Linkages movement	Check for free	x					
Accelerator Linkage adjustment	Check for free movement and return	x					
	Check micro switch						x
Brakes	latching	x					
	Check parking brake release	x					
	Check brake cables damage			x			
	Clean and adjust brakes						x
	Check rear brake drum/ axle nut torque (6.5 ft lbs)						x
	Apply one shot of grease to pedal grease fitting						x
Directional Keyswitch operation	Check for smooth Forward & Reverse	x					
Light Switch	Check for operation	x					
Turn Signal & Emergency Flashers	Check for operation	x					

\* Service done by Owner † Service done by trained maintenance personnel

Columbia / ParCar OEM Parts  
evtechnicalservices.com

MAINTENANCE SCHEDULE CHECKLIST - ELECTRICAL							
Component	Procedure	Daily*	Weekly	Monthly†	Quarterly† (25 hours)	Semi-Annual† (50 hours)	Annual† (100 hours)
Batteries battery T	Check charge (fill cells prior to charging)	x					
	Check electrolyte level		x				
	Clean terminals and wash case		x				
	Test batteries					x	
Electrical wires	Check for tightness or damage		x				
Reverse warning keyswitch) buzzer	Check for operation (use	x					
* Service done by Owner							
† Service done by trained maintenance personnel							

MAINTENANCE SCHEDULE CHECKLIST - TIRES & WHEELS							
Component	Procedure	Daily*	Weekly	Monthly†	Quarterly† (25 hours)	Semi-Annual† (50 hours)	Annual† (100 hours)
Tires damaged	Check for wear and	x					
	Check tire pressure	x					
	Check for dented or rims			x			
Front wheel alignment	Check & adjust as necessary (section 6)					x	
Lug nuts	Check for tightness	x					
Steering linkage of	Check for excessive tightness hardware			x			
Front wheel hub grease fitting	Apply one shot of grease to each hub fitting						x
* Service done by Owner							
† Service done by trained maintenance personnel							

Columbia / ParCar OEM Parts  
evtechnicalservices.com  


MAINTENANCE SCHEDULE CHECKLIST - ELECTRIC MOTOR							
Component	Procedure	Daily*	Weekly	Monthly†	Quarterly† (25 hours)	Semi-Annual† (50 hours)	Annual† (100 hours)
Operation	Test drive for operation	x					
Inspect brush Brushes and carbon	motor length remove dust						x

\* Service done by Owner  
† Service done by trained maintenance personnel

MAINTENANCE SCHEDULE CHECKLIST - FLUIDS							
Component	Procedure	Daily*	Weekly	Monthly†	Quarterly† (25 hours)	Semi-Annual† (50 hours)	Annual† (100 hours)
Differential	lubricant	Check level				x	x

\* Service done by Owner  
† Service done by trained maintenance personnel

**BATTERIES**

Batteries may be recharged if vehicle has been driven 15 minutes or more since the previous charge. Before charging, be sure master power key switch is Off and key is removed from the switch. Refer to *Chapter 9* for all procedures relating to the batteries.

**CHASSIS LUBRICATION**

**Wheel Hubs**

The vehicle has 2 grease fittings, one in each wheel hub. These fittings should get one pump of grease annually. See *Section 6 - Front Wheels and Hubs*.

**Brake Pedal**

The brake pedal assembly has one fitting located under the vehicle. Apply one pump of grease annually. See *Section 5 - Accelerator and Brake System*.

**REAR AXLE**

Check the rear axle oil only if signs of leakage are detected. Change oil at 24 months or 1250 mile (2000 km) intervals, whichever occurs first. Refer to *Section 7*. Capacity - 12 ounces (360 ml). Light weight gear lubricant SAE #30 oil.

**CHASSIS CLEANING**

Proper cleaning materials and techniques are vital to the care of the vehicle. Wash underside of vehicle to remove all dirt and debris. Wash chassis and body with a mild detergent only. Do not use abrasives on the paint.

**CAUTION**

Do not direct high pressure water at the controller, speed switch, or top of batteries. Dry the controller and top surfaces of the batteries immediately after washing.

**SEAT CLEANING**

Proper cleaning will extend the life of the vehicle seat. Use mild soap or detergent and a soft sponge to clean whenever necessary. For stubborn or imbedded dirt, a soft bristle brush may be used.

**NOTICE**

Do not use harsh chemicals or abrasives to clean seat material. Cracking, splitting, or "melting" of seat materials may occur. If seat material becomes torn or split, it should be replaced.

Columbia ParCar OEM Parts  
evtechnicalservices.com

**LIFTING INSTRUCTIONS**

**▲WARNING**

Use extreme caution lifting or working around lifted vehicle. Vehicle should be lifted only when parked on a flat, hard and level surface.

Do not work under the vehicle unless it is firmly supported on jack stands.

When lifting the vehicle for service, use a sturdy lifting device such as a floor jack or hydraulic lift. Always, wedge wheels and set parking brake of the vehicle to keep it from rolling. When using a lifting device, lift only on sturdy parts under the vehicle, an example being the frame. When using a floor jack, lift only on sturdy parts under the vehicle, an example being the frame or axle housing. Place jack stands or support blocks under vehicle frame to support vehicle weight for added safety. Watch for cables, linkages or wire harness.

**▲CAUTION**

If any vehicle is raised while loaded, check that the load is secured before lifting vehicle. Failure to do so could cause damage to load, vehicle, or personal injury.

Before lifting, always chock tires. Use care to prevent tipping or rolling over.

Be careful not to damage the brake cables during lifting operation.

**Tools Required**

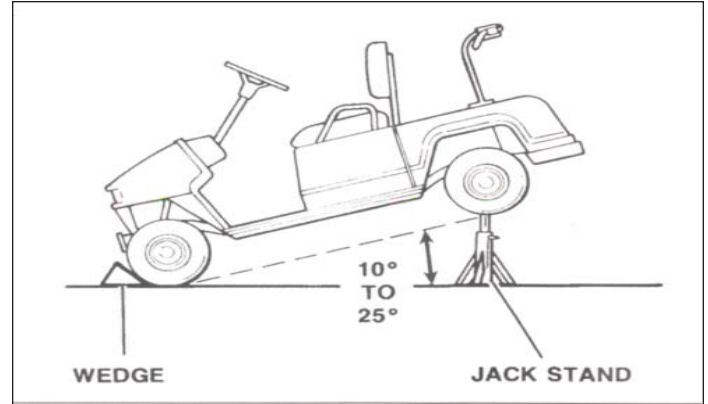
- hydraulic trolley jack
- chocks or wooden blocks
- jack stands or support blocks

**Hoist Lifts**

If a hoist is used to lift the vehicle, check that the hoist is rated at a capacity greater than the vehicle weight. Lift the vehicle sufficiently from the floor, 10° to 25° angle, to allow the placement of jack stands to support the weight of the vehicle during service. See Figure 3-1.

**HOISTING THE REAR OF VEHICLE**

1. To lift the rear, connect the lifting eyes/hooks to rear frame tubes at right and left sides. DO NOT use the bumper for lifting. Hoist vehicle sufficiently to place jack stands underneath frame.
2. Place jack stands under frame at right and left sides to allow access under the vehicle.
3. When work is completed, lift the vehicle and remove the jack stands, then lower vehicle to the floor.



**Figure 3-1. Lifting Recommendations**

**HOISTING THE FRONT OF VEHICLE**

1. To lift the front, connect the lifting eye/hooks to front frame tubes at right and left sides. Do not use the bumper for lifting.
2. Place jack stands under frame at right and left sides to allow access under vehicle.
3. When work is completed, lift the vehicle and remove the jack stands, then lower vehicle to the floor.

**Floor Jack Procedure**

If a floor jack is used to lift the vehicle, check that the floor jack is rated at a capacity greater than the vehicle weight. Lift the vehicle sufficiently from the floor to allow the placement of jack stands or wooden blocks and hold the weight of the vehicle during service.

**LIFTING THE REAR OF VEHICLE**

1. To lift the rear, place floor jack under the rear axle housing. Do not use the bumper for lifting. Raise vehicle sufficiently to place jack stands underneath frame.
2. Place jack stands under frame at right and left sides to allow access under the vehicle.
3. When work is completed, place floor jack under rear axle housing, lift the vehicle and remove the jack stands, then lower vehicle to the floor.

**LIFTING THE FRONT OF VEHICLE**

1. To lift the front, place floor jack under the heavy leaf spring retainer plate. Do not use the bumper for lifting. Raise vehicle sufficiently to place jack stands underneath frame.
2. Place jack stands under frame at right and left sides to allow access under the vehicle.
3. When work is completed, place floor jack under leaf spring retainer plate, lift the vehicle and remove the jack stands, then lower vehicle to the floor.

**Jack Stands**

Jack stands need to be of sufficient rated load capacity to hold the vehicle safely. See Section 2 - Vehicle Specification Chart for empty vehicle weight.

Columbia/ParCar OEM Parts  
evtechnicalservices.com





**VEHICLE STORAGE**

**▲ WARNING**

Turn Power key switch OFF. Remove Power key during storage to prevent unintentional starting of vehicle.

**▲ WARNING**

Do not attempt to charge a battery that is frozen or if battery case is excessively bulged. Properly dispose of battery. Frozen batteries can explode.

Electric vehicles stored over 6 to 8 weeks must be protected to maintain battery life. Several guidelines should be observed when storing the electric vehicle.

1. Charge batteries fully. With electrolyte full in all cells, store batteries in as cool place as possible. If stored above 50°F (10°C), check state of charge every 4 to 6 weeks and charge as necessary to maintain 1.250 to 1.270 specific gravity. If vehicles are stored in temperatures below 40°F (4°C) check state of charge every 15 to 18 weeks. Use table below to determine freezing point of battery and maximum recommended storage temperature. Refer to *Section 9 - Batteries* in this manual for a charging procedure. Remove battery pack negative cable.
2. Wash off any corrosion around the terminals with a solution of baking soda and water. Do not allow this solution to enter batteries.
3. Store vehicle in a cool dry place to prevent battery discharge.
4. Maintain tire pressure at 35 psi during storage for 18.5 x 8 tires and 50 psi for 175/50 R13 tires
5. Grease steering hubs and continue quarterly lubrication during storage period. Refer to periodic maintenance in the beginning of this section.
6. Clean vehicle body, seat, battery compartment and vehicle underside.
7. Do not engage parking brake. Block wheels to prevent movement.
8. Periodically charge battery during storage to prevent damage to battery. See step 1.

**Specific Gravity and Freeze Point**

Specific Gravity	1.250	1.225	1.200	1.117	1.110
Freezing Point of Electrolyte	F C -65° -54	F C -39° -39	F C -18° -28°	F C -2° -19°	F C +17° -8°

**RETURNING VEHICLE TO SERVICE**

1. Reconnect battery negative (-) terminal.
2. Charge batteries fully.
3. Check tire pressure and readjust if necessary.
4. Perform initial maintenance per *Periodic Maintenance* in the beginning of this section.

**TOWING THE VEHICLE**

**▲ CAUTION**

Use only straps, chains or towing devices that are rated to handle the full weight capacity of the vehicle in tow.

**▲ CAUTION**

Use caution and common sense while towing disabled vehicles.

- Use a tow chain, strap or towing device rated to handle the full weight of the vehicle in tow.
- Use a tow chain, strap or towing device long enough to provide a safe distance between vehicles.
- Connect the selected towing device to the front tubular frame undercarriage.
- Connect the towing device to the towing vehicle frame.
- Turn Power key to the Off position. Remove key.
- Release the brake.
- Do not exceed 5 MPH (8 KPH) while towing.
- Allow ONLY one person in the towed vehicle to steer and apply additional braking, as necessary.
- Tow only one vehicle at a time.
- Avoid sudden stops, sudden starts and sharp turns while towing.

**TRANSPORTING THE VEHICLE**

**▲ WARNING**

Remove power key from vehicle.

**▲ CAUTION**

Never tow a vehicle behind an auto or truck unless on an approved trailer.

When transporting (trailer) the vehicle over long distances or on the highway observe the following:

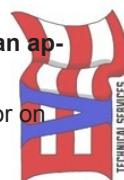
- Use trailers specifically designed to carry the Columbia ParCar vehicle that meets all federal, state and local requirements.
- Secure vehicle to the trailer following trailer manufacturer's instruction.

**▲ CAUTION**

Increased transporting speed adds undue stress to windshield, cab or sun top and will increase chance of loss, damage accident or injury.

Use care when transporting on windy days. Example: A 60 MPH speed into a 40 MPH head wind is equal to traveling at 100 MPH. Industrial vehicles are not rated to withstand this level of stress and parts could be blown from top or cab, causing accident or injury.

Columbia / ParCar OEM Parts  
evtechnicalservices.com





**TORQUES AND METRIC CONVERSION FACTORS**

Individual component torques and metric equivalents are listed where the maintenance is to be performed throughout this manual. When a specific fastener torque is not specified, use the

following Torque Table as a general guide in determining proper torque. When a metric equivalent is not listed, use the Conversion Factors Chart to convert to metric values.

Torque Table													
Torque to the value in this table unless specified otherwise.													
Fine or coarse thread fastener	Grade Designation	Tensile Strength Minimum	Material	Screw, Stud or bolt shank size or diameter									
				Torque figures are in ft. lbs.									
				1/4	5/16	3/8	7/16	1/2	9/16	5/8	3/4	7/8	1
cap screw	S.A.E. 2 A.S.T.M. A-307 steel	64,000 psi	low carbon steel	6	11	19	30	45	66	90	150	202	300
cap screw	S.A.E. 3 steel	100,000 psi	medium carbon steel	9	17	30	47	69	103	145	234	372	551
cap screw	S.A.E. 5 A.S.T.M. A-499 steel	105,000 psi	medium carbon steel or low alloy heat treated	9	18	31	50	75	110	150	250	378	583
cap screw	A.S.T.M A-354BB steel			9	18	31	50	75	110	150	250	378	583
cap screw	A.S.T.M A-325							100		200	355	525	790
cap screw	A.S.T.M A-354-BC steel	125,000 psi	low alloy or med. carbon steel quenched tempered	11	20	34	54	81	119	167	269	427	611
cap screw	S.A.E. 6 steel	133,000 psi	med. carbon steel quenched tempered										
cap screw	S.A.E. 7 steel		med. carbon alloy quenched tempered roll threaded	12.5	24	43	69	106	150	209	350	550	825
cap screw	S.A.E. 8 steel	150,000 psi	med. carbon alloy quenched tempered	13	28	46	75	115	165	225	370	591	893

Columbia / ParCar OEM Parts  
evtechnicalservices.com



<b>Conversion Factors Chart</b>					
Into Metric			Out of Metric		
to convert from	To	Multiply by	to convert from	To	Multiply by
<b>Work force measurements</b>					
inch-pound	N. m.	0.1130	Newton-meter	in. lb.	8.8496
foot-pound	N. m.	0.3558	Newton-meter	in. lb.	0.7376
<b>Length Measurements</b>					
inch	mm	25.4	micrometer	in.	0.394
foot	m	0.3048	meter	ft.	3.2808
miles	kilometers	1.6	kilometers	miles	0.62
<b>Liquid Volume Measurements</b>					
fluid ounces	milliliters	30	millimeters	fluid ounces	0.03
pints	liters	0.47	liters	pints	2.1
quarts	liters	0.95	liters	quarts	1.06
gallons	liters	3.8	liters	gallons	0.26
<b>Temperature</b>					
Fahrenheit	°C	°C = (°F-32/1.8)	Celsius	°F	°F = 1.8°C + 32

Columbia / ParCar OEM Parts  
evtechnicalservices.com



**This page intentionally left blank.**

**PRE-TROUBLESHOOTING STEPS.....4-2**  
**BATTERY TESTING .....4-3**  
**TROUBLESHOOTING SPECIFIC COMPLAINTS.....4-4**  
**ACEplus SEVCON CONTROLLER POWER SYSTEM.....4-8**  
**Smartdrive SEVCON CONTROLLER POWER SYSTEM .....4-12**  
**SPEED SWITCH (POT BOX) TESTING .....4-14**  
**COMPONENT TROUBLESHOOTING.....4-14**

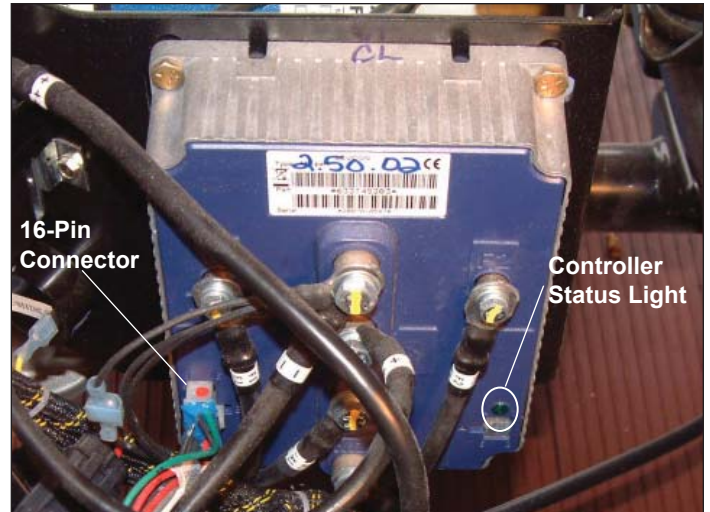


**ELECTRIC VEHICLE SERVICE**

When servicing your electric vehicle always observe the following:

**! SAFETY FIRST !**

**Always turn Power key to OFF, Directional key switch to Neutral, remove Power key, block tires and disconnect the battery negative (-) cable before performing any vehicle service to avoid accidental startup of vehicle and possible personal injury.**



*Figure 4-1. Motor Controller Status Light & Pin Connector*

**PRE-TROUBLESHOOTING STEPS**

Before troubleshooting a vehicle for any problem or symptoms, certain steps must be followed.

Inspect/Test	Corrective Action
1. Ensure the vehicle is safe for service.	Visually inspect for any obvious signs of hazards such as sharp edges in the body or other parts, open wire insulation or wire connections, or discolored parts of the vehicle indicating heat or chemical presence.
2. Record the VIN (Vehicle Identification Number) or serial number.	This number is necessary to obtain technical help or support, submit warranty, and is essential in order to understand completely the vehicle that is being serviced.  The VIN, with the help of the correct VIN matrix, will denote specific information about each vehicle, such as operating power system and voltage, brake package options, speed operation settings, and other vehicle configuration options.

**BATTERY TESTING**

The first step in servicing any electric vehicle that is not operating properly is to completely test the batteries. The batteries are the source of power for the vehicle drive and auxiliary systems, therefore are the most integral part of the electric vehicle troubleshooting. Battery testing should be done as follows and in the order as follows

Inspect/TestCondition		Corrective Action
<p>1. Perform a visual examination of batteries and connections.</p>	<p>Examine for signs of corrosion and clean/or replace any affected terminals or cables.</p>	<p>The batteries can be cleaned by hose washing with a standard garden hose or with a soft bristle brush (ensure battery caps are present and tight before washing batteries).</p> <p>The batteries can be cleaned by hose washing with a standard garden hose or with a soft bristle brush (ensure battery caps are present and tight before washing batteries).</p>
	<p>Examine the battery hold-down. If the material from the hold-down has been dissolved by the sulfuric acid in the batteries, the hold-down can act as a drain on the battery pack.</p>	<p>Replace the hold-down if it appears damaged.</p>
<p>2. Test each battery with a VOM (volt-ohm meter).</p>	<p>With VOM set to a scale able to read DC volts at up to 100 volts (or greater), check each battery individually, and test the entire pack together.</p>	<p>Place the VOM probes on the battery positive post and battery negative post of each battery. Write down the reading from each battery. Each battery should contain at least 6.0 volts and no battery should be more than .5 volts lower than the highest reading. If any battery tests low on charge, change the battery individually with the auxiliary charger or the entire pack with the onboard charger (allow vehicle to charge until the green charger light is illuminated, indicating full charge). See Figure 1. If one or more batteries still test low, the battery should be tested individually and replaced as necessary.</p> <p><i>NOTE: It is recommended that all batteries in a system be changed together to ensure the batteries are the same brand, vintage, and service life.</i></p>
<p>3. Test each battery cell with a battery hydrometer.</p>	<p>Any battery or battery cell that tests low should be fully charged and then rechecked.</p>	<p>If the cell continues to test low with a hydrometer, the battery should be replaced. See note above.</p>
<p>4. A battery may test good with a voltage or hydrometer test when no load is being drawn from it. Test using a battery load tester.</p>	<p>A battery must be able to produce 45 minutes of capacity when tested at 55 amp draw after a complete recharge cycle.</p>	<p>A battery that is not able to produce this capacity should be replaced. See note above.</p>

Columbia / ParCar OEM Parts  
 evtechnicalservices.com  




**TROUBLESHOOTING SPECIFIC COMPLAINTS**

The first step in servicing any electric vehicle that is not operating Troubleshooting is a matter of investigation and deduction based on the symptoms and the possible causes. Recording every possible solution to every possible cause would be impossible, but this troubleshooting section is designed to assist in solving issues that may arise in the service life of an electric vehicle.

The main key problems encountered with the vehicle(s) are:

- Vehicle will not move; forward or reverse
- Vehicle operates slowly
- Vehicle drives in forward or reverse only
- Vehicle drives but operation is jerky or inconsistent
- Vehicle power cuts out

**IMPORTANT: Always follow troubleshooting guide in exact sequence as listed. Performing tests out of sequence will cause inaccurate results and lost time in diagnosing electri-**

**Vehicle Will Not Move; Forward or Reverse**

Before attempting to service a vehicle, complete the pre-service inspection and fully test the batteries as described on the previous page. Set the vehicle power switch to "ON". The green status light (Figure 4-1) on the controller will show one of three conditions; steady off, steady on, or flashing.

*NOTE: In some lighting situations it is difficult to determine the condition of the fault light. Ensure an accurate reading of the light by shading it.*

Fault Code	Condition	Corrective Action
Fault code light steady OFF	The controller is not getting the proper voltage or the controller has failed internally.	<ol style="list-style-type: none"> <li>1. Check to make sure the controller has a good battery negative connection at the B- terminal. Attach the black lead of the VOM to the B- terminal and attach the red lead to the battery pack positive post.  On DC volts scale, full battery pack voltage should be observed. If not, check or replace the connections and cable between the main battery pack negative post and the controller B- post. If correct voltage is present, disconnect the 16 pin wire connection from the controller. Set main power switch to ON. Insert the black lead to the B- terminal on the controller and the red lead to the red #1 wire of the 16 pin connector. Full voltage should be observed.</li> <li>2. If voltage is present, reconnect the 16 pin plug connector to the controller and ensure the wires are fully seated in the back of the plug. If there is system voltage between B- post and the #1 pin, and the controller light does not illuminate, the controller has failed internally and must be replaced.</li> <li>3. If there is no voltage present between the #1 pin and the B- terminal, and B- terminal has a good connection to battery pack negative, the red #1 wire circuit is not energizing properly. Make the charger positive (red) wire is connected to the main battery pack positive terminal, then check the table below.</li> </ol>

Columbia / ParCar OEM Parts  
evtechnicalservices.com  
TECHNICAL SERVICES

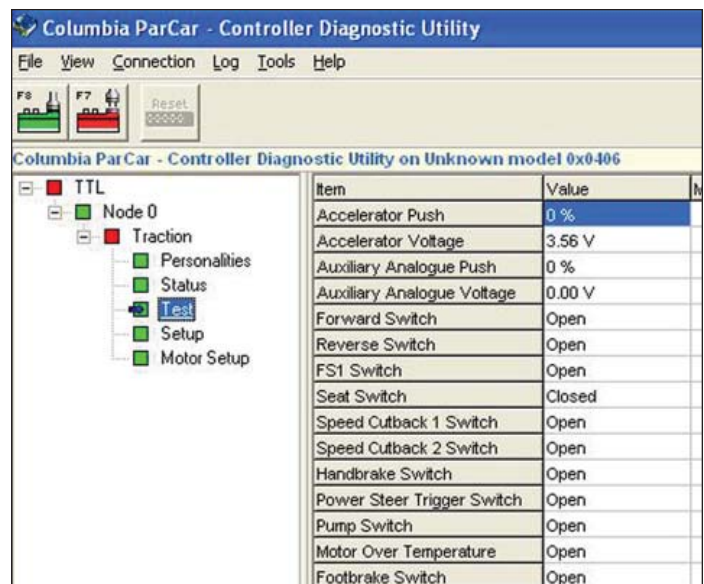
VOM Black Lead	VOM Red Lead	Pass	Fail	Correction Action - Check
Main battery negative post	Green charger interlock wire	Full system voltage	Low or no voltage	Charger red lead to battery positive connection. Charger output wires for damage
Main battery negative post	Red wire #15 side of 1 amp fuse connector	Full system voltage	Low or no voltage	Red wire #15 connection to green charger interlock wire Red wire #15 for damage
Main battery negative post	Red wire #16 side of 1 amp fuse connector	Full system voltage	Low or no voltage	1 amp fuse or fuse connections
Main battery negative post	Red wire #28 at power key switch	Full system voltage	Low or no voltage	Red wire #18 for damage Red wire #28 to red wire #16 connection (at optional low/run connection)
Main battery negative post	Red wire #17 at solenoid positive tab	Full system voltage	Low or no voltage	Wiring from power key switch for damage/poor connections
Main battery negative post	Red wire #1 at 16 pin connector	Full system voltage	Low or no voltage	Wiring from power key switch for damage/poor connections

Vehicle Will Not Move; Forward or Reverse (continued)		
Fault Code	Condition	Corrective Action
Fault code light steady ON	Indicates the controller is powered up and ready to perform. If the vehicle fails to operate with the fault code light in the steady on condition, it is likely the controller is not receiving the correct input from the drive system, or a mechanical fault has occurred.	<ol style="list-style-type: none"> <li>1. Check to make sure the parking brake is releasing and the vehicle will not roll when pushed on a level surface.</li> <li>2. Check for other mechanical failures such as stripped hubs or anything that would prevent the vehicle from being able to operate. Make sure a direction of travel is selected (the vehicle will not attempt to drive while set to Neutral).</li> </ol> <p>Check the inputs of the electrical system by using the Computer Diagnostics Utilities (Columbia Part No. 30001-04) or the handheld calibrator (Columbia Part No. 30003-04) . See the following procedures.</p>

**TROUBLESHOOTING WITH PCPAK**

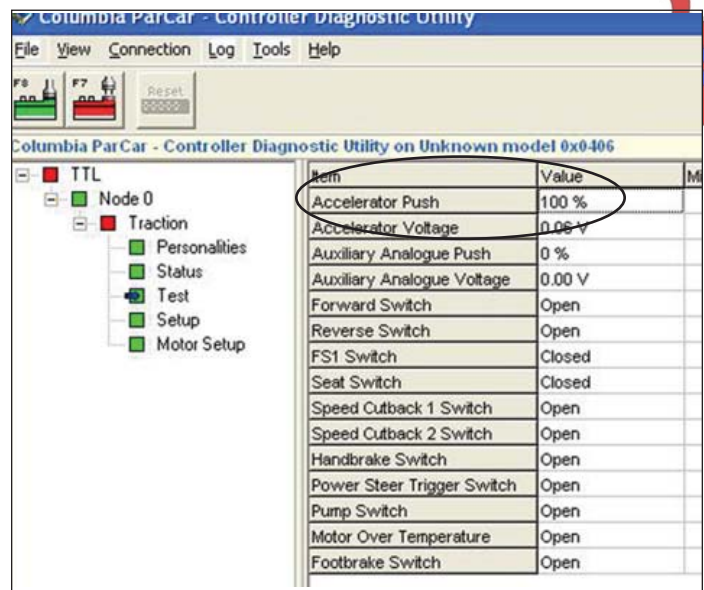
With the vehicle power system off, connect the PCPak (computer diagnostic utility) and then turn the vehicle power on.

1. Open the connection between the controller and the PCPak utility. On the left side of the screen, select the “test” section under the “traction” pull down. This screen will display the inputs the controller is observing at that time (Figure 4-2).



**Figure 4-2. Basic Test Inputs**

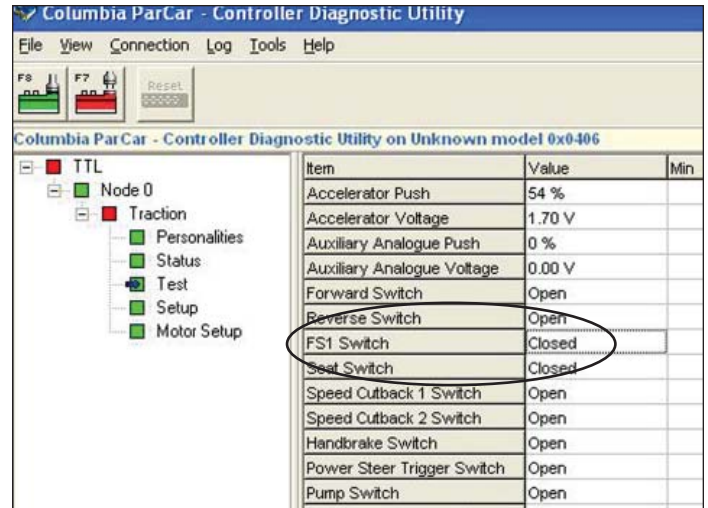
2. With the Forward / Reverse switch set to Neutral, slowly press the accelerator pedal. The “Accelerator Push” value should rise in value from 0-100% smoothly as you press the pedal (Figure 4-3). If the value does not change, the controller is not receiving input from the accelerator control device (potentiometer or linear accelerator device). Check all cable and wire connections regarding the accelerator control device. If the value does rise, but not to 100%, adjust the accelerator cable that attaches to the accelerator device.



**Figure 4-3. Accelerator Push Test**

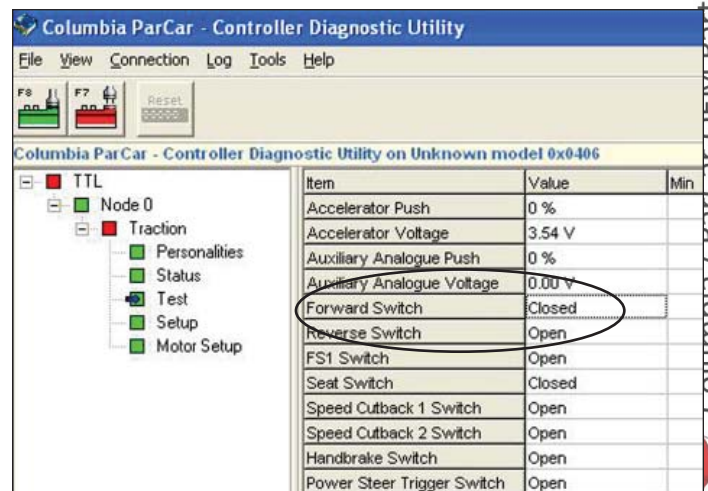
**TROUBLESHOOTING WITH PCPAK (continued)**

3. Check the FS1 Switch input on the same screen. With the accelerator at rest, the value for the FS1 Switch should read “open”. When the accelerator pedal is pressed, the value should change to “closed” (Figure 4-4). If the value fails to close, check the FS1 wiring circuit and test the switch with a VOM. Check the wiring back to the controller (Pin 4).



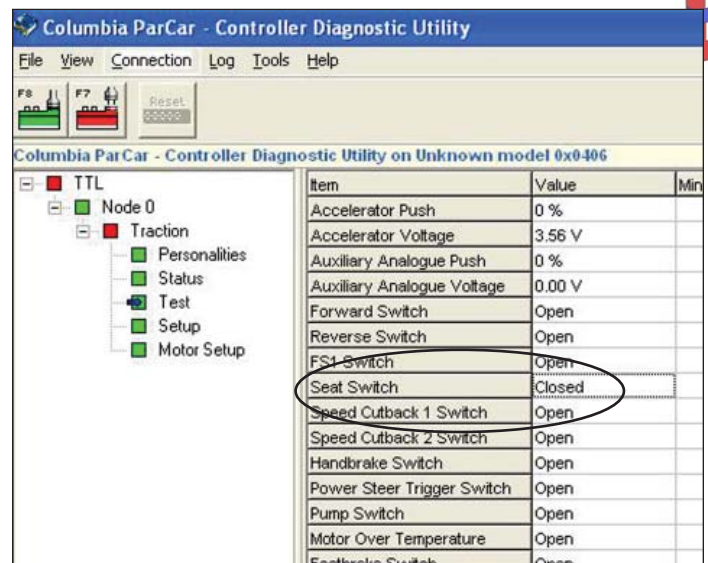
**Figure 4-4. FS1 Switch Test**

4. Check the direction input to the controller. Observe the value of the “Forward Switch” item while turning the direction selection switch to “Forward” and to “Neutral”. The switch should read “open” when the switch is in neutral and “closed” when in forward (Figure 4-5). Do the same in reverse by monitoring the “Reverse Switch” item and value. If the switch fails to close in either direction, check the switch with a VOM and the wiring back to the controller (Pin 2 for Forward and Pin 3 for Reverse).



**Figure 4-5. Forward Switch Test**

5. Check the “Seat Switch” item and value (Figure 4-6). For vehicles equipped with a seat switch, the value should read “open” when the operator seat is not occupied, and “closed” when the operator seat is occupied. If the switch fails to close, check the wiring from the B- post of the controller to the seat switch, test the seat switch with a VOM, and check the wiring back to the controller (pin 5). For vehicles without a seat switch, the value should read “Closed”. If the switch does not register as closed, check the black 5 wiring from the B- post of the controller to controller plug (pin 5).



**Figure 4-6. Seat Switch Test**

If the vehicle is receiving the correct inputs and fails to operate, contact Columbia tech support for further assistance.

Columbia / ParCar OEM Parts  
evtechnicalservices.com



**TROUBLESHOOTING WITH THE HANDHELD CALIBRATOR**

1. Connect the handheld calibrator to the vehicle and enter the "Read-Only" mode (RON). Scroll down by pressing "Select" button until you reach the "19" menu (location 19.01). The "Test" light on the left side of the calibrator will illuminate when the "19" menu is selected. This menu shows the inputs the controller is observing at that time. At 19.01, the calibrator displays the "Accelerator Push" in percentage.  
  
2. With the Forward / Reverse switch set to Neutral, slowly press the accelerator pedal. The "Accelerator Push" value should rise in value from 0-100% smoothly as you press the pedal. If the value does not change, the controller is not receiving input from the accelerator control device (potentiometer or linear accelerator device).  
  
Check all cable and wire connections regarding the accelerator control device. If the value does rise, but not to 100%, adjust the accelerator cable attached to the accelerator device.
3. Next, check the FS1 Switch input by scrolling to the 19.07 location. At rest, the value for the FS1 Switch should read open, or (3.OP). When the accelerator pedal is pressed, the value should change to closed, or (3.CL). If the value fails to close,

4. check the FS1 wiring circuit and test the switch with a VOM. Check the wiring back to the controller (Pin 4).
4. Check the direction input to the controller. Observe the value of the "Forward Switch" item at location 19.05 while turning the direction selection switch to "Forward" and to "Neutral". The switch should read open (1.OP) when the switch is in neutral and closed (1.CL) when in forward. Do the same in reverse by monitoring the Reverse Switch at location 19.06 and value. If the switch fails to close in either direction, check the switch with a VOM and the wiring back to the controller (Pin 2 for Forward and Pin 3 for Reverse).
5. Check the Seat Switch at location 19.09. For vehicles equipped with a seat switch, the value should read open (5.OP) when the operator seat is not occupied, and closed (5.CL) when the operator seat is occupied. If the switch fails to close, check the wiring from the B- post of the controller to the seat switch, test the seat switch with a VOM, and check the wiring back to the controller (pin 5). For vehicles without a seat switch, the value should read closed (5.CL). If the switch does not register as closed, check the black wire #5 wiring from the B- post of the controller to controller plug (pin 5).

If the vehicle is receiving the correct inputs and fails to operate, contact Columbia tech support for further assistance.

**VEHICLE WILL NOT MOVE; FORWARD OR REVERSE - LED DIAGNOSTIC GUIDE**

Green LED Flashes	Check/Test
1 Flash	Check all wire connections for good connection and free of corrosion. Call Columbia Technical Support if problem persists.
2 Flash	Perform steps 1 - 5 under <i>Troubleshooting with Handheld Calibrator</i> above.
3 Flash	Check all wire connections. Disconnect all electrical accessories (strobe lights, heaters, etc.) External or internal wiring faults will cause controller 3 Flash. Eliminate all "non-controller" sources first. Plug in calibrator and read location 13.10 fault code for more precise fault cause(s). Call Columbia Technical Support if problem persists.
4 Flash	Bench test 24 volt main solenoid. Check all wiring. Plug in Calibrator and read location 13.01 for more precise fault cause(s).
5 Flash	Motor stall fault. Check motor for damage. Plug in Calibrator and read location 13.10 for more precise fault cause(s).
6 Flash	Accelerator fault. Check all wiring pertaining to the accelerator (pot box) switch. Perform steps 1, 3 and 4 under <i>Troubleshooting with Handheld Calibrator</i> above. Check the Pot box with an analog ohmmeter.
7 Flash	Low or high battery voltage. Check battery voltage with a voltmeter. If battery voltage drops below 15 volts (24 volt system) or 32 volts (48 volt system), the controller will shut down. Read pack voltage both stationary and under hard acceleration if possible. If voltage is good while static, but drops significantly while accelerating, weak or damaged batteries may be the cause.
8 Flash	Over temperature cutout. Call Columbia Technical Support.
9 Flash	Out of range. Call Columbia Technical Support.
10 Flash	Bench test 24 volt main solenoid. Check all wiring. Plug in Calibrator and read location 13.01 for more precise fault cause(s).

Columbia / ParCar OEM Parts  
evtechnicalservices.com

**Vehicle Drives Slowly**

- Check for all physical/visual signs of damage, low tire pressure or jammed linkages.
- Check for brake drag by turning vehicle power off, releasing parking brake, and attempting to roll vehicle a short distance.
- Plug in the Handheld Calibrator and check 5.01, 6.01 and 7.01 for appropriate values (maximum speed settings).
- Perform step 2 in *Troubleshooting with Handheld Calibrator*.
- Check for weak, discharged or damaged batteries, or poor connections.

**Vehicle Drives in Forward or Reverse Only**

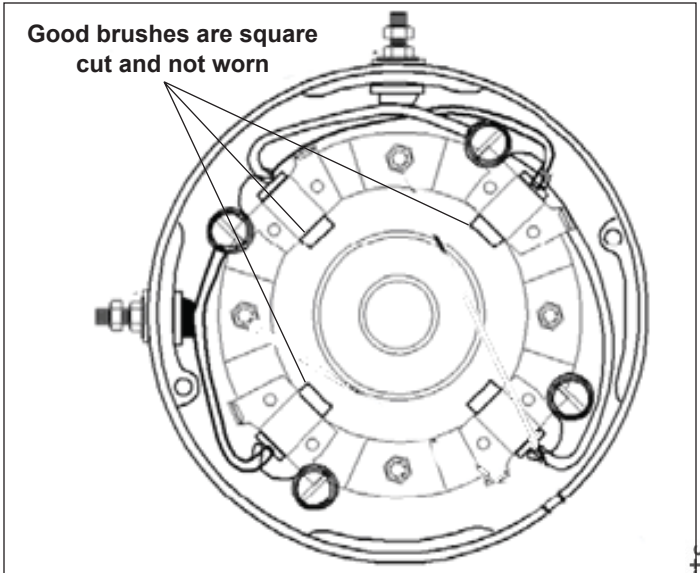
- Perform step 4 in *Troubleshooting with Handheld Calibrator*.

**Vehicle Drives But Operation Is Jerky or Inconsistent**

- Check Pot box carefully with analog ohmmeter for gradual, smooth resistance sweep.
- Check motor brushes. Replace if bad or worn (Figure 4-7).
- Call Columbia Technical Support if problem persists. Have the following information ready:
  - VIN
  - Vehicle Checksum (19.15)
  - Direction of travel the operation is "jerky"
  - Speeds at which vehicle jerks.

**Vehicle Power Cuts Out**

- The fault for a vehicle that exhibits a cut out symptom can only be diagnosed while the vehicle is in a fault condition.



**Figure 4-7. Motor Brushes**

When a vehicle faults, immediately check the flash code, or for fault out location 13.01 to diagnose the cause. Follow the corrective steps. Before calling Technical Support, have the following information ready:

- VIN
- Fault code or fault location
- Battery voltage
- Full description of fault out symptoms (does the vehicle coast to a stop, or stop abruptly, was it travelling uphill, downhill, or on level ground).

**ACEplus SEVCON CONTROLLER POWER SYSTEM - 6 POST**

**IMPORTANT: Always follow troubleshooting guide in exact sequence as listed. Performing tests out of sequence will cause inaccurate results and lost time in diagnosing electrical system problems.**

Troubleshooting Guide		
T est	Passed	Failed
Voltmeter positive red lead to battery B+ terminal, Voltmeter negative black lead to battery B- terminal.	Full battery voltage = Good	Less than full battery voltage, verify battery connections, check for corrosion, state of charge and/or replace batteries.
Turn Tow or Power switch to OFF and then back ON. Observe green LED on controller for flashing pattern. If flashing, count number of flashes and refer to the LED Diagnostic Table on next page.	Contacter will close to start charging controller capacitors and open after approximately 30 seconds.	If contactor does not close, check fuse and wiring to coil. Replacement of a defective controller should always be confirmed by verification that other faults have been eliminated first. Controllers must be factory programmed to specific VIN, axle, tire size and vehicle voltage.
No power to controller.		2005 (and later) vehicles may be equipped with a charger interlock. The green charger wire connects to red wire #15 in main harness and only provides power to system when charger is unplugged from AC power source. (See Rev 3 wiring diagram).

**LED Fault Code Diagnostic Guide**

The Sevcon Controller Flash Code Diagnostic Guide can be used to get an initial indication of a problem. In some cases, there are multiple possible causes for a fault in that category. The causes and verification steps for some fault codes related to system input or circuitry for the drive system are listed. These obvious faults may not require use of the handset or computer interface. In order to perform complete specific fault diagnosis, a Sevcon Controller Customization Utility Handheld Calibrator PN 79001-04, or Computer Interface 79003-04, may be required. Training is required to use these tools.

<b>Sevcon Newer (Beta) 633T45303 Controller - 6 Post</b>			
<b>Green LED Flashes</b>	<b>Possible Fault Condition</b>	<b>Handset ID#</b>	<b>Cause/Test/Failure</b>
0 Flash (no green LED)	Internal MOSFET/Contactor		No power to Pin 1 from Run/Tow or Power Switch. Also see <i>No Power To Controller, Troubleshooting Guide page 4-4.</i>
			No power to contactor coil connections.
			No power from main contactor to controller B+.
			Controller connector wiring open circuit.
			Controller connector pin not in place.
			Dielectric break down at connector (wet/shorted).
		25/26	Internal controller fault, MOSFET problem. Replacement of controller may be required.
1 Flash	Personality (CRC) out of range	17/18	Incorrect range settings; requires Handset/Computer or replacement of controller.
2 Flash	Illegal start condition	various	The wire harness controller connector pins may develop an open or intermittent connection which can also result in these faults. Check pins and crimps.
		7	Seat switch not closed on accelerator depress (when equipped).
		8	Accelerator switch (pedal) needs to be recycled after a direction change.
		9	Pedal depress when key turned on.
		10	Wiring fault - two directions selected.
		11	Forward/Reverse switch turned on at power up.
		11	Speed switch out of adjustment.
		11	Micro switch not open with pedal up.
3 Flash	MOSFET short circuit		External strobe (flasher) light caused fault. Wiring polarity reversed on flasher (Rovr/IS only).
		23	Armature circuit short detected or other intermittent electrical short such as brush dust, etc.
		27	Internal controller fault.
4 Flash	Contactor fault or motor open circuit	19	Contactor failed or stuck. Bench test contactor.
		20	Main post to battery corroded.
		20	Test switched side of contactor.
		20	Test 24 Volt small terminal coil (verify correct coil voltage).
		22	Motor open circuit or brushes.
5 Flash	Motor stall fault	15	Motor stall condition detected.
6 Flash	Accelerator fault	4	Input wire disconnected (white/black lead).
		5	Speed (Pot Box) adjustment required.
		5	Pedal depressed at power up (see 2 Flash).

Columbia / ParCar DEMOParts  
evtechnicalservices.com

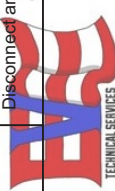


<b>Sevcon Newer (Beta) 633T45303 6 Post Controller - 6 Post (continued)</b>			
<b>Green LED Flashes</b>	<b>Possible Fault Condition</b>	<b>Handset ID#</b>	<b>Cause/Test/Failure</b>
7 Flash	Low or high battery voltage	13/16	End of charge cycle with Power switch left on. Check for BDI scan sweep.
		12/13/16	Battery voltage has fallen or risen: 24 Volt system: 15 V Low - 36.5 V High 36 Volt system: 22.5 Low - 50 V High 48 Volt system: 30 V Low - 65 V High
8 Flash	Over temperature or timed cut out		Defective controller; replacement may be required.
		1	Excessive temperature heat sink.
		3	Current cut-back.
9 Flash	Monitor tripped	2	F1 or A1 out of range boundaries 125%.
10 Flash	Auto zero fault		Contactora coil disconnected.
		34	May be controller internal fault.
		34	Contactora did not operate properly.

NOTE: Fault indication will be cleared by Power-up sequence after fault cause has been corrected.

**Flash Codes and Corrective / Investigative Action (633T45303)**

Flash Code	Description	Action	Handset ID fault number (13.01)	Calibrator reference loc	Correction - If fault does not clear
0 Flash (Light does not illuminate or light turns on and then back off.)	Internal Mosfet failure	Disconnect any electrical accessories and retry	25 / 26	-	Controller replacement required, contact Tech Support
	Pin 1 Circuit Fault	Trace current from battery positive to Pin 1	-	-	Replace failed connection, component, or wiring.
	Contacting Circuit fault	Trace current to solenoid and contact connections	-	-	Replace failed connection, component, or wiring.
1 Flash	Personality out of range	Check personality Checksum	17 / 18	19.15	Controller replacement required, contact Tech Support
2 Flash	Seat Switch Fault	Check Seat switch and Seat switch circuit	7	19.08	Repair or replace failed connection or component
	Accelerator not at rest when direction selected	Ensure Accelerator Pedal returns to 0 (rest) position	8 or 9	19.01 / 19.07	Repair or replace failed connection or component
	Two directions selected	Ensure Direction Key switch is functioning properly	10	19.05 / 19.06	Repair or replace failed connection or component
	Forward or reverse selected at power up	Ensure Direction Key switch is functioning properly	11	19.05 / 19.06	Repair or replace failed connection or component
	Speed Switch out of range	Check speed switch range	11	19.01 / 19.02	Repair or replace failed connection or component
	FS1 not open with pedal up	Ensure Pedal returns to 0 and microswitch is functioning properly	11	19.07	Repair or replace failed connection or component
3 Flash	Controller pins are cross - shorted	Check wire harness connector pins for good connections	Various	19.01 - 19.09	Repair any faulty connections
	Auxiliary wiring short	Disconnect auxiliary electrical components and retry	-	-	Controller replacement required, contact Tech Support
4 Flash	Armature Short Detected	Clean and Check motor and wiring for faults	23	-	Motor replacement may be required, contact Tech Support
	Internal controller fault	Disconnect auxiliary electrical components and retry	27	-	Controller replacement required, contact Tech Support
	Contacting Failed or Stuck	Bench test contactor	19	-	Replace Solenoid, if good - Controller replacement required, contact Tech Support
5 Flash	Contacting Failed or contactor wiring fault	Bench test contactor and test contactor wiring	20	-	Repair or replace failed connection or component
	Motor open circuit or brushes fault	Clean and Check motor and wiring for faults	22	-	Motor replacement may be required, contact Tech Support
	Motor stall detected	Clean and Check motor and wiring for faults review application	15	-	Motor replacement may be required, contact Tech Support
6 Flash	Input wire disconnected	Check wiring to the speed switch and FS1	4	19.01 / 19.07	Repair or replace failed connection or component
	Speed switch out of adjustment	Check speed switch range	11	19.01 / 19.02	Repair or replace failed connection or component
	Pedal depressed at start up	Ensure Accelerator Pedal returns to 0 (rest) position	8 or 9	19.01 / 19.07	Repair or replace failed connection or component
7 Flash	Battery voltage low fault	Check Static battery voltage and voltage while operating	12 / 13 or 16	15.01	Check to see if voltage drops below 32 volts, charge / replace batteries
	Battery voltage high fault	Check Static battery voltage and voltage while operating	12 / 13 or 16	15.01	Check to see if voltage rises above 63 volts in while operating, see SB - 12-07
	Capacitor voltage is too high	Check Static battery voltage and voltage while operating	14	15.02	Contact tech support with reading from 15.02
8 Flash	Over Temperature out - out	Review application and allow vehicle to cool	1	18.01	Contact Tech Support
	Current Cut - Back	Review application and allow vehicle to cool	3	18.01	Contact Tech Support
9 Flash	Internal monitor tripped	Disconnect any electrical accessories and retry	2	-	Controller replacement required, contact Tech Support
10 Flash	Contacting Coil Disconnected	Bench test contactor and test contactor wiring	-	-	Contacting or Controller replacement may be required, contact Tech Support
	Value out of range	Check personality Checksum	34	19.15	Controller replacement may be required, contact Tech Support
	Internal controller fault	Disconnect any electrical accessories and retry	-	-	Controller replacement may be required, contact Tech Support



Columbia / ParCar OEM Parts  
evtechnicalservices.com

**Smartdrive SEVCON CONTROLLER POWER SYSTEM - 5 POST**

**IMPORTANT:** Always follow troubleshooting guide in exact sequence as listed. Performing tests out of sequence will cause inaccurate results and lost time in diagnosing electrical system problems.

<b>Troubleshooting Guide</b>			
<b>T</b>	<b>est</b>	<b>Passed</b>	<b>Failed</b>
	Voltmeter positive red lead to battery B+ terminal, Voltmeter negative black lead to battery B- terminal.	Full battery voltage = Good	Less than full battery voltage, verify battery connections, check for corrosion, state of charge and/or replace batteries.
	Turn Tow or Power switch to OFF and then back ON. Observe green LED on controller for flashing pattern. If flashing, count number of flashes and refer to the LED Diagnostic Table on next page.	Contactors will close to start charging controller capacitors and open after approximately 30 seconds.	If contactor does not close, check fuse and wiring to coil. Replacement of a defective controller should always be confirmed by verification that other faults have been eliminated first. Controllers must be factory programmed to specific VIN, axle, tire size and vehicle voltage.
	No power to controller.		2005 (and later) vehicles may be equipped with a charger interlock. The green charger wire connects to red wire #15 in main harness and only provides power to system when charger is unplugged from AC power source. (See Rev 3 wiring diagram).

Columbia / ParCar OEM Parts  
**evtechnicalservices.com**  
  
TECHNICAL SERVICES

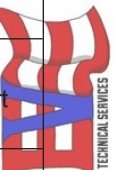
**LED Fault Code Diagnostic Guide**

The Sevcon Controller Flash Code Diagnostic Guide can be used to get an initial indication of a problem. In some cases, there are multiple possible causes for a fault in that category. The causes and verification steps for some fault codes related to system input or circuitry for the drive system are listed. These obvious faults may not require use of the handset or computer interface. In order to perform complete specific fault diagnosis, a Sevcon Controller Customization Utility Handheld Calibrator PN 79001-04, or Computer Interface 79003-04, may be required. Training is required to use these tools.

Sevcon 633T46101 Controller-5 Post			
Green LED Flashes	Possible Fault Condition	Handset ID#	Cause/Test/Failure
0 Flash (no green LED)	Internal MOSFET/Contactor		No power to Pin 1 from Run/Tow or Power Switch. Also see <i>No Power To Controller, Troubleshooting Guide page 4-8.</i>
			No power from main contactor to controller B+.
			Controller connector wiring open circuit.
		23/24/25	Internal controller fault, MOSFET problem. Replacement of controller may be required.
1 Flash	Personality (CRC) out of range	14/15	Incorrect range settings; requires Handset/Computer or replacement of controller.
2 Flash	Illegal start condition	various	The wire harness controller connector pins may develop an open or intermittent connection which can also result in these faults. Check pins and crimps.
			Speed switch (pot box) is out of adjustment. See Section 5.
		6	Seat switch not closed on accelerator depress (when equipped).
		7	Accelerator switch (pedal) needs to be recycled after a direction change.
		9	Wiring fault - two directions selected.
3 Flash	MOSFET short circuit		External strobe (flasher) light caused fault. Wiring polarity reversed on flasher (Rovr/IS only).
		18/22	Internal controller fault. Armature circuit short detected or other intermittent electrical short such as brush dust, etc.
4 Flash	Contactor fault or motor open circuit	16/17	Contactor failed or stuck. Bench test contactor.
5 Flash	Not used		
6 Flash	Accelerator fault	3	Input wire or speed switch fault (white/black lead).
7 Flash	Low or high battery voltage	11/12/13	Battery voltage has fallen or risen: 24 volt system 15 V Low – 36 V High 36 volt system 22.5 V Low – 50 V High 48 volt system 30 V Low – 65 V High
8 Flash	Over temperature or timed cut out		Replacement of controller may be required.
		1	Excessive temperature heat sink.
		2	Current cut-back.

NOTE: Fault indication will be cleared by Power-up sequence after fault cause has been corrected.

Columbia / ParCar OEM Parts  
evtechnicalservices.com



**SPEED SWITCH (POT BOX) TESTING - ALL MODELS**

Speed Switch (Pot Box) Testing		
Test	Passed	Failed
Disconnect white and black lead wires from wire harness to speed switch under front body. Switch volt/ohm meter to ohms scale, capable of measuring 0-100 ohms. Connect volts/ohm meter leads to white and black wires from speed switch. <b>Do not depress accelerator. Leave key in OFF position.</b>	0-50 ohms resistance = Good	Greater than 50 ohms, refer to Pot Switch adjustment. If adjustment does not correct, replace pot switch or speed switch assembly.
Leave ohm meter leads connected to white and black leads (speed switch). Switch ohm meter to a scale capable of measuring up to 6,000 ohms (K ohms). Slowly depress accelerator and monitor change.	Ohms of resistance should rise gradually to a maximum of 4,500 - 5,000 ohms.	If rise in resistance is erratic or skips as pedal is depressed, replace speed switch (pot box) assembly. If maximum resistance is less than or greater than 4,500-5,500 ohms, adjust pot switch to correct.

**COMPONENT TROUBLESHOOTING**

In addition to the problems/cause/solutions listed in this section, individual sections also contain some testing and problem solution for individual components. Check the appropriate section first, and if the information is not found, check the following when a component is causing a problem:

**Battery Discharge Indicator (BDI)**

1. Fuse failed.  
*Check fuse and replace if failed.*
2. Open wiring or failed connection.  
*Check wiring and connections*
3. Inoperable BDI gauge.  
*Replace gauge.*
4. Weak or failed batteries.  
*Test batteries and charge as necessary.*

**Brake Lights and Auxiliary Switch**

1. Fuse failed.  
*Check fuse and replace if failed.*
2. Open wiring or failed connection.  
*Check wiring and connections*
3. Bulb failed.  
*Replace bulb.*
4. Misadjusted or inoperable brake light switch.  
*Check switch adjustment, replace switch if necessary.*

**Flasher Module**

1. Fuse failed.  
*Check fuse and replace if failed.*
2. Open wiring or failed connection.  
*Check wiring and connections*
3. Module failed.  
*Replace module.*

**Reverse Buzzer**

1. Fuse failed.  
*Check fuse and replace if failed.*
2. Open wiring or failed connection.  
*Check wiring and connections*
3. Inoperable reverse buzzer.  
*Replace buzzer.*
4. Weak or failed batteries.  
*Test batteries and charge as necessary.*
5. Controller set wrong.  
*Check controller setting using hand held. Reset if necessary.*
6. Inoperable directional switch.  
*Test switch and replace if necessary.*

**Head Light**

1. Fuse failed.  
*Check fuse and replace if failed.*
2. Open wiring or failed connection.  
*Check wiring and connections*
3. Bulb burnt out.  
*Replace bulb.*
4. Failed power key switch.  
*Test and replace contactor as necessary.*
5. Inoperable rocker switch.  
*Replace rocker switch.*

Columbia / ParCar OEM Parts  
evtechnicalservices.com



**Power Outlet**

1. Fuse failed.  
*Check fuse and replace if failed.*
2. Open wiring or failed connection.  
*Check wiring and connections*
3. Inoperable power outlet.  
*Replace power outlet.*

**Tail Light**

1. Fuse failed.  
*Check fuse and replace if failed.*
2. Open wiring or if failed connection.  
*Check wiring and connections*
3. Bulb burnt out.  
*Replace bulb.*
4. Failed power key switch.  
*Test and replace as necessary.*

**Brakes**

Slow or incomplete release of brakes.

1. Shoes and linings.  
*Shoes improperly adjusted. Shoes are self-adjusting; check parts for wear.  
Shoes distorted or incorrect. Replace with new parts*
2. Mechanical parts.  
*Damaged or weak return springs-replace.  
Cables and linkage sticking, dirty or corroded. Lubricate with a commercial solvent like WD40, PB Blaster, etc. Make sure not to contaminate brake pads with solvent.*

3. Wheel bearings.  
*Damaged or contaminated-replace.  
Grabbing or pulling-replace.*
4. Air in hydraulic lines (hydraulic brakes).  
*Bleed hydraulic lines.*

Severe reaction to pedal pressure and uneven stopping.

1. Shoes and linings.  
*Shoes improperly adjusted. Shoes are self-adjusting; check parts for wear.  
Shoes distorted or incorrect. Replace with new parts*
2. Mechanical parts.  
*Damaged or weak return springs-replace.  
Cables and linkage sticking, dirty or corroded. Lubricate with a commercial solvent like WD40, PB Blaster, etc.*
3. Drums.  
*Drums are thin (expanding when hot); oversize (beyond .030") of original specification – replace.  
Scored, out-of-round – replace*

Squealing, clicking or scraping noises upon application of brakes.

1. Shoes and linings.  
*Shoes twisted, distorted, incorrect or broken – replace.  
Linings worn out, glazed, loose or contaminated – replace*
2. Mechanical parts.  
*Damaged or weak return springs-replace.  
Backing plate loose or failed – replace.*
3. Drums.  
*Drums are thin (expanding when hot); oversize (beyond .030") of original specification – replace.  
Scored, out-of-round – replace*





This page intentionally left blank.

**ACCELERATOR PEDAL ..... 5-2**

**MECHANICAL BRAKE SYSTEM..... 5-2**

    General ..... 5-2

    Periodic Brake Inspection ..... 5-2

    Annual Brake Inspection ..... 5-2

    Mechanical Rear Drum Brake..... 5-3

    Brake Cable Replacement ..... 5-5

    Mechanical Brake Adjustments ..... 5-5

**HYDRAULIC BRAKE SYSTEM..... 5-6**

    General ..... 5-6

    Periodic Brake Inspection ..... 5-6

    Annual Brake Inspection ..... 5-6

    Hydraulic Rear Drum Brake ..... 5-6

    Hydraulic Master Cylinder ..... 5-9

    Hydraulic Front Disc Brake ..... 5-10

    Hydraulic Brake Adjustments ..... 5-12

[evtechnicalservices.com](http://evtechnicalservices.com)  
 Columbia ParCar OEM Parts  
 TECHNICAL SERVICES

## ELECTRIC VEHICLE SERVICE

When servicing the electric vehicle always observe the following:

### **SAFETY FIRST**

**Always turn Power key to OFF, Directional key switch to Neutral, remove Power key, block tires and disconnect the battery negative (-) cable before performing any vehicle service to avoid accidental startup of vehicle and possible personal injury.**

## ACCELERATOR PEDAL

Accelerator pedal maintenance consists of periodic inspection. No lubrication or adjustment is necessary.

The accelerator pedal is connected to the brake pedal with a ratchet and pawl. When the accelerator pedal is depressed, the brake is released and the system is energized.

The accelerator pedal works in conjunction with the linear accelerator and the Sevcon controller to adjust and control vehicle direction and speed.

All adjustments are made using the PCPak or handheld Calibrator. See *Section 4-Troubleshooting*.

## MECHANICAL BRAKE SYSTEM

### General

The mechanical braking system consists of two rear wheel drum brakes, the brake pedal, springs and brake cables to operate the brakes.

A brake equalizer pulls evenly on both brake cables. The brake equalizer floats to create equal tension to each brake cable leading to the rear brake assemblies.

These brakes are self-adjusting and should not require adjustment if shoe-to-drum clearance is within normal limits. When brakes are applied, shoes expand outward to drum. If brake shoe travel is excessive, brake adjuster will advance to compensate for wear. When brakes are released, adjuster returns to normal position.

To check brake operation, operate the vehicle with no load, in a large, clear area. Release the accelerator and apply the brake pedal completely. The vehicle should stop abruptly. If it doesn't, see *Mechanical Brake Adjustments* in this section.

The parking brake is applied by depressing the parking brake pad at the top of the brake pedal which locks the brakes in place. Brakes are released when the accelerator or brake pedal is depressed. If brakes fail to hold the car in position when parking brake is applied, see *Mechanical Brake Adjustments*.

### Periodic Brake Inspection

Intervals between brake service and inspection may vary depending driving habits, type of driving, road and climate conditions, and vehicle load.

### CAUTION

**Periodic brake inspection is required to prevent potential accident or injury and vehicle damage.**

Periodic inspection should always include the following:

1. With vehicle stationary, depress the brake pedal and check for 1/4" pedal free travel before resistance is felt. Maximum pedal free travel should not exceed 2" measured from floor board to top of pedal. If pedal free travel is excessive, see *Mechanical Brake Adjustments*.
2. Inspect brake parts under vehicle for physical damage, corrosion, or cable fraying. Inspect dust boot at brake actuating lever located behind each rear wheel. If cracked or split, replace dust boot.
3. Operate vehicle on level ground, applying brakes to ensure that both rear brakes apply equally. Check that excessive force is not required to apply brakes. Excessive force required to apply brakes could indicate malfunctioning brake linkage or excessive wear to brake shoes.

### Annual Brake Inspection

#### WARNING

**To perform this service, raise vehicle using floor jack and safely support it with jack stands positioned under main frame tubes. See *Section 3 - Lifting Instructions*.**

1. Perform steps 1 & 2 under *Mechanical Rear Drum Brake Disassembly*.
2. Inspect drum for excessive or uneven wear. Look for cracks radiating from stud holes.  
Maximum drum inside diameter is 6.635" (168.4 mm). If drum is worn beyond service limit, or uneven wear is shown, drum must be replaced. See *Brake Drum Service*.
3. Inspect brake shoes for thickness, uneven wear or physical damage. If brake shoe lining at any point is measured to be less than 1/16" (1.6 mm), brake shoes must be replaced. See *Mechanical Rear Drum Brake Disassembly*.
4. Inspect for oil or grease contamination. Replace brake shoes that are contaminated. See *Mechanical Rear Drum Brake Disassembly*.
5. Inspect dust boot at brake actuating lever. If cracked or split, replace dust boot.
6. Wash mud, brake shoe debris, and dirt from brake assemblies and drum. Apply white lithium grease to contact points between brake shoe and brake back plate. Remove excess grease to prevent brake shoe contamination.

### CAUTION

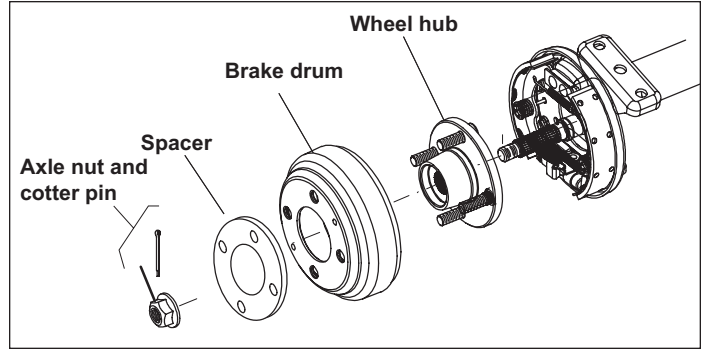
**Do not use compressed air to blow dust from brake assembly. Brake dust contains potentially harmful contaminants.**

7. Perform steps 5-8 under *Mechanical Rear Drum Brake Reassembly*.

**Mechanical Rear Drum Brake**

**MECHANICAL REAR DRUM BRAKE DISASSEMBLY**

- Before removal of existing parts, note location of colored springs and other parts for correct reassembly.
  - Always use a brake spring tool to remove and install springs.
  - Always lay out brake shoes and other parts in order removed. Reinstall in same order.
  - Always replace brake shoes that have been contaminated with oils or lubricants.
  - Always replace any springs that appear stretched or deformed.
1. Engage the brake. Remove four lug nuts and remove rear wheel/tire assembly. Repeat for other rear wheel.
  2. See Figure 5-1. Remove and discard cotter pin and axle nut. Release brake and remove spacer, brake drum and wheel hub.
- Refer to Figure 5-2 for steps 3 - 7.
3. Using good, quality brake pliers, remove auto adjuster spring.
  4. To remove brake shoes, hold 1/4 turn fastener with a brake spring tool, rotate 1/4 turn and remove fastener and spring. Repeat for other 1/4 turn fastener.
  5. Grasp two brake shoes at centers. Pull them outward and fold away from backing plate. Lift one shoe at a time from brake anchor. Remove springs and shoes from brake backing



**Figure 5-1. Rear Brake Drum and Hub**

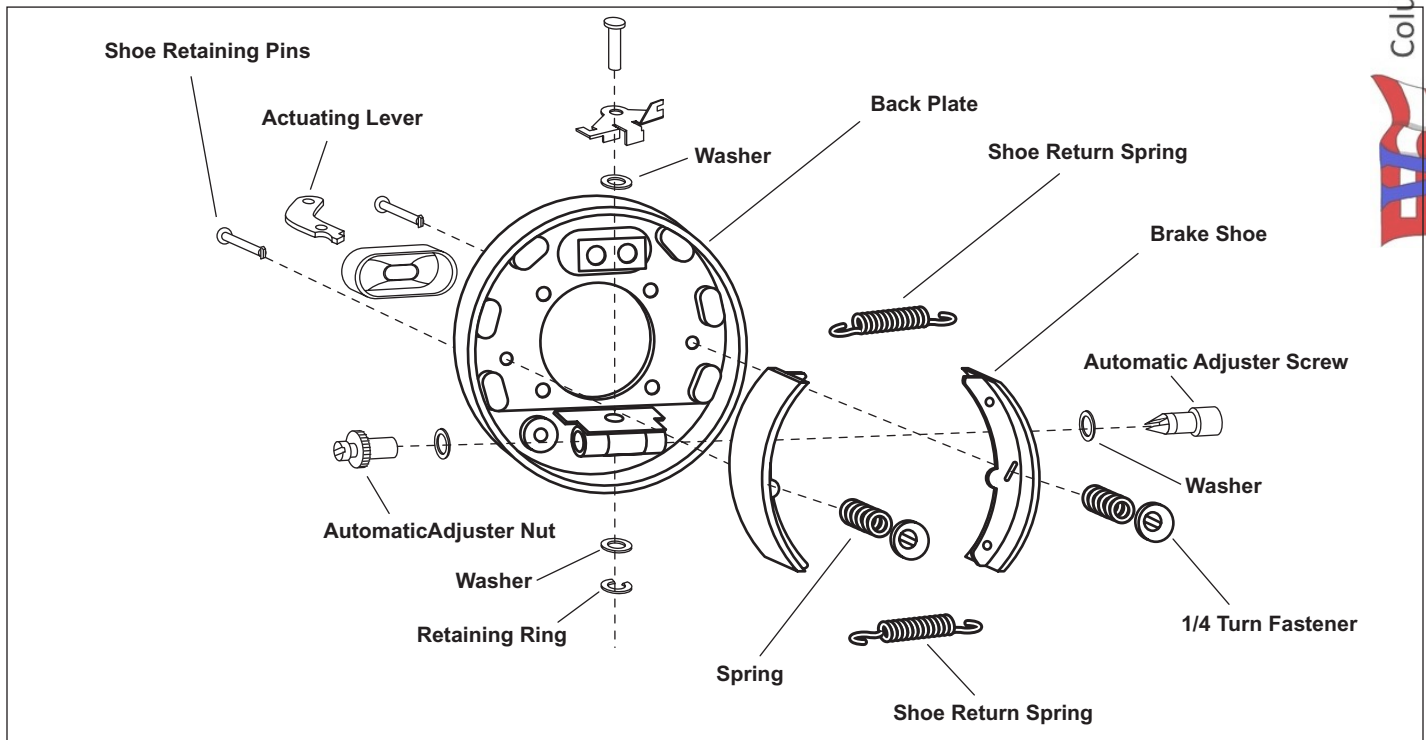
6. Slide the automatic adjuster screw and automatic adjuster nut from brake assembly. Clean these parts thoroughly.
7. Wash any mud, brake debris, and dirt from brake plate.

**CAUTION**

**Do not use compressed air to blow dust from brake assembly. Brake dust contains potentially harmful contaminants.**

**BRAKE DRUM SERVICE**

1. Rebore or replace drum:
  - if rubbing surface is rough or ragged, or if depth of scoring exceeds .010".
  - if inside diameter of drum at open end exceeds inside diameter at closed end by more than .010".



**Figure 5-2. Mechanical Rear Drum Brake - Left Side Shown**

Columbia ParCar OEM Parts  
evtechnicalservices.com



if surface variance exceeds .005" on the side.

if hard spots cause noticeable effects such as pedal pulsations or brake roughness. If spots are severe, replace drum.

if heat checking is plainly visible or can be felt with a fingernail. If checks are severe, replace drum.

if out-of-round condition exceeds .006" total indicator reading or if pedal pulsations or brake roughness is noticeable.

- To measure a drum diameter, place gauge in drum so contact points are at greatest diameter. Be careful to hold both contact points at same depth (distance from outside edge of drum).
- Rebore limit is .060" over original drum diameter.
- Difference in diameter of drums on opposite ends of the same axle must not exceed .010", or when turning drums turn them in pairs to same oversize (within .010") to ensure equal braking effort on all wheels.

**CAUTION**

**Never rebore a drum to maximum wear or discard diameter.**

- When reboring a drum, remove only enough metal to obtain a smooth, true braking surface. If drum does not clean up when turned to maximum rebore diameter, replace it. Removal of more metal will affect ability of drum to dissipate heat and may cause drum distortion.

**MECHANICAL REAR DRUM BRAKE REASSEMBLY**

- Apply a small amount of white lithium grease to the threads of automatic adjuster screw and to contact points where brake shoes rest against back plate.
- Install automatic adjuster screw and nut into automatic adjuster assembly. Reconnect top and bottom shoe return springs to brake shoes in same order as removed.

Brake shoes may not be equal in length. The shoe with the shorter lining should be installed on the brake assembly side closest to the front of the vehicle. Shoe with longer lining installs to the rear.

- See Figure 5-2. With the springs attached to the brake shoes, hook bottom of each brake shoe, one at a time, into slots on automatic adjuster screw and opposing retainer. Next, hook top end of each brake shoe behind anchor at the top of brake plate. Fold ends of shoes inward towards brake plate. Secure them in place with brake shoe pins, retainer springs and 1/4 turn fasteners.
- Install auto adjuster spring. Using a flat blade screwdriver, turn the adjuster nut away from the backing plate. Check to make sure the shoes are spreading further apart. Make sure the brake drum still slides on easily.
- Install the brake drum 3/4 over the brake assembly and using a brake spoon or brake adjusting tool, rotate the brake adjuster until drag is felt against the brake drum. Push the drum fully onto the assembly.

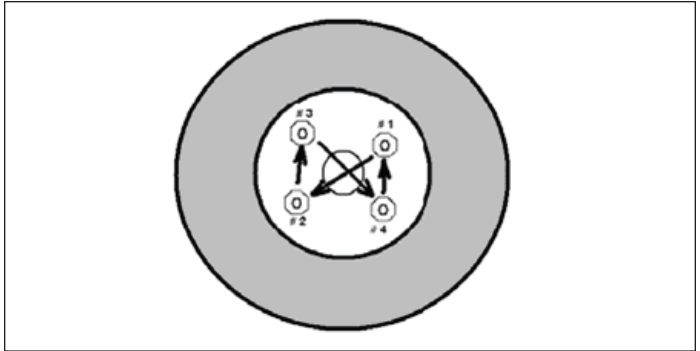


Figure 5-3. Lug Nut Tightening Pattern

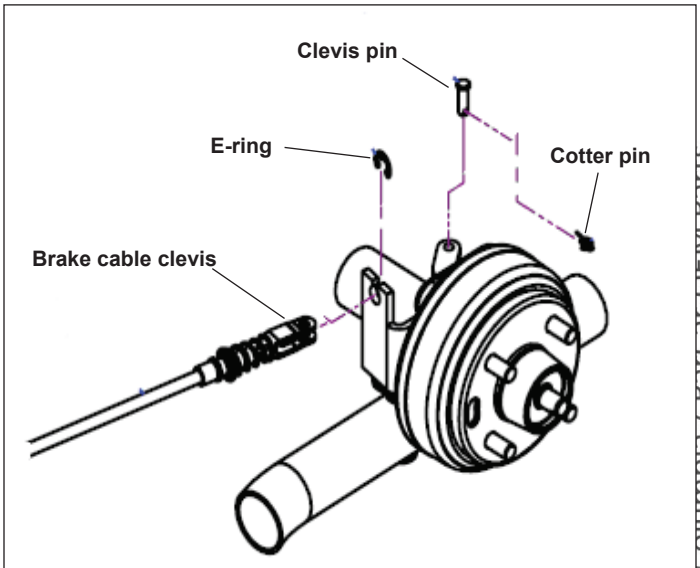


Figure 5-4. Brake Cable Rear Mounting

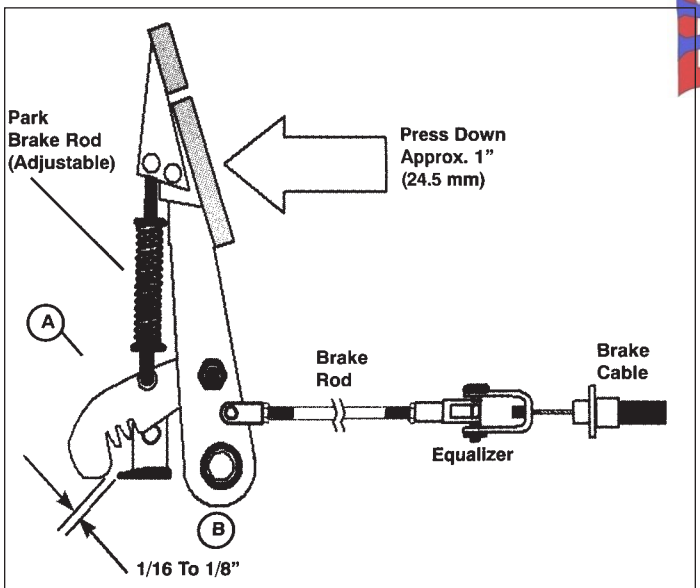


Figure 5-5. Mechanical Brake Adjustment



6. Apply pressure to the brake pedal and release, then check to see if additional adjustment is required to create drag on the drums.
7. When adequate drag is achieved (very slight drag), install wheel hub and drum fully onto brake assembly and install spacer. Engage brake and install a new axle nut. Tighten axle nut to a minimum 65 ft. lbs. (23 Nm) Install new cotter pin.
8. Reinstall rear wheel/tire assembly and four lug nuts. Engage brake and tighten lug nuts in a criss-cross pattern to a maximum 65-70 ft. lbs. (23-25 Nm) (Figure 5-3). Repeat for other rear wheel. Recheck lug nut torque with vehicle on the ground.

### Brake Cable Replacement

#### ▲ WARNING

To perform this service, raise vehicle using floor jack and safely support it with jack stands positioned under main frame tubes. See Section 3 - Lifting Instructions.

1. At rear brake assembly (Figure 5-4), remove cotter pin, clevis pin and e-ring (23) from brake cable clevis. Discard cotter pin and e-ring.
2. Remove cable clevis from rear wheel brake actuator arm. Cut cable tie securing brake cables to frame.
3. Remove brake cable from equalizer (Figure 5-5).
4. Repeat for other cable.
5. In order to install new cables, it may be necessary to loosen equalizer on brake rod (Figure 5-5). Note position of jamnut on equalizer and mark with tape. Loosen jamnut on rod end to provide slack to brake cable.
6. Install brake cable ends at brake equalizer.
7. Route brake cables to rear axle brake actuator arms (Figure 5-4). Secure cable clevis end to each arm with clevis pin and new cotter pin. Secure cable sheath with new e-ring.
8. Secure brake cables to frame with new cable tie.
9. Tighten nut on brake rod (Figure 5-5) to position marked in step 5. With vehicle stationary, depress the brake pedal and check for 1/4" pedal free travel before resistance is felt. Maximum pedal free travel should not exceed 2" measured from floor board to top of pedal. If adjustment is required, see *Mechanical Brake Linkage Adjustment* below.
10. Operate vehicle on level ground, applying brakes to ensure that both rear brakes apply equally. Check that excessive force is not required to apply brakes. Excessive force required to apply brakes could indicate malfunctioning brake linkage or excessive wear to brake shoes.

### Mechanical Brake Adjustments

#### MECHANICAL BRAKE LINKAGE ADJUSTMENT

*NOTE: Correct brake operation should be confirmed before adjustments are made to cables and mechanical linkage. Check that corrosion has not caused excessive resistance in the operation of the brake cables. If corrosion is present, replace cables before performing adjustments.*

1. Loosen jamnuts on brake rod connecting brake pedal to equalizer.
2. Rotate brake rod to shorten or lengthen it. Adjust length of brake rod until free brake pedal movement is less than 1/4".
3. Tighten jamnuts.

#### MECHANICAL PARKING BRAKE PEDAL ADJUSTMENT

After rear brake operation is tested, and brake linkage and cables are properly adjusted, check and adjust the parking brake as follows:

1. Look through the floor opening while gently pressing on the brake pedal. The gap between the brake ratchet end and the brake ratchet pawl should be no greater than 1/16"-1/8" (Figure 5-5).
2. If adjustment is required, remove the clevis pin securing the brake rod to the brake pedal. If the gap between the parking brake ratchet and the brake pawl is less than 1/16", shorten the rod slightly to adjust. If the gap is greater than 1/8", lengthen the rod to adjust.
3. Reconnect the brake rod to the parking brake pedal. Recheck the space to verify correct gap.
4. Depress the parking brake pedal until the first click is heard. At this setting the vehicle should not roll when on a slight incline. Depress the pedal to the second click, or notch. With the parking brake set, the vehicle should not roll on a steep incline or hill.
5. With the gap properly set, if the vehicle does move on when performing steps 4 & 5, perform the *Mechanical Brake Linkage Adjustment* above.

#### MECHANICAL DRUM BRAKE SHOE ADJUSTMENT

These brakes are self-adjusting and require no manual adjustment. If brakes do not adjust automatically, check brake cable adjustment or inspect brake assembly for internal damage or friction.



**HYDRAULIC BRAKE SYSTEM**

**General**

The hydraulic brake system utilizes a combination of mechanical and hydraulic components and are equipped with rear drum brakes. In addition, vehicles can also be equipped with additional front disc brakes.

A mechanical brake pedal and linkage is utilized to actuate a master cylinder. The master cylinder creates hydraulic pressure which operates the brakes. Hydraulic brake systems require a separate mechanical parking brake. A hand operated parking brake, mechanical linkage and cables are utilized to mechanically lock the rear brakes for parking. An optional hydraulic pressure sensor (Figure 5-6) is used on some vehicles to operate the rear brake lights.

**CAUTION**

**Do not handle hydraulic system parts with greasy hands or permit parts to come in contact with oil or grease. Grease or oil will damage the rubber parts.**

**Periodic Brake Inspection**

Intervals between brake service and inspection may vary depending driving habits, type of driving, road and climate conditions, and vehicle load.

**CAUTION**

**Periodic brake inspection is required to prevent potential accident or injury and vehicle damage.**

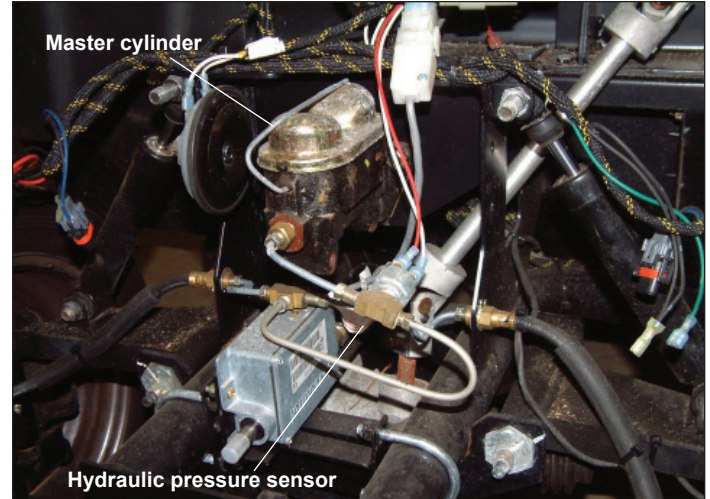
Periodic inspection should always include the following:

1. With vehicle stationary, depress the brake pedal. Pedal should not travel in excess of 2-1/2" as measured from floor board. If pedal travels in excess of 2-1/2" before resistance is felt, or if pedal feels spongy and soft, repair or maintenance is required.
2. Inspect brake master cylinder and adjoining brake lines for signs of fluid leakage. Remove master cylinder cover (Figure 5-6). Fluid must be clear and fluid level should be within 1/2" of cylinder top (with vehicle on level ground).
3. Check parking brake operation. Parking brake hand lever should travel no more than 3-1/2" upward when engaged. Check that ratchet mechanism automatically holds parking brake handle in up position. Make sure release button on handle frees the parking brake lever and that lever returns to full down (released) position.
4. Operate vehicle on level ground, applying brakes to ensure that both rear brakes apply equally. Check that excessive force is not required to apply brakes. Excessive force required to apply brakes could indicate malfunctioning brake system or excessive wear to brake shoes.

**Annual Brake Inspection**

**WARNING**

**To perform this service, raise vehicle using floor jack and safely support it with jack stands positioned under main**



*Figure 5-6. Hydraulic Brake Master Cylinder*

frame tubes. See Section 3 - Lifting Instructions.

1. Perform steps 1 & 2 under *Hydraulic Rear Drum Brake Disassembly*.
2. Inspect drum for excessive or uneven wear. Refer to *Brake Drum Service*. Look for cracks radiating from stud holes.
3. Inspect brake shoes for thickness, uneven wear or physical damage. If brake shoe lining at any point is measured to be less than 1/16" (1.6 mm), brake shoes must be replaced. See *Hydraulic Rear Drum Brake Disassembly*.
4. Inspect for oil or grease contamination. Replace brake shoes that are contaminated. See *Hydraulic Rear Drum Brake Disassembly*.
5. Inspect wheel cylinder area for fluid leakage. Inspect axle and axle tube area for leakage from axle bearing.
6. Wash mud, brake shoe debris, and dirt from brake assemblies and drum. Apply white lithium grease to contact points between brake shoe and brake back plate. Remove excess grease to prevent brake shoe contamination.

**CAUTION**

**Do not use compressed air to blow dust from brake assembly. Brake dust contains potentially harmful contaminants.**

7. Perform steps 5-8 under *Hydraulic Rear Drum Brake Reassembly*.

**Hydraulic Rear Drum Brake**

**HYDRAULIC REAR DRUM BRAKE DISASSEMBLY**

**NOTICE**

**It is not recommended to remove the hydraulic brake assembly from the axle for repair or service.**

- Before removal of existing parts, note location of colored springs and other parts for correct reassembly.
- Always use a brake spring tool to remove and install springs.

Columbia / ParCar OEM Parts  
evtechnicalservices.com  
TECHNICAL SERVICES

- Always lay out brake shoes and other parts in order removed. Reinstall in same order.
- Always replace brake shoes that have been contaminated with oils or lubricants.
- Always replace any springs that appear stretched or deformed.
- Never use petroleum based cleaners or lubricants on hydraulic brake parts as they will contaminate the brake fluid.

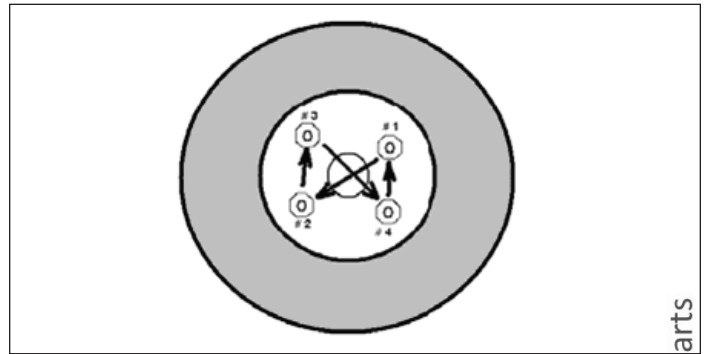
**NOTICE**

**Do not mix parts from left and right brake assemblies as they may differ.**

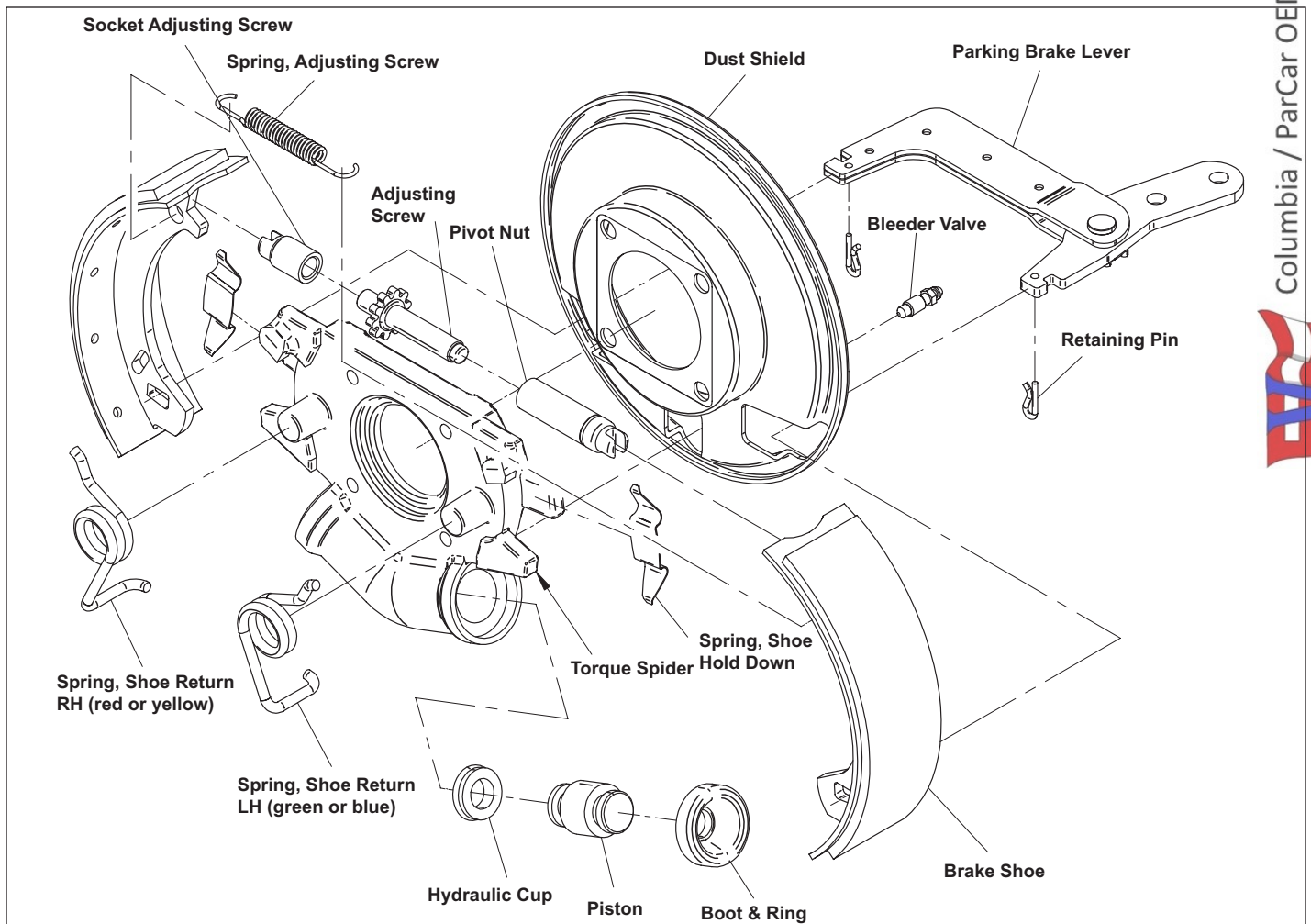
1. Engage the brake. Remove four Tinnerman nuts and remove rear wheel/tire assembly. Repeat for other rear wheel.
  2. Release brake and remove brake drum.
- Refer to Figure 5-7 for steps 3 - 6.
3. Use a brake spring tool and remove the shoe return springs. Carefully pry the top of each spring from behind its tab on the torque spider. Unhook each spring from the torque spider and

brake shoe and set it aside.

4. Remove the blue spring holding the top of each brake shoe together against the adjuster. Remove the adjuster screw and nut.
5. Gently remove each clip securing the brake shoes to the park actuating lever. Remove the brake shoes.



**Figure 5-8. Lug Nut Tightening Pattern**



**Figure 5-7. Rear Hydraulic Brake Assembly**

**▲CAUTION**

**Do not depress brake pedal while shoes and drum are removed from the vehicle. Pistons will be forced from the wheel cylinders causing fluid leakage and damage.**

6. Clean the brake assembly to remove brake debris, dust, dirt and mud.
7. See *Brake Drum Service* and rebore/replace drum as necessary.
8. See *Wheel Cylinder Service* and rebuild/replace as necessary.

**▲CAUTION**

**Do not use solvents or other chemical cleaners unless formulated for cleaning brake parts.**

**Do not use compressed air to blow dust from brake assembly. Brake dust contains potentially harmful contaminants.**

**BRAKE DRUM SERVICE**

1. Rebore or replace drum:
  - if rubbing surface is rough or ragged, or if depth of scoring exceeds .010".
  - if inside diameter of drum at open end exceeds inside diameter at closed end by more than .010".
  - if surface variance exceeds .005" on the side.
  - if hard spots cause noticeable effects such as pedal pulsations or brake roughness. If spots are severe, replace drum.
  - if heat checking is plainly visible or can be felt with a fingernail. If checks are severe, replace drum.
  - if out-of-round condition exceeds .006" total indicator reading or if pedal pulsations or brake roughness is noticeable.
2. To measure a drum diameter, place gauge in drum so contact points are at greatest diameter. Be careful to hold both contact points at same depth (distance from outside edge of drum).
3. Rebore limit is .060" over original drum diameter.
4. Difference in diameter of drums on opposite ends of the same axle must not exceed .010", or when turning drums turn them in pairs to same oversize (within .010") to ensure equal braking effort on all wheels.

**▲CAUTION**

**Never rebore a drum to maximum wear or discard diameter.**

5. When reboring a drum, remove only enough metal to obtain a smooth braking surface. If drum does not clean up when turned to maximum rebore diameter, replace it. Removal of more metal will affect ability of drum to dissipate heat and may cause drum distortion.

**WHEEL CYLINDER SERVICE**

The wheel cylinder is a one piece cast assembly and is part of the torque spider. When servicing the wheel cylinder, it is not necessary to remove it from the vehicle. Removal of the torque spider

and wheel cylinder is recommended only when replacement is required. To remove, see *Section 7 - Rear Axle and Rear Wheel Assemblies*.

Rebuild or replace wheel cylinder/torque spider whenever brake shoes are replaced, or more often when required to correct a leaking cylinder.

*Cleaning and Inspection*

1. Whenever a wheel cylinder is disassembled, always inspect the cylinder bore for scoring, pitting and corrosion. A hard, crystal-like substance sometimes forms a ring in the cylinder bore near the place where the piston stops, when brakes are released.
2. Fine grade crocus cloth (or an approved cylinder hone) may be used to remove light roughness or deposits from the bore. Hone lightly and use brake fluid as a lubricant while honing. If the bore does not clean up readily, replace the cylinder.
3. After using crocus cloth or a hone, flush inside of cylinder with clean alcohol or brake fluid, and wipe dry with a lint-free cloth. Be sure all dust and grit are removed and bleeder valve and brake tube passages are clean.
4. The clearance between cylinder bore wall and pistons must be checked after the cylinder is cleaned up. If a narrow (1/18" - 1/4" wide) .006" feeler gauge can be inserted between the bore wall and a new piston, the clearance is excessive and the wheel cylinder must be replaced.

*NOTE: If the clearance between the pistons and the bore wall exceeds .005", a condition known as heel drag may exist. This causes rapid cup wear and may cause the pistons to retract very slowly when the brakes are released.*

5. Tips for assembly:
  - Always use new wheel cylinder repair parts to rebuild wheel cylinder.
  - Dip the pistons and cups in clean brake fluid. Coat the cylinder bore with clean brake fluid.
  - Refer to Figure 5-7 for reassembly.
  - After reassembly is complete, hydraulic system must be bled of air. See *Bleeding the Hydraulic System*.

**HYDRAULIC REAR DRUM BRAKE REASSEMBLY**

1. Place brake shoes into position on brake actuating lever tabs. Insert retaining pins.
  - Brake shoes may not be equal in length. The shoe with the shorter lining should be installed on the brake assembly side closest to the front of the vehicle. Shoe with longer lining installs to the rear.
2. Screw adjuster assembly into minimum length position and insert between the tops of each brake shoe. Install blue spring under adjuster.
3. Insert the red spring into the left shoe (facing the brake assembly) onto its mounting post on the brake spider, and pry the top end of the red spring into position behind the torque spider retaining tab. Repeat with green spring mounted on the



right side.

4. Check that brake shoes are correctly positioned into the slots provided in each master cylinder piston.
5. Install the brake drum 3/4 over the brake assembly and using a brake spoon or brake adjusting tool, rotate the brake adjuster until drag is felt against the brake drum. Push the drum fully onto the assembly.
6. Apply pressure to the brake pedal, pumping 2-3 times and releasing, then check to see if additional adjustment is required to create drag on the drum. Adjust as necessary to achieve slight drag on the drum.
7. When adequate drag is achieved (very slight drag), install drum fully onto brake assembly and install four new Tinnerman nuts.
8. Reinstall rear wheel/tire assembly and four lug nuts. Engage brake and tighten lug nuts in a criss-cross pattern to a maximum 65-70 ft. lbs. (23-25 Nm) (Figure 5-8). Repeat for other rear wheel. Recheck lug nut torque with vehicle on the ground.

## Hydraulic Master Cylinder

### BRAKE FLUID MAINTENANCE

1. Maintain fluid level within 1/4" of master cylinder filler opening (Figure 5-6).

2. Changing brake fluid:

As a result of use, brake fluid loses some of its original qualities and may become contaminated. When performing major brake work to the hydraulic system, remove old fluid and replace it with clean brake fluid.

Brake fluid must be changed following extended usage or contamination. Anytime fluid looks milky or dark, there are contaminants in the fluid.

If any of the hydraulic system parts are corroded, or the fluid is discolored, flush the hydraulic system to remove old fluid, then fill with clean brake fluid.

3. Soft or swollen rubber parts, or milky or discolored fluid indicate the brake fluid is contaminated.

Drain old fluid from the system.

Replace cups and seals.

Flush hydraulic system with clean brake fluid.

Refill system with clean brake fluid.

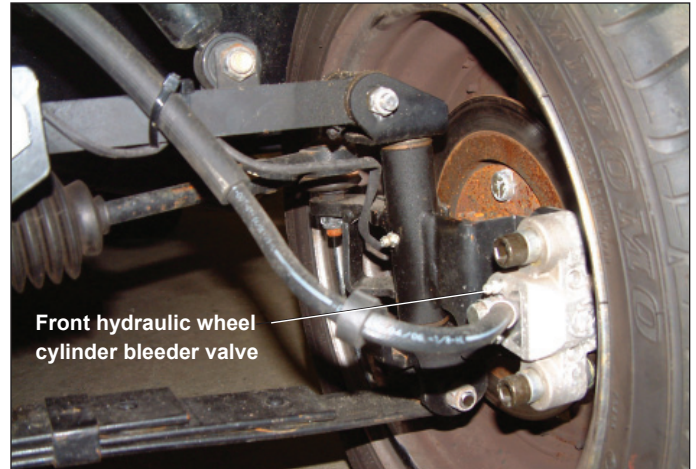
4. Handling and storing brake fluid:

Keep brake fluid clean. Do not allow any foreign material in the fluid.

Prevent any petroleum product (gasoline, kerosene, oil, grease, etc.) from contaminating the brake fluid.

Use only clean containers for dispensing brake fluid.; Do not use containers contaminated with dirt, grease, etc.

Always cover or cap brake fluid containers when not actually



**Figure 5-9. Hydraulic Brake Caliper Bleeder Valve**

dispensing the fluid. If containers are left open or uncovered, the fluid absorbs moisture from the air.

Never reuse old brake fluid drained from the system. Used brake fluid is contaminated to some extent.

Store brake fluid containers in a clean, dry place.

### BLEEDING THE HYDRAULIC SYSTEM

#### ▲ WARNING

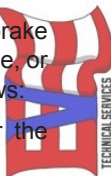
**Brake fluid can cause irritation of eyes and skin, and may be harmful if swallowed. If fluid is swallowed, induce vomiting by administering two tablespoons of salt in a glass of warm water. Call a doctor. In case of contact with skin or eyes, flush with plenty of water. Get medical attention for eyes. KEEP BRAKE FLUID OUT OF THE REACH OF CHILDREN!**

If any line or cylinder has been opened when servicing the brake system, or when satisfactory brake adjustment is unobtainable, or pedal is spongy, bleed air from the hydraulic system as follows:

1. Install a length of appropriate size plastic tubing over the wheel cylinder bleeder valve (Figure 5-9).

*NOTE: On vehicles equipped with only rear hydraulic brakes, bleed the right side wheel first. On vehicles equipped with both front and rear hydraulic brakes, bleed both right side wheels first, then both left side wheels.*

2. Place the other end of tubing in any clear glass jar containing about 1/2" of brake fluid.
3. Open bleeder valve by rotating it counterclockwise about 1/2 turn. With master cylinder full of fluid at all times, slowly depress the brake pedal repeatedly until fluid flows from bleeder valve free of air bubbles.
4. Add fluid to master cylinder to bring 1/4" from cover. Close bleeder valve. Repeat procedure on left wheel.
5. Do not reuse fluid unless it is clear and free of sediment. If it is impossible to bleed all air from system, master cylinder is faulty and a master cylinder repair kit should be installed.



**Hydraulic Front Disc Brake**

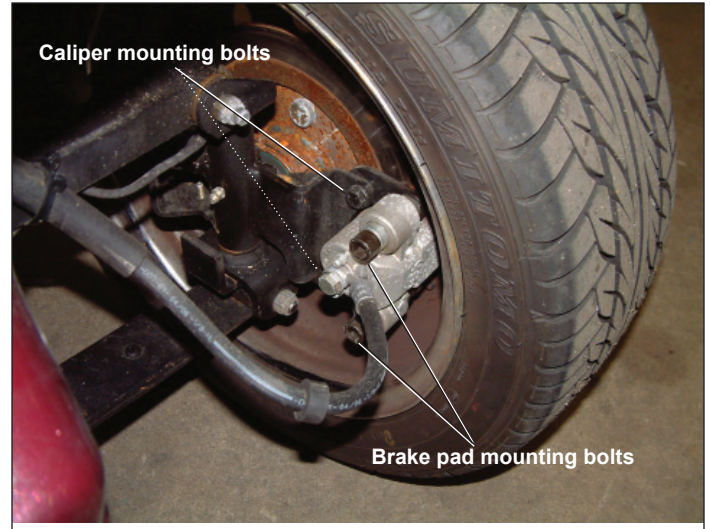
Disc brakes are not adjustable and rarely cause problems. If problems are encountered, refer to the following service and inspections procedures for possible causes and solutions.

**REPLACING BRAKE PADS**

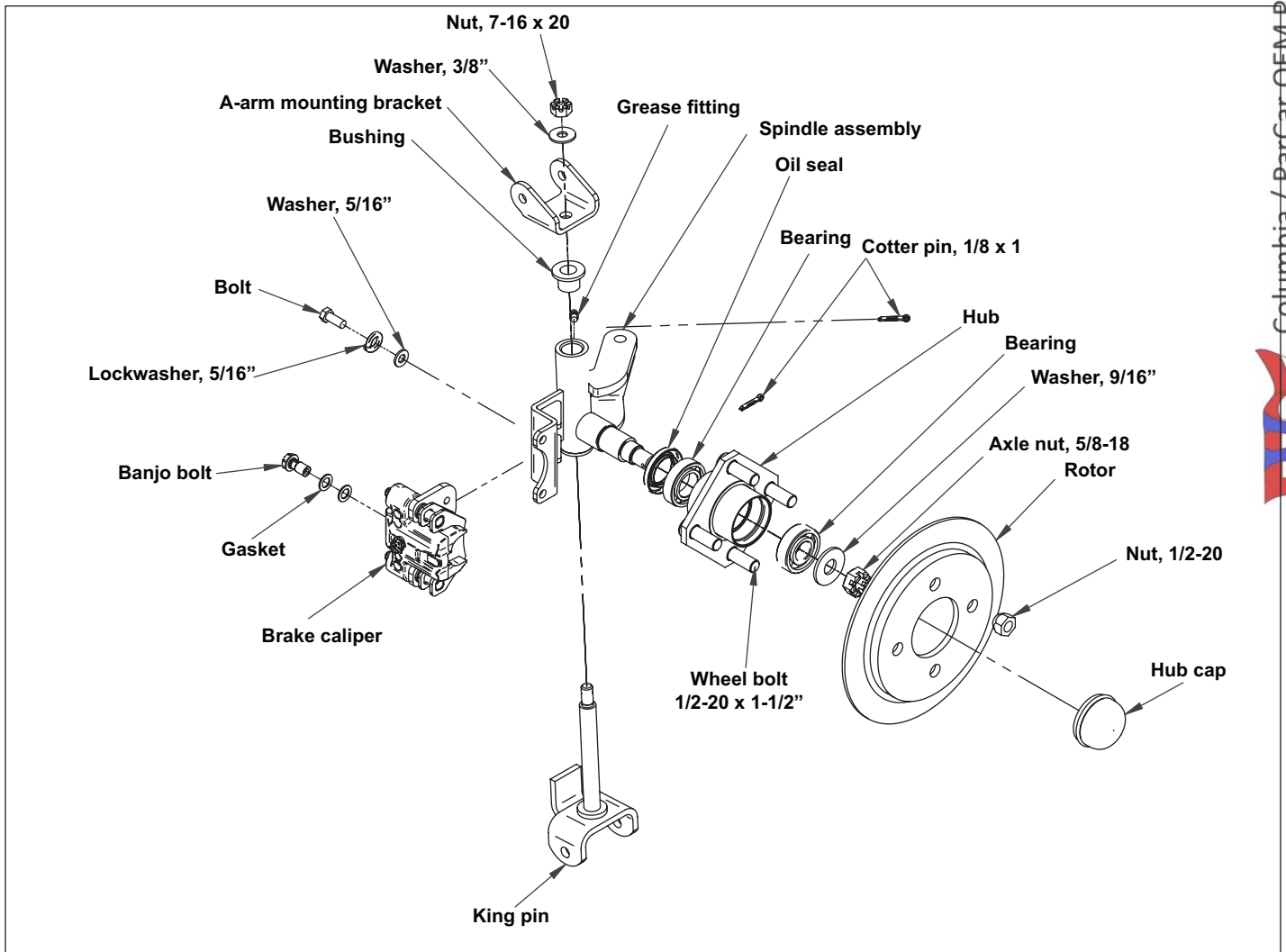
**⚠CAUTION**

Do not depress brake pedal while brake pads are removed from the vehicle. Pistons will be forced from the wheel cylinders causing fluid leakage and damage.

1. With vehicle on the ground, depress the brake pedal to engage the brakes. Loosen wheel assembly mounting nuts.
2. Raise and secure vehicle as described in *Section 3-Lifting Instructions*.
3. Remove four nuts and front wheel/tire assembly.
4. Disengage the brakes and remove brake caliper mounting hardware (Figure 5-10).



**Figure 5-10. Hydraulic Parking Brake Adjustment**



**Figure 5-11. Hydraulic Front Disc Brake**



5. Remove brake pad mounting bolts (Figure 5-10).
6. Remove old pads and replace with new pads.
7. Reinstall brake pad mounting hardware and tighten.
8. Reinstall caliper to bracket with mounting hardware.
9. Repeat steps 4 - 8 for other front wheel.
9. Reinstall rear wheel/tire assembly and four lug nuts. Engage brake and tighten lug nuts in a criss-cross pattern to a maximum 65-70 ft. lbs. (23-25 Nm) (Figure 5-8). Recheck lug nut torque with vehicle on the ground.

**BRAKE CALIPER SERVICE**

The pistons must be removed from the bores. Using the vehicle's hydraulic pressure to force them out is the easiest method.

1. With vehicle on the ground, depress the brake pedal to engage the brakes. Loosen wheel assembly mounting nuts.
2. Raise and secure vehicle as described in *Section 3-Lifting Instructions*.
3. Remove four nuts and front wheel/tire assembly.
4. Disengage the brakes and remove the upper brake caliper mounting bolt (Figure 5-11).
5. Remove brake pad mounting bolts and brake pads (Figure 5-10).
6. Rotate the caliper off the rotor. With caliper still bolted to the vehicle and hydraulic lines connected, press brake pedal until both pistons slide out of the bores. Push one side out, then remove piston from the other side.  
  
To prevent brake fluid from squirting out, cover the calipers with a cloth.
7. Remove the seals and boots. Rubber dust boots and seals should be replaced whenever the caliper is disassembled.
8. Clean pistons in alcohol, then wipe dry with a clean lint-free cloth.
9. Blow out all drilled passages with compressed air.
10. Inspect cylinder bores in both sides of the caliper housing for scoring and pitting. Bores that show light corrosion can be cleaned with fine grit crocus cloth. Caliper bores with deep scratches or scoring should be honed with a 1/4" electric drill. The same attachment is used for honing wheel cylinders on drum brakes.  
  
The caliper cylinder must not be honed out large than the manufacturer's specifications-not more than .002" oversize.
11. Black stains on the bore caused by piston seals are not harmful and need not be removed.

12. After honing, take care in cleaning the caliper parts. Flush them with alcohol, wipe dry with a clean lint-free cloth, then flush and dry them again. Clean mating surfaces with No. 400 wet or dry sandpaper, **never** use a file.
13. Lubricate internal areas, pistons and piston O-rings with new brake fluid. Install parts into caliper.
14. Install brake pads and secure with mounting bolts.
15. Rotate caliper with rotor centered in brake pads and install caliper upper mounting hardware (Figure 5-11).
16. Reinstall rear wheel/tire assembly and four lug nuts. Engage brake and tighten lug nuts in a criss-cross pattern to a maximum 65-70 ft. lbs. (23-25 Nm) (Figure 5-8).
17. Perform all steps in *Bleeding the Hydraulic System*.
18. Recheck lug nut torque with vehicle on the ground.

**BRAKE ROTOR SERVICE**

Disc must be flat with no warping or hot spots. Runout in a disc brake rotor is like out-of-roundness in a drum brake. It causes a loss of brake pedal height because of extra lining clearance. Runout wears the caliper pistons and seats rapidly due to the high speed pulsations created whenever the brakes are applied.

Runout tolerances are critical, usually only about .002".

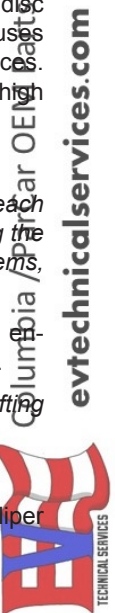
*NOTE: As much as .015" of metal can be removed from each side of the rotor without exceeding specifications. If removing the maximum specified amount will not clean up a rotor's problems, install new rotors.*

1. With vehicle on the ground, depress the brake pedal to engage the brakes. Loosen wheel assembly mounting nuts.
2. Raise and secure vehicle as described in *Section 3-Lifting Instructions*.
3. Remove four nuts and front wheel/tire assembly.
4. Remove brake caliper mounting hardware and brake caliper (Figure 5-10).

**▲CAUTION**

**Do not depress brake pedal while brake caliper is removed from the vehicle. Pistons will be forced from the wheel cylinders causing fluid leakage and damage.**

5. Remove rotor assembly from front axle.
6. Perform rotor service or replace rotor.
7. Reinstall rotor with rotor positioned between the brake pads.
8. Reinstall front wheel/tire assembly and four lug nuts. Engage brake and tighten lug nuts in a criss-cross pattern to a maximum 65-70 ft. lbs. (23-25 Nm) (Figure 5-8). Recheck lug nut torque with vehicle on the ground.





## Hydraulic Brake Adjustments

### HYDRAULIC BRAKE LINKAGE ADJUSTMENT

Gently depress brake pedal and check for free movement before master cylinder piston is depressed. If there is no free travel in the pedal before the master cylinder plunger begins to move, or if the free travel of the pedal exceeds 3/8", adjustment of the brake rod will be required.

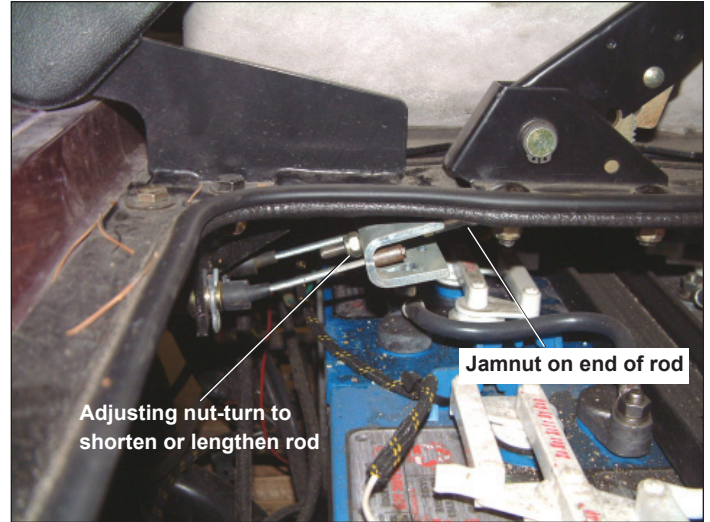
1. Remove cotter pin and clevis pin from brake clevis at brake rod.
2. Rotate brake rod clevis accordingly to decrease or increase free play as required.
3. Reconnect brake rod clevis with clevis pin and new cotter pin.
4. Recheck brake pedal for correct free movement.

### MECHANICAL PARKING BRAKE PEDAL ADJUSTMENT

*NOTE: Correct parking brake operation should be confirmed before adjustments are made to cables and mechanical linkage. Check that corrosion has not caused excessive resistance in the operation of the brake cables. If corrosion is present, replace cables before performing adjustments.*

Lift up the parking brake handle to monitor the amount of travel. The handle should click or ratchet two or more times before resistance is felt and the parking brake is set. If the brake handle rises in excess of 3-1/2" from its original down position, brake cable and linkage adjustment is required as follows:

1. Parking brake rod linkage is connected to the brake equalizer, located under the seat (Figure 5-12).
2. Loosen jamnut securing the brake clevis to the rod. Turn adjusting nut to shorten or lengthen rod as required, then re-tighten jamnut.
3. Recheck parking brake operation to confirm adjustment.



**Figure 5-12. Hydraulic Parking Brake Adjustment**

**GENERAL .....6-2**

**SPECIFICATIONS.....6-2**

**FRONT WHEELS AND HUBS .....6-2**

    Removing Front Wheels and Hubs .....6-2

    Inspecting/Replacing Wheel Hub Bearings .....6-2

    Installing Front Wheel Hubs and Wheels .....6-2

**TIRES .....6-4**

    General .....6-4

    Removing Tire .....6-4

    Installing Tire .....6-4

**STEERING WHEEL .....6-5**

    Removing Steering Wheel .....6-5

    Installing Steering Wheel .....6-5

**RACK AND PINION STEERING ASSEMBLY .....6-5**

    Removing Rack and Pinion Steering Assembly .....6-5

    Disassembling Rack and Pinion Steering Assembly .....6-5

    Assembling Rack and Pinion Steering Assembly .....6-6

    Installing Rack and Pinion Steering Assembly .....6-6

**FRONT SUSPENSION SYSTEM.....6-6**

    Replacing Shock Absorbers .....6-6

    Replacing Front Leaf Spring .....6-6

    Disassembling Kingpin, Steering Arm and A-Arm.....6-6

    Assembling Kingpin, Steering Arm and A-Arm .....6-7

**STEERING AND FRONT SUSPENSION ADJUSTMENTS.....6-7**

    Camber Adjustment.....6-7

    Toe In Adjustment.....6-7



**ELECTRIC VEHICLE SERVICE**

When servicing the electric vehicle always observe the following:

**⚠ SAFETY FIRST ⚠**

**Always turn Power key to OFF, Directional key switch to Neutral, remove Power key, block tires and disconnect the battery negative (-) cable before performing any vehicle service to avoid accidental startup of vehicle and possible personal injury.**

**GENERAL**

The steering system is operated by rotating the steering wheel. The steering wheel rotates the steering shaft connected to the rack and pinion steering assembly. The rack and pinion assembly pushes and pulls on tie rod ends to control front wheel steering.

The front suspension consists of two shock absorbers and a leaf spring.

**SPECIFICATIONS**

Steering Gear Rack and Pinion	
- Automotive type totally enclosed lifetime lubrication	
Camber-Mechanical Adjustment	
- Wheels at right angle to the ground .....	0°
Toe-In Adjustment.....	1/4" (6.4mm) toe-in
Tie Rod Nuts.....	25-28 ft. lbs. (3.5-3.9 kgm)
Steering Gear Unit	
Frame Mounting Bolts .....	31-33 ft. lbs. (4.3-4.6 kgm)
Steering Shaft Clamp Bolts .....	10-15 ft. lbs. (1.4-2 kgm)
Leaf Spring-to-King Pin Bolt.....	35-40 ft. lbs. (4.8-5 kgm)
Steering Wheel Nut .....	22-25 ft. lbs. (3-3.5 Kgm)

**NOTICE**

**Always inspect the condition of vehicle steering components before making adjustments. Worn, broken or damaged parts must be replaced before proper adjustment can be performed.**

**FRONT WHEELS AND HUBS**

**Removing Front Wheels and Hubs**

1. Before raising vehicle, with wheels on the ground, break loose the lug nuts.

**⚠ WARNING**

**To perform this service, raise vehicle using floor jack and safely support it with jack stands positioned under main frame tubes. See Section 3 - Lifting Instructions.**

2. Remove lug nuts and wheel assembly from the hub.
3. Remove grease cap (Figure 6-1)

4. On vehicles equipped with front disc brakes, remove caliper top mounting bolt and rotate caliper off of rotor. Remove rotor.
5. Remove cotter pin, axle nut and flat washer. Discard axle nut and cotter pin.
6. Carefully pull hub (9) off the axle.
7. Repeat steps 1 - 5 for the other front wheel.

**Inspecting/Replacing Wheel Hub Bearings**

**ROLLER BEARINGS**

Front wheel hubs on vehicles not equipped with disc brakes have roller bearings. Bearings should be replaced whenever wheel hub is removed.

Pack bearings with lithium wheel bearing grease before installing.

**SEALED BEARINGS**

Front wheel hubs on vehicles equipped with disc brakes have sealed bearings. They cannot be repacked and must be replaced if damaged. Bearings should be replaced whenever wheel hub is removed. Never reuse a sealed bearing once its been removed from the wheel hub. Replace with a new bearing.

1. Set hub on blocks, in a press, with grease seal on the bottom.
2. Match up a socket to the outside diameter of the bearing.
3. Carefully press out the bearing. Grease seal will be removed also.
4. Clean the hub. Inspect the hub for galling, rust, or metal residue. Replace hub if it is damaged.
7. Support hub in a press. Carefully press in new bearings. Install bearing with larger diameter to inside of wheel hub. Bearing with smaller diameter to the outside of wheel hub.

**NOTICE**

**Press on the outside of the bearing rim and not on the inside parts, or the bearing will be destroyed.**

8. Apply a quality wheel bearing grease to inside of wheel hub and around bearings. Carefully install grease seal to inside of hub.

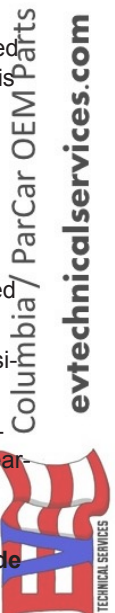
**Installing Front Wheel Hubs and Wheels**

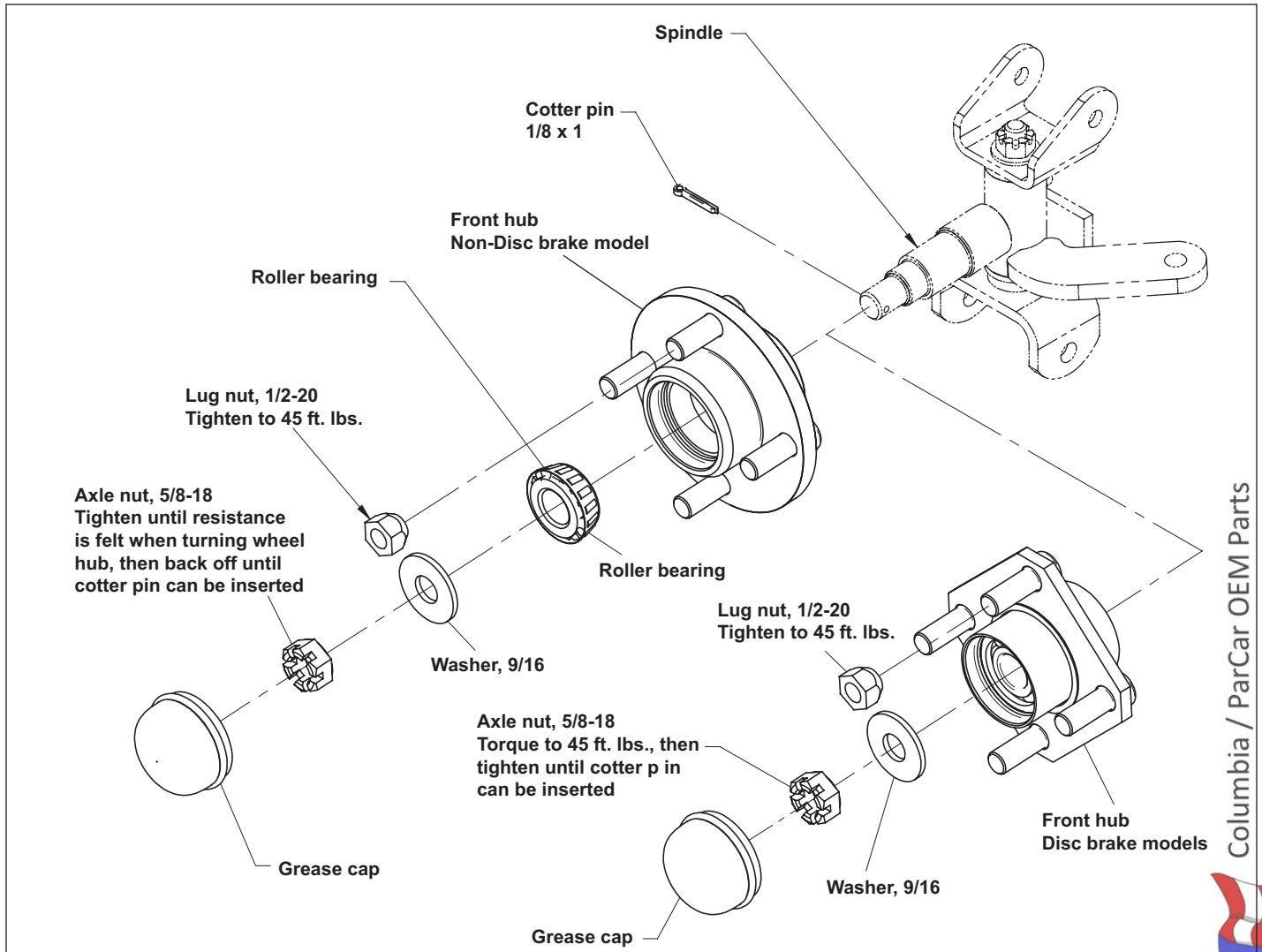
1. Clean spindle. Apply a thin coating of grease and install hub onto the spindle.
2. Install flat washer and new axle nut.

**Disc Brake Models:** Torque axle nut to 45 ft. lbs. then tighten until new cotter pin can be inserted.

**Non-Disc Brake Models:** Tighten axle nut until resistance is felt when turning the wheel hub, then back off until new cotter pin can be inserted.

3. Install grease cup.
4. Place wheel assembly on the hub studs.

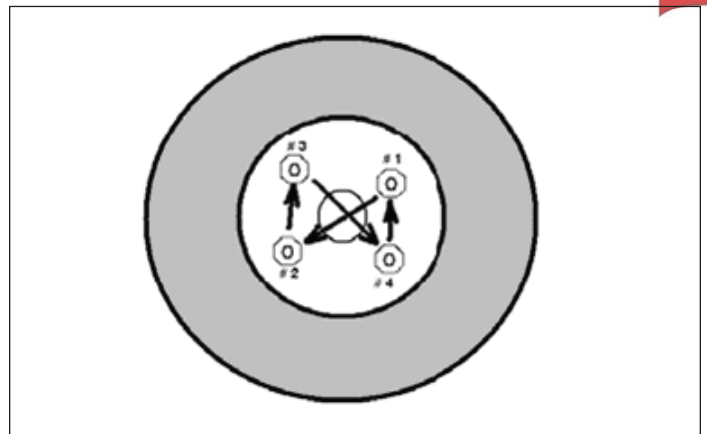




Columbia / ParCar OEM Parts  
evtechnicalservices.com

**Figure 6-1. Front Wheel Hub Assembly**

5. Tighten four lug nuts by hand and wrench until snug using a criss-cross pattern (Figure 6-2).
6. Lower the vehicle to the ground and torque the lug nuts to 65 ft. lbs. (23 Nm) using the same criss-crossing pattern.



**Figure 6-2. Lug Nut Tightening Pattern**

**TIRES**

**General**

In the event of a flat tire, remove wheel assembly from vehicle. Inflate tire to 20 psi (1.33Atm). Immerse wheel assembly in water to determine point of leak. Mark leak location. If tire can be repaired, use the following procedure to remove and install tire.

**Removing Tire**

*NOTE: Tire must be removed from valve stem side of wheel.*

1. Remove wheel assembly from vehicle.
2. Remove valve cap and valve core to deflate tire.
3. If tire machine is unavailable, lay wheel assembly on ground (valve stem side up) and break the tire bead from the wheel (Figure 6-3).
4. Pry the tire off the wheel flange and push into the wheel well (Figure 6-4).
5. Apply tire mounting lubricant to tire bead. With valve stem side up, carefully start upper bead over wheel flange with a flat tire tool. When top bead is free from wheel, pry lower bead over wheel flange (Figure 6-4).

**Installing Tire**

**▲ WARNING**

**Keep hands, fingers, etc. from exposed areas between tire bead and wheel while mounting or inflating tire.**

*NOTE: Tire must be installed to wheel from valve stem side.*

**IMPORTANT! Cleaning tire and wheel is very important, as tubeless tires require a perfect seat to seal.**

1. Clean tire beads to remove dirt and foreign matter Use a wire brush to clean wheel where the bead seats.
2. Check valve stem. Replace worn or leaking stems.
3. Apply liberal amount of tire mounting solution to both tire and wheel.
4. Install tire on wheel from valve stem side. If tire machine is unavailable, use rubber mallet and tire iron to install tire on wheel.
5. Remove valve stem core and position tire so the bead is seated on bead area.
6. Place tire upright against a wall and push against tire on opposite side (Figure 6-5). This three-point contact will bring bead out to contact wheel and bead snaps into place as air is applied.

**▲ WARNING**

**Use care when inflating a tire with a high pressure air supply. Due to low pressure requirements of a small tire, over inflation may be reached in a matter of seconds. Over inflation could cause the tire to explode resulting in possible personal injury.**

7. Apply high pressure air through valve stem. 30-35 psi should be used to seat tire bead.
8. Quickly remove air pressure and install valve stem core.

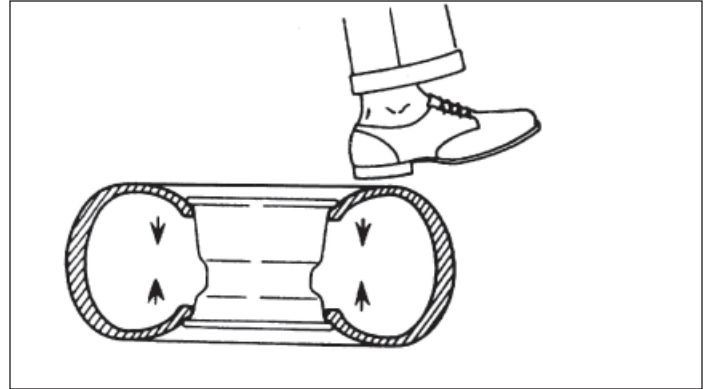


Figure 6-3. Breaking Tire Bead

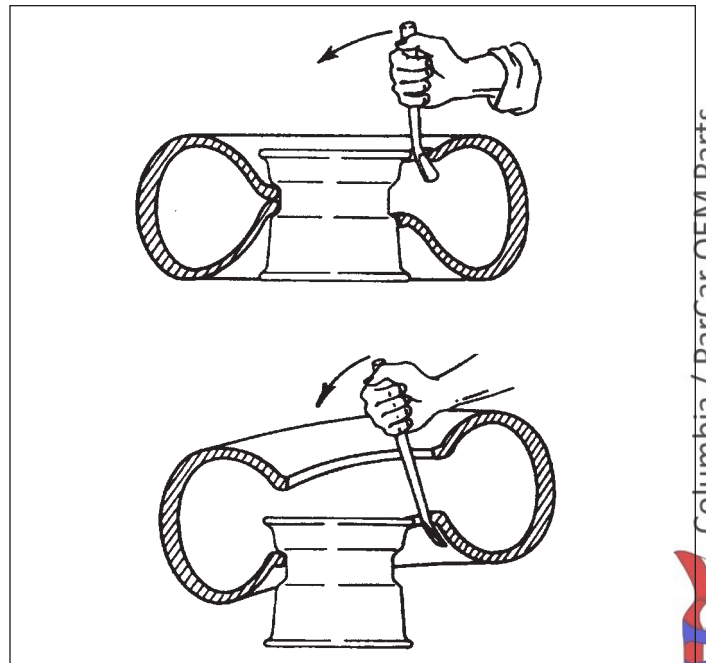


Figure 6-4. Removing Tire

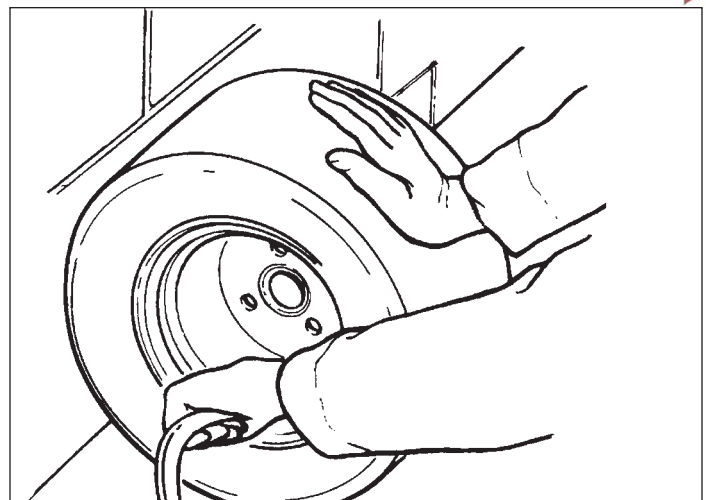


Figure 6-5. Inflating Tire



9. Inflate tire to correct tire pressure (listed on tire sidewall) and immerse wheel/tire assembly in water to check for leaks.
10. Place wheel assembly on the hub studs.
11. Tighten four lug nuts by hand and wrench until snug using a criss-cross pattern (Figure 6-2).
12. Lower the vehicle to the ground and torque the lug nuts to 65 ft. lbs. (23 Nm) using the same criss-crossing pattern.

## STEERING WHEEL

### Removing Steering Wheel

1. Remove steering wheel cover by carefully prying out from steering wheel.
2. Remove two Phillips head screws securing steering wheel to collar (Figure 6-6).
3. Remove steering wheel nut from center of steering wheel.
4. Pull steering wheel from splined shaft.

### Installing Steering Wheel

1. Make sure wheels are pointed straight ahead.
2. Apply Anti-Seize to steering shaft. Install steering wheel centered on splined shaft.
3. Install steering wheel nut and torque to 22-25 ft. lbs. (3-3.5 Kgm).
4. Connect collar to steering wheel with two Phillips head screws.

## RACK AND PINION STEERING ASSEMBLY

### Removing Rack and Pinion Steering Assembly

1. Remove front body as described in *Section 8-Body and Chassis*.
2. Remove steering shaft clamp bolt securing steering shaft to pinion gear (Figure 6-7).
3. Remove nuts securing tie rod ends to left and right steering arm assemblies (Figure 6-8). Lift tie rod ends from steering arms.
4. Remove three bolts securing rack and pinion steering assembly to frame (Figure 6-9).
5. Remove steering assembly from frame.

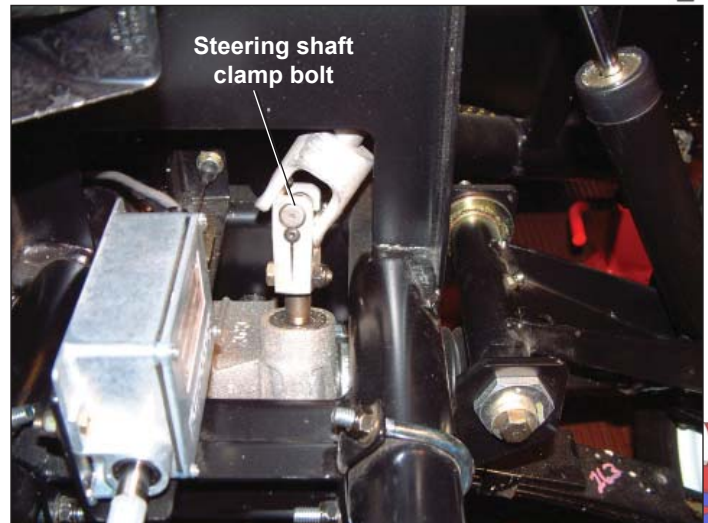
### Disassembling Rack and Pinion Steering Assembly

Refer to Figure 6-11 for the following steps.

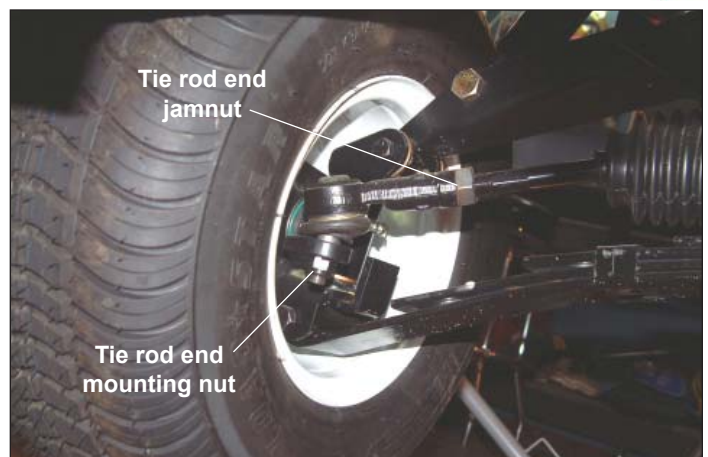
1. Remove oil seal from pinion gear.
2. Remove large retaining ring from steering housing and lift pinion gear from housing.
3. Remove tie rod ends, with jamnuts, from tie rods.
4. Remove clamps from boot ends and slide boots from housing.
5. Using a chisel, bend both lock tabs away from both tie rod ball joints. Unscrew tie rod ball joints from rack gear.
6. Remove rack gear from housing.



**Figure 6-6. Steering Wheel Collar Mounting**



**Figure 6-7. Steering Shaft Connected to Pinion Gear**



**Figure 6-8. Tie Rod End Mounting**

- Clean all parts in cleaning solvent.

### Assembling Rack and Pinion Steering Assembly

Refer to Figure 6-11 for the following steps.

- Using a good quality wheel bearing grease, liberally lubricate all steering parts and inside of steering housing.
- Insert rack gear into housing. Insert pinion gear into top of steering housing and align pinion gear to rack gear.
- Insert retaining ring to lock pinion gear and bearing into steering housing. Make sure retaining ring is fully seated into housing before continuing.
- Apply additional grease over pinion bearing, then insert oil seal over pinion gear.
- Thread tie rod with retaining washer and lockwasher into rack gear end. Use Loctite on threaded areas. Tighten ball joint and bend lock tab against ball joint to prevent loosening. Repeat for other side.
- Install tie rod ends, with jamnuts, to tie rods.
- Liberally grease ball joints. Slide boots over tie rods and clamp to housing.
- Perform adjustments in *Steering and Suspension Adjustments*.

### Installing Rack and Pinion Steering Assembly

- Insert the steering assembly into the frame. Do not install mounting bolts at this time.
- Insert steering assembly pinion gear into steering shaft clamp and install clamp bolt (Figure 6-7). Torque to 10-15 ft. lbs. (1.4-2 Kgm).
- Install three mounting bolts through frame and into steering housing (Figure 6-9) and secure with nuts. Torque to 31-35 ft. lbs. (4.3-4.6 Kgm).
- Install tie rod ends to steering arm assemblies (Figure 6-8). Install nuts and torque to 25-28 ft. lbs. (3.5-3.9 Kgm).

## FRONT SUSPENSION

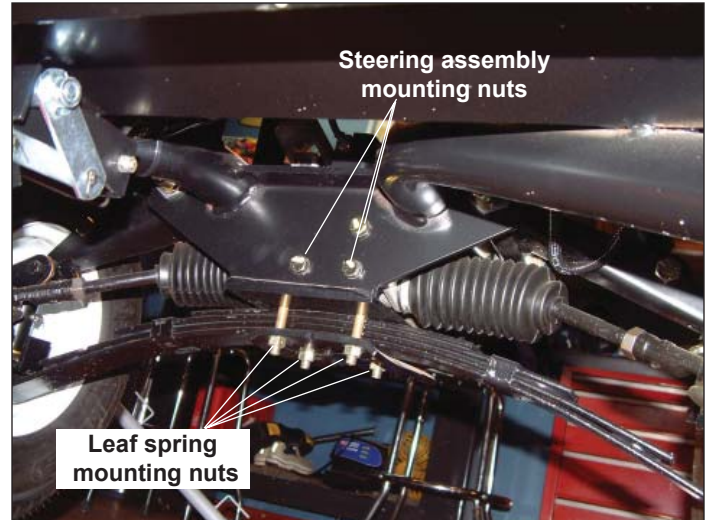
### Replacing Shock Absorbers

Replace shock absorber if dampening affect is not present when shock absorber is collapsed or extended, or there are signs of oil leakage.

- Remove upper and lower mounting bolts and nuts securing shock absorber.
- Install new shock absorber and secure with mounting bolts and new nylock nuts.

### Replacing Front Leaf Spring

- Remove front wheels as described in *Removing Front Wheels and Hubs*.
- Remove bolts and nuts securing kingpins to leaf spring (Figure 6-12).
- Remove four mounting nuts securing leaf spring retainer plate and remove leaf spring (Figure 6-9).



**Figure 6-9. Steering Assembly Mounting To Frame**



**Figure 6-10. Shock Absorber Mounting**

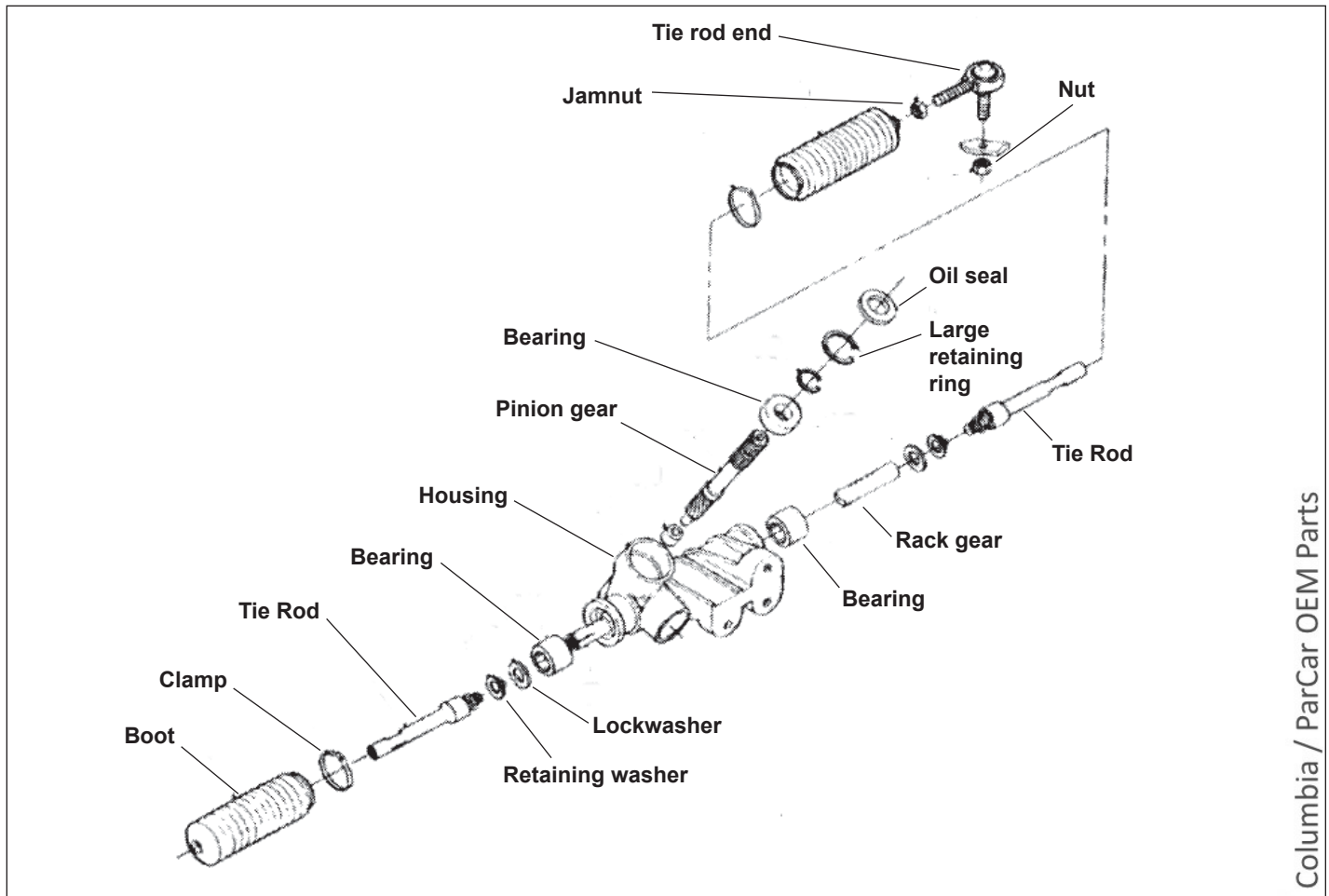
- Install new leaf spring and secure with mounting plate and four nuts.
- Securing leaf spring to kingpins with mounting bolts and nuts. Torque to 40 ft. lbs. (5.52 Kgm).

### Disassembling Kingpin, Steering Arm and A-Arm

Refer to Figure 6-12 for the following steps.

- Remove front wheels and hubs as described in *Removing Front Wheels and Hubs*.
- Remove tie rod end from steering arm (Figure 6-8).
- Remove bolts and nuts securing kingpins to leaf spring.
- Remove cotter pin, kingpin nut and washer securing kingpin to A-arm bracket and remove kingpin and steering arm (Figure 6-12). Discard cotter pin and kingpin nut.
- Remove bolt and nut securing A-arm bracket to A-arm.
- Remove bolt, spacers, washers, camber adjusters, and nut securing A-arm to frame.





Columbia / ParCar OEM Parts  
evtechnicalservices.com

**Figure 6-11. Rack and Pinion Assembly**

### Assembling Kingpin, Steering Arm and A-Arm

Refer to Figure 6-12 for the following steps.

1. Re-install A-arm to frame using hardware removed previously in step 6.
2. Install A-arm mounting bracket, spacer and washers to A-arm with bolt and nut.
3. Install steering arm and kingpin to A-arm bracket with washer and new kingpin nut. Torque nut to 30 ft. lbs. (4.1 Kgm).
4. Connect kingpin to leaf spring with bolt and nut. Torque to 35-40 ft. lbs. (4.8-5 Kgm).
5. Install front hubs and wheels as described in *Installing Front Hubs and Wheels*.
6. Perform adjustments as described in *Steering and Suspension Adjustments*.

### STEERING AND SUSPENSION ADJUSTMENTS

To perform adjustments, place vehicle on flat, level surface. Position front wheels pointed directly forward.

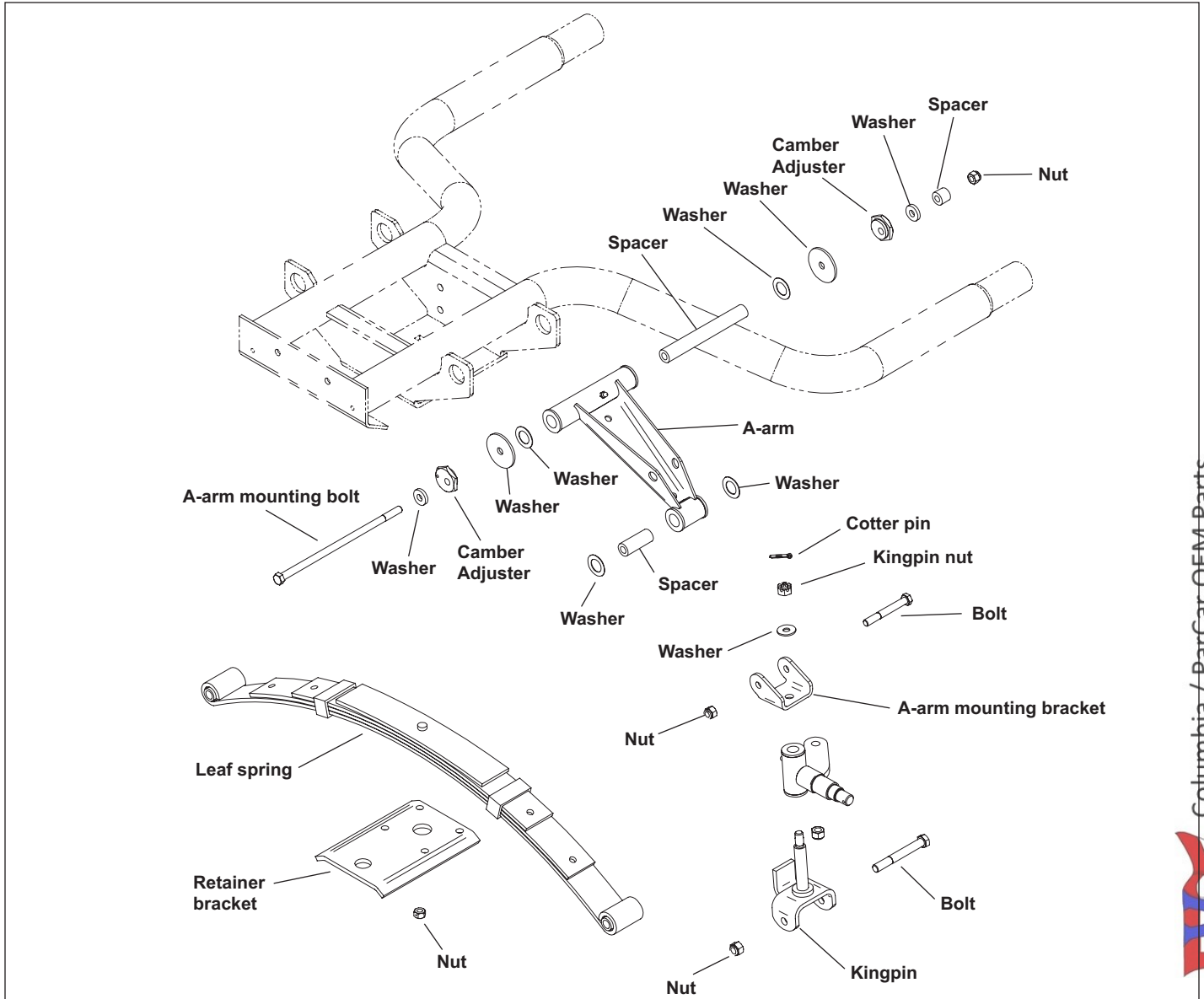
**NOTE:** Always check that camber is correct before performing wheel toe adjustment.

#### Camber Adjustment

1. Each camber adjuster has a dimple in the same position (Figure 6-13). Check that both camber adjusters (dimples) are set in the same position.
2. Place a carpenter's square against left front wheel and check that wheel is straight up and down.
3. If wheel is not vertical, loosen A-arm mounting bolt (Figure 6-12). Rotate both camber adjusters equally until wheel is straight up and down.
4. When correct adjustment is obtained, torque A-arm mounting bolt (Figure 6-12) to 25 ft. lbs. (3.5 Kgm).
5. Repeat for right front wheel.

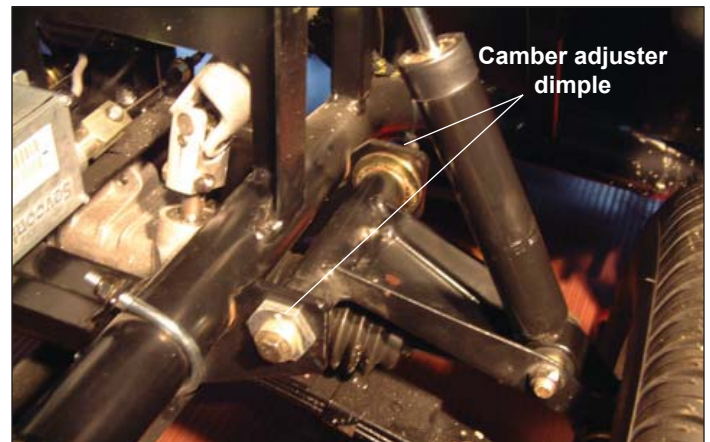
#### Toe In Adjustment

1. With wheels pointed directly forward, loosen jamnuts on tie rod ends (Figure 6-8).
2. Using a rod or stick approximately 27"-27½" long, check dis-



**Figure 6-12. Kingpin, A-arm and Steering Arm Assembly**

- tance between front edge of both tires. Then check the distance between back edge of both tires.
3. The distance between tires at front edge should be 1/4" - 1/8" less than the distance between the back edge of the tires.
  4. If distance between tires (toe in - toe out) is incorrect, rotate tie rods to adjust as necessary.
  5. When correct distance is achieved, tighten tie rod jamnuts against tie rods.
  6. Recheck measurements.



**Figure 6-13. Camber Adjusters**

**REAR WHEELS** ..... 7-2  
     Removing Rear Wheels ..... 7-2  
     Rear Axle Wheel Bearings ..... 7-2  
     Installing Rear Wheels ..... 7-2

**TIRES** ..... 7-2

**REAR SUSPENSION** ..... 7-2  
     Replacing Rear Shock Absorbers ..... 7-2  
     Replacing Rear Springs ..... 7-2  
     Replacing Rear Frame Bushings ..... 7-3

**REAR AXLE ASSEMBLY** ..... 7-3  
     Removing Rear Axle ..... 7-3  
     Disassembling Rear Axle ..... 7-6  
     Assembling Rear Axle ..... 7-9  
     Installing Rear Axle ..... 7-11

**REAR AXLE DIFFERENTIAL OIL** ..... 7-12  
     Changing Differential Oil ..... 7-12

Columbia ParCar O-EM Parts  
**evtechnicalservices.com**  
  
TECHNICAL SERVICES



**ELECTRIC VEHICLE SERVICE**

When servicing the electric vehicle always observe the following:

**⚠ SAFETY FIRST ⚠**

**Always turn Power key to OFF, Directional key switch to Neutral, remove Power key, block tires and disconnect the battery negative (-) cable before performing any vehicle service to avoid accidental startup of vehicle and possible personal injury.**

**REAR WHEELS**

**⚠ WARNING**

To perform this service, raise vehicle using floor jack and safely support it with jack stands positioned under main frame tubes. See Section 3 - Lifting Instructions.

**Removing Rear Wheels**

1. Before raising vehicle, with wheels on the ground, break loose the lug nuts (Figure 7-1).
2. Raise the vehicle and engage the brake. Remove four lug nuts and remove rear wheel/tire assembly. Repeat for other rear wheel.
3. Repeat steps 1 - 2 for the other rear wheel.

**Rear Axle Wheel Bearings**

Rear axle wheel bearings are sealed type bearings and cannot be repacked. Bearings must be replaced if worn or damaged. Refer to *Disassembling Rear Axle* for bearing replacement procedures.

**Installing Rear Wheels**

1. Place wheel assembly on the hub studs.
7. Tighten four lug nuts (Figure 7-1) by hand and wrench until snug using a criss-cross pattern (Figure 7-2).
8. Lower the vehicle to the ground and torque the lug nuts to 65 ft. lbs. (23 Nm) using the same criss-crossing pattern.

**TIRES**

See Section 6-Tires for tire removal, repair and mounting.

**REAR SUSPENSION**

**⚠ WARNING**

To perform this service, raise vehicle using floor jack and safely support it with jack stands positioned under main frame tubes. See Section 3 - Lifting Instructions.

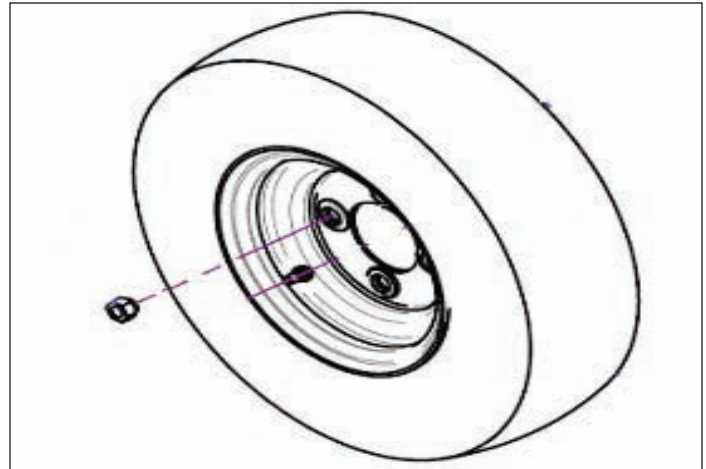


Figure 7-1. Rear Wheel Assembly

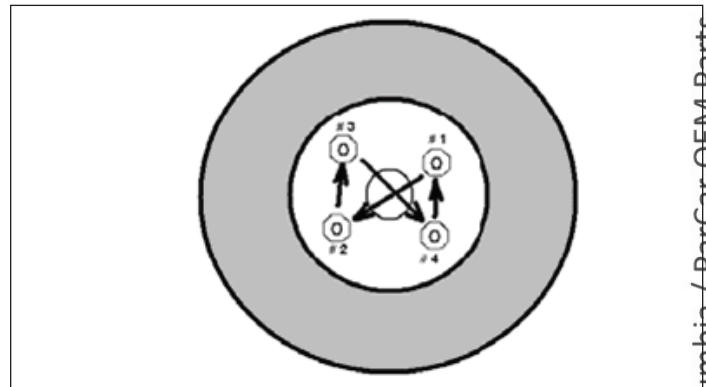


Figure 7-2. Criss-Cross Tightening Pattern

Columbia / ParCar OEM Parts  
evtechnicalservices.com

**Replacing Rear Shock Absorber**

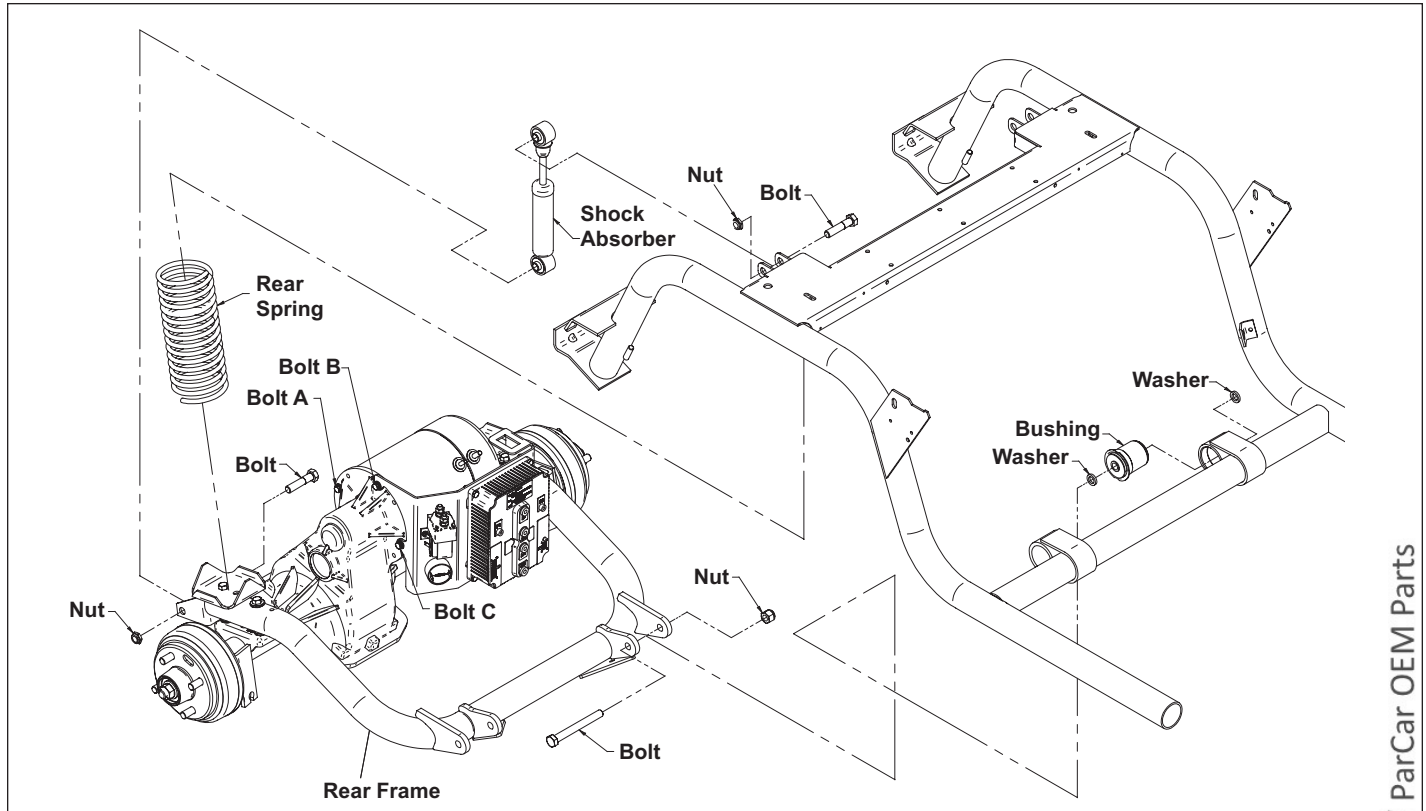
Replace shock absorber if dampening affect is not present when shock absorber is collapsed or extended, or there are signs of oil leakage.

1. Raise the rear body.
2. Remove upper and lower mounting bolts and nuts securing shock absorber (Figure 7-3).
3. Install new shock absorber and secure with mounting bolts and new nylock nuts. Torque to 45 ft. lbs. (61 Nm).
4. Lower the rear body.



**Replacing Rear Springs**

1. Place a hydraulic jack under the rear carrier assembly.
2. Remove rear shock absorbers as described above.
3. Slowly lower the rear carrier/axle assembly until springs can be removed (Figure 7-3).
4. Install new springs and raise rear carrier/axle assembly to seat the springs.
5. Reinstall shocks.



**Figure 7-3. Rear Suspension**

**Replacing Rear Frame Bushings**

1. Place a hydraulic jack under the rear frame assembly where it attaches to the frame.
2. Remove the two bolts, washers and nuts securing the rear frame to the frame (Figure 7-3).
3. Drive out the two bushings and replace with new bushings.
4. Reattach the rear frame assembly to the frame with two bolts, washers and nuts. Torque to 45 ft. lbs. (61 Nm).

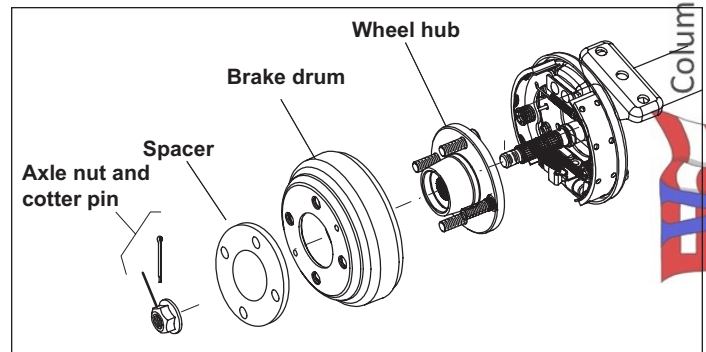
**REAR AXLE ASSEMBLY**

**⚠ WARNING**

To perform this service, raise vehicle using floor jack and safely support it with jack stands positioned under main frame tubes. See Section 3 - Lifting Instructions.

**Removing Rear Axle**

1. Before raising vehicle, with wheels on the ground, break loose the lug nuts (Figure 7-1).
2. Raise the vehicle and engage the brake.
- 3a. Mechanical Drum Brake: Remove lug nuts and remove rear wheel/tire assemblies. Remove and discard cotter pin and axle nut. Release brake and remove spacer and rear brake drum (Figure 7-4). Repeat for other side.



**Figure 7-4. Rear Mechanical Brake Drum and Hub**

- 3b. Hydraulic Drum Brake: Remove four Tinnerman nuts and remove rear wheel/tire assemblies. Release brake and remove brake drum.
4. Remove rear shock absorbers and springs as described on the previous page.
5. Remove the traction motor as described in Section 10-Traction Drive System. Remove U-bolt securing rear axle to traction drive motor mounting plate.
- 6a. Mechanical Drum Brake: See Figure 7-5. Remove cotter pins, clevis pins and e-rings. Disconnect brake cables from brake assemblies on the rear axle.

- 6b. Hydraulic Drum Brake: Disconnect hydraulic brake lines from brake assemblies on the rear axle.
7. Remove four nuts, bolts and washers securing rear axle to rear frame.

**▲CAUTION**

Rear axle is heavy and awkward to move. Get help lifting and removing axle to prevent possible personal injury.

**Disassembling Rear Axle**

**GENERAL INFORMATION**

The rear axle is a precision assembly and any repair or replacement of parts must be done with great care in a clean environment. Before attempting to perform any axle service, read and understand all the procedures in this section.

- Handle all gears with extreme care.
- The axle assembly should be degreased prior to disassembly.
- Dirt is an abrasive and will cause premature wear of bearings and other parts. A small wash tank for cleaning parts should be close by when disassembling the axle assembly.
- Use soft, clean, lint-free towels to dry components before cleaning.
- Parts should be cleaned with emulsion cleaners or petroleum based cleaners.

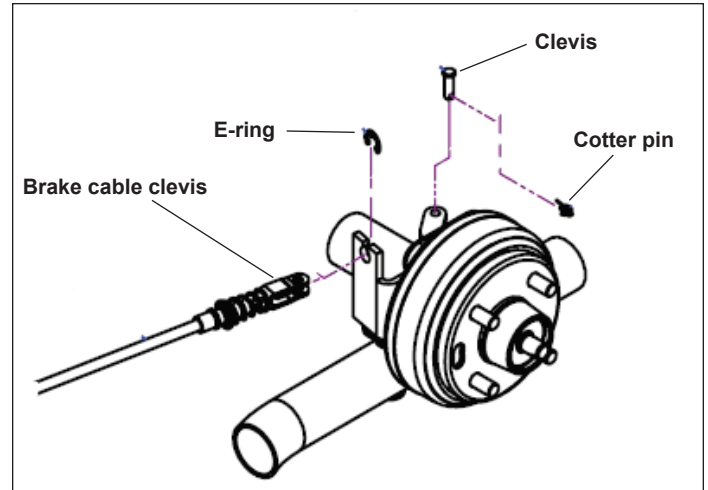
**▲DANGER**

**Do not use gasoline as a cleaner.**

**NOTICE**

**Bearings should not be dried by spinning with compressed air. This can damage mating surfaces due to lack of lubrication.**

- After drying, parts should be lightly coated with SAE 30 weight oil to prevent corrosion damage. If parts are to be stored for a prolonged period of time, they should be wrapped in newspaper and plastic.
- Bearings, seals and O-rings should be replaced with new parts whenever they are removed. Always wipe seals and O-rings with SAE 30 oil before installing.



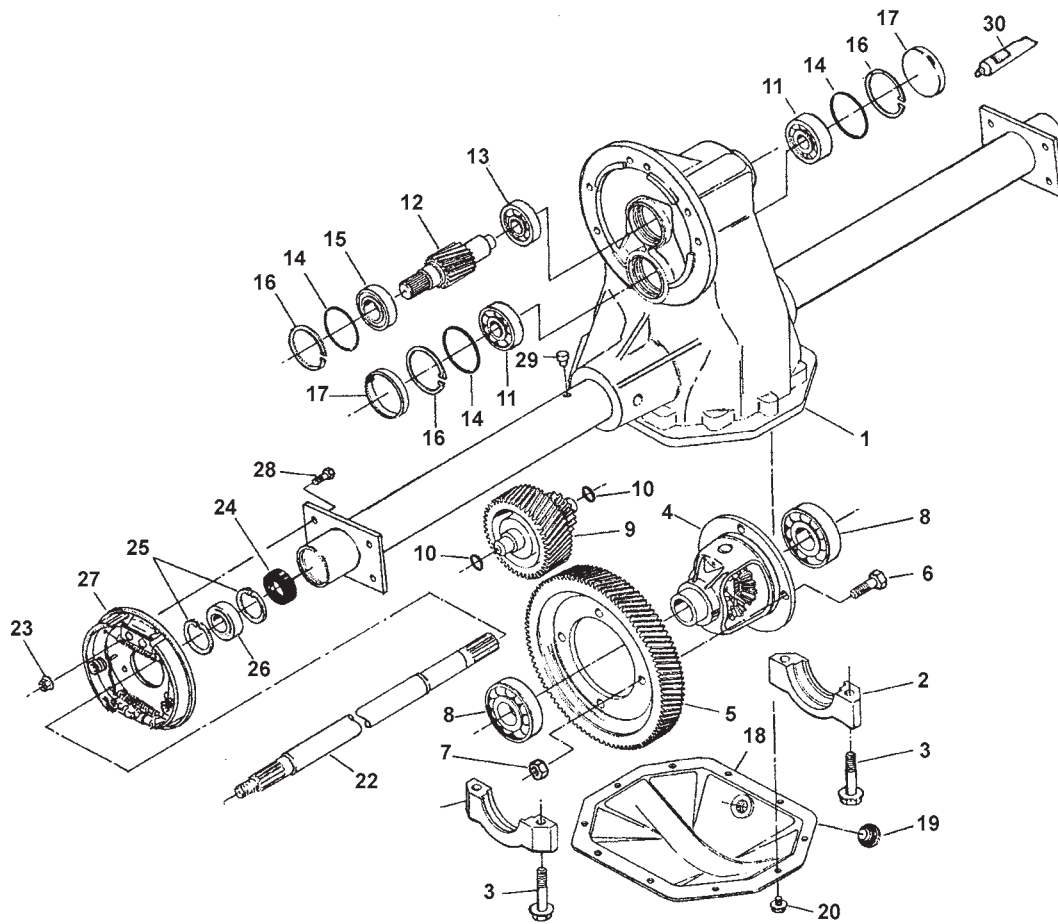
**Figure 7-5. Brake Cable Attaching Hardware**

- Snap rings must be removed/installed with care to prevent damage to bearings, seals and bearing bores.
- Remove all residual gasket material from sealing surfaces.
- Use soft, clean, lint-free towels to dry components before cleaning.
- Parts should be cleaned with emulsion cleaners or petroleum based cleaners. Inspect all parts for signs of wear or damage and replace if necessary.

**TORQUES**

Differential bearing cap	35-45 ft.lbs. (12-16 Nm)
Ring gear bolts	35-45 ft.lbs. (12-16 Nm)
Cover plate screws	16-24 ft.lbs. (6-9 Nm)
Fill plug	25-40 ft.lbs. (9-14 Nm)
Brake bolts - 160 mm brakes	15-19 ft.lbs. (5-7 Nm)
Spindle nut	95-115 ft. lbs. (34-41 Nm)

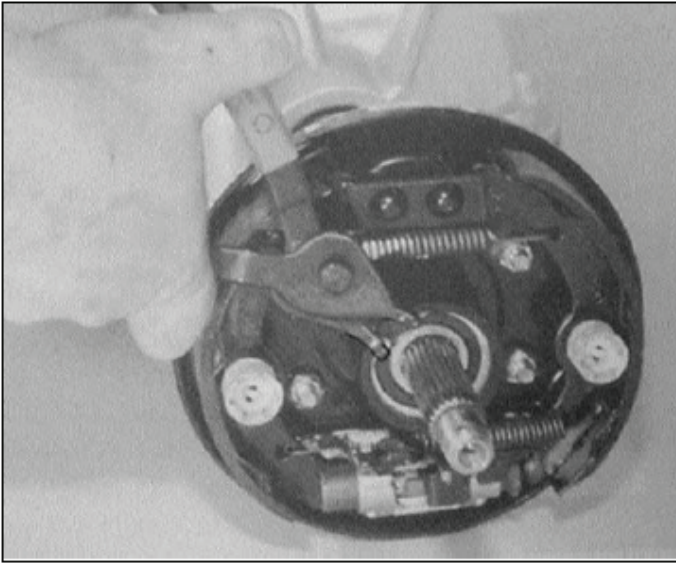
Columbia / ParCar OEM Parts  
evtechnicalservices.com  
TECHNICAL SERVICES



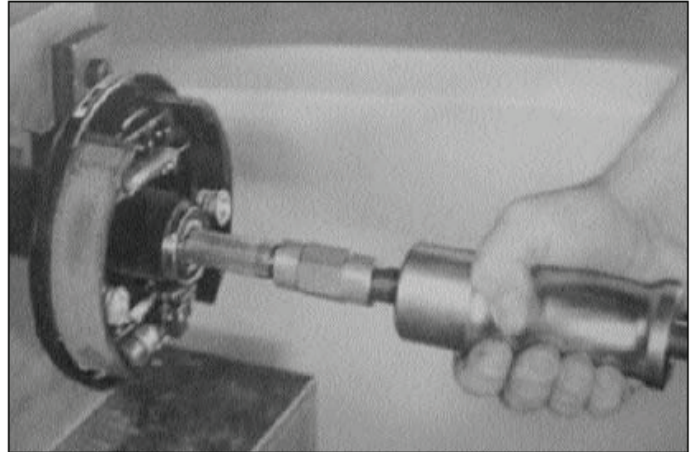
Item	Qty.	Description	Item	Qty.	Description	Item	Qty.	Description
1	1	Carrier Sub-Assy.	11	2	Bearing, ball	21	1	Sealant, anaerobic
2	2	Bearing cap	12	1	Input shaft	22	1	Axle shaft
3	4	Bolt, bearing cap	13	1	Bearing, ball	23	8	Nut, brake, 160mm
4	1	Diff. Case Assy.	14	3	O-ring	24	2	Oil seal
5	1	Gear, output	15	1	Bearing, ball	25	4	Snap ring
6	4	Cap screw	16	3	Snap ring	26	2	Bearing
7	4	Nut	17	2	Plug, cup	27	1	Brake Assy.
8	2	Bearing, ball	18	1	Cover, carrier	28	8	Bolt, brake, 160mm
9	1	Intermediate Shaft & Gear	19	1	Plug, fill	29	1	Vent
10	2	O-ring	20	10	Screw, cover plate			

**Figure 7-6. Rear Axle**

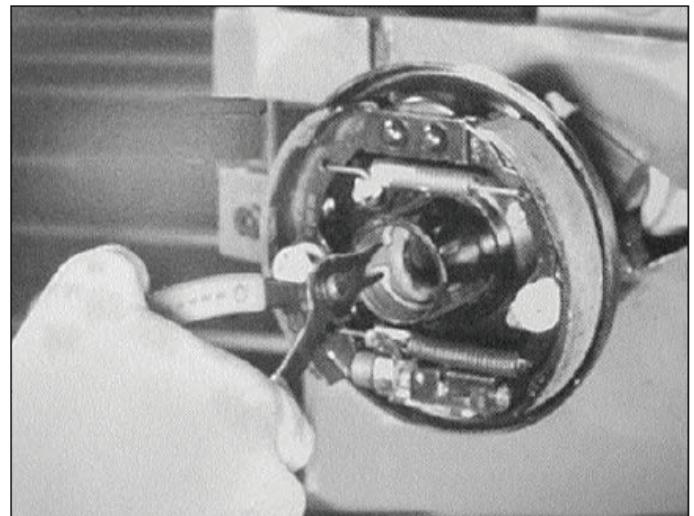




**Figure 7-7. Removing Outer Snap Ring**



**Figure 7-8. Removing Axle Shaft/Bearing Assembly**



**Figure 7-9. Removing Inner Snap Ring**

**DISASSEMBLING REAR AXLE**

**▲ DANGER**

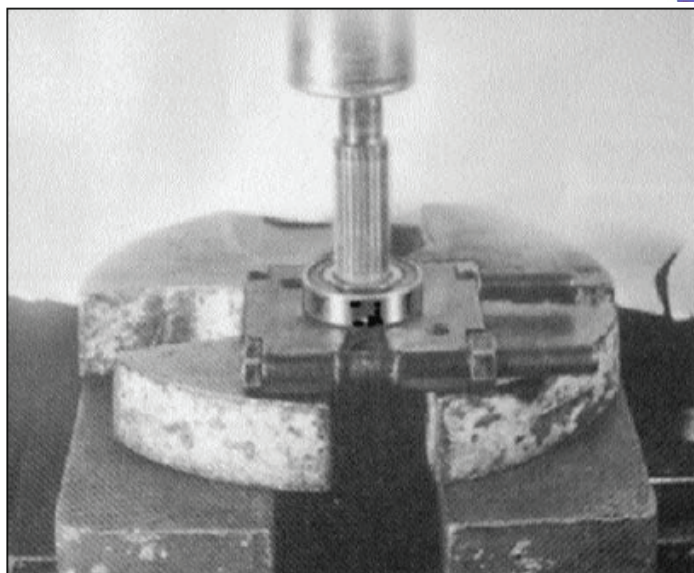
Safety glasses should be worn at all times when disassembling and assembling the axle.

All callout numbers in steps refer to Figure 7-6.

1. Remove outer snap ring (25). See Figure 7-7.
3. Using a slide hammer attached to the threaded end of the axle shaft (22), remove axle shaft and bearing (26) assembly. See Figure 7-8.
4. Remove inner snap ring (25). Use care to not damage bearing surfaces. See Figure 7-9.
5. Remove the bearing (26) from the axle shaft by supporting the inner race of the bearing in an arbor press. Apply pressure to the threaded end of the axle shaft. See Figure 7-10.
6. Repeat steps 1-5 to remove and disassemble the other shaft.
7. Remove ten cover screws (20).
8. Position the axle housing (1) over a drain pan. Using a putty knife, separate the cover plate from the housing (Figure 7-11). Use care to not damage the housing sealing surfaces or to deform the cover plate.
9. Remove four bearing cap bolts (3) and both bearing caps (2). See Figure 7-12.

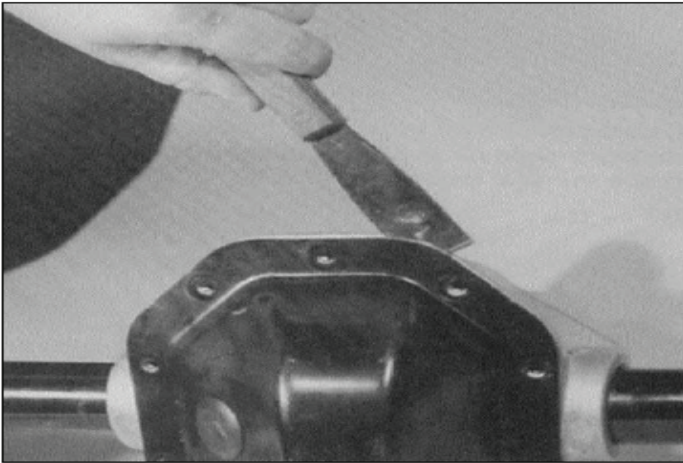
**NOTICE**

Bearing caps are marked for identification. Letters or numbers are stamped in horizontal and vertical position. When reassembling, install caps back in their original positions, using these stamps as a guide.

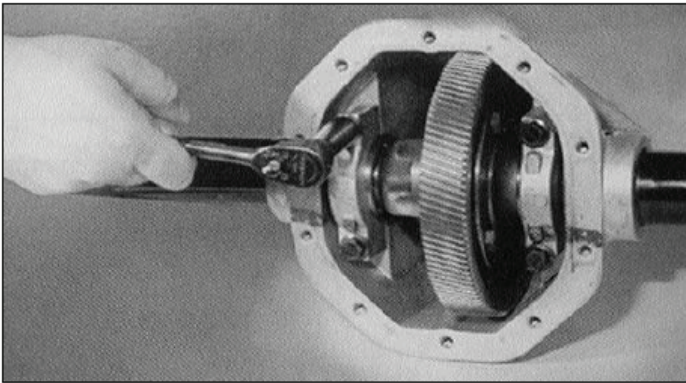


**Figure 7-10. Removing Axle Bearing**

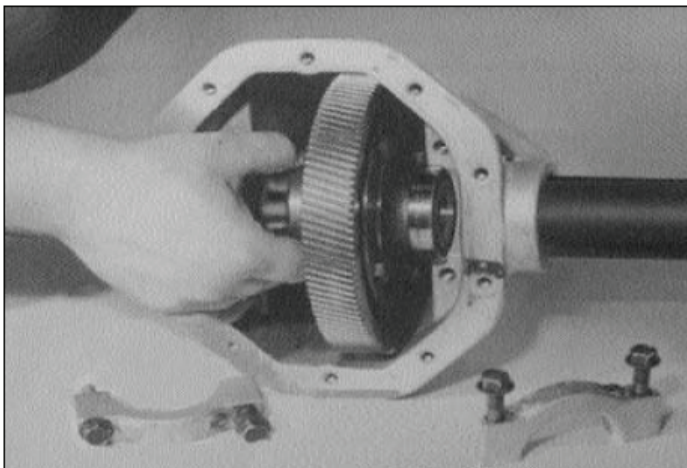




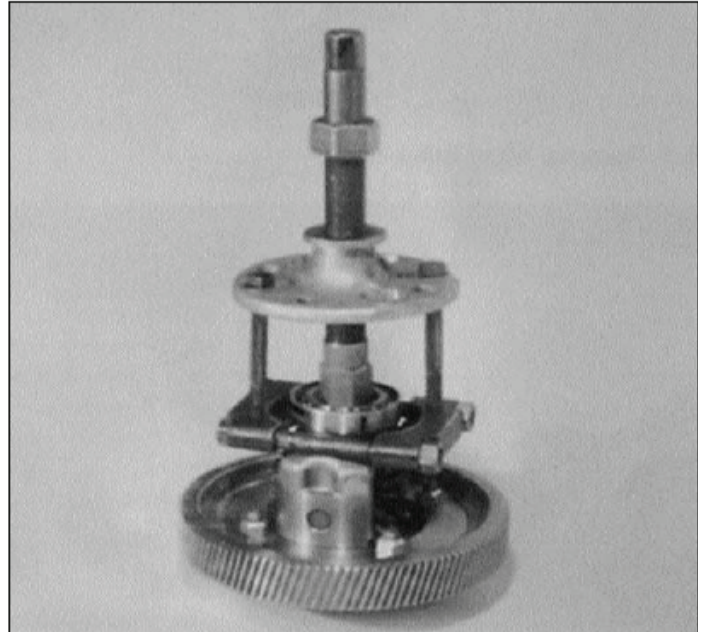
*Figure 7-11. Removing Cover Plate*



*Figure 7-12. Removing Bearing Caps*

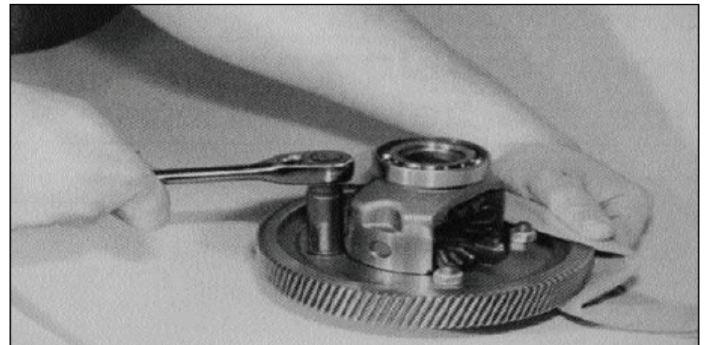


*Figure 7-13. Removing Differential Assembly*



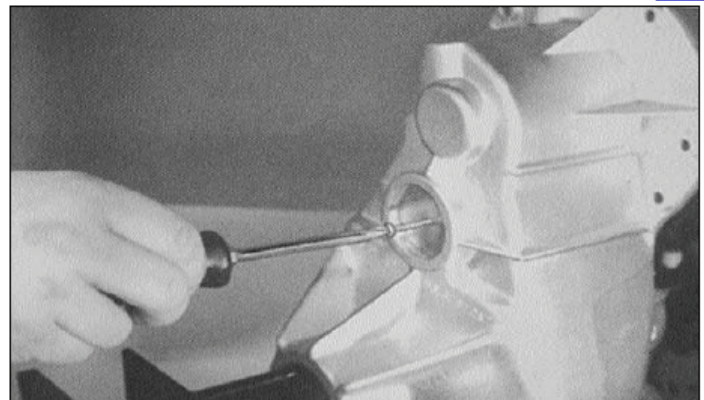
*Figure 7-14. Removing Differential Bearings*

OEI



*Figure 7-15. Removing Output Gear from Differential*

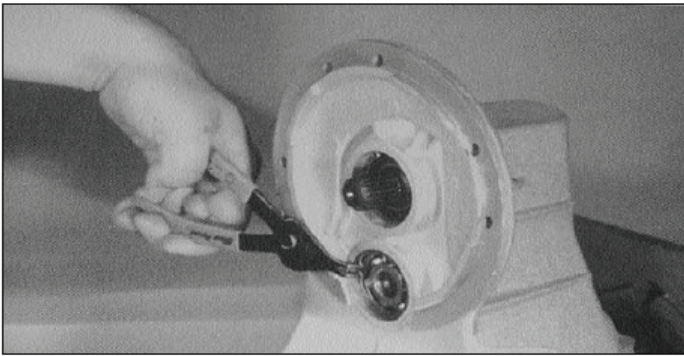
evtechnicalservices.com



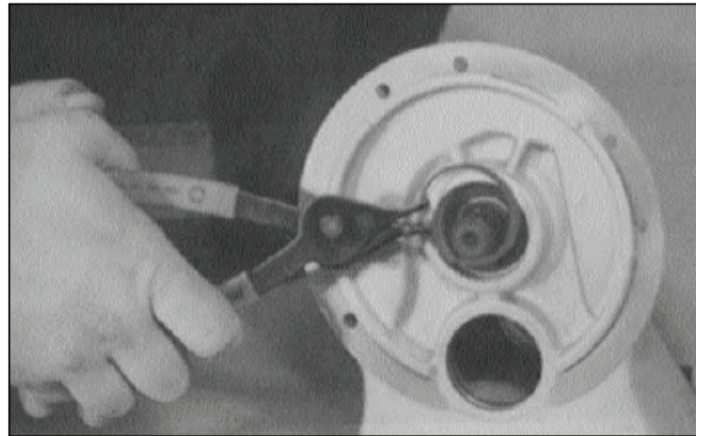
*Figure 7-16. Removing Cup Plugs*

10. Using a bearing puller, remove differential bearings (8) from each side of the differential case. See Figure 7-14.
11. Remove four bolts (6) and nuts (7) from the final drive output gear (5). Remove gear from differential case. Use care not to damage gear teeth. See Figure 7-15.

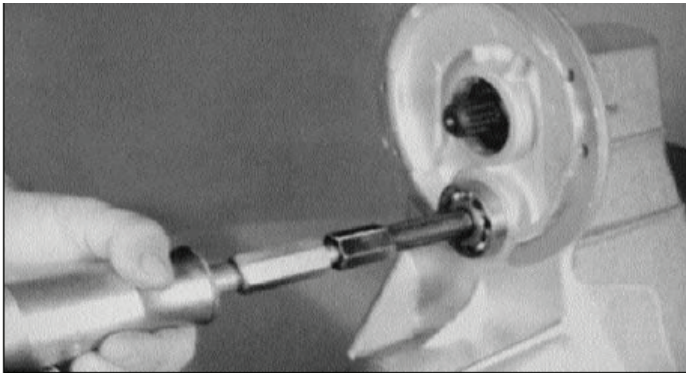




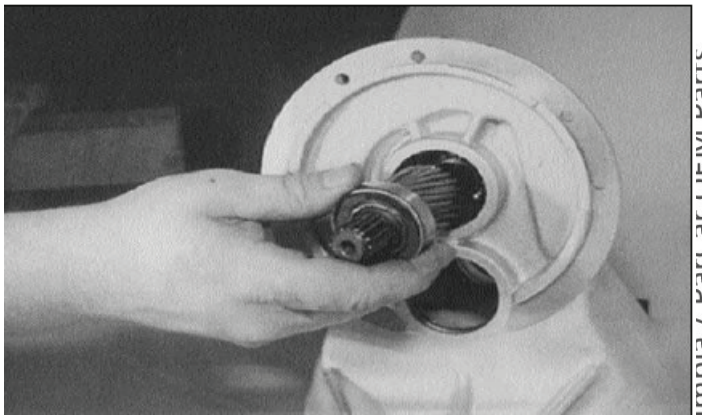
**Figure 7-17. Removing Snap Rings**



**Figure 7-19. Input Shaft Bore Snap Ring**



**Figure 7-18. Removing Intermediate Shaft**



**Figure 7-20. Intermediate Shaft & Bearing**

12. Punch or drill a 1/8" diameter hole near the center of each intermediate cup plug (17). Insert a suitably sized sheet metal screw until the metal bore plug is forced out of the bearing bore. See Figure 7-16.

13. Remove snap rings (16) from each intermediate bore. See Figure 7-17.

**NOTICE**

**Shaft and gear assembly must be supported by hand as not to damage gear teeth.**

**NOTICE**

**Small end of intermediate shaft and gear assembly must be tilted toward opening in bottom of housing for removal.**

14. Using a brass drift pin, drive the intermediate shaft (9) from the flange side of housing. Shaft should travel far enough to allow engagement of I.D. bearing puller.

15. Using an I.D. bearing puller attached to a slide hammer, remove intermediate bearing (11) from flange side of housing. See Figure 7-18.

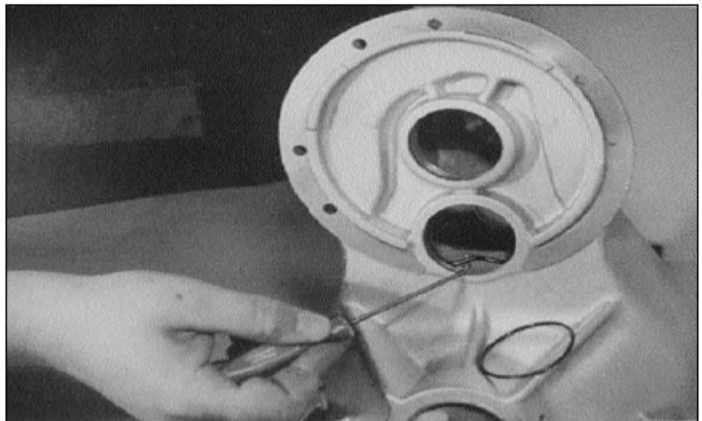
16. Repeat steps 1-15 for intermediate bearing on opposite side.

17. Remove snap ring (16) from input shaft bore (12). See Figure 7-19.

**NOTICE**

**Input shaft assembly must be supported by hand as not to damage gear teeth.**

18. Pull input shaft assembly (12) from housing. The input shaft



**Figure 7-21. Removing O-rings**

assembly should slide out easily. If resistance is encountered, a slide hammer may be required. See Figure 7-20.

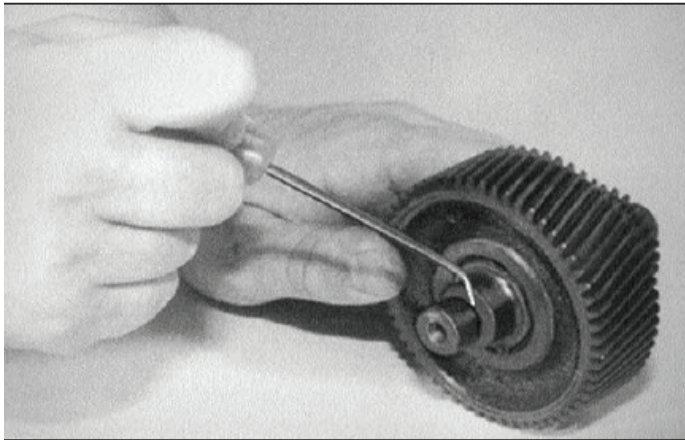
19. Remove O-rings from outer input bearing bore and both intermediate bores. See Figure 7-21.

20. Remove O-rings (10) at each end of intermediate shaft on bearing shoulders. See Figure 7-22.

Columbia / ParCar OEM Parts  
evtechnicalservices.com







**Figure 7-22. Removing O-rings from Intermediate Shaft & Gear**

21. Clean the axle housing and carrier cover (18) with lint-free rags. Remove all traces of old silicone sealant from sealing surface of cover and housing.

**Assembling Rear Axle**

All callout numbers in steps refer to Figure 7-6.

1. Prior to installing, wipe new O-rings with SAE 30 weight oil. Install one O-ring (14) into outer input shaft (12) bearing bore. Install two O-rings (14) into intermediate shaft (9) bearing bores and two O-rings (10) onto intermediate shaft and gear assembly.
2. Press inner and outer bearings (13, 15) on input shaft (12) until seated against bearing shoulders. See Figure 7-23.
3. Install new O-ring (14) into bearing bore of input shaft (12).

**NOTICE**

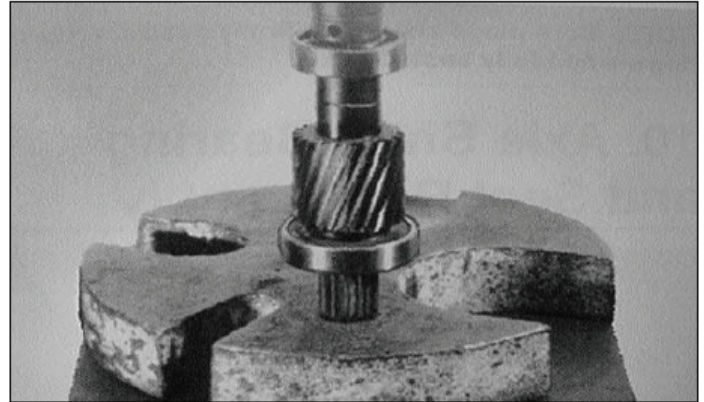
**Input shaft assembly must be supported by hand as not to damage gear teeth. Use care if using a hammer to coax shaft and gear into correct position. Use care if using a hammer to coax shaft and gear into correct position.**

4. Install input shaft (12). Bearings (13, 15) and shaft should slide easily into housing. If resistance is encountered, use a plastic or leather mallet to tap shaft into position. See Figure 7-20.
5. Install outer snap ring (16) at input shaft bore. See Figure 7-21.
6. After O-rings (10) are installed on shaft (9) and housing (1), install intermediate shaft and gear assembly (9) through bottom opening in housing.

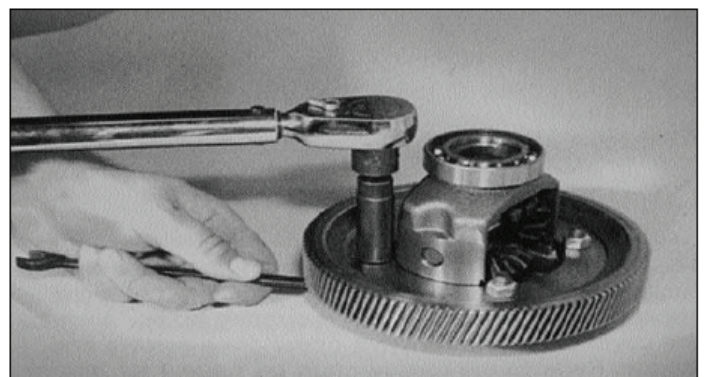
**NOTICE**

**Small end of intermediate shaft and gear assembly must be tilted toward bottom opening until bearing trunnion visually engages intermediate bores.**

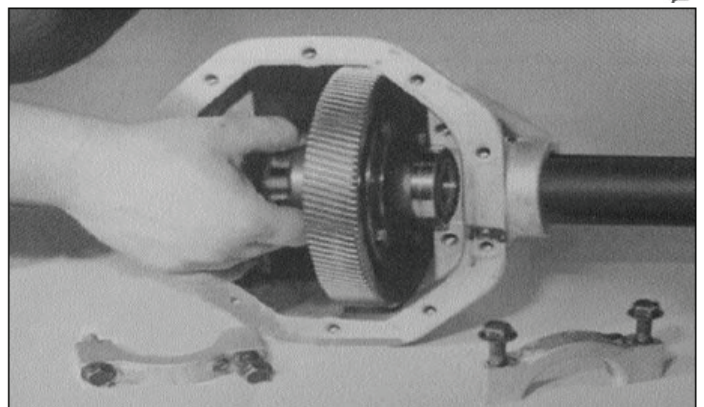
7. Align both bearing trunnions with intermediate bore. Continue supporting intermediate shaft and gear assembly with one hand and insert the flanged side bearing (11) into opening.



**Figure 7-23. Installing Bearings on Input Shaft**



**Figure 7-24. Torquing Differential Case Nuts**



**Figure 7-25. Installing Differential Case Assembly**

To seat the bearing past the O-ring, a leather or plastic mallet may be required.

**NOTICE**

**Intermediate shaft assembly must be supported by hand as not to damage gear teeth. Use care if using a hammer to coax shaft and gear into correct position.**

8. After flanged side bearing is seated past snap ring groove, install snap ring (16). Repeat procedure for opposite side bearing and snap ring.

9. Position differential case assembly (4) with flanged side trunnion face down on work surface. Align output gear (5) mounting holes with differential case. Install four bolts (6) and nuts (7). Bolts should be installed from differential flange side. Torque nuts to 35-45 ft. lbs. (47-61 Nm). See Figure 7-24.
10. Differential bearings (8) can be installed on differential case (4) before or after installing ring gear. Use care not to damage differential bearings or final gear (5) when installing the opposite component.
11. Position housing (1) with opening facing up. Insert differential case, output gear (5) and bearing (8) assembly into housing. Make sure teeth of gear (5) mesh with teeth of small gear on intermediate shaft (9) and that both turn freely. See Figure 7-25.

**NOTICE**

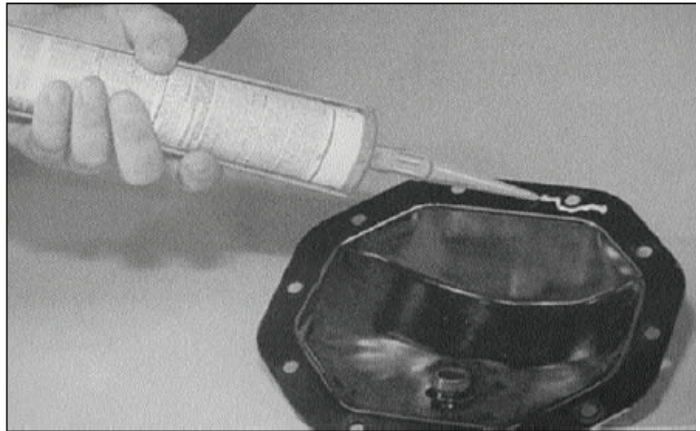
**Bearing caps are marked for identification. Letters or numbers are stamped in horizontal and vertical position. When reassembling, install caps back in their original positions, using these stamps as a guide.**

12. Install differential bearing caps (2) with bolts (3). Torque bolts to 35-45 ft. lbs. (47-61 Nm).
13. Place a small bead of RTV (non-acidic) silicone sealant to flange of cover plate (18). Sealant should be applied to inside of cover plate mounting holes (Figure 7-26).
14. Install cover plate (18) with ten bolts (20). Torque bolts to 16-24 ft. lbs. (21.5-32.5 Nm).
15. Install new intermediate cup plug (17) to both sides of housing (1). Use Loctite Safety Solvent #75559 to clean bores, then apply Loctite RC 609 to housing bores. Cup plugs can be installed by using a properly sized driver and hammer. Cup plugs should be firmly seated against snap rings (16). See Figure 7-27.
16. With properly sized seal driver, install shaft oil seals (24). Press seals to depth of 1.125" (28.5 m). See Figure 7-28.
17. Install inner snap ring (25) to both right and left tubes. See Figure 7-29).
18. Press bearings (26) onto axle shafts (22). Bearing should seat on shoulder. Use appropriate driver to install bearings. See Figure 7-30.
19. Coat lip of seal (24) with SAE 30 oil before inserting axle shaft (22). Insert axle shaft assemblies into tubes. Using a properly sized bearing driver, tap axle shaft assembly until it is seated firmly against inner snap ring (25).

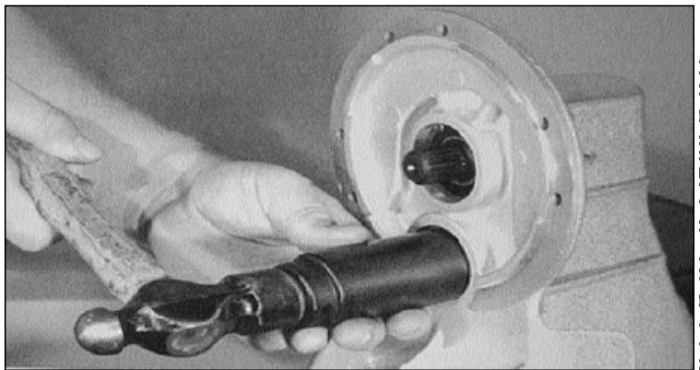
Shaft may have to be rotated to engage differential splines during installation.

20. Install outer snap ring (25) in each tube (Figure 7-31).
21. Remove fill plug (19) in cover plate (18). Fill axle assembly with 12 ounces (360 ml) of Light Weight Gear Lubricant, SAE 30.

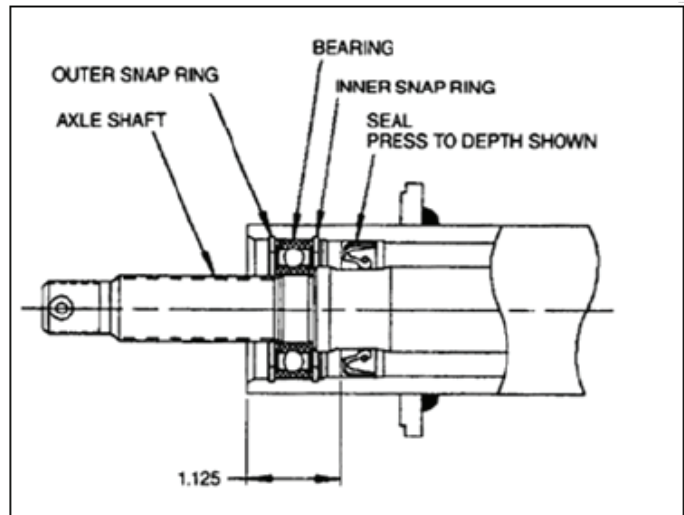
Install fill plug. If it is a threaded plug, torque to 25-40 ft. lbs. (6-14 Nm).



*Figure 7-26. Installing Differential Case Assembly*

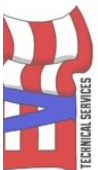


*Figure 7-27. Installing Cup Plugs*

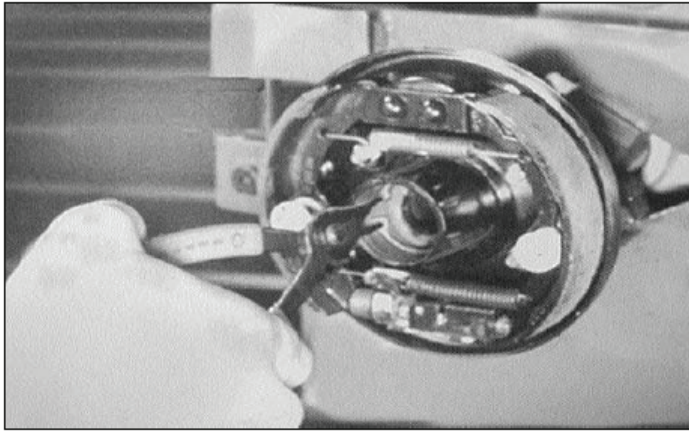


*Figure 7-28. Axle Components*

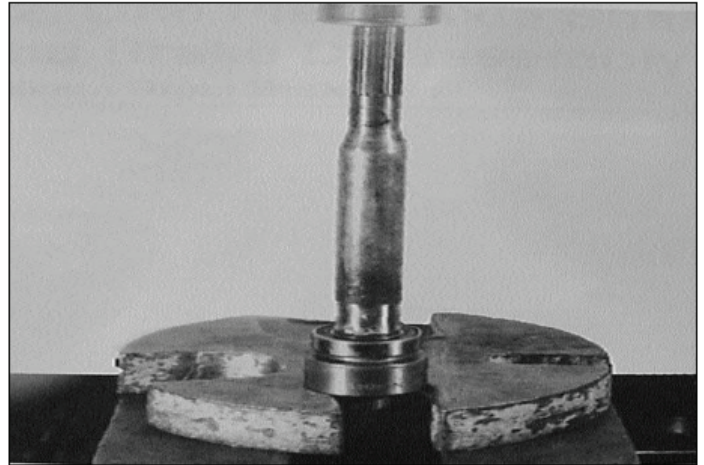
Columbia / Fair Cat / EELV / Fair US  
evtechnicalservices.com







**Figure 7-29. Installing Inner Snap Ring**



**Figure 7-30. Installing Bearings on Axle Shaft**

22. Apply Anti-Seize compound to the splines before installing the drum/hub.

### Installing Rear Axle

#### ▲CAUTION

Rear axle is heavy and awkward to move. Get help lifting and installing axle to prevent possible personal injury.

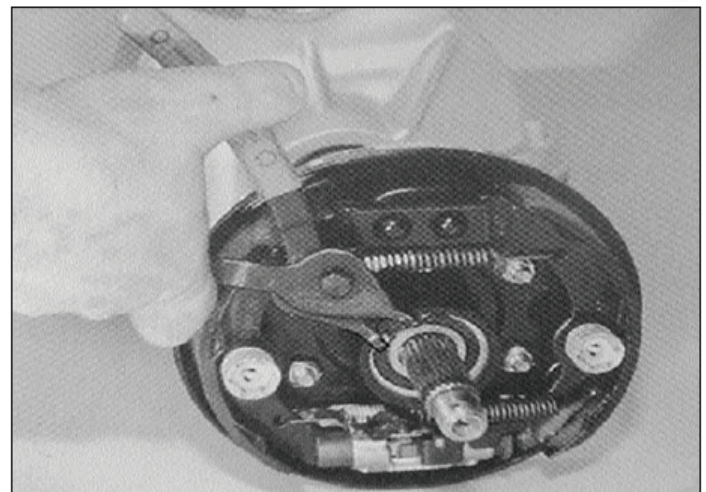
#### NOTICE

Make sure rear axle has oil in the differential before installing. See *Checking Differential Oil* in this section before installing.

1. Carefully position axle into place.
2. Secure axle to frame with four bolts, washers and nuts. Torque nuts to 45 ft. lbs. (16 Nm).
- 3a. Mechanical Drum Brake: See Figure 7-5. Connect brake cables to brake assemblies using new cotter pins, clevis pins and e-rings.
- 3b. Hydraulic Drum Brake: Connect hydraulic brake lines to brake assemblies on the rear axle.

*NOTE: After installation is complete, bleed the hydraulic brake system. See Section 5-Accelerator & Brake System.*

4. Install U-bolt securing rear axle to traction drive motor mounting plate.
5. Install the traction motor as described in *Section 10-Traction Drive System*.
6. Install rear shock absorbers and springs as described previously in this section.



**Figure 7-31. Installing Outer Snap Ring**

- 6a. Mechanical Drum Brake: Install new axle nut. Engage brake and tighten axle nut to a minimum 65 ft. lbs. (62 Nm). Install new cotter pin. Install spacer and rear brake drum (Figure 7-4). Repeat for other side.
- 6b. Hydraulic Drum Brake: Install brake drum.
7. Install wheel assemblies as described previously in this section.
8. Drive the vehicle and test axle operation.





## REAR AXLE DIFFERENTIAL OIL

### Changing Differential Oil

Differential oil must be changed at least once a year under normal vehicle usage. If vehicle is operated under extreme conditions, or for more than 8 hours a day, oil should be changed twice a year.

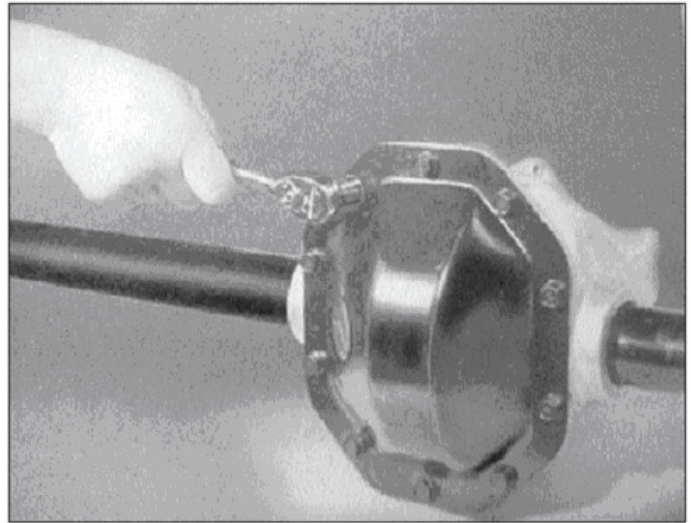
It is not necessary to remove the axle to change the differential oil.

#### **▲ WARNING**

**To perform this service, raise vehicle using floor jack and safely support it with jack stands positioned under main frame tubes. See Section 3 - Lifting Instructions.**

Have an oil drain pan handy.

1. Remove ten cover plate bolts (Figure 7-32).
2. Remove cover and drain oil into drain pan.
3. Clean carrier cover with lint-free rag.
4. Place a small bead of RTV (non-acidic) silicone sealant to flange of cover plate (18). Sealant should be applied to inside of cover plate mounting holes (Figure 7-26).
5. Install cover plate (18) with ten bolts (20). Torque bolts to 16-24 ft. lbs. (21.5-32.5 Nm).
6. Remove fill plug (19) in cover plate (18). Fill axle assembly with 12 ounces (360 ml) of Light Weight Gear Lubricant, SAE 30.
7. Install drain/fill plug. Torque to 25-40 ft. lbs. (6-14 Nm).



**Figure 7-32. Carrier Cover**

FRONT BODY.....	8-2
REPLACING FRONT HEADLIGHT BULB .....	8-2
REPLACING FRONT TURN SIGNAL BULB .....	8-2
FRONT BUMPER.....	8-3
BACK RESTS AND FRAME.....	8-3
SEAT CUSHION AND HANDRAILS.....	8-4
CENTER BODY .....	8-4
BAG RACK .....	8-5
TAIL LIGHTS AND REAR TURN SIGNALS.....	8-5
REAR BODY .....	8-6
REAR BUMPER.....	8-6
CONSOLE CONTROLS.....	8-6
Replacing Power On Off Key Switch .....	8-6
Replacing Directional Key switch.....	8-7
Replacing Head Light Switch .....	8-7
Replacing Battery Discharge Indicator (BDI).....	8-7
STEERING WHEEL .....	8-7
HORN .....	8-8
TURN SIGNAL / EMERGENCY FLASHER CONTROL .....	8-8

Columbia ParCar EIM Parts  
 evtechnicalservices.com  


## ELECTRIC VEHICLE SERVICE

When servicing the electric vehicle always observe the following:

### SAFETY FIRST

**Always turn Power key to OFF, Directional key switch to Neutral, remove Power key, block tires and disconnect the battery negative (-) cable before performing any vehicle service to avoid accidental startup of vehicle and possible personal injury.**

*NOTE: Body sections can be refinished using standard automotive paints and flexible additives. Repair of cuts, scrapes and gouges can be accomplished using flexible bumper repair materials. See your local body and paint supply experts for specific recommendations for materials and procedures.*

## FRONT BODY

### Removing Front Body

1. Remove the front nameplate (if attached).
2. Remove the center bolt, washer and locknut from the front body (Figure 8-1).
3. The upper and side sections of the front body are attached to the cowl with ridged tabs extended into slots in the cowl. Push in on the body near the left or right side and pull the tab free of the slot. Repeat around the upper edge of the body until all tabs are free.
4. Lift body from cowl.
5. Disconnect the headlight wiring connectors (Figure 8-2).

*NOTE: It may be necessary to cut the cable tie securing the headlight wiring in order to unplug the connector.*

6. Remove the turn signal lamps by twisting and pulling them free of the front body.
7. Remove front body from vehicle.

### Installing Front Body

1. Position front body on vehicle.
2. Install turn signal bulbs into front body and twist 1/4 turn to fully seat them.
3. Reconnect headlight wiring connectors. Install a cable tie on the headlight wiring assembly if necessary.
4. Push front body tabs into cowl slots until fully seated.
5. Install bolt, washer and lock nut (Figure 8-1). Tighten securely.
6. Install new front nameplate.

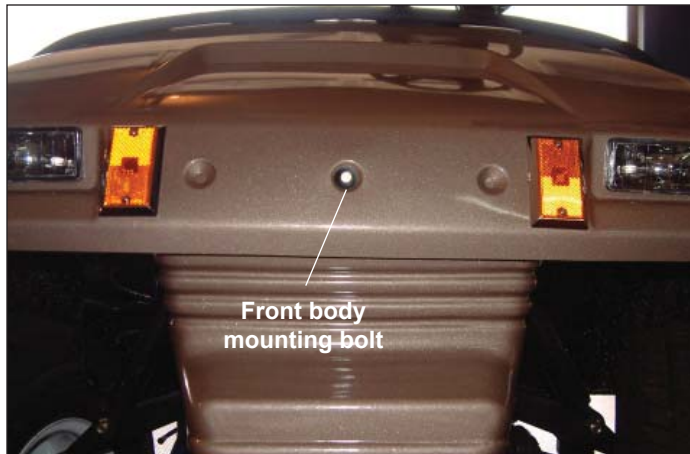


Figure 8-1. Front Body Center Mounting Hardware

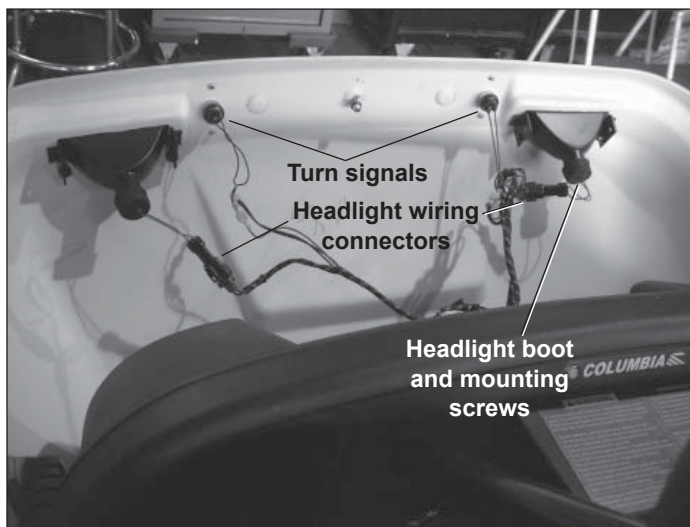


Figure 8-2. Headlight and Turn Signal Wiring Connections

## REPLACING FRONT HEADLIGHT BULB

1. Remove the front body.
2. Pull the rubber boot away from the headlight. Remove two screws securing bulb to headlight assembly (Figure 8-2).
3. Remove bulb and replace with new bulb.
4. Secure bulb assembly to headlight assembly with two screws and reinstall rubber boot.
5. Reinstall front body.

## REPLACING FRONT TURN SIGNAL BULB

*NOTE: It is not necessary to remove the front body to replace the turn signal bulbs.*

1. Remove the turn signal assembly by twisting 1/4 turn and pulling it free of the front body.
2. Replace old bulb with new bulb. Reinstall lamp assembly by inserting into body and twisting 1/4 turn until fully seated.

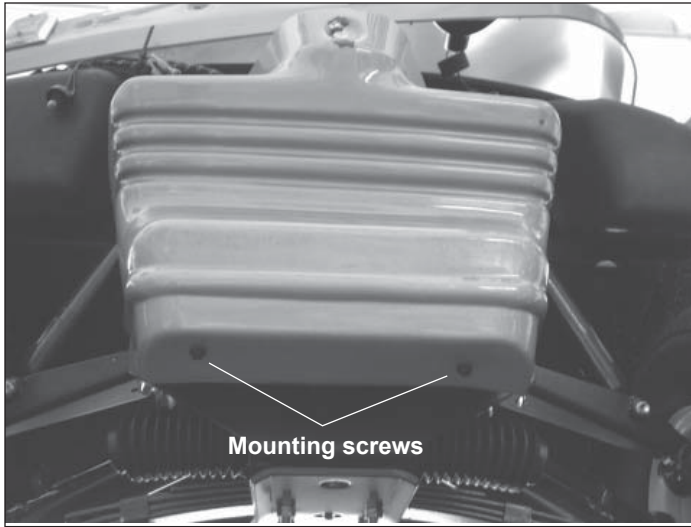


Figure 8-3. Front Bumper Bottom Mounting Screws

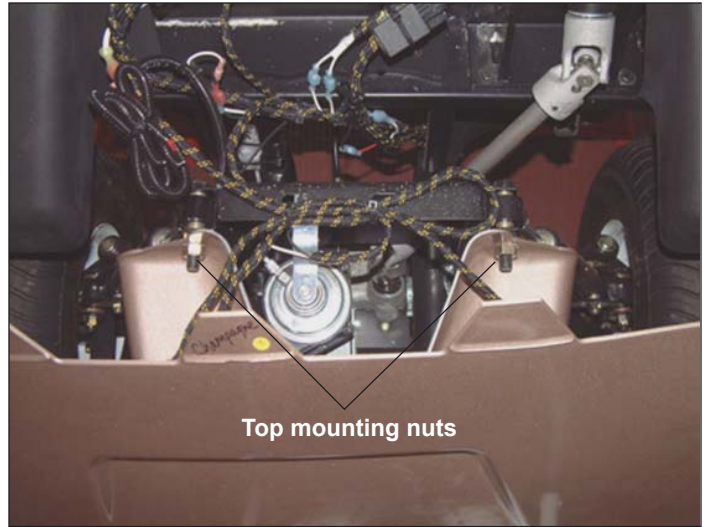


Figure 8-4. Front Bumper Top Mounting Nuts

## FRONT BUMPER

### Removing the Front Bumper

*NOTE: It is not necessary to remove the front body to remove the front bumper, but it will make it easier to access the two top mounting bolts. See Removing Front Body.*

1. Remove the two screws securing the bottom of the bumper to the frame (Figure 8-3).
2. Remove the two nuts securing the top of the bumper to the shock mounting bolts (Figure 8-4).

### Installing the Front Bumper

1. Fasten front bumper to front shock mounting bolts with nuts. Tighten securely.
2. Fasten front bumper to frame with two screws.
3. Reinstall front body if removed previously See *Installing Front Body*.

## BACK RESTS AND FRAME

### Removing the Back Rests and Frame

*NOTE: Only remove back rest frame if it is bent and requires replacement.*

1. Remove three mounting screws from each backrest.
2. Remove the cushions from the seat backs.
3. Remove four bolts, nuts and washers securing back rest frame to chassis frame.

### Installing the Back Rests

1. Install back rest frame to chassis frame using four bolts, nuts and washers.
2. Install the cushions and seat backs to seat back frame using three mounting bolts.

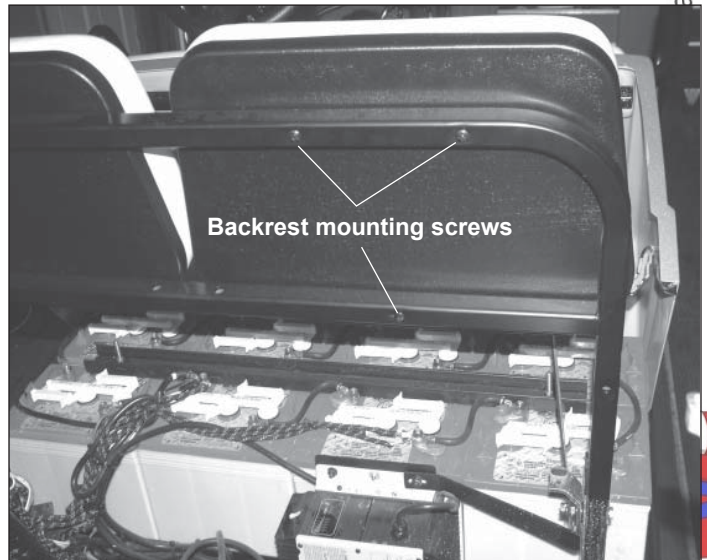


Figure 8-5. Backrest Mounting Screws

parts  
 evtechnicalservices.com  
 TECHNICAL SERVICES



## SEAT CUSHION AND HANDRAILS

### Removing Seat Cushion and Handrails

1. Raise center body to full upright position.
2. Remove four nuts, washers and studs securing seat cushion and hand rails to center body (Figure 8-6).
3. Remove seat cushion and two handrails.

### Installing Seat Cushion and Handrails

*NOTE: Installation is easier with two people performing the installation.*

1. Place handrails over mounting holes in top of center body . Place seat cushion on top of handrails with mounting holes aligned.
3. With one person holding seat cushion in place, carefully raise center body to full upright position.
4. Secure seat cushion and handrails to center body using three mounting studs, washers and nuts. Tighten nuts securely.

#### **▲ WARNING**

To avoid accident, injury or death, never operate vehicle without handrails in place.

## CENTER BODY

### Removing Center Body

*NOTE: It is not necessary to remove the seat cushion to remove the center body.*

1. Raise the center body and rear body to the full upright position.
3. Disconnect the power cord at the battery charger . If plug is taped, remove the electrical tape.
4. Cut all cable ties securing the power cord to wiring harness and batteries (Figure 8-7).
5. Remove nut securing power inlet plug to inside of middle body (Figure 8-8).
6. Remove locknut and washer securing restraint strap from middle body (Figure 8-9).
7. Remove middle body from chassis.

### Installing Center Body

1. Place center body on chassis with hinges located in the chassis floor slots.
2. Raise center body and secure restraint strap to mounting bolt with washer and locknut (Figure 8-9). Tighten locknut.
3. Route the power cord through the hole in the body and secure power cord plug with locknut (Figure 8-8).
4. Route the power cord along side the batteries and plug into the battery charger . Wrap plug with electrical tape. Secure power cord to wiring harness and batteries with new cable ties (Figure 8-7).

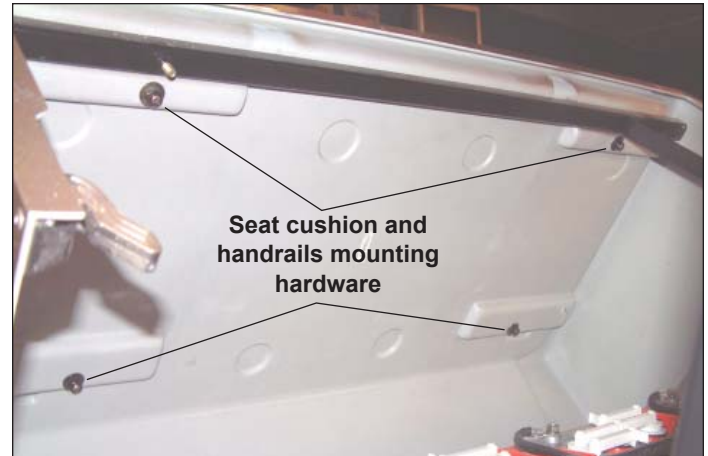


Figure 8-6. Seat Cushion and Handrails Mounting

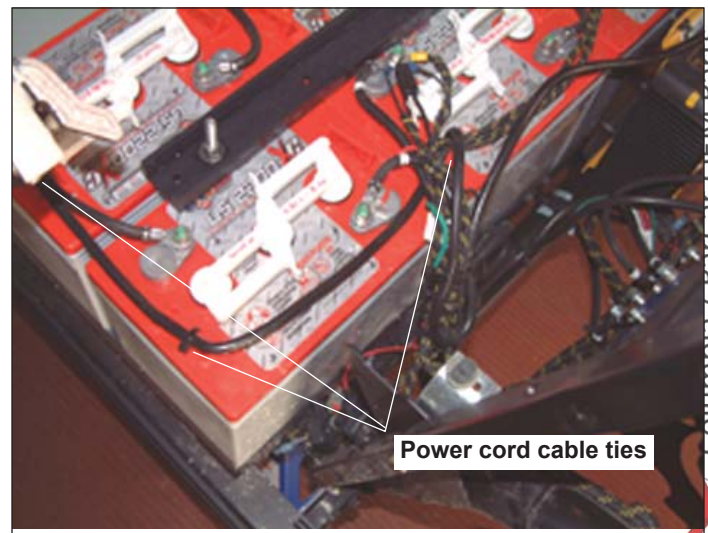


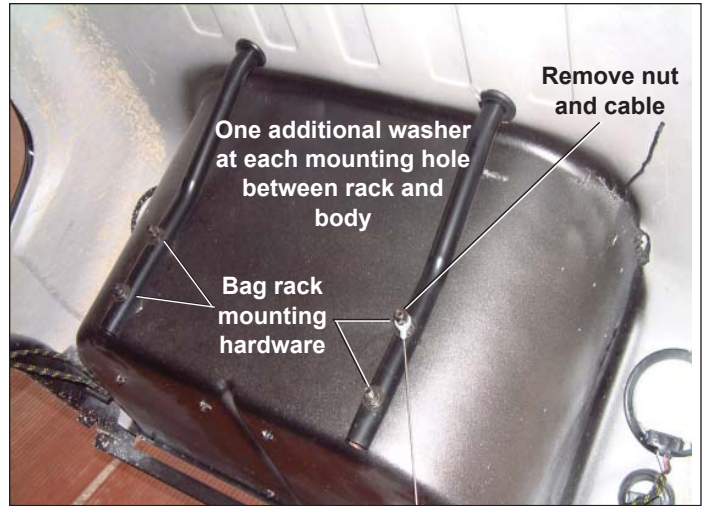
Figure 8-7. Power Cord



Figure 8-8. Power Inlet Plug



**Figure 8-9. Middle Body Strap Mounting**



**Figure 8-10. Bag Rack Mounting**

## BAG RACK

### Removing Bag Rack

1. Raise rear body to the full upright position.
2. Remove nut and restraint cable from mounting stud (Figure 8-10).
3. Carefully lay body all the way back. Remove remaining four bolts washers and nuts. There is also one washer between bag rack and body at each mounting hole.
4. Hold the rear body in an upright position, and using a rubber or rawhide mallet, carefully tap the bag rack out towards the rear and remove it from the rear body.

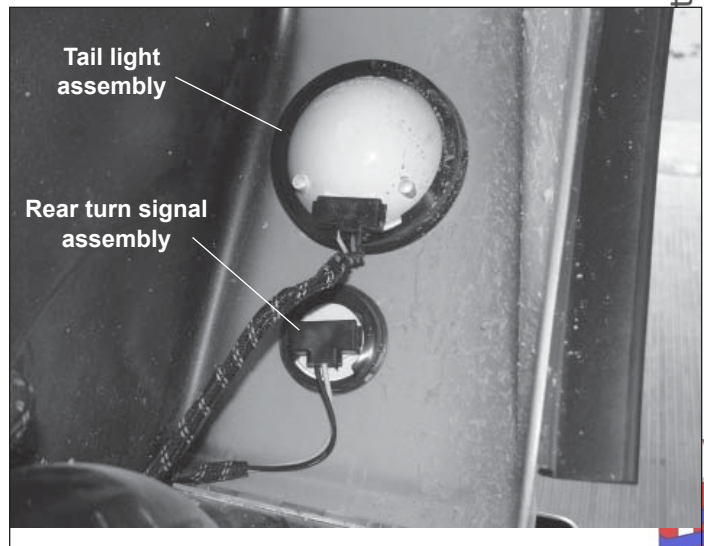
## TAIL LIGHTS AND REAR TURN SIGNALS

### Removing Tail Light or Rear Turn Signal

1. Raise rear body to the full upright position.
2. Unplug wiring harness at light or turn signal (Figure 8-11).
3. From inside the body, push the light or turn signal out of the rubber housing.
4. If rubber housing is damaged or worn, remove it from the body for replacement.

### Installing Tail Light or Rear Turn Signal

1. If rubber housing was removed, install new housing by pushing it into the hole, Position the wiring connector notch at the bottom.
2. Install new light or turn signal into rubber housing, pressing into the housing from outside the body. Be sure to align wire connector inlet with notch on rubber housing.
3. Reconnect wiring harness.



**Figure 8-11. Tail Light and Turn Signal**



**REAR BODY**

**Removing Rear Body**

1. Raise the center body to the full upright position.
2. Raise rear body to the full upright position.
3. Disconnect the wiring connectors from both tail lights and turn signals (Figure 8-11).
4. Remove nut and restraint cable from mounting stud (Figure 8-10).
5. Lower the body to the fully closed position.
6. From underneath the vehicle, remove the four nuts, washers, lockwashers, bolts and backing plates securing the body to the two rear hinges (Figure 8-12).
7. Carefully lift body off the chassis.



**Figure 8-12. Rear Body Hinge Mounting**

**Installing Rear Body**

1. Raise the center body to the full upright position.
2. Carefully place rear body on chassis. Make sure body guides sit securely on chassis supports (Figure 8-13).
3. With rear body in closed position, align a backing plate with left outside hinge holes on body and insert two bolts through backing plate, body and hinge. Secure with washers, lockwashers and nuts and tighten securely. Repeat for other hinge.
4. Carefully raise rear body to full upright position. Install restraint cable to bag rack mounting stud and secure with nut (Figure 8-10).
5. Install wiring connectors to the respective tail lights and turn signals.
6. Lower rear body.



**Figure 8-13. Rear Body Guide**

**REAR BUMPER**

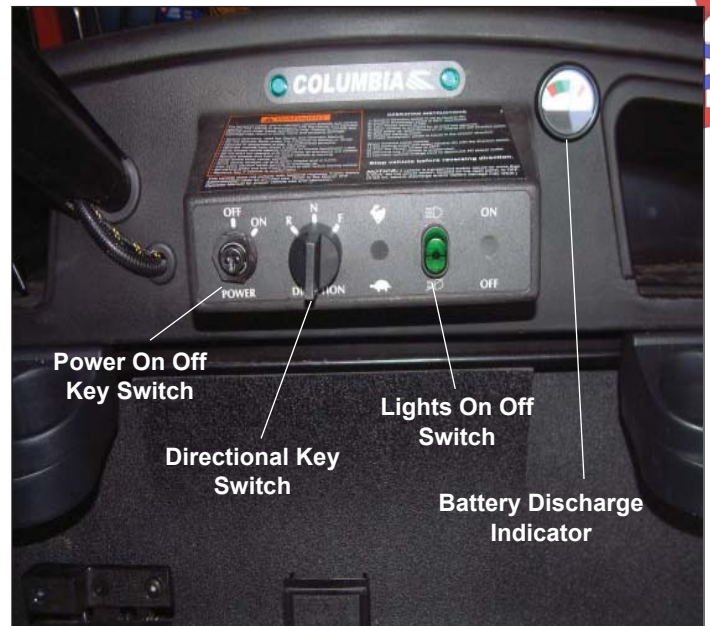
1. Remove two bolts, washers and locknuts securing bumper to chassis (Figure 8-12) and remove bumper.
2. Install rear bumper with two bolts and tighten securely.

**CONSOLE CONTROLS**

*NOTE: To replace any of the console controls, it is necessary to remove the front body to access the wiring. See Removing Front Body earlier in this section.*

**Replacing Power On Off Key Switch**

1. Remove nut and lockwasher securing key switch to front of console.
2. Push the switch out of the console towards the front of the vehicle.
3. Disconnect wiring and reconnect to new switch.
4. Install switch into console and secure with lockwasher and nut. Make sure key slot is vertical and at side of nut faces the console.



**Figure 8-14. Console Controls**

Columbia / ParCar OEM Parts  
evtechnicalservices.com  
TECHNICAL SERVICES

**Replacing Directional Key Switch**

*NOTE: The directional key is non-removeable. If the switch is inoperable, it is necessary to break the key off the switch to remove it.*

1. Break key to remove it from the key switch.
2. Remove nut and lockwasher securing key switch to front of console.
3. Push the switch out of the console towards the front of the vehicle.
4. Disconnect wiring and reconnect to new switch.
5. Install switch into console and secure with lockwasher and nut. Make sure key slot is vertical and at side of nut faces the console.
6. Install the directional key into the switch housing.

**Replacing Headlight Switch**

1. Remove plastic nut from back side of switch.
2. Disconnect wires from switch and remove switch from console.
3. Connect wires to new switch, place switch into console and secure with plastic nut.

**Replacing Battery Discharge Indicator (BDI)**

1. Remove two nuts securing wires to BDI.
2. Remove two nuts and bracket securing BDI to console.
3. Pull BDI from console. Install new BDI to console with bracket and two nuts.
4. Connect wires to BDI with two nuts.

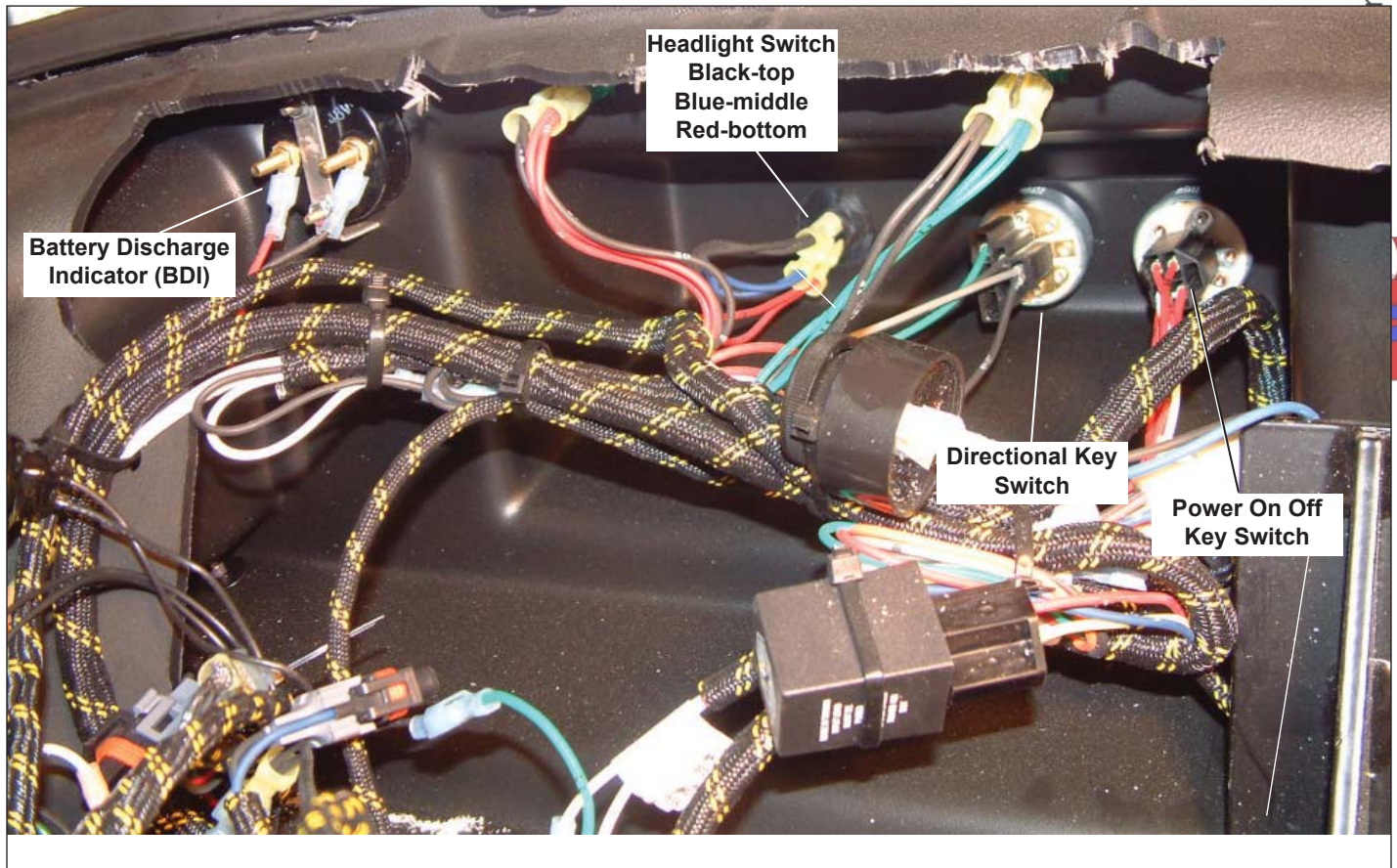
**STEERING WHEEL**

**Removing Steering Wheel**

1. Remove steering wheel cover by carefully prying out from steering wheel.
2. Remove Phillips head screws securing steering wheel to collar (Figure 8-16).
3. Remove steering wheel nut from center of steering wheel.
4. Pull steering wheel from spined shaft.

**Installing Steering Wheel**

1. Make sure wheels are pointed straight ahead. Install steering wheel on splined shaft.
2. Install steering wheel nut and tighten securely.
3. Connect collar to steering wheel with Phillips head screws.



**Figure 8-15. Console Controls Wiring and Mounting**

[evtechnicalservices.com](http://www.evtechnicalservices.com)  
 Car OEM Parts  
 TECHNICAL SERVICES



## HORN

### Replacing Horn Button

1. Pull the steering column cover away from the column to expose the wiring and horn mounting hardware (Figure 8-16).
2. Remove the horn button mounting hardware and disconnect the wires from the horn button.
3. Connect wires to new horn button and mount button to cover with original hardware.
4. Slide cover over steering wheel column and wiring then push into place on the column.

### Replacing Horn

1. Remove front body as described on page 8-2.
2. Disconnect wiring from horn (Figure 8-17).
3. Remove screw and horn from bracket.
4. Install new horn to bracket and connect wiring to horn.

## TURN SIGNAL / EMERGENCY FLASH CONTROL

### Disassembling Control

1. Remove two Phillips head screws securing control assembly to mounting bracket on steering column (Figure 8-18).
2. Remove two Phillips head screws securing top cover to control assembly.

*NOTE: The turn signal lever has a spring washer located underneath and is held in place by the cover. Turn signal lever can come off when cover is removed. Be careful not to lose the spring washer.*

3. Gently pry up on the two retaining brackets (Figure 8-19) and remove old bulb.
4. Install new bulb and push down until retaining brackets seat on housing.
4. Reinstall front cover with two Phillips head screws.
5. Remove two Phillips head screws securing back cover and remove cover to expose wiring (Figure 8-20).
6. Remove retaining screw (Figure 8-22) and pull assembly out of housing to expose contacts. Clean contacts if required or replace if badly pitted or damaged.

### Assembling Control

1. If contact assembly was removed, reinstall and secure with retaining screw (Figure 8-20).
2. Install cover with two Phillips head screws.
3. Coat the inside of turn signal assembly with lithium grease and install front cover with two Phillips head screws.
4. Secure control assembly to mounting bracket on steering column with two Phillips head screws.



Figure 8-16. Horn Button



Figure 8-17. Horn Mounting

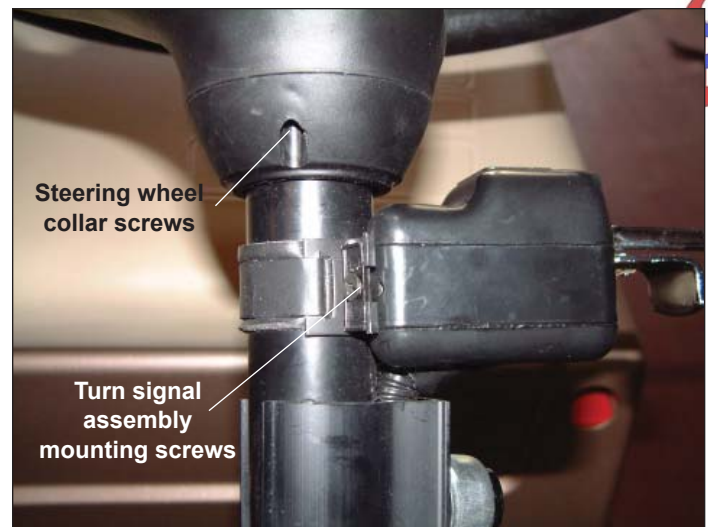
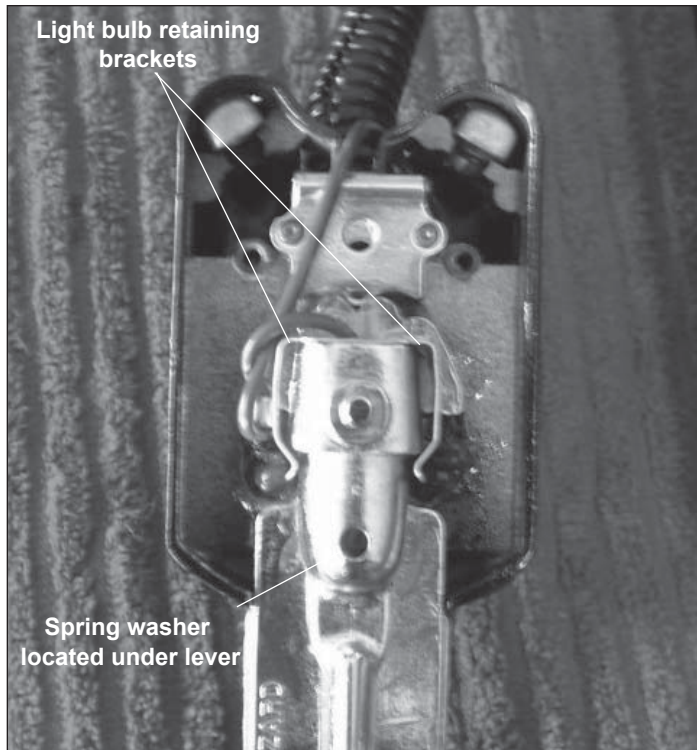
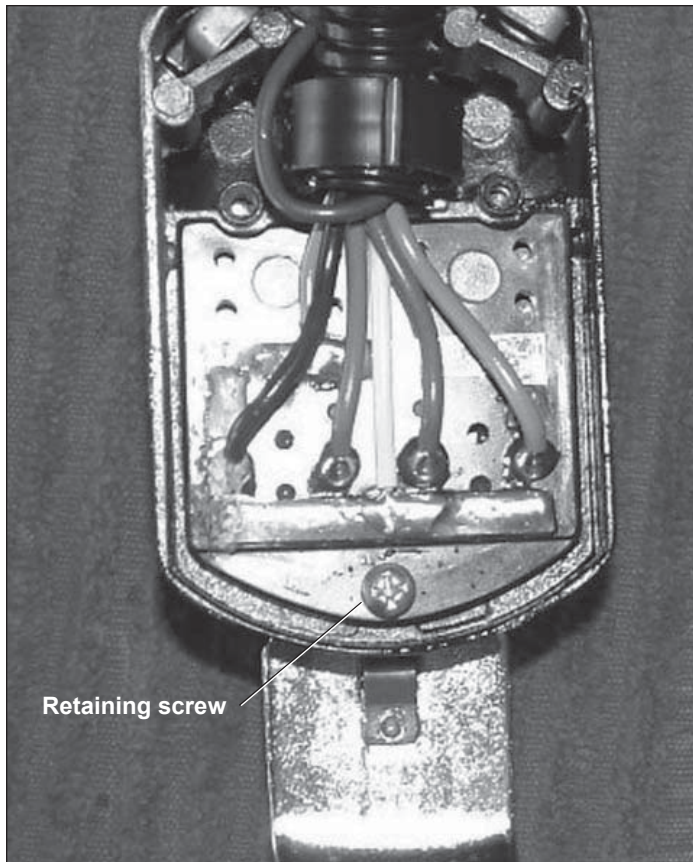


Figure 8-18. Steering Wheel and Turn Signal Assembly Mounting



**Figure 8-19. Turn Signal Control Bulb**



**Figure 8-20. Turn Signal Control Wiring**

This page intentionally left blank.

Columbia / ParCar OEM Parts  
**evtechnicalservices.com**



**SAFETY ..... 9-2**

**GENERAL INFORMATION ..... 9-3**

**BATTERY INSPECTION ..... 9-3**

**BATTERY CLEANING ..... 9-3**

**BATTERY SERVICE (WATER) ..... 9-4**

**BATTERY CHARGING ..... 9-5**

**DELTA-Q CHARGER OPERATION ..... 9-8**

**RED LIGHT CHARGER ERROR CODES ..... 9-8**

**CHARGING PROCEDURE ..... 9-9**

**SPECIAL CHARGING PROCEDURE  
FOR EXCESSIVELY DISCHARGED BATTERIES ..... 9-10**

**TESTING BATTERIES ..... 9-10**

**STORING BATTERIES ..... 9-12**

**REPLACING BATTERIES ..... 9-12**

**BATTERY CHARGER ..... 9-12**

Columbia ParCar OEM Parts  
evtechnicalservices.com  
  
TECHNICAL SERVICES



**ELECTRIC VEHICLE SERVICE**

When servicing the electric vehicle always observe the following:

**! SAFETY FIRST !**

**Always turn Power key to OFF, Directional key switch to Neutral, remove Power key, block tires and disconnect the battery negative (-) cable before performing any vehicle service to avoid accidental startup of vehicle and possible personal injury.**

**SAFETY**

**⚠CAUTION**

Only deep cycle batteries designed for electric vehicle service should be used.

**⚠WARNING**

Batteries contain sulfuric acid which is highly corrosive and can cause chemical burns.



Avoid contact with skin, eyes or clothing.

**SAFETY FIRST**  
PPE required

**Use gloves, eye wear & protective apparel with all hazardous chemicals. (splash or physical hazard present)**

Always wear approved eye protection when working around batteries. Do not smoke around batteries.



All batteries used in electric vehicles can explode! Always wear full face shield when working on or near batteries. Hydrogen fumes are a natural byproduct of charging and discharging and are extremely explosive.



Do not smoke around electric vehicle batteries. Keep sparks and flames away from batteries. Battery charging should only be done in a well-ventilated area. Refer to *Section 9-Batteries* for details.

Battery is poisonous and emits explosive gases. Do not smoke. Keep sparks and flames away from the vehicle and service area. Ventilate when charging or operating in an enclosed area. Refer to *Section 9-Batteries* for details.



Contains acid! Causes severe burns. Avoid contact with skin, eyes, or clothing. Wear full face shield and rubber gloves when working on or near batteries.

**ANTIDOTES TO BATTERY ACID CONTACT:**

- External: Flush with water. Call a physician immediately.
- Internal: Drink large quantities of milk or water. Follow with milk of magnesia or vegetable oil.
- Eyes: Flush with water for fifteen minutes. Call a physician immediately.

When working around batteries, use approved insulated tools, remove jewelry such as rings, watches, chains, etc. and place an insulating material such as wood, plastic, rubber, etc. over batteries covering all connections.

**▲ WARNING**

The gases produced by a storage battery on charge are highly explosive.

To prevent possible personal injury, charge batteries in a well-ventilated area, keep fire and flame away from battery charging area.

**▲ WARNING**

Do not attempt to charge a battery if it is frozen or if the case is bulged excessively. Frozen batteries can explode. Dispose of battery.

**GENERAL INFORMATION**

**Battery Types**

**DEEP CYCLE, LEAD ACID, FLOODED CELL**

Columbia recommends: U. S. Battery, model 2200, XB or XC, 225 amp hour, or U. S. Battery, model 145, XC, 244 amp hour.

**48 VOLT SYSTEMS**

220 amp hour, 105 minute, 6-volt, 8 each

**ELECTRIC VEHICLE BATTERY**

The storage battery receives, stores, and delivers electrical power. This receiving, storing, and delivering of electrical power is called a cycle.

Receive- Charging vehicle batteries.

Store- Vehicle standing idle.

Deliver-Driving vehicle.

Batteries furnished for electric vehicle operation are specially constructed for this type of service.

Automotive batteries are designed to furnish high current draws for short duration, and are kept in a near fully charged state by the charging system.

Electric vehicle batteries must be able to furnish currents up to 50 amperes for long durations, and also be able to supply that current while in a partially discharged condition. This type of service requires a deep cycle battery - a battery that is durable enough to withstand repeated complete cycling.

For this reason, electric vehicle batteries are constructed with heavier plates and cells with a greater capacity for electrolyte.

**▲ CAUTION**

Only deep cycle batteries designed for electric vehicle service should be used.

**BATTERY INSPECTION**

Batteries should be carefully inspected every 8 hours of operating time, or weekly, whichever comes first.

This procedure should also be followed before any tests are performed on the batteries.

- Battery must be clean and dry. Dirt and electrolyte on top of battery causes battery to self discharge. Clean battery top with baking soda (sodium bicarbonate) and water solution (5 teaspoons baking soda per quart water). Do not allow solution to enter cap vent holes.
- Inspect battery posts, clamps and cables for breakage, loose connections and corrosion. Clean battery posts and clamps.
- Be sure battery hold downs are properly tightened. A loose hold down may allow the battery to become damaged from vibration or jarring. A hold down that is too tight may buckle or crack the battery case.
- Check to see that battery cap vent holes are clear. Plugged vent holes will not permit gas to escape from the cell and could result in battery damage.
- Check electrolyte level. Sufficient distilled water would be added to cover plates before charging, then after charging, remaining distilled water can be added to bring electrolyte to correct level.
- Inspect battery case for cracks or leaks.

**BATTERY CLEANING**

Battery terminal connections should be individually cleaned and maintained annually. More frequent cleaning may be required under heavy use, or as batteries age.

**NOTICE**

Make note of any accessory wire connections before disconnecting batteries. Refer to wiring diagrams for proper connection.

1. Remove battery cables and wire connections from all battery terminals.
2. Brush battery cable and wire connections clean using soft brass wire brush.
3. Replace battery cable terminals that are damaged or corroded.
4. Hose off the tops of the batteries and all around the batteries to flush out the battery box/tray. The batteries supplied with the vehicle are flooded cell, with electrolyte (acid) inside. Replenish with distilled water only to top of plates.
5. Keep the batteries clean, fully charged, properly secured and terminal connections tight. Do not over tighten connections. Acid soaked dirt on the battery tops causes current leakage, reduced battery efficiency and promotes rapid self-discharge during storage.
6. Hose wash battery tops periodically with clean, low-pressure water to keep them free of acid spillage, dirt and other debris. If vented batteries are used, make sure vent caps are secure before washing. Do not hose wash electronic controllers, switches, solenoids, and other electrical control devices. Direct water away from these components, covering them if necessary.
7. Wash battery tops with a baking soda mixture (1/2 cup per quart) of water) and a stiff non-metallic bristle brush if a low-

pressure hose does not remove the direct. Rinse with clean water. Take care to ensure that the baking soda mixture does not enter the vent opening in the battery caps.

8. Make sure that the battery tops are clean and dry before putting the batteries into storage.

## BATTERY SERVICE (WATER)

### General

The operating environment of the electric vehicle could vary widely. Severe service operations will require that periodic maintenance recommendations be adjusted to shorter time intervals.

Examples of severe service would include the following:

- Dusty or sandy locations such as cement plant, lumber or flour mills, coal dust or stone-crushing areas.
- High temperature areas such as steel mills, foundries, etc.
- Sudden temperature changes such as continuous indoor-outdoor movement, as in refrigeration plants, bakeries, etc.

### Adding Water To Battery

US Battery, the brand that comes in the new Columbia electric vehicle, features SpeedCap™ battery cell caps. See Figure 9-1.

To open SpeedCap™

1. Locate the two tabs on either side of the center cell of the battery.
2. Move these tabs in the directions shown in Figure 8-1.

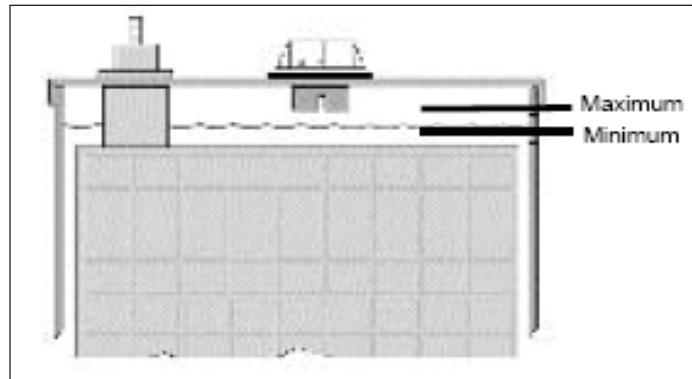
#### NOTICE

**Do not use SpeedCaps™ as handles to lift or move battery.**

3. Check the electrolyte level on brand new batteries before putting them into service, and at least weekly on batteries in service. Water use increases as batteries age.
4. Never allow the electrolyte level to fall below the top of the plates. If the plates are exposed, add only enough distilled water to cover the plates before charging.
5. Do not overfill batteries. Do not fill the water level up into the well of the filler tube of the cell. Electrolyte expands and can overflow during charging. Water added to replace the spillage dilutes the electrolyte and reduces its specific gravity. Cells with lower specific gravity have lower charging capacity.
6. Make sure the electrolyte covers the plates before charging.



**Figure 9-1. Opening SpeedCap™ Battery Cell Caps**



**Figure 9-2. Electrolyte Levels**

Fill cells to the markers only after batteries are charged. See Figure 9-2.

7. Use only distilled water. Electric vehicle batteries may use up to 16 quarts (4 gallons) (15.2 liters) of water during their useful lives. Non-distilled water may contain harmful minerals that will have a cumulative adverse effect on battery performance.





**Special Order Single Point Watering System  
- Factory or Dealer Installed**

A high quality on-board watering system can be installed on the batteries in the vehicle.

To water batteries, after charging, follow this procedure:

1. Insert the pump into a jug of distilled water.
2. Remove the dust cover from the single point coupler. Mate the pump coupler to the single point coupler.
3. Squeeze the hand pump bulb with firm pressure to pump water into the battery cells.
4. When the bulb becomes firm, all cells are full.
5. Disconnect the couplers. Replace the dust cover on the single point coupler. Contact the Columbia Customer Service representative for more information or to order. See Figure 9-3.

**BATTERY CHARGING**

**General**

**▲ DANGER**

Observe all safety information in this section, safety information listed at the beginning of this section, and safety information in *Section 1* of this manual.

Columbia electric vehicles are equipped with a solid state, on-board, fully automatic, Delta-Q Battery Charger as standard equipment. See Figure 9-4.

It is important to be aware of the differences and improvements over prior chargers, which are explained in the Delta-Q Charger Operating Instructions that accompany every vehicle.

Correct charging methods extend battery life and vehicle range between charges. Before the first new vehicle use, completely charge new batteries. Charging time is affected by age of battery, condition of battery, state of discharge, temperature of electrolyte,

AC line voltage level, and other variables. Charging time usually takes 12 hours. New batteries need up to four hours more charging time than "mature" batteries.

Always schedule enough charging time so that the charger completes a full charge cycle. Opportunity charging is an acceptable practice for use during a shift to extend the range, but always allow for a full charge cycle at end of shift.

Limit the use of new batteries between charges for the first 15 – 20 cycles. New batteries have less capacity than batteries which have been cycled.

Recharge batteries immediately after use. Leaving batteries in a state of discharge will reduce their capacity and useful life.

Battery chargers are voltage specific; 24, 36 or 48 volts. However, chargers can be programmed at the factory for different types of batteries, as well as different brands and capacities of batteries. Refer to Battery Brand Algorithms for Charger Programming, See Figure 9-5.

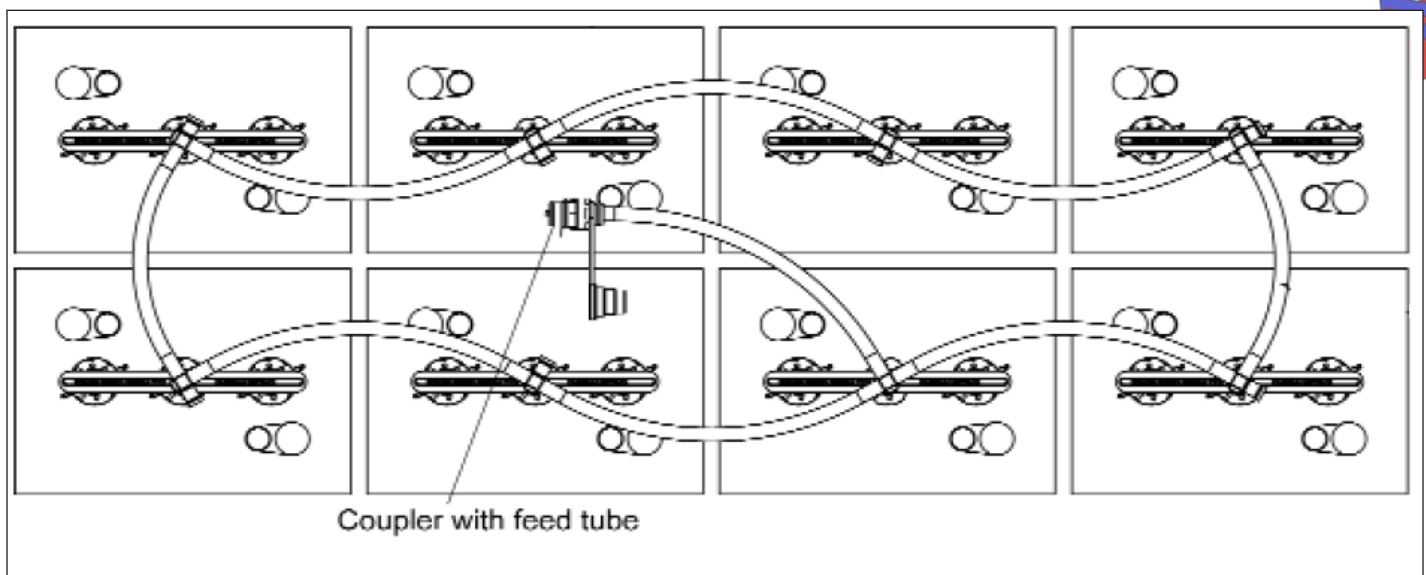
The lead-acid storage battery supplies electrical power through the chemical action. This action is reversible, which means the battery must be connected to a charger and have an electrical current passed through it in the direction opposite to the direction of discharge in order to restore the battery's active chemicals.

The Delta-Q Charger will not over charge batteries if left plugged in.

**Charger Safety Information**

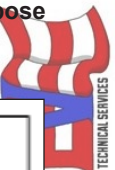
**▲ WARNING**

**Do not attempt to charge a battery if it is frozen or if the case is bulged excessively. Frozen batteries can explode. Dispose of battery.**



**Figure 9-3. Special Order Single Point Watering System**

Columbia / ParCar OEM Parts  
evtechnicalservices.com





- Charge batteries in well ventilated area.
- Ventilation fans should be located at the highest point in charging area. These fans should be able to exchange the air 5x per hour. Consult a local HVAC engineer.
- Remove rings and watches prior to service. Only trained technicians should repair or service the charger. Contact Columbia for assistance.
- Replace worn, cut or damaged power cords or wires.
- Do not connect the power cord near fuels, grain dust, solvents, thinners, or other flammables.
- Install surge arrestors on incoming AC power lines. This protects from all but direct or close proximity lightning strikes.
- Do not cover charger cabinet cooling fans. This protects the charger from overheating.
- Make sure all battery and charger connections are clean and tight. This prevents overheating and arcing at the terminal. Replace as necessary.
- Disconnect negative (-) cable first to avoid crossing terminals that would create a spark.

**NOTE:** When using ordinary automotive chargers, there is the possibility of overcharging and damaging the cells.

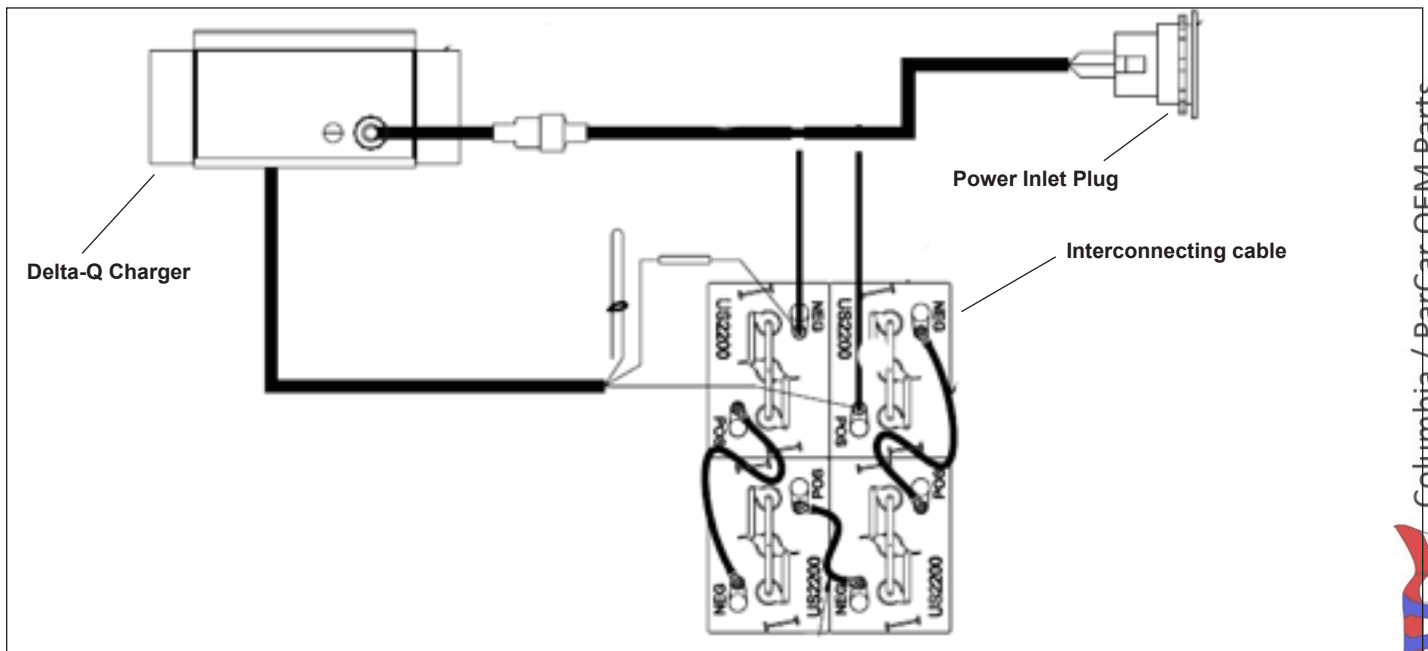


Figure 9-4. Charging System

Algorithm ID	Algorithm description	Amp hour	Type	Designed for	Compatible with
1	Trojan flooded	225	flooded	Trojan T105	Trojan 150 Ah – 260 Ah flooded
2	Trojan T105 tapped	225	flooded	Trojan T105	Trojan 150 Ah – 260 Ah flooded
3	Trojan T105 constant power dv/dt	225	flooded	Trojan T105	Trojan 150 Ah – 260 Ah flooded
4	US Battery flooded	225	flooded	US 2200	US Battery 165 Ah - 245 Ah flooded
5	Trojan 30 XHS	130	flooded	Trojan 30 XHS	Trojan 85 Ah – 150 Ah 12 V flooded, Exide Orbital AGMs
6	Deka 8G31 Gel	100	gel	Deka 8G31	Deka 75 Ah – 100 Ah gel
7	Trojan J305 constant power dv/dt	305	flooded	Trojan J305 series	Trojan 250 Ah – 400 Ah flooded US Battery 250 Ah – 400 Ah flooded
8	Concorde 10xAh AGM	100	AGM	Concorde 100 Ah Range AGMs	-
11	Generic flooded constant power dv/dt (parallel enabled)	230	flooded	US Battery US 125	All 200 - 255 Ah flooded
12	Exide gel	240	gel	Exide DF06240	Exide/Sonnenschein 200 Ah – 300 Ah gel
21	Exide flooded	210	flooded	Exide 3ET200, FF06255, 185PZB210	Exide 200 Ah - 300 Ah flooded
23	Douglas constant power dv/dt	200	flooded	-	T105, T125, T145, T875, T890, US 220, US 125, US 145
26	Deka 8GGC2 Gel	180	gel	Deka 8GGC2	Deka 180 Ah – 200 Ah gel
27	Crown CR-325 dv/dt	325	flooded	Crown CR-325	Crown 225 Ah – 350 Ah flooded
32	Deka EV31 dv/dt	110	flooded	Deka EV31	Deka 75 Ah – 150 Ah gel
35	Concorde 2xxAh AGM	200	AGM	Concorde 200 Ah range AGMs	-
37	Trojan T105 constant power dv/dt 42V pack w/ 48 v charger	225	flooded	Trojan T105	Trojan 150 Ah – 260 Ah flooded
38	Trojan 1275 113%	150	flooded	Trojan T1275	Trojan 130 Ah – 180 Ah flooded
41	Crown CR395	395	flooded	Crown CR-395	Crown 350 Ah – 400 Ah flooded
43	Discover AGM	300	AGM	Discover EVL16A, EVGC6A	Discovery 200 Ah – 400 Ah AGM
47	Generic 20Ah VRLA pulse	20	AGM	-	-
51	Exide 180 Ah gel	180	gel	Sonnenschein 180Ah gel	-
52	Exide 105 Ah gel	105	gel	Sonnenschein 105Ah gel	-
57	Sacred Sun AGMs	170	AGM	Sacred Sun 140-200 Ah AGMs	-

Columbia / ParCar OEM Parts  
evtechnicalservices.com



**Figure 9-5. Algorithm Table**

**DELTA-Q CHARGER OPERATION**

1. Connect power cord at charger receptacle to properly grounded wall outlet.

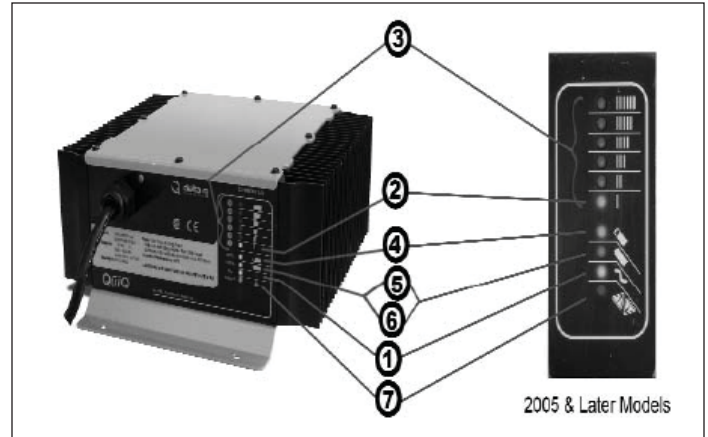
**NOTICE**

**Connect the charger AC cord to a source capable of supplying 15 amperes minimum per charge (20 amperes recommended). The charger is equipped with an equipment-grounding AC electric cord, and a grounding type plug.**

2. Connect the cord to an appropriately installed receptacle grounded in accordance with the National Electric Code ANSI/NFPA 70, and all local codes and ordinances.
3. The yellow AC power LED (1, Figure 9-6) should remain illuminated while the charger is plugged into an AC source. If yellow LED (1) is not lit, before replacing charger, confirm the two AC connections supplying the charger on the vehicle are intact. First, check the extension cord receptacle, found on right side of the vehicle's console. Then check the three pronged connection on the short 6 inch AC cord extending from the LED panel. Also confirm the AC source fuse or breaker operation, then contact the Columbia Dealer for assistance.
4. Charger will automatically turn on and conduct a short self-test and battery pack test. All LEDs will flash in sequence, then a trickle current will be applied to batteries until a minimum voltage is reached. Three (3) amperes is displayed as the lowest LED on the Bar Graph. See (2, Figure 9-6).
5. If the batteries meet the minimum voltage requirements of the charger, signifying they are serviceable (chargeable), the charger enters the bulk charging (higher amperage-constant current) stage. The current (A) Bar Graph LEDs (3, Figure 9-6) indicates the electrical current delivered to the batteries as the charger moves through its automatic charge profile. The length of charge time at each level will vary due to battery size and battery charge depletion.

If the charger only reaches the trickle stage (No. 2 above), and does not enter the higher rate Current (A) Bar Graph region with a steady LED lit, the batteries may be excessively discharged, and not capable of automatic charge with the Delta-Q. The charger may time-out with a RED Fault LED (7, Figure 9-6). (*Flash Code Faults - See Red Light Charger Error Codes*). It will then be necessary to follow the *Special Charging Procedure* Section. Also review the Battery Maintenance Procedures.

6. When the yellow 80% LED is lit, the Charger has completed the bulk stage and the batteries are at approximately 80% state of charge. The 80% LED remains on as the last 20% of charge is returned to the batteries in the second phase (constant voltage phase) (4, Figure 8-5).
7. Operator can terminate charging at this point if necessary. The vehicle can be used, but completing the charge cycle is highly recommended, until the 100% Green LED is lit (5, 6, Figure 9-6). Repeated "short charging", leaving the charge short of 100%, will shorten operating cycle distance and reduced battery life.



**Figure 9-6. Delta-Q Charger and Lights**

8. A low current "finish-charge" phase returns and maintains batteries to maximum capacity. The Green LED will blink until "finish charge" phase is complete. On vehicles equipped with a battery discharge indicator (BDI), the Red LED display on the dash mounted meter scrolls across from right to left during the finish charge and is normal operation.
9. A Green LED continuously lit, indicates the batteries are completely charged (6, Figure 9-6). The charger may now be unplugged from the AC source. If the vehicle is not operated for a length of time, see *Section 3 - Vehicle Storage*.
10. A fault occurring while charging causes the RED FAULT LED (7, Figure 9-6) to flash with a code relaying the error. Some errors may require repair by a qualified technician and others may be simply transient and will automatically recover when the fault condition is eliminated and the Delta-Q cycled by disconnecting the AC source a minimum of 11 seconds. See *Red Light Charger Error Codes*.

**NOTICE**

**A yellow (amber) Blinking LED in the upper Bar Graph usually indicates the thermostatic control has limited the charger output due to ambient temperature conditions - it is still charging, but at a reduced rate.**

**The Yellow AC power LED should remain illuminated while the charger is plugged into an AC source. If charger does not power up, after following the instructions described, then contact the Columbia Dealer for assistance.**

**NOTICE**

**Do not disassemble the charger. There are no serviceable parts.**

**RED LIGHT CHARGER ERROR CODES**

**1 Flash**

Battery Voltage High: Auto-recover. May be temporary condition, or wrong charger installed, i.e. 36 volt charger on 48 volt battery pack.

**2 Flash**

Battery Voltage Low: Auto-recover. Confirm each individual batteries minimum voltage with a volt meter Two or more 6 volt batteries

Columbia / ParCar OEM Parts  
 eotechnicalservices.com  
 TECHNICAL SERVICES

register less than 5.85 volts, or accumulative total pack voltage has been discharged to less than 20% remaining. Vehicle operation will cease until batteries are recharged. See Special Procedure for Excessively Discharged Batteries in this section.

**3 Flash**

**Charge Timeout:** The charging did not complete in allowed time, 12-14 hours. This may indicate a battery problem, or that the charger output was reduced due to high ambient temperatures. Disconnect AC supply, confirm sufficient ventilation, allow cool down time, and restart charger.

**4 Flash**

**Check Battery:** The batteries could not be trickle charged up to a minimum level to start charger. This may be the result of badly discharged batteries, or one (or more) damaged cells. See Special Procedure in this section.

**5 Flash**

**Over-Temperature:** The charger shut down due to high internal temperature. May require reset (AC unplugged) and a cool down to restart charging cycle. This fault may indicate inadequate cooling airflow or high ambient air temperatures. Check for debris or blockage at cooling fans. Move the vehicle to a cooler better ventilated area, or adjust time of day when charging.

**6 Flash**

**Delta-Q Charger Fault:** An internal fault was detected and charger may need to be checked/replaced by a qualified dealer technician. It may also be the result of badly discharged batteries, or one (or more) damaged cells. A RED 6 FAULT flash must be validated first by testing individual batteries with a voltmeter, and see Special Procedures, before deciding charger has failed.

**A Steady Red Fault LED**

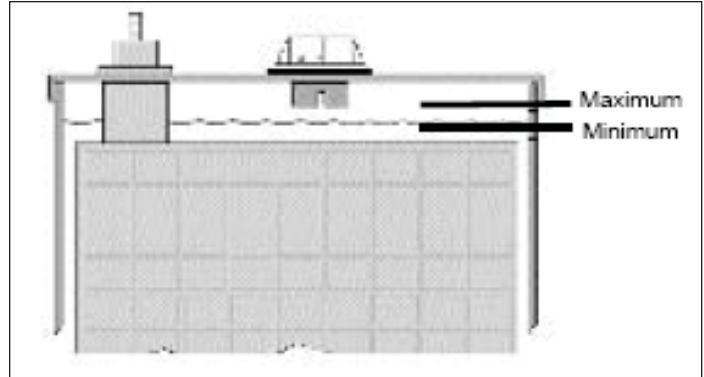
Confirms an internal electrical fault of the Delta-Q and also requires charger replacement and return.

**Yellow (amber) Blinking LED in the Bar Graph Area**

Usually indicates a thermostatic control has limited the charger output due to ambient temperature conditions. It is still charging, but at a reduced rate.

**CHARGING PROCEDURE**

1. Check electrolyte level in all cells. Add distilled water as necessary to cover tops of plates. Do not overfill, as electrolyte expands during charging.
2. Be sure charger is turned OFF. Insert electrical plug into vehicle's charger receptacle.
3. Charger will start automatically. Check that amp meter rises fully when charger starts. If charger needle only rises to half scale or does not rise at all, check AC outlet for proper power supply or check charger owner's manual for testing and repair information.
4. Whenever a manual charger is used, refer to the following table for battery condition/ state of charge testing.



**Figure 9-7. Electrolyte Levels**

State of Charge vs. Specific Gravity	
State of charge	Specific gravity @ 80° F (26° C)
100%	1.250 – 1.270
75%	1.220 – 1.240
50%	1.190 – 1.210
25%	1.160 – 1.180

*Note: Specific gravity taken from at least 2 cells of each battery.*

The specific gravity check is most accurate for determining battery state of charge. Charger function is totally automatic. Charger will determine proper charge time.

5. After charging, check electrolyte level. Add water as necessary. Water must be over the battery plates while still under the bottom of the caps. See Figure 9-7.

**CAUTION**

**Avoid further charging after the batteries are fully charged and equalized. Practical charging time maximum is 12 hours, except for new batteries. New batteries may require up to 4 additional hours charge time.**

**Conditions That Affect Charging**

- If vehicle is used only occasionally, a refresher charge should be given prior to using the car. Use specific gravity reading to determine if charge is required. Charger will determine length of charge required.
- Fleet vehicles should be rotated so that all vehicles are used equally.
- Battery efficiency is affected by temperature. See the following table.

Columbia / ParCar OEM Parts  
evtechnicalservices.com





Power percentage available from fully charged batteries at various temperatures	
State of charge	Temperature
100% 80°F	(26°C)
65% 32°F	(0°C)
40% 0°F	(-18°C)

- As batteries age, they finish charge at progressively higher charge rates and tend to use more distilled water. At this point in battery age, charger will automatically begin reducing charge time.
- If batteries are unusually hot at the end of normal charge with heavy deposits of moisture around the filler caps and/or water use is high, this may indicate one or more defective cells or that the batteries are nearing the end of their useful life. See *Testing Batteries* in this section.
- If the batteries do not respond to normal charging, one or more cells may be defective and all should be checked. See *Testing Batteries* in this section.

Batteries found defective must be replaced. All batteries in a vehicle should be matched according to age, capacity and brand.

The charger can be used to determine the overall condition of the battery bank after charging. Compare the finish charge rate with the specific gravity readings of the batteries. See the table below.

### SPECIAL CHARGING PROCEDURE FOR EXCESSIVELY DISCHARGED BATTERIES

#### NOTICE

**The Delta-Q Automatic Battery Charger will not charge a dead battery. Each battery will need to be brought up to an acceptable state of charge, and establish that it does not have an internal fault or bad cell. If a battery has remained too long in a discharged state, it may be internally damaged and not capable of accepting a charge. It must be replaced.**

If the Delta-Q Battery Charger does not reach the full charging mode, identified by a steady LED in the upper region of the Bar Graph display (18/15/12...), or the RED Fault Light is lit, it may indicate that the minimum voltage is not present to allow the charger to control the charging of the complete set of batteries. If the electrolyte specific gravity is low (less than 1.140 SG), or the individual battery voltage is less than 5.25 volts for three cells (or 10.50 volts for 6 cells), it will need to be recharged with an ordinary automotive style trickle charger at a rate of 3 to 6 amps for several hours each. Follow specific charger instructions.

It is not necessary to disconnect the battery cables, as the alligator style clips can be connected to each positive and negative battery post.

#### ▲ WARNING

**Always disconnect the AC power first when moving the positive/negative alligator clips to prevent a spark from igniting the gas emitted from the batteries.**

Be sure to charge all of the batteries in the set. Each battery may require 2-3 hours of charging to bring it back to serviceable condition. Measure the Specific Gravity (SG) of each cell after this charging procedure is completed, to verify that the battery is OK for use. Replace any batteries that can not be re-charged (no change or improvement in SG). After all batteries have been individually charged, and with the temporary automotive charger removed, try operating the Automatic On-Board Delta-Q Charger again to verify operation. Allow onboard Delta-Q Charger to complete a full charge cycle for proper equalization of batteries. If the 6 Flash Fault persists; an internal fault may be present and the charger will need to be replaced by a qualified dealer technician. A STEADY RED FAULT LED confirms an internal electrical fault of the Delta-Q, and also requires charger replacement and return.

### TESTING BATTERIES

#### Testing with a Charger

The charger can be used to give an overall test of the battery bank after it has received a full charge. The finish charge rate of a good set of batteries is 3-5 amps as read on the charger ammeter.

1. Connect on board charger to an AC power source and turn on.
2. Charger ammeter needle should jump to 15 amps or more and then taper into the 1-3 amp area within 15 minutes, indicating good fully charged batteries.
3. Battery banks failing this test should be tested with hydrometer and/or load tester. See *Specific Gravity Test*.

#### Specific Gravity Test

It is possible to determine a battery's ability to perform by measuring the specific gravity of each cell with a hydrometer. The hydrometer readings indicate two things:

- State of Charge - The amount of electrical power stored in the battery.
- Condition - The ability of battery to store and deliver power.

#### NOTICE

**Batteries should be fully charged before performing specific gravity tests to determine battery condition. Hydrometer tests of batteries not fully charged are misleading and inconclusive.**

#### Hydrometer Test

1. Squeeze rubber bulb and insert nozzle in cell, release bulb, slowly drawing electrolyte up into barrel.
2. Adjust electrolyte level in barrel so float rides free of bottom but is not striking top of barrel.
3. Hold hydrometer vertically, making sure float moves freely and is not contacting sides of barrel. Read scale at the level of electrolyte in the barrel. Record the reading.
4. Return electrolyte to cell from which it was removed.
5. Repeat these steps on all battery cells.

Hydrometer readings are affected by the temperature of the electrolyte being tested. Measure the temperature of the electrolyte, and correct the readings as follows:

**Above 80°F:** Add .004 to the specific gravity readings for each 10° above 80°F (26°C).

**Below 80°F:** Subtract .004 from the specific gravity readings for each 10° below 80°F (26°C).

**INTERPRETATION OF HYDROMETER READINGS**

If the difference between the highest and lowest cell is 0.050 (50 points) or more, the battery is nearing the end of its useful life and should be replaced.

Specific Gravity vs. State of Charge	
Specific gravity reading @ 80° F (26° C)	State of charge in percentage
1.250 - 1.270	100%
1.220 - 1.240	75%
1.190 - 1.210	50%
1.160 - 1.180	25%

If the highest cell reads less than 1.2, the test for condition is questionable. Recharge the battery and perform test again.

Specific Gravity vs. Action Required				
battery	Specific gravity reading for each cell			Required action
	Cell 1	Cell 2	Cell 3	
1	1.100	1.100	1.100	Charge and recheck
2	1.260	1.180	1.250	Bad cell 2. Replace battery
3	1.250	1.260	1.250	Good
4	1.190	1.170	1.120	Charge and recheck. Suspect cell 3

**Discharge (Load) Test**

The discharge, or load test, is the recommended method of determining battery condition because it simulates electric vehicle operation under controlled conditions. A 75 amp draw is applied to the battery bank with a Load Tester. The time it takes the battery bank to drop to 31.5 volts, along with individual battery voltages, is used to determine battery condition.

**NOTICE**

**Use of automotive type of load tester is not recommended and will offer inaccurate results.**

**PREPARATION FOR DISCHARGE TEST**

The following preparations must be verified before discharged load testing. Should any of the following recommendations not be performed, results of testing will be inaccurate and misleading.

- Batteries must receive a full charge before conducting Discharge (Load) Test.
- Discharge (Load) Test must be performed within 18 hours of charging.
- Vehicle must not be used, even for short runs, prior to Discharge (Load) Test.
- Electrolyte level must be correct in all cells.



**Figure 9-8. Typical Commercial Load Tester**

**DISCHARGE (LOAD) TEST PROCEDURE**

**⚠ WARNING**

**Discharge Load Test must be performed in well ventilated area.**

1. Connect tester leads to battery bank.
2. Check and record electrolyte temperature of center cell of each battery.
3. Turn tester on.
4. After 20-30 minutes, with tester on, check and record individual battery voltages to the nearest 0.1 (1/10) volt.

All four individual battery voltage readings for a 24 volt system must be made as rapidly as possible to be accurate.

5. Allow tester to shut off automatically, and record time elapsed from start of discharge.

Tester shutoff should occur at a battery voltage of 42v +/- 0.2v (48 volt system) or 21v +/- 0.2v (24 volt system). Check tester shutoff voltage periodically. This setting must be accurate for a valid test.

**INTERPRETING DISCHARGE (LOAD) TEST RESULTS**

1. Compare individual battery voltages recorded in step 4 of *Discharge (Load) Test Procedure* and discard any battery that is 0.2 (2/10) volt lower than the highest battery in bank. If defective battery is found, recharge the entire bank for 12 hours. Then, replace the defective battery with a good fully charged battery of the same brand and date code, if possible. Equalize the bank by placing it on charge for an additional three hours, then retest.
2. If all battery voltages are within 0.2 volts of each other, compare discharge time from step 4 of *Discharge (Load) Test Procedure* with minimum times in Temperature and Time table on next page.

Even if individual battery voltages are satisfactory but the discharge time fails to meet minimums in Temperature and Time table, the entire battery bank should be replaced.

Columbia / ParCar OEM Parts  
evtechnicalservices.com

Discharge Load Test: temperature and time		
Electrolyte temperature from step 2	Minimum Discharge Time to 3.1 volt from step 5	
40 – 49 °F	4 – 9 °C	40 minutes
50 – 59 °F	10 – 15 °C	45
60 – 64 °F	16 – 17 °C	50
65 – 69 °F	18 – 20 °C	54
70 – 74 °F	21 – 23 °C	57
75 – 79 °F	24 – 25 °C	60
80 – 84 °F	26 – 29 °C	62
85 – 89 °F	30 – 32 °C	64
90 – 99 °F	33 – 37 °C	66
100 – 109 °F	38 – 43 °C	68
110 – 119 °F	44 – 48 °C	70
120 – 129 °F	49 – 54 °C	72
130 – 150 °F	55 – 66 °C	74

**STORING BATTERIES**

- Batteries can remain in vehicle.
- Batteries should be fully charged.
- Clean battery tops and connections.
- Fully charged batteries should be stored in as cold of an environment as possible. Batteries “self discharge” when not in use. The colder the temperature, the slower batteries self discharge.

**CAUTION**

**Batteries in low state of charge (low specific gravity readings) will freeze at higher temperatures than those fully charged.**

Check specific gravity periodically, and recharge batteries as necessary. Batteries stored in temperatures above 80°F (26°C), will discharge faster and require recharge every few weeks. Batteries stored at or below 0°F (-12°C) may not require recharge for periods up to 4 months. When recharging, bring batteries to 1.250-1.270 specific gravity to prevent freezing. See Table 8-8.

As ice forms in a freezing battery, the electrolyte expands and can crack the case, ruining the battery. If a battery is allowed to stand or is operated in a discharged condition for a long period of time, lead sulfate may develop on the plates, which is dense, hard and crystalline, and which cannot be electrochemically converted to normal active material again.

Lead sulfate formed on the plates during discharge is relatively insoluble as long as the specific gravity of electrolyte is kept above 1.125 specific gravity, but if allowed to drop below this value, the lead sulfate becomes increasingly soluble and may migrate into the pores of the separators and deposit as a white crystalline mass.

Subsequent charging may convert these deposits into stringy metallic lead which may short the positive and negative plates through the areas affected. These small shorts may cause a condition of low cell voltage when battery is allowed to stand idle in less than 25% charged condition.

State of Charge and Specific Gravity vs. Risk of Sulfation				
State of charge	Specific gravity	F° freezing point	C°	Risk of sulfation
100%	1.260	-70 °	-57 °	low
75%	1.230	-39 °	-38 °	low
50%	1.200	-16 °	-26 °	low
25%	1.170	-2 °	-19 °	moderate
discharged	1.110	+17 °	-8 °	high

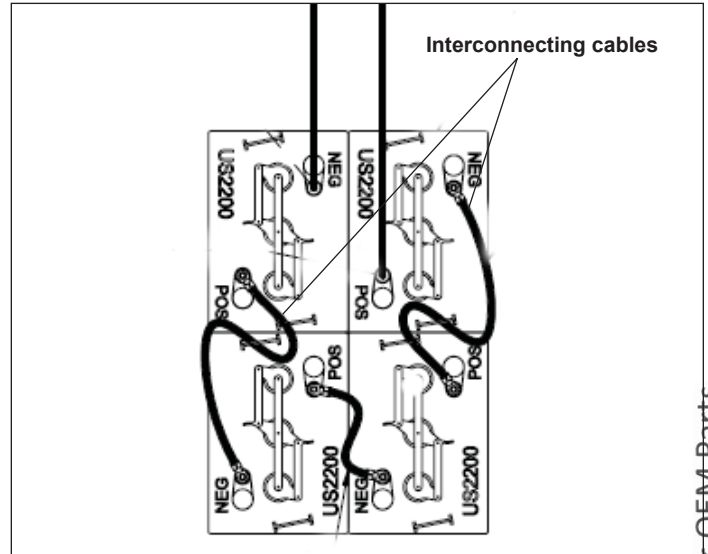


Figure 9-9. Battery Cables

**REPLACING BATTERIES**

**Removing Batteries**

1. Remove nuts, washers and cables, positive lead and negative lead interconnecting batteries. See Figure 9-9.
2. Remove nuts, flat washers, hold down plates and rods. See Figure 9-10.
3. Remove batteries.

**Installing Batteries**

1. Install batteries.
2. Install rods and hold down plates).
3. Install flat washers, nylock nuts.

**BATTERY CHARGER**

**Removal**

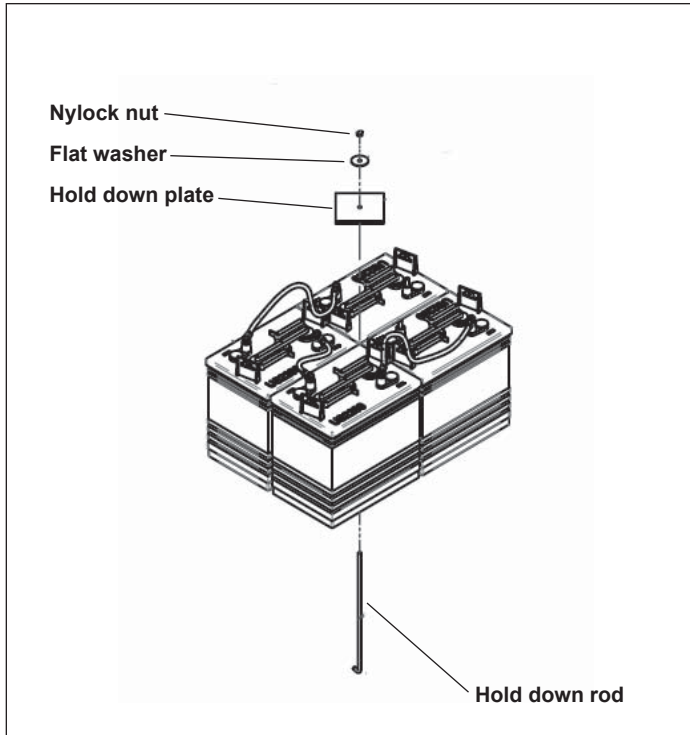
**NOTICE**

**There are four wires in the output lead from the charger; black and white together to battery B-; red wire to battery B+; green wires to connector on red wire #14 on the interlock circuit. The black and white wires are terminated in a thermistor. Take extra care when handling the thermistor.**

1. Disconnect 4 wires in charger output lead from battery B-, battery B+ and wire 14. Unplug power inlet cable from charger pigtail.
2. Remove four nuts, four washers, four bolts and charger. See Figure 9-11.

Columbia / ParCar OEM Parts  
evtechnicalservices.com

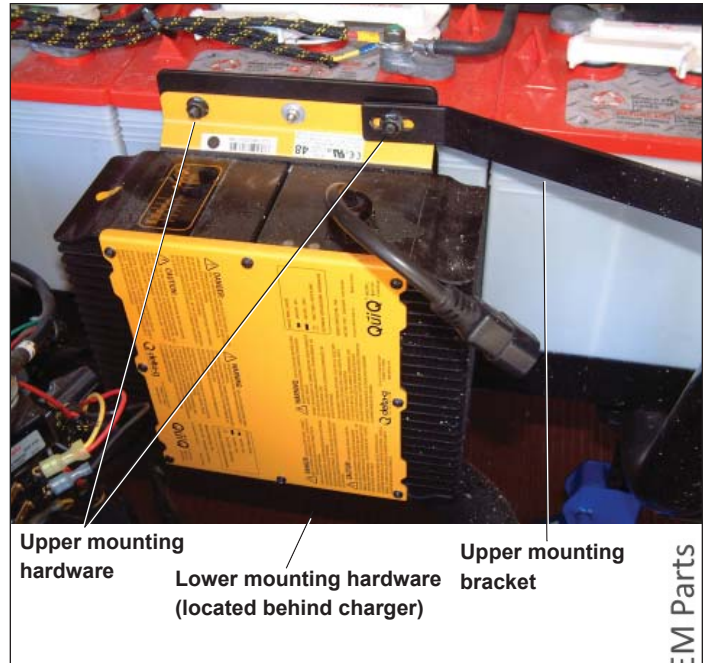




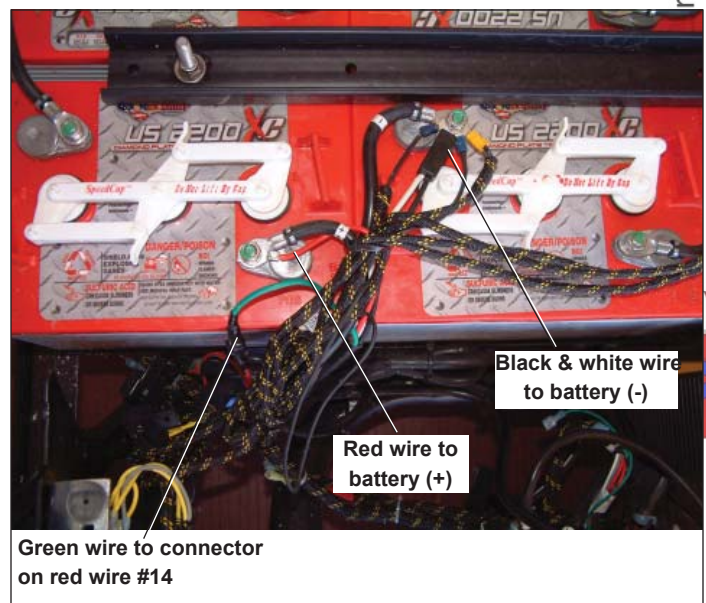
**Figure 9-10. Battery and Hold Downs**

**Installation**

1. Position new charger to mounting bracket. See Figure 9-11.
2. Secure new charger with four nuts, washers and bolts. Tighten charger attaching hardware.
3. Install charger output electrical leads as follows; black and white to battery B-, red wire to battery B+, green wire to red wire #14 from interlock harness. See Figure 9-12. Plug in cord from power inlet to charger pigtail. Tape the two plugs together so they cannot accidentally separate.
4. Bundle up the excess charger output cable and secure it neatly with wire ties.
5. Reconnect battery negative cable. Install Power key.
6. Power key ON. Check BDI display.



**Figure 9-11. Charger and Bracket**



**Figure 9-12. Battery Wires**

OEM Parts  
 evehiclestools.com  
 TECHNICAL SERVICES



This page intentionally left blank.

<b>TRACTION MOTOR</b> .....	<b>10-2</b>
<b>Maintenance</b> .....	<b>10-2</b>
External Motor Inspection .....	<b>10-2</b>
Internal Motor Inspection .....	<b>10-2</b>
Traction Motor Removal .....	<b>10-2</b>
Traction Motor Disassembly .....	<b>10-3</b>
Armature Inspection .....	<b>10-3</b>
Armature Testing.....	<b>10-4</b>
Brushes .....	<b>10-4</b>
Brush Springs .....	<b>10-4</b>
Bearing .....	<b>10-6</b>
Frame and Field Coils .....	<b>10-6</b>
Field Coil Maintenance .....	<b>10-6</b>
Inspection .....	<b>10-6</b>
Traction Motor Reassembly .....	<b>10-6</b>
Traction Motor Installation .....	<b>10-7</b>
<b>CONTROLLER</b> .....	<b>10-8</b>
Smart <i>drive</i> Traction Motor System .....	<b>10-8</b>
ACE <i>plus</i> Traction Motor System .....	<b>10-8</b>
Controller Testing .....	<b>10-8</b>
Removing the Controller .....	<b>10-8</b>
Installing the Controller .....	<b>10-9</b>
<b>CONTACTOR/SOLENOID</b> .....	<b>10-9</b>
Removing the Contactor .....	<b>10-9</b>
Installing the Contactor .....	<b>10-9</b>

Columbia / ParCar OEM Parts  
 evtechnicalservices.com  


**ELECTRIC VEHICLE SERVICE**

When servicing the electric vehicle always observe the following:

**⚠ SAFETY FIRST ⚠**

**Always turn Power key to OFF, Directional key switch to Neutral, remove Power key, block tires and disconnect the battery negative (-) cable before performing any vehicle service to avoid accidental startup of vehicle and possible personal injury.**

**TRACTION MOTOR**

**Maintenance**

A good planned maintenance program will save many hours of future down time and prevent catastrophic failure of major motor components. Maintenance schedules consist of periodic routine inspections of motors, battery and wiring circuitry.

Since operation of golf equipment varies widely, the following recommendations are suggested for periodic maintenance inspection:

Normal service – 8 hours per day operation

- Routine inspection every 1,000 hours

Severe service – 24 hours of daily operation

- Routine inspection every 500 hours

**NOTICE**

**Severe service would include; Dusty or sandy locations such as cement plant, lumber or flour mills, coal dust or stone-crushing areas. High temperature areas such as steel mills, foundries, etc. Sudden temperature changes such as continuous in-door-outdoor movement, as in refrigeration plants.**

**External Motor Inspection**

1. Check for clean, tight, terminal studs and mounting bolts.
2. Internal and external spline drives, between motor and final drive axle, must be periodically lubricated with a thin layer of quality, anti-seize compound.
3. Check for any signs of oil leaks from final drive axle, which might cause oil to enter traction motor.

**Internal Motor Inspection**

The brush and commutator inspection is the most important part of motor maintenance. By recognizing undesirable commutator and/or brush conditions, internal repairs can be performed before major component damage or failure occurs.

Brush and commutator inspection can be accomplished by removing the motor head. The brushes and commutator should be inspected for even wear and good commutation.

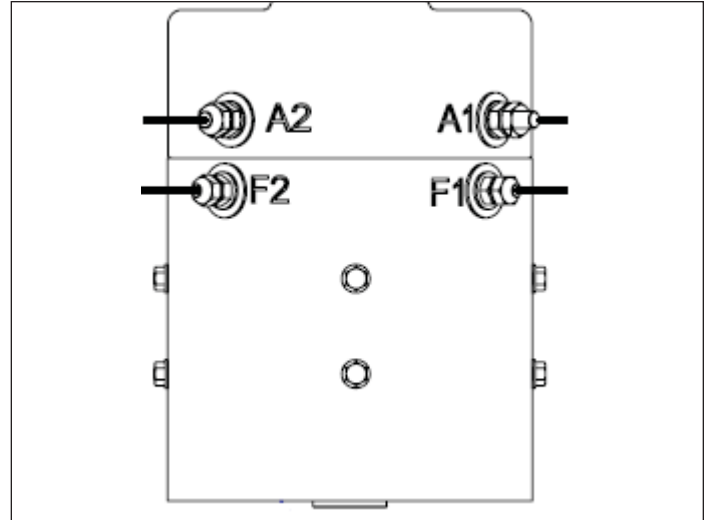


Figure 10-1. Traction Motor Cables Labels

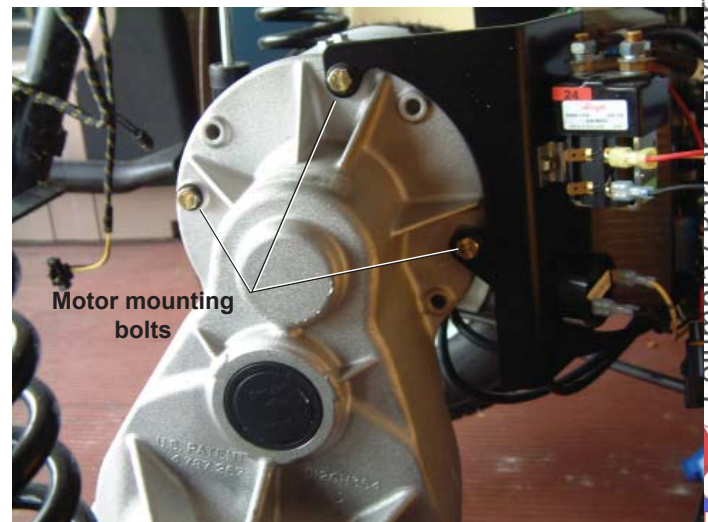


Figure 10-2. Traction Motor Mounting

Good commutation will be indicated by a dark brownish, polished commutator and an evenly polished brush wearing surface. If the commutator appears rough, pitted, scored or has signs of burning or heavy arcing between the commutator bars, the motor should be removed for servicing.

**Traction Motor Removal**

**NOTICE**

**Studs and jam nuts on the electric motor can be damaged when attaching or removing electrical leads. Hold a thin open end wrench on the electrical stud connector jam nut while loosening or tightening attaching nuts.**

1. Mark traction motor cables (if not already marked), with motor terminal identification. Figure 10-1.
2. F1 and F2 terminals are 1/4-20 UNC. A1 and A2 terminals are 5/16-18 UNC. Hold terminal jam nut with a thin open end wrench when loosening and removing hex nuts, lock washers and flat washers securing electrical cables to traction motor.

- See Figure 10-2. Carefully support motor to prevent it from falling, and loosen and remove three bolts, lock washers and f at washers securing motor to rear axle/dif ferential housing. Pull motor away from rear axle housing and lift it clear of the vehicle.

**▲CAUTION**

**Traction motor is heavy and awkward to move. Get help stabilizing and lifting motor to prevent possible personal injury.**

**Traction Motor Disassembly**

- Remove long bolts. Remove motor head hole plug. See Figure 10-3.
- Pull on motor head to remove armature from frame. A light tap may be required to loosen motor head from frame. Motor head and armature come out together.
- Place puller around the motor head. Use the center of the shaft to locate puller. See Figure 10-4.
- Pull motor head assembly off of armature assembly maintaining equal pressure on all sides of head.
- Move brush springs behind spring hooks shown in Figure 10-5.
- Remove 1 hex nut, 1 lock washer 1 hex nut, 1f at washer and 1 insulator at each brush terminal, A1 and A2. Figure 10-6.
- Remove 4 brush plate screws (Figure 10-7). Push brush terminal studs through, into the center of the head as the brush box, brushes and terminal assemblies are removed. (See exploded view Figure 10-9).
- Remove bearing retainer (snap ring) shown in Figure 10-5. Carefully press out the bearing from motor head. Replace the bearing.
- Remove all the brush dust from motor frame, brush box, and motor head.

**Armature Inspection**

- Measure the diameter of the armature (Figure 10-8).
 

Max dia. when new	2.92-2.93" (74 mm)
Min dia. for re-slotting	2.81" (71 mm)
Replacement dia.	2.76" (70 mm)
- Support the armature at both bearing journals. Check run-out of commutator with a dial indicator . Total indicated run-out should not exceed 0.005" (0.12 mm). If the readings fall outside this limit, commutator must be turned and undercut. Figure 10-10.
- After the commutator has been undercut, if required, the armature should be placed in lathe and the commutator lightly sanded with no. 00 sandpaper. This will remove any burrs left from the undercutting operation.
- Clean commutator with dry , compressed air . Recheck commutator runout.

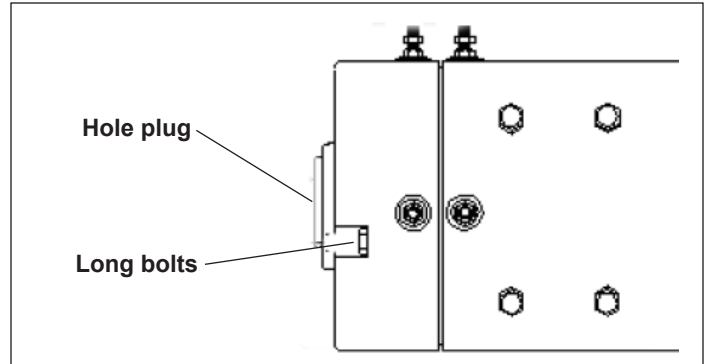


Figure 10-3. Traction Motor Hardware

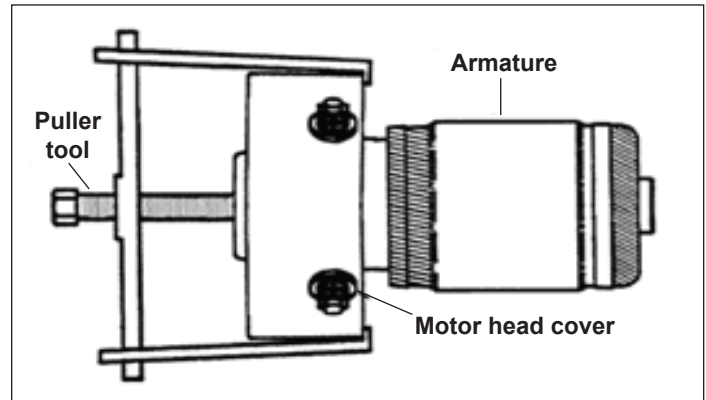


Figure 10-4. Removing Motor Head

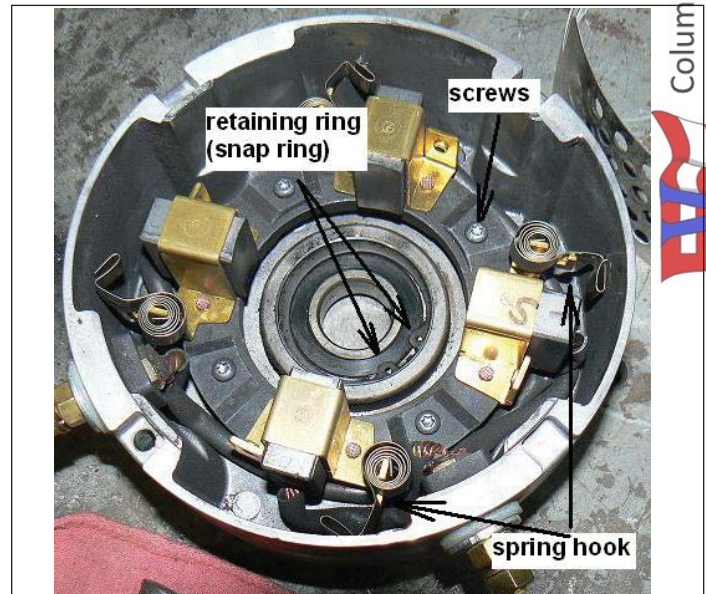


Figure 10-5. Spring Hooks for Brush Springs



**Armature Testing**

Before the armature is reassembled into the motor, the following test should be performed.

1. Check armature for grounded circuits by placing one test lead of a Dielectric Breakdown Tester, also referred to as a “growler”, on the commutator and other lead at armature shaft. The ground test light should not flash. A flash indicates failed insulation between core and armature wiring. See Figure 10-11.
2. For short circuit connection, use a hacksaw blade to locate any shorted windings. Rotate armature slowly in growler jaws and hold a hacksaw blade in parallel against top of armature. The steel blade will be attracted to the core and will vibrate when two shorted armature coils are located. See Figure 10-12.

**Brushes**

Brushes should be inspected for uneven wear and signs of overheating, such as discolored brush leads and brush springs. Check brush box for physical damage. Make sure brush holders are not loose on the brush box assembly. See Figure 10-9.

Check brush for correct clearance and freedom of movement in the holder.

- New brush length: 1.20" (30.5 mm)
- Minimum brush length: 0.60" (15.2 mm)
- Replacement brush length: less than 0.60" (15.2 mm)

If any brushes are worn to the point that replacement is necessary the complete brush set should be replaced. Never replace just one pair of brushes.

Do not substitute brushes. The brushes are matched to the motor type and application to provide the best service. Substituting brushes of the wrong grade can cause commutator damage or excessive brush wear.

**Brush Springs**

Check the brush springs for correct alignment on the brush. A brush spring that does not apply equal pressure on the center of the brush will cause the brush to wear unevenly.

Use the following procedure for checking brushes for proper tension. See Figure 10-13.

1. Place paper strip between brush face and commutator.
2. Hook a commercial spring scale as shown.
3. Pull spring scale on a line directly opposite the spring force. When paper strip can be moved freely read spring tension on scale.

Brush spring tension	new	64 ounces (1792 grams)
	worn	40 ounces (1120 grams)

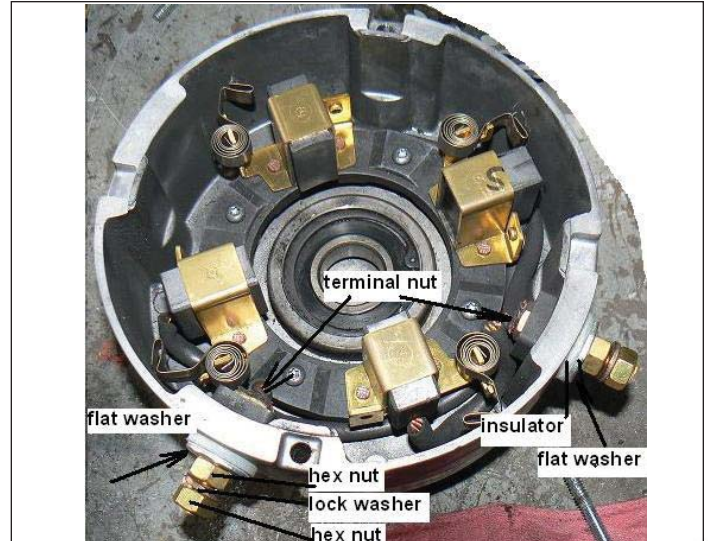


Figure 10-6. Brushes and Terminal Attaching Parts

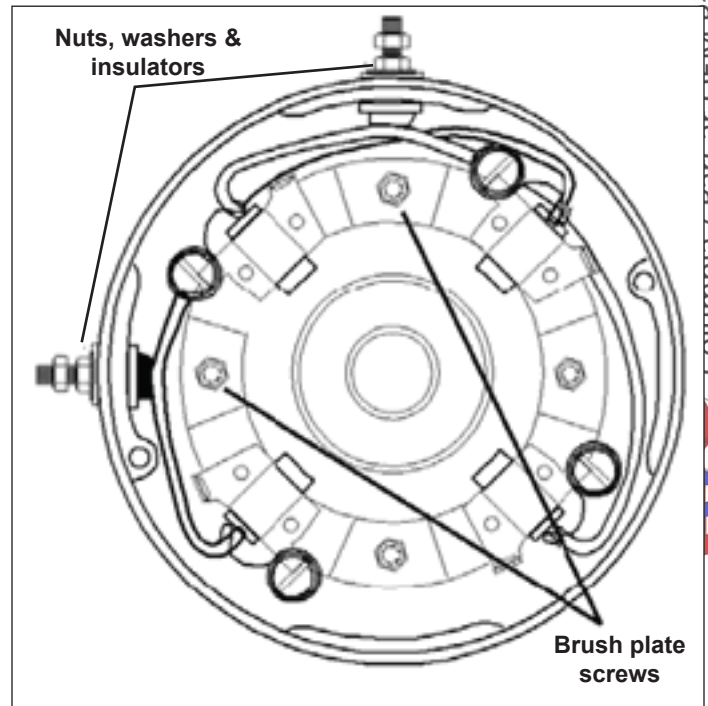


Figure 10-7. Brush Box and Brushes

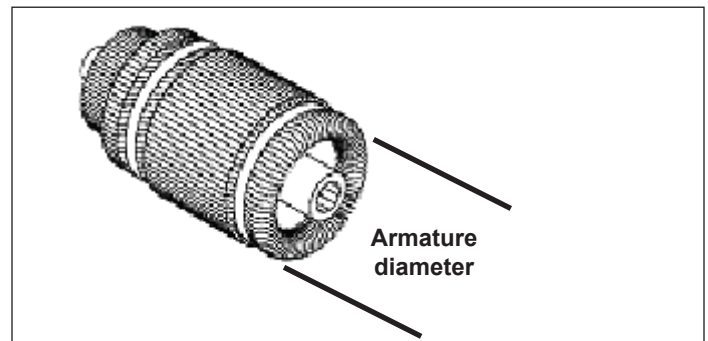
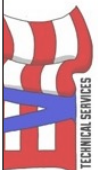


Figure 10-8. Armature Inspection

Columbia ParCar OEM Parts  
evtechnicalservices.com



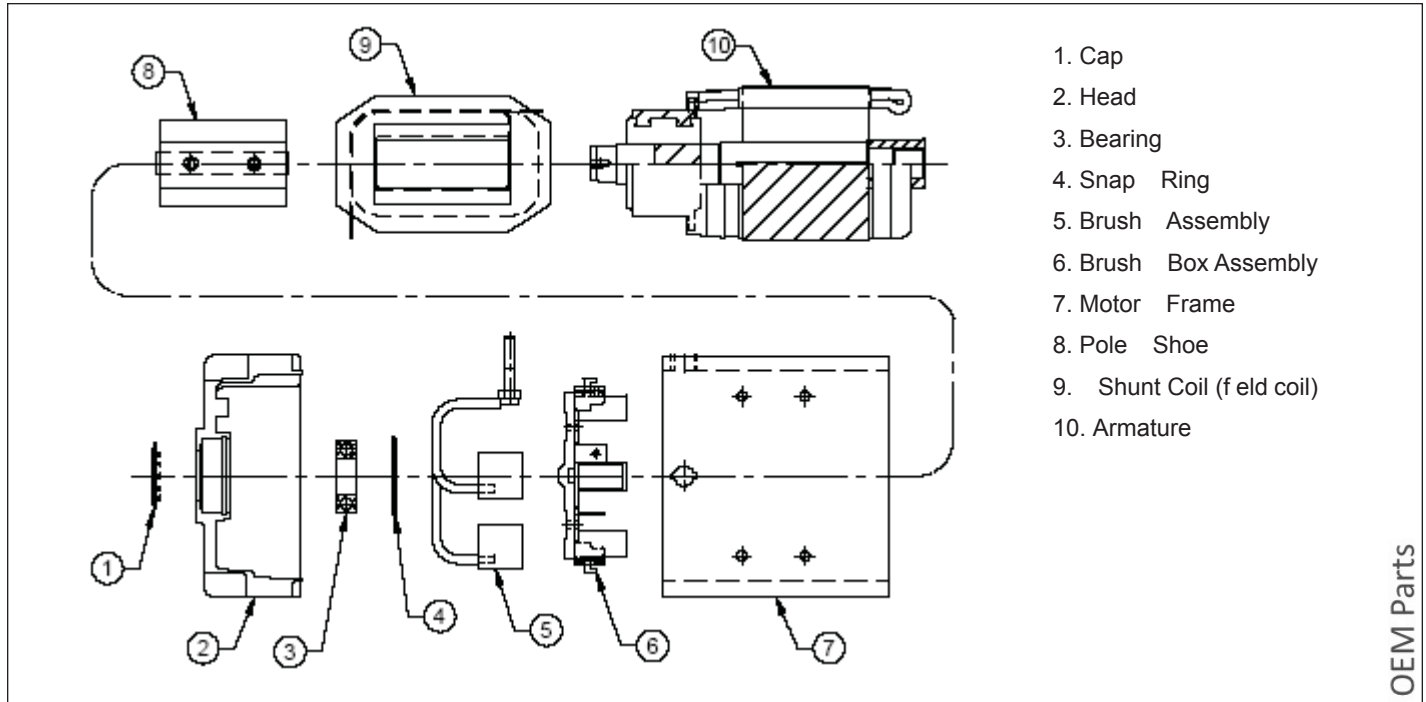


Figure 10-9. Traction Motor

Car OEM Parts

evtechnicalservices.com

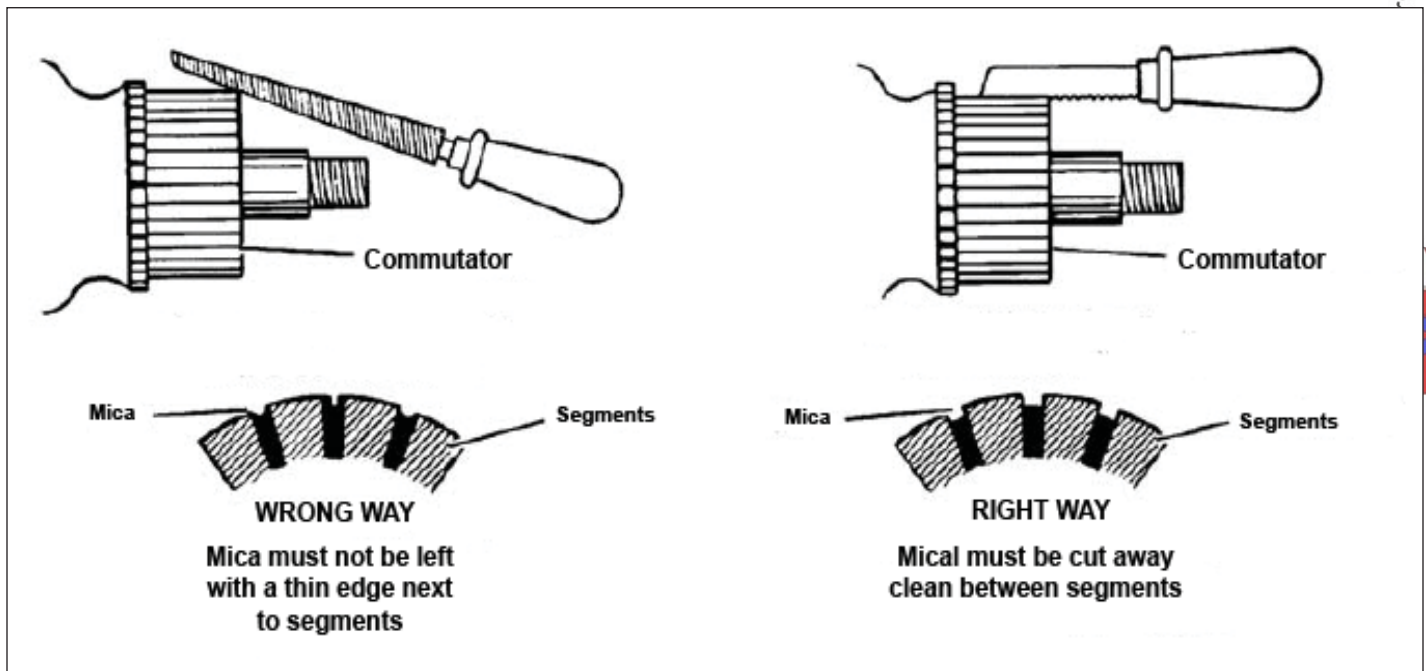


Figure 10-10. Undercutting the Armature

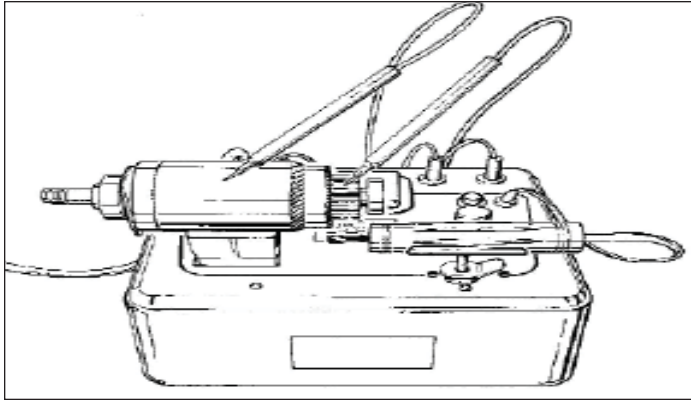


Figure 10-11. Checking Armature for Grounded Circuits

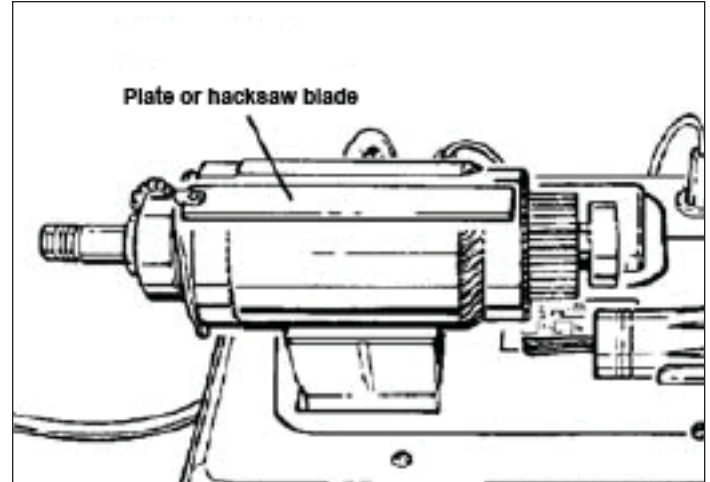


Figure 10-12. Checking Armature for Shorted Windings

### Bearing

After the motor has been disassembled, it is recommended that a new bearing be installed. Bearing may appear and feel ok, however, bearing may have been damaged during removal.

### Frame and Field Coils

#### NOTICE

**Do not remove the field coils (9, Figure 10-9), from the motor frame unless it is absolutely necessary for repair. Removal and re-installation could shorten field coil life.**

There should be no continuity between the frame of the motor and field coil (Figure 10-9). Set the volt ohm meter (VOM) to measure Ohms. See Figure 10-14.

### Field Coil Maintenance

NOT recommended by Columbia.

### Inspection

Motors that have been disassembled for servicing should also include a complete inspection of the frame and field assembly. It is not uncommon for the frame and field assembly of a motor to become exceptionally dirty after many hours of operation. This may result in a grounding condition due to dirt, grease and other foreign materials

### Traction Motor Reassembly

1. Always use a new bearing when reassembling a motor Press bearing into motor head. Press only against the outer race. See Figure 10-15. Install snap ring to retain bearing. Figure 10-16.
2. Assemble brush assemblies into brush box assembly.
3. Position brush holder into motor head as shown in Figure 10-16. Make sure that the terminals for the brushes are loose and free.
4. Install insulators and brush leads into motor head. See Figure 10-17. Brush motor terminals, A1 and A2, should be torqued to 140 in. lbs. (15.8 Nm).
5. Pull back each brush in it's holder, allowing the spring to rest against the side of each brush. This will hold each brush in

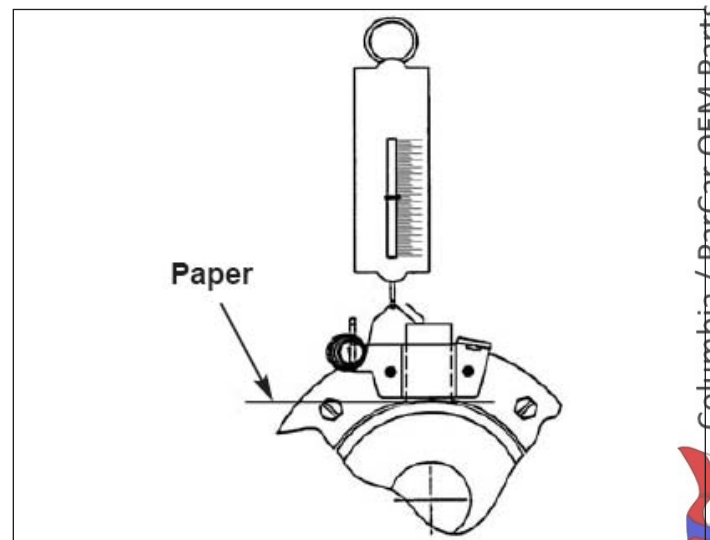


Figure 10-13. Brush Spring Pull Test

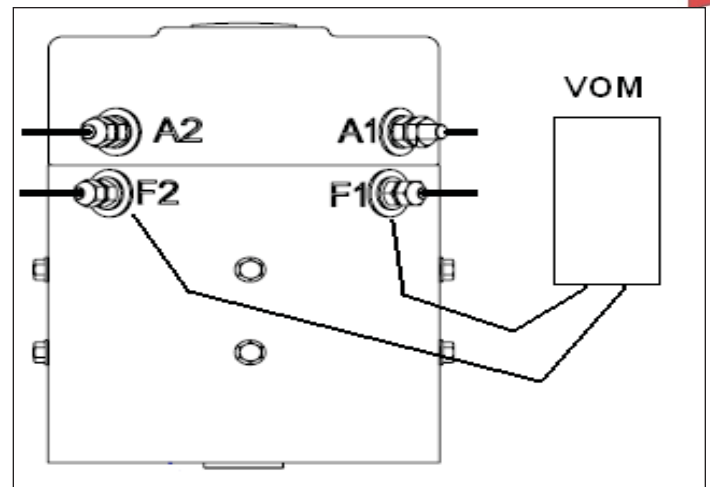


Figure 10-14. Testing for Continuity Between Motor Frame and Field Coil

Columbia / ParCar OEM Parts  
evtechnicalservices.com  
TECHNICAL SERVICES



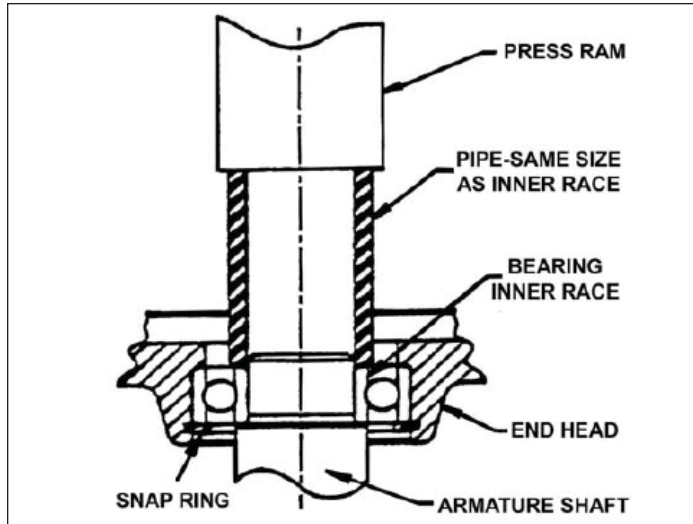


Figure 10-15. Press Bearing and End Cover onto Assembly

place, preventing interference and damage to commutator and brushes during armature installation.

6. Press motor head and bearing onto armature, pressing only against inner race of the bearing. See Figure 10-15.
7. Check that head and bearing rotates freely, without noise or irregular interference. Press brushes inward against armature commutator. Relocate the springs to push on the brushes. Check that brushes ride smoothly on the commutator.
8. Install motor head and armature assembly into field coil and frame assembly, aligning armature terminals to field coil terminals.
9. Install two bolts securing motor head to frame. Make certain motor head is completely seated to the frame before tightening. Torque bolts to 156 in. lb. (17.6 Nm).

### Traction Motor Installation

1. Coat open end of the armature and rear axle input shaft with Anti-Seize compound. Insert a new rubber bumper into open end of armature. Place motor into vehicle and onto input shaft.
2. Rotate motor to align mounting bolt holes to axle/differential housing. Install 3 bolts securing motor to rear axle/differential housing, while carefully supporting motor to prevent it from falling. Loosely tighten screws A and B, then loosely tighten screw C to draw face of motor up to flange on axle evenly (Figure 10-18). Torque screws A and B to 100 in. lbs. (11.3 Nm) Then tighten screw C to 100 in. lbs. (11.3 Nm).
3. Inspect electrical system cables for terminal identification (A-1, A-2, etc.). Position cables to traction motor, double checking wiring diagram to motor cable installation to ensure connections are correct.

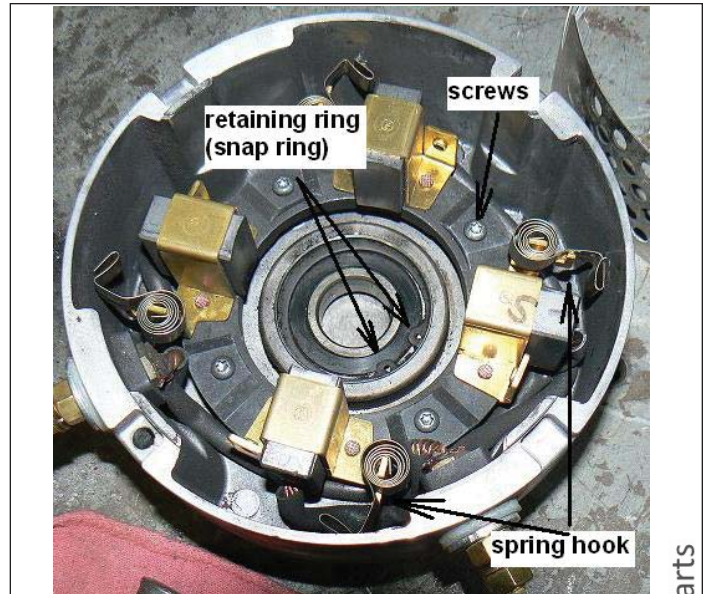


Figure 10-16. Spring Hooks for Brush Springs

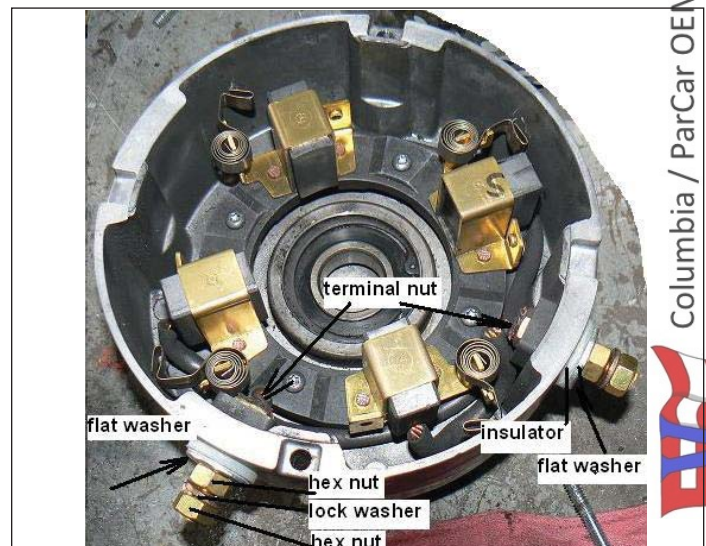


Figure 10-17. Brushes and Terminal Attaching Parts

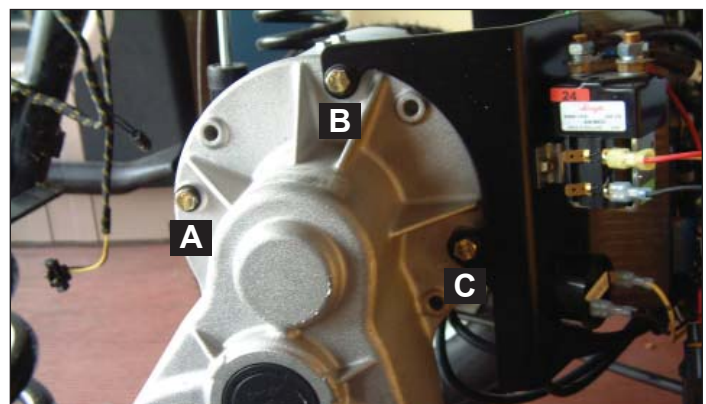


Figure 10-18. Motor Attaching Bolts





- F1 and F2 terminals are 1/4-20 UNC while A1 and A2 terminals are 5/16-18 UNC. Attach cables with flat washers, lock washers and hex nuts.

Torque A1 & A2 cable attaching nuts to 110 in. lbs. (12.4 N m), while holding the bottom nut, with a thin open-end wrench. Torque F1 & F2 cable attaching nuts to 50 in. lbs. (5.7 Nm), while holding the bottom nut, with a thin open end wrench.

- Place vehicle on the ground or onto dynamometer to test motor operation.

**CAUTION**

Do not run motor at full voltage without a load.

**CONTROLLER**

**Smartdrive Traction Motor System**

The Smartdrive system uses separately excited motor and Sevcon Controller with solid state forward/reverse control and plug braking. Plug braking is non-regenerative power absorbing deceleration. This system is better suited for flat terrain and reduced braking requirements. The Smartdrive system is distinguished by a 5 post controller.

**ACEplus Traction Motor System**

The ACEplus System is an advanced traction drive system that uses a fully integrated, solid state Sevcon Controller for speed regulation and forward/reverse control. Combined with a separately excited DC motor, the system provides optimized power efficiency through pedal proportional speed control and regenerative braking. This control system is ideal for hilly terrain or areas with multiple ramps. It is also used for towed loads and high braking demands. The ACEplus system is distinguished by a 6 post controller. See Figure 10-21.

**Controller Testing**

Do not remove the controller. It can be tested while still in the vehicle.

- Look for the steady green light on the controller. If it is on, the system is OK and ready (Figure 10-23).
- If it is flashing, count the number the flashes in each sequence. Refer to Section 4 - Troubleshooting for controller flash troubleshooting info, and for info on testing controller with Sevcontrol Calibrator or PC Pak computer interface.
- If the tests indicate that the controller has failed, replace it.

**Removing the Controller**

- Label/mark controller cables with controller terminal identification, if not already labeled. See Figures 10-20 & 10-21.

**NOTICE**

The controller terminal bolts and washers are Metric. Metric wrenches are required to remove the controller cable fasteners. The fasteners that attach the controller to the vehicle frame are SAE U.S.

- Smart drive: Remove five Metric bolts, lock washers and flat washers at controller terminals. Remove all electrical cables.

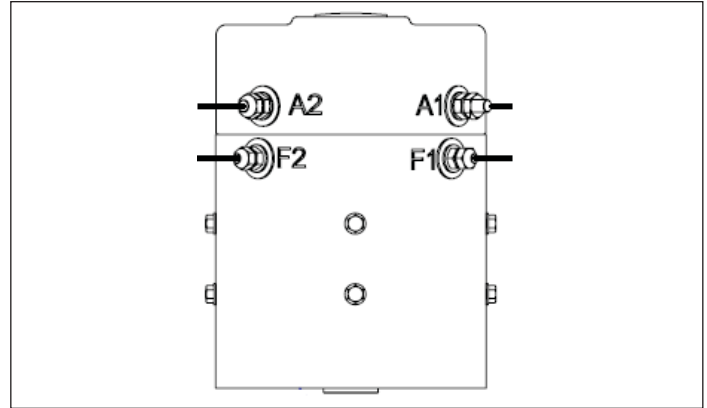


Figure 10-19. Traction Motor Cables Labels

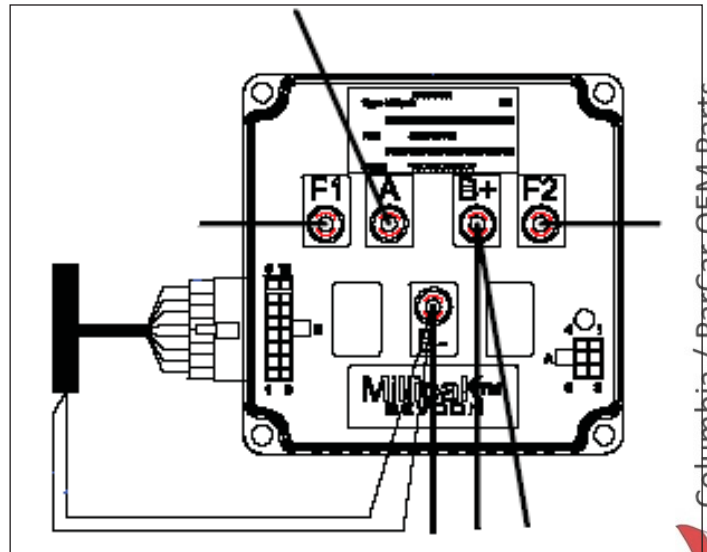


Figure 10-20. 5 Post Smartdrive Controller

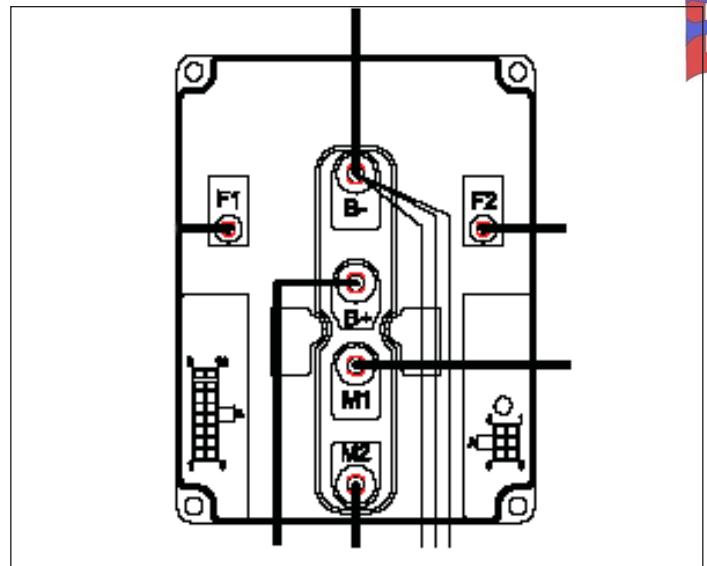


Figure 10-21. 6 Post ACEplus Controller

ACE plus: Remove six metric bolts, lock washers, flat washers and all the cables and wires connected to the controller.

- Remove 16 pin controller connector at port B in the lower left hand corner of the controller (Figure 10-23). See *Columbia Service Bulletin 06-010* if the wiring harness or connector are damaged.
- Remove four nuts, washers and bolts securing controller to mounting plate. See Figure 10-23.

**NOTICE**

**Do not attempt to disassemble the controller . There are no repairable parts inside.**

**Installing the Controller**

- Position new controller to mounting bracket. Secure controller with four bolts, washers and nuts (5). Figure 10-23.
- Install cables to controller terminals according to schematic, and to cable identification labels. Make sure there is a flat washer under the terminal ends of the cables. This will spread the load and help prevent the terminal ends from folding over. See Figures 10-21 and 10-22.

Sometimes a cable terminal end has been replaced and the bolt hole may be too big for the flat washer. Install a bigger flat washer to help prevent the oversize terminal end from folding over.

- Torque controller cable attaching bolts to 50 – 60 in. lbs. (5.7 – 6.8 Nm).
- Reconnect battery negative cable. Insert Power key in switch.
- Check for steady green light on new controller.
- Perform an operational check of the vehicle's driving abilities.

**CONTACTOR/SOLENOID**

This solenoid is an electro-magnetic switch that energizes when current is applied to the small control circuit terminals. When energized, the solenoid core moves up from magnetism created by the coil and internal contacts, creating a connection between two large terminals, allowing current to pass through the solenoid.

When control circuit voltage is removed from the small terminals, the magnetic field collapses and a spring returns the core to its rest position. A single contact solenoid in the normal position has an open circuit between the large terminals, preventing current from passing through it.

Solenoids are mounted in vertical position. Gravitational pull aids internal spring in returning to normal position.

**Removing the Contactor**

- Label contactor cables with terminal identification. Refer to schematic for correct wire numbers.
- Remove two nuts, washers and cables from stud terminals (Figure 10-24).
- Remove control circuit wires from spade terminals.

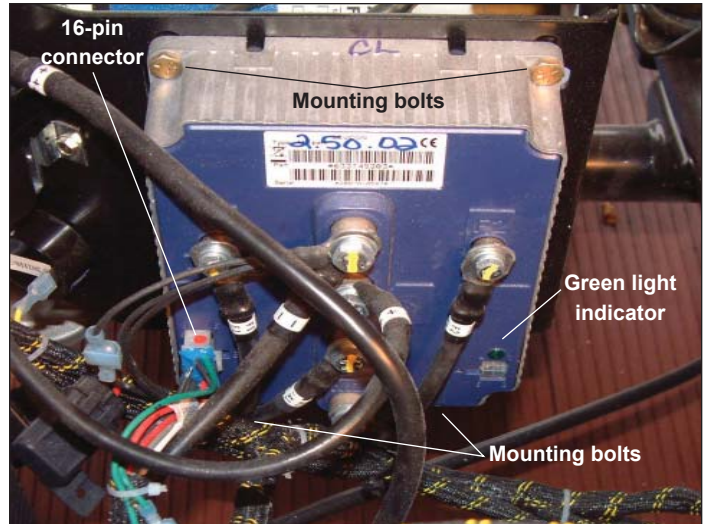


Figure 10-23. Controller Mounting (6 Post Shown)

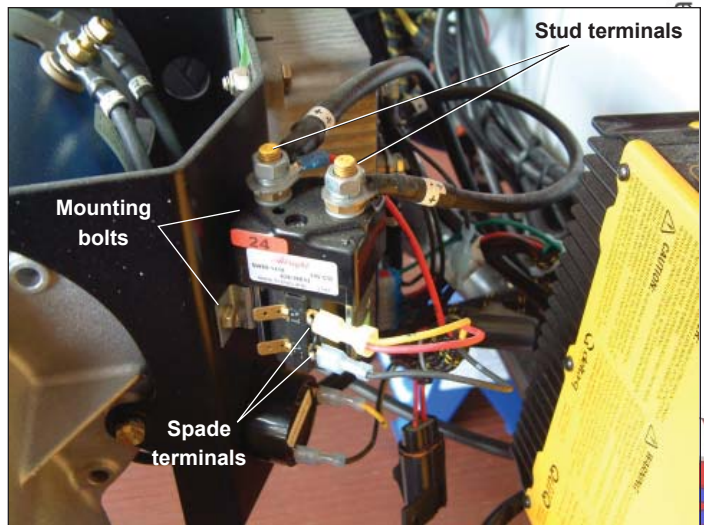


Figure 10-24. Contactor Connections

- Remove two nuts, washers, bolts and contactor (Figure 10-24).

**Installing the Contactor**

- Position new contactor to mounting bracket (Figure 10-24).
- Secure contactor to mounting plate with two bolts, nuts and washers.
- Install heavy cables to stud terminals. Install control circuit wires to spade terminals (Figure 10-24). Double check wiring diagram to ensure connections are correct.
- Operational Check: Contactor should emit an audible click when the power key switch is set to ON position.

This page intentionally left blank.



A member of the Nordic Group of Companies  
1115 Commercial Avenue, Reedsburg, WI 53959  
Phone - 608.524.8888 Fax - 608.524.8380  
[www.parcars.com](http://www.parcars.com)



Columbia / ParCar OEM Parts  
[evtechnicalservices.com](http://evtechnicalservices.com)