

SR

Series

For SR, SR-H,SRA,SF

使 用 手 冊

Instruction Manual

SCREW REFRIGERANT COMPRESSOR

螺旋式冷媒壓縮機



復盛股份有限公司
Fu Sheng Industrial Co., Ltd.

M-SR-EC1-9412

目錄 CONTENTS

前言 PREFACE.....	3
I.螺旋式冷媒壓縮機介紹	
INTRODUCTION TO SCREW REFRIGERATION COMPRESSOR	3
1.機體結構 STRUCTURE.....	4
1.1 機殼 Casing	4
1.2 轉子 Rotors.....	4
1.3 軸承 Bearings	4
1.4 進氣濾清器 Suction filter.....	4
1.5 油過濾器 Oil strainer	5
1.6 驅動馬達 Driving motor	5
1.7 油分離器 Oil separator.....	5
1.8 容調控制及容調電磁閥 Capacity control and solenoid valves.....	5
2.容調系統 CAPACITY CONTROL SYSTEM.....	7
2.1 四段式容調 Four steps capacity control	7
2.2 無段容調 Linear capacity control	12
II.螺旋式冷媒壓縮機規範	
SCREW REFRIGERATION COMPRESSOR SPECIFICATION	16
1.產品規範 PRODUCT SPECIFICATION.....	16
2.安裝與試車規範 INSTALLATION AND COMMISSIONING SPECIFICATION	17
2.1 壓縮機安裝 Install the compressor	17
2.2 運轉前注意事項 Items to be checked before startup	21
2.3 運轉中注意事項 Notices in operation	22
2.4 機組出廠運轉注意事項 Notices during factory test	23
2.5 壓縮機 ON/OFF 控制建議 Recommended control sequence of compressor ON/OFF	23
3.運轉規範 OPERATION SPECIFICATION	24
3.1 運轉規範 Operation range.....	24
3.2 運轉限制 Operation limitation	24
3.3 運轉電源 Power supply quality	24
3.4 運轉安全裝置 Safety device in operation.....	25
4.電氣規範 ELECTRIC SPECIFICATION	26
4.1 電氣結線方式 Electric wiring configuration.....	26
4.2 啓動程序 Start-up process	27
4.3 進相電容使用注意事項 Notice when using phase-leading capacitor	27

4.4 無熔絲開關(NFB)之選用 NFB selection.....	28
4.5 電磁氣接觸器 MC 之運用 Magnetic contactor(MC) selection.....	28
4.6 電氣資料 Electrical data.....	29
5.故障分析與保養週期 TROUBLE SHOOTING AND MAINTENANCE PERIOD.....	33
5.1 故障分析與研判 Trouble shooting	33
5.2 保養週期建議表 Recommended maintenance period	35
5.3 壓縮機馬達燒毀之處理 When the motor is burnt out	36
5.4 PUMP DOWN 注意事項 Notices on pump-down	36
6.應用 APPLICATION	36
6.1 液噴射 Liquid injection	36
6.2 油冷卻器 Oil cooler	40
6.3 儲冰空調 Thermal storage system and oil cooler.....	42
6.4 節能器 Economizer	42
7.產品內容 PRODUCT SCOPE	44
7.1 配件規格 Fittings specification	44
7.2 配件明細 Fittings list.....	45
7.3 潤滑油 Lubricant.....	46
7.4 噪音值 Noise level	47
7.5 尺寸圖 Dimension diagram.....	48
7.6 運轉範圍 Range of operation	56

前言

復盛公司所生產的螺旋式冷媒壓縮機，從製冷空調到冷凍冷藏系統，都是各種應用的最佳搭配。為配合各地區眾多客戶的需求，特別開發出 SR(H)、SF(A)與 SRA 系列，以符合客戶的使用工況與應用場合，最佳化產品性能，符合綠色環保高效率之需求。在歷經客戶多年的使用與磨練，我們所生產的壓縮機已獲得國內外各機組廠家的肯定與讚賞，並榮獲多項國內外產品認證與品質認證，例如：美國實驗室國家認證 UL、歐盟安全法規認證 CE mark、歐盟壓力容器認證 PED、ISO 9001 國際品質認證、臺灣精品獎等。此外，更針對目前日益嚴苛的能源效率法規，開發出滿液式專用機 SF(A)系列，以符合客戶真正的需求與節約能源的使命。

復盛公司為在冷凍空調業更上一層樓，不惜投入更多資金，引進最新式的螺旋轉子加工研磨機與三次元精密量床，為的就是要製作出更高品質、高效率的螺旋式冷媒壓縮機，以讓客戶得到百分百的滿意度為期許。並始終以持續改善為宗旨，「持續為客戶提供更具競爭力、性能更優越、品質可靠的螺旋式冷媒壓縮機。並期待在未來與客戶一同成長茁壯。

我們為確保客戶能夠順利的啓用復盛螺旋式冷媒壓縮機，特別在本使用手冊中，編寫有關 SR(H)、SF(A)與 SRA 系列在操作、使用或保養維修所應注意的各項要點與內容，以確保客戶權益。在此，特別提醒您，在安裝使用復盛螺旋式冷媒壓縮機之前，請先仔細閱讀本使用手冊，並確實遵守本手冊所敘述的注意事項與使用規範。如果您還有不明白之處或是額外需求的特殊使用條件，可與我們公司聯絡；或是您在使用上需要我們協助，我們都將即時為您提供解答與服務，以符合您的期待。

PREFACE

From air conditioning systems to refrigeration systems, Fu Sheng Co., Ltd. produces wide varieties of screw refrigerant compressors that are the best combination for various application systems. In order to meet demands for various working condition from clients, we have particularly developed the SR(H), SF(A) and SRA series of products to satisfy each client's unique application condition and design specification leading to their optimized chiller performance and conformity to the environmental protection requirement of high energy efficiency ratio. After years of practice and working with clients, our compressors have acquired numerous appreciations from various domestic and international institutes; such as the UL(USA), CE mark(EU), PED(EU), ISO 9001 and "Symbol of Excellence" Award (Taiwan), etc. Moreover, in response to the stricter energy efficiency codes, we have launched the SF(A) series exclusively for flooded chillers to meet client's real demand and the prospect of energy-saving.

In order to satisfy our client's prospect of compressors with high quality and efficiency, Fu Sheng Co. has invested significant resources to introduce the state-of-art screw rotor grinding machines and coordinated measuring machines in the production process. Our motto is to provide our value customers screw refrigerant compressors bearing with better competitive edge, performance and quality to earn satisfactions from customers and continue exceeding their expectations.

This instruction manual is prepared to ensure that users can operate or install Fu Sheng screw refrigerant compressors correctly. It covers the product lines of SR(H), SF(A) and SRA series. Reader will find information about the basic instruction of screw compressor, the principle of compressor operation, trouble shooting, and limitation of operation. Please read this manual carefully and follow the notes and specification illustrated in this manual before operating this equipment. Should you have any questions or need any help, please do not hesitate to contact us. We will provide you with assistance and answer that will meet your demand.



I. 螺旋式冷媒壓縮機介紹

1. 機體結構

1.1 機殼

機殼為螺旋式冷媒壓縮機之主體。內部支撐各項重要零件，包括：轉子、軸承座、容調滑塊……等各種元件。機殼是以精密之 M/C 加工機加工，與三次元精密量測儀確認加工精度，以確保壓縮機之間隙與精度能夠符合高效率運算的要求。採用高級灰口鑄鐵製之雙層式機體設計，除了符合耐壓要求外，更有降低噪音之功能。此高強度、高剛性之設計，使復盛之壓縮機可長期運轉無虞。

1.2 轉子

復盛採用榮獲多國多項設計專利新式的 5-6 非對稱轉子齒型，並由特殊高精度之轉子研磨機加工成形，精度佳，品質穩定。在連續運轉狀況下，轉子可保持最佳間隙值，以達到最高效率之要求。

1.3 軸承

以高精度大框號的軸向與徑向軸承確實支撐公母轉子，穩定耐用。並配合優良油路與機構設計，有效提高軸承壽命。運轉中各軸承均有潤滑油以壓差方式注入，使軸承獲得充分之潤滑。

1.4 進氣濾清器

在壓縮機入口處裝設進氣濾清器，可以將系統中不潔之顆粒與異物過濾，以防止被吸入壓縮機內，造成馬達與轉子故障。為避免新系統中殘留少許焊渣與雜質，而影響到壓縮機的正常運轉，建議在新機運轉一段時間後，將此濾清器拆下清洗，以確保日後壓縮機的正常運作與壽命。

I. Introduction to screw refrigeration compressor

1. Structure

1.1 Casing

Casing is the major component of screw refrigerant compressor that holds the rotors, bearing seat, capacity-control slide block and other parts of compressor. To reach high operation efficiency, the casing is manufactured by precise machining centers and inspected by a coordinate measuring machine to make sure that the requested precision and clearance can be retained in the compressor. The double-layered design casing made by high strength cast iron not only can endure intensive high pressure but also reduce noise level while in operation. This high-strength and high-rigidity design make Fu Sheng compressor suitable for long-term operation without encountering any problem.

1.2 Rotors

Fu Sheng compressor adopts the latest patented asymmetric rotor profile (tooth ratio 5:6). The rotors are machined by advanced CNC grinding machine to reach their accuracy and quality. Under continuous operation, the rotors still keep their best clearance and achieve highest efficiency.

1.3 Bearings

High-precision large axial and radial bearings are selected to support the male and female rotors for long lasting life. With effective lubrication system, the bearing service life can be further extended. While the compressor is running, lubricant is injected into all bearings due to pressure difference.

1.4 Suction filter

Installed at the suction end of the compressor, the filter prevents foreign objects or contaminated particles from entering the compressor and guarantees the normal operation of compressor. It is recommended dismantling and cleaning the filter completely shortly after the commission of compressor to ensure the ongoing normal operation and prolong operating lifetime.

1.5 油過濾器

機殼之下方為冷凍油儲槽，設有油過濾器。進入容調活塞室、軸承與轉子之潤滑油皆經過濾淨化，以防止鐵屑異物進入容調室及軸承內，損壞機件。油過濾器須定期清理，以維持油路系統之暢通，尤其是系統首次裝機試運轉完成後，更須注意確實清理乾淨。

1.6 驅動馬達

高效率兩極三相 F 級絕緣感應式馬達，內置 PTC 熱敏電阻搭配 INT69 模組保護電機，精確監控壓縮機馬達的線圈溫度，以確保壓縮機的正常運轉；適合降壓啓動 (star delta) 及直接啓動。

1.7 油分離器

內置式油分離器，內部構造採三段濾油機構，配合高密度油濾網，達到最佳的油氣分離效果，效率高達 99% 以上。

1.8 容調控制及容調電磁閥

容調滑閥機構精準控制系統所需之容量調節。可選用四段式或無段式設計，控制壓縮機的容量調節。並可配合多種內建式容積比，應用於各種不同冷媒不同工況，以作最高效率的運轉。

1.5 Oil strainer

Oil strainer is located in oil tank under the compressor casing. Any oil that passes through piston chamber, bearings and rotors must be filtered and purified in order to prevent foreign objects or steel chips from entering and causing damages to the parts. Oil Strainer must be cleaned regularly to keep oil channel clean, especially after the initial commission of compressor.

1.6 Driving motor

With the high-efficient two-pole, three-phase, class F inductive motor, built-in PTC thermistor and incorporated INT69 electrical-protection module to monitor the winding temperature of compressor motor closely, the compressor is insured under normal running. It's suitable for both star- delta or direct-on-line start-up.

1.7 Oil separator

The internal of built-in oil separator utilizes three-stage filter mechanism with high-density filter element to achieve optimal oil separation effect and its efficiency can be over 99%.

1.8 Capacity control and solenoid valves

The capacity control sliding valve mechanism accurately controls the required refrigerant flow responding to the system loading variation. The compressor provides four steps capacity control as a standard. The linear capacity control is also available as an option. For special operation conditions, there are various built-in volume ratios to be adopted. This leads to high energy efficiency.

機體結構圖

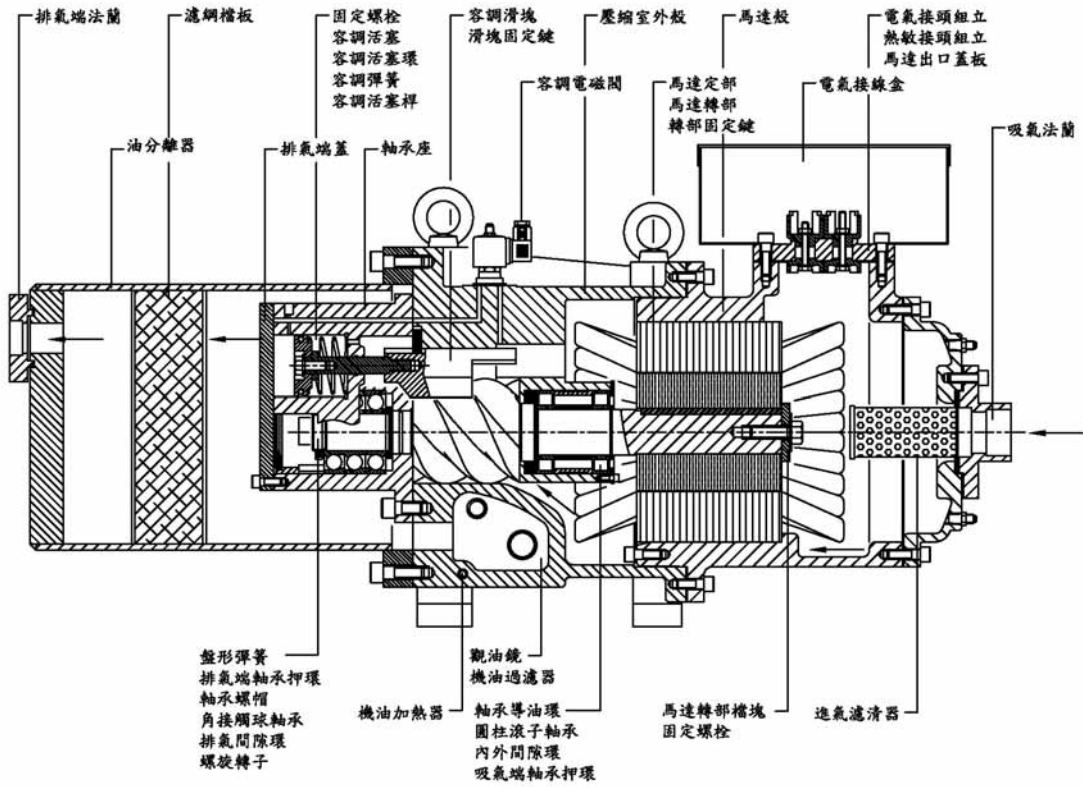

Compressor structure

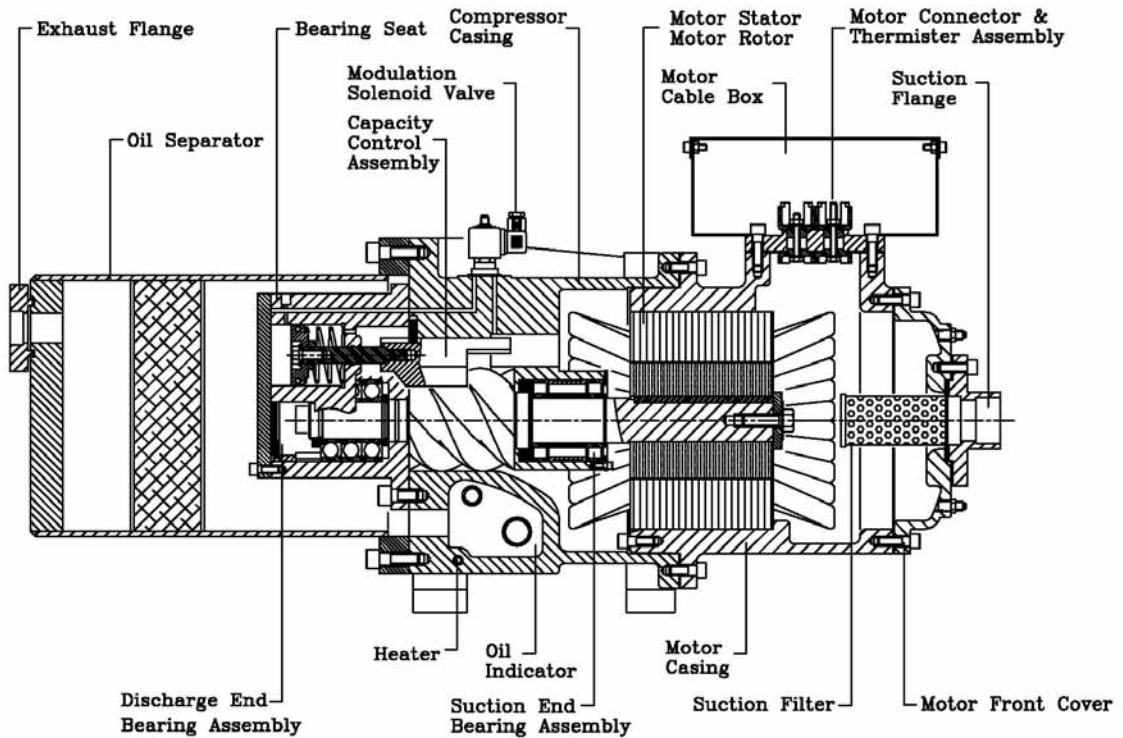

2.容調系統

2. Capacity control system

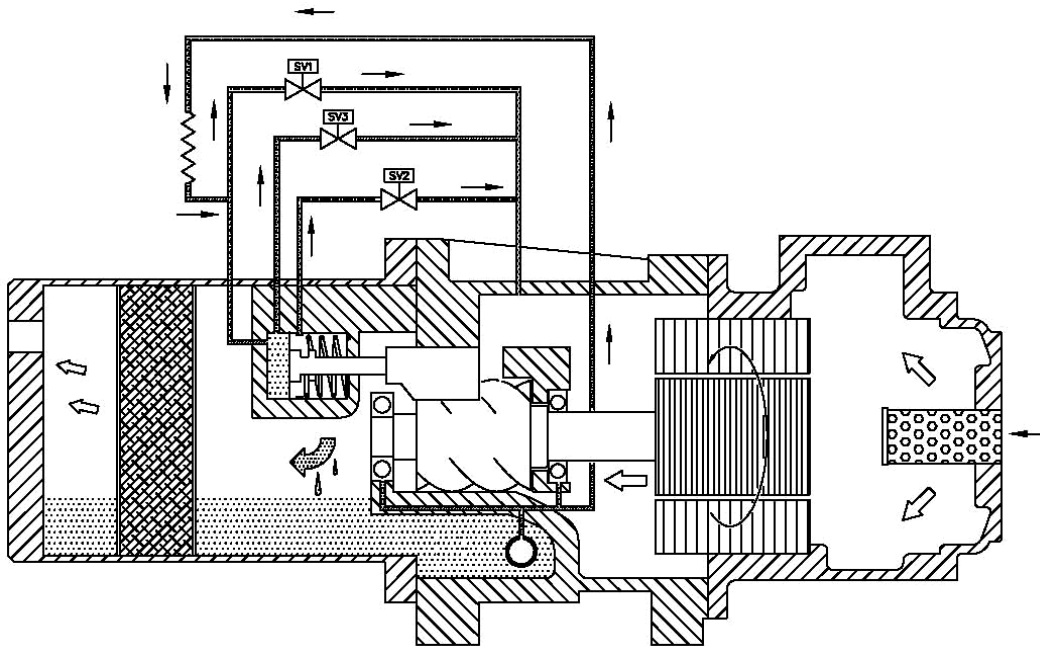

容調與潤滑油路圖

Capacity control & oil circulation diagram

2.1 四段式容調

四段式容調系統由一個容調滑塊、三個常閉(NC)電磁閥與一組容調活塞組成，可調節的範圍有 25%、50%、75%、100%。其原理系利用活塞帶動容調滑塊，當部份負載時，容調滑塊移動將部份冷媒傍通回吸氣端，使冷媒流量減少以達到部份負載之功能。當停機時，彈簧的力量使活塞復歸到起始狀態。壓縮機運轉時油壓開始推動活塞，借著電磁閥之作動，控制油壓活塞的定位，而電磁閥則由系統之回水溫度開關來控制。控制容調活塞之油從機殼之油儲槽中，以壓差方式送入，經油過濾器後以毛細管限流再送入油壓缸；若油過濾器阻塞或毛細管阻塞將造成容調系統作動不順或失敗；同樣若電磁閥故障，亦有相同之情況發生。

2.1 Four steps capacity control

The principle of capacity control is by moving the slide block to allow partial refrigerant to bypass back to the intake and regulate the refrigerant flow. The 4-step capacity control system is made of one slide block, three NC solenoid valves and one piston with adjustable range of 25%, 50%, 75% and 100%. When the compressor shutdown, the spring force brings slide block back to the initial position. When in operation, the hydraulic pressure pushes the piston to move to the direction of increasing loading. The exact position of piston and slide block is decided by the open/close of solenoid valve channel. The on/off of solenoid valve is controlled by temperature of return chilling water. The hydraulic oil is injected from the oil tank due to the pressure differential and then flows into hydraulic cylinder to move slide block. The oil flow-rate is regulated by a capillary tube after passing through the oil strainer. If the oil strainer or capillary tube is clogged, the capacity control system malfunctions. Same situation can be also caused by failed solenoid valves.

四段式容調電磁閥作動表

電磁閥 負載	SV1 (常閉)	SV2 (常閉)	SV3 (常閉)
100%	OFF	OFF	OFF
75%	OFF	ON	OFF
50%	OFF	OFF	ON
25%(啓動)	ON	OFF	OFF

OFF→不激磁; ON→激磁.

2.1.1 啓動運轉：25%負載

壓縮機在起動時，必須使負載降到最低才容易起動。所以 SV1 受電作動，油直接傍通回到低壓側，此時容調滑塊傍通空間最大負載只有 25%，待起動完成後，壓縮機才可以逐漸加載，一般起動 25% 負載運轉時間約設 30 秒左右。

Four steps control sequence of solenoid valve

Solenoid valve Status	SV1 (NC)	SV2 (NC)	SV3 (NC)
100%	OFF	OFF	OFF
75%	OFF	ON	OFF
50%	OFF	OFF	ON
25%(start)	ON	OFF	OFF

OFF→ de-energized; ON→ energized.

2.1.1 Startup: 25% loading

For easier startup of compressor, the loading must be minimized. Therefore, SV1 is energized to bypass oil to the low-pressure side directly. The slide block does not move and keep the maximum opening in suction end to bypass the refrigerant. After the completion of startup, the compressor can increase loading gradually by de-energizing the SV1 solenoid valve. It is recommended to run compressor at 25% loading for about 30 seconds before starting to increase loading.

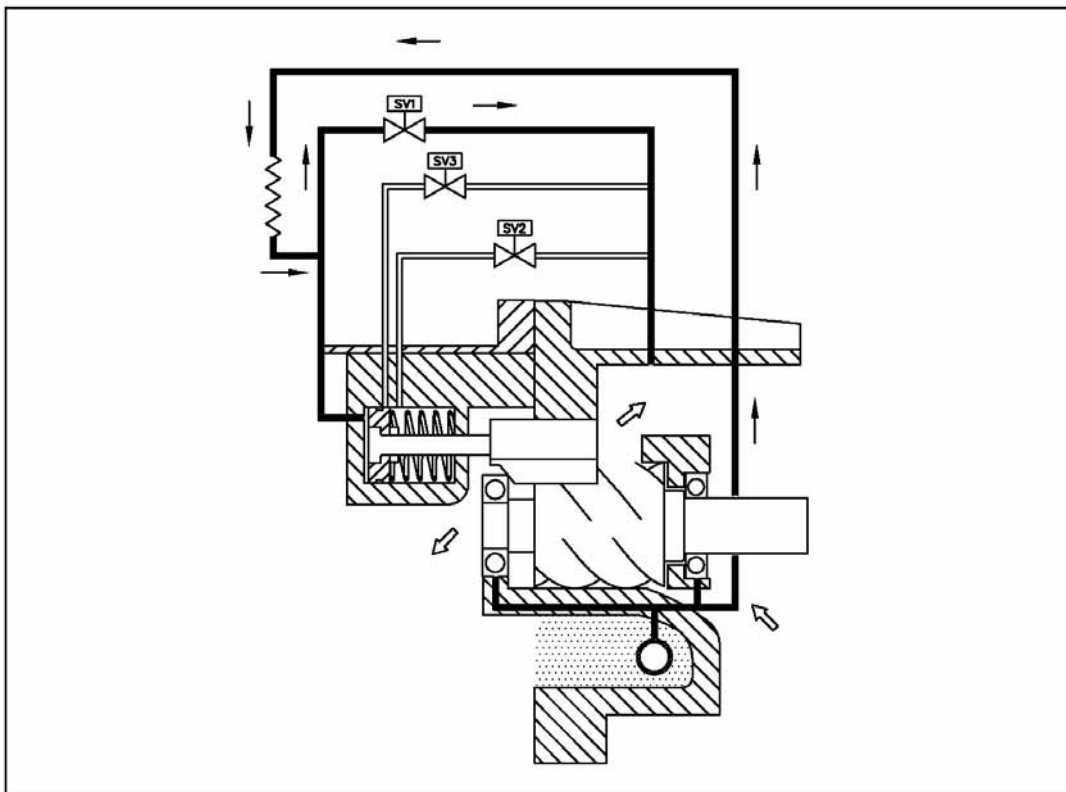

25%容調啓動流程圖
Flowchart of 25% loading (for startup)

2.1.2 部分負載: 50%運轉

依 25%相同之原理，SV3 受電作動，壓縮機即作 50%之負載運轉。

2.1.2 Partial load: 50% loading

With the same principle as stated in 25% loading, SV3 is energized and others are de-energized to achieve 50% loading

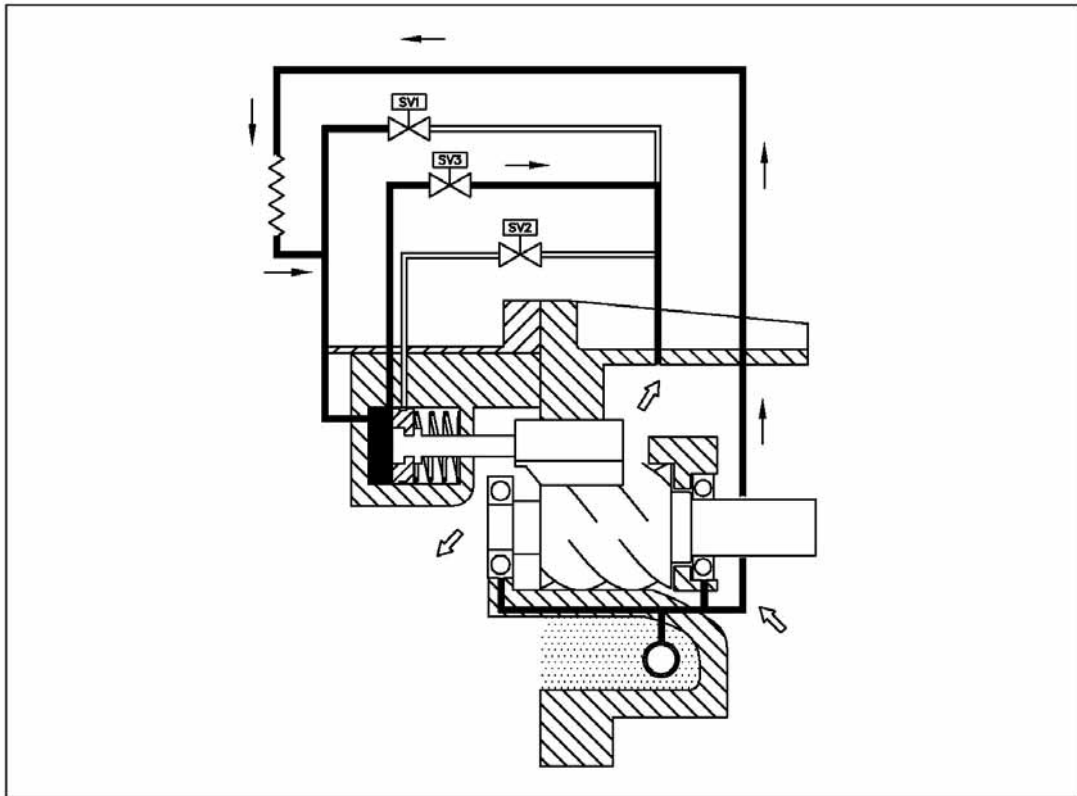

50%容調流程圖
Flowchart of 50% loading

2.1.3 部分負載：75%運轉

當系統設定之溫度開關作動，信號直接給電磁閥 SV2，SV2 受電，傍通打開，油即從此 SV2 傍通流至低壓側，活塞即因油路傍通之關係返到傍通口位置，容調滑塊傍通打開，部份冷媒從傍通回路回到低壓側，壓縮機排氣量減少，壓縮機 75% 負載運轉。

2.1.3 Partial load : 75% loading

Receiving a feedback from system demanding for lower capacity, the SV2 is energized to allow oil to flow back to the low-pressure side through the valve channel. The piston returns to the outlet of SV2 oil passage and the slide block moves to let part refrigerant flow back to the low-pressure side through bypass opening. This action would reduce the discharge volume and makes the compressor operating at 75% loading.

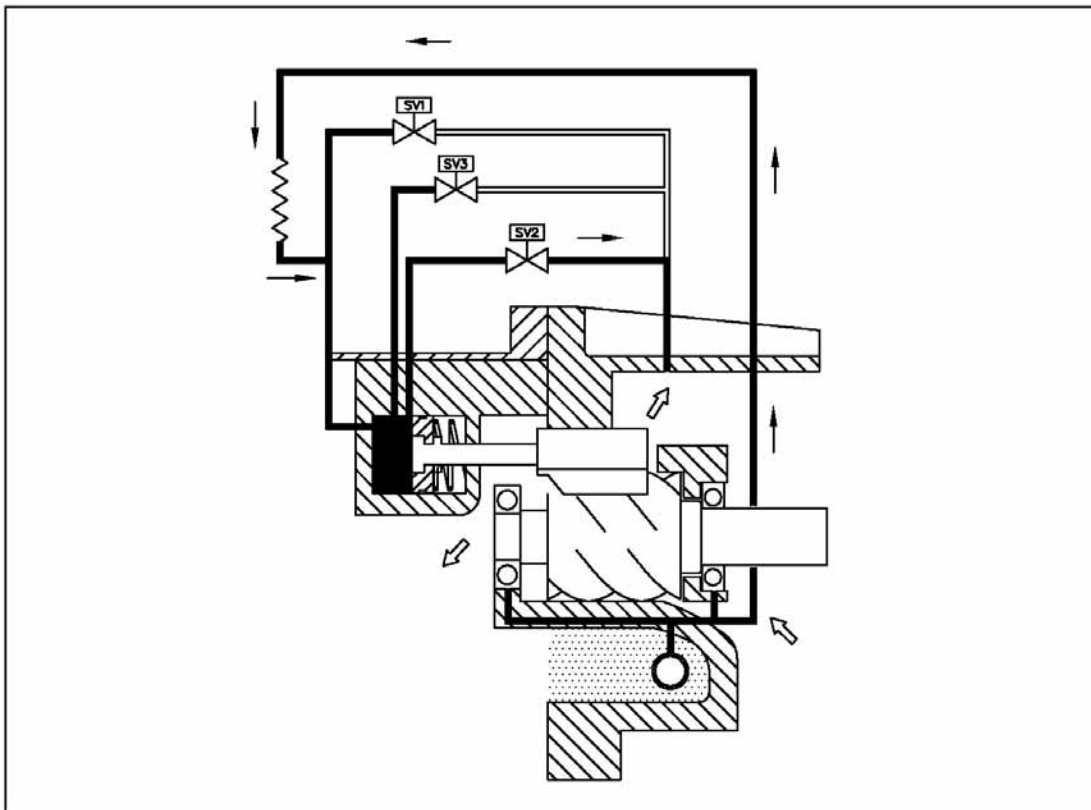

75% 容調流程圖
Flowchart of 75% loading

2.1.4 全載：100%運轉

壓縮機起動完成後，SV1,2,3 均不受電，油直接進入油壓缸內推動容調活塞向前，容調活塞帶動容調滑塊，使冷媒旁通逐漸減小，直到容調滑塊完全推到底，此時壓縮機全負載 100%運轉。

2.1.4 Full load: 100% loading

After the completion of startup, SV1, SV2 and SV3 are de-energized and oil flows straight to cylinder and pushes piston forward, driving the slide block to gradually reduce bypass opening. When the opening is closed completely, the compressor is running at 100% loading.

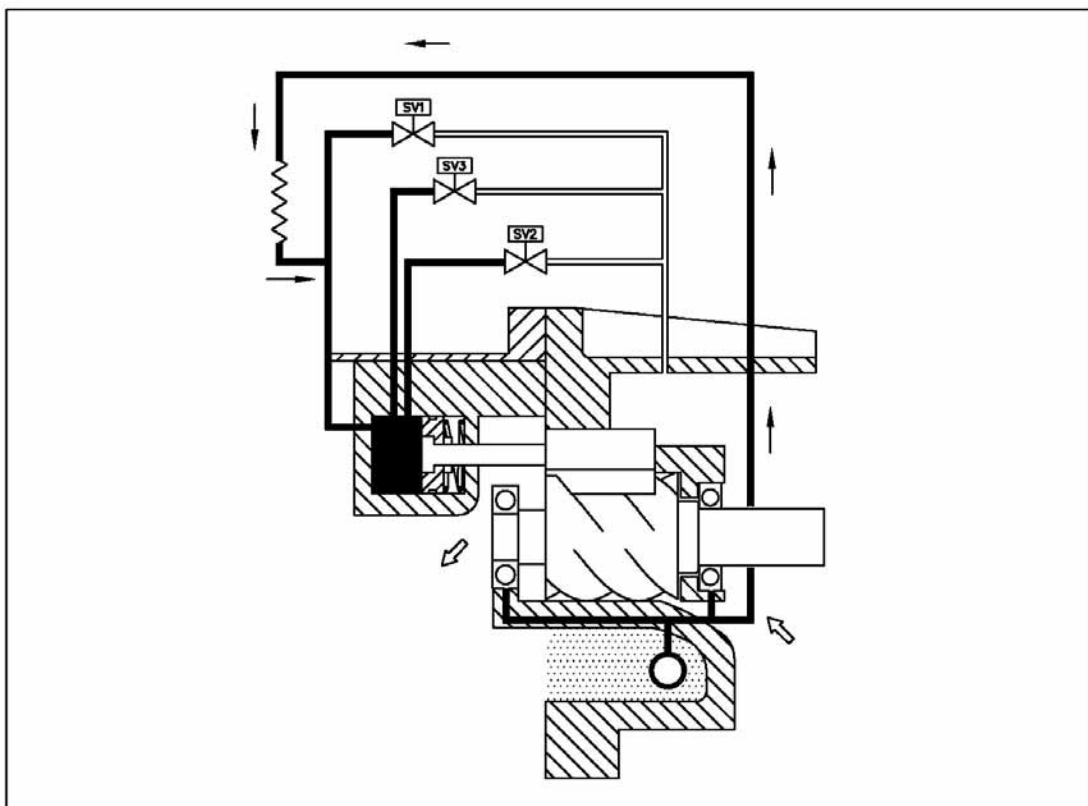

100%容調流程圖
Flowchart of 100% loading

2.2 無段容調

無段容調系統與四段式容調其基本原理相同，所不同者在於電磁閥之控制應用，四段式容調控制採用三個常閉電磁閥，無段式容調控制則採用一個常開電磁閥以及一或兩個常閉電磁閥，控制電磁閥的開關，以決定壓縮機之加載或洩載。

2.2.1 運轉範圍：25%~100%

利用一個常閉電磁閥 SV1(控制洩油通路)確保壓縮機在最低負載下進行啟動以及一個常開電磁閥 SV2(控制進油通路)，依負載需要控制 SV1 及 SV2 受電或不受電以達到容調控制效果，如此無段容調可在 25%~100% 容量之間作連續式控制以達到穩定輸出之功能。電磁閥控制作動時間建議在 0.1~0.5 秒左右，依實際狀況調整。

當壓縮機啟動時，SV1 需通電以便將液壓缸之冷凍油透過 SV1 油路，導回壓縮機之低壓端(SV2 斷電)，容調滑塊因內部彈簧之作用力，確保壓縮機在 25% 負載的位置，啟動之後所有電磁閥皆斷電，讓壓縮機加載到 100% 負載運轉。

在穩態時 SV1 持續斷電，SV2 則持續通電以維持穩定的冷凍能力輸出；當環境負荷變動時，控制 SV1 及 SV2 的通電與斷電，調整壓縮機輸出冷凍能力之大小，以符合環境的實際負荷需求；

當環境負荷增加時 SV2 短暫斷電，使得少量冷凍油能夠流入油壓缸，使得容調滑塊往增加冷凍能力的方向移動；當環境負荷減少時 SV1 短暫通電，使得少量冷凍油能夠經由 SV1 流出油壓缸，使得容調滑塊往減少冷凍能力的方向移動。

2.2 Linear capacity control

The main principle of linear capacity control system is the same as four steps one, except that the control logic of solenoid valve varies. The four-step capacity-control needs three NC (normal close) solenoid valves, whereas the linear one uses one NO (normal open) solenoid valve and one or two NC solenoid valves to control the increase /decrease of loading.

2.2.1 Capacity control range : 25%~100%

The compressor system uses one normal close solenoid valve SV1 (to bypass oil from cylinder) to guarantee that the compressor can start at the minimum loading and another normal open solenoid valve SV2 (to feed oil to cylinder). The system dynamically controls the energize/de-energize of SV1 and SV2; thus, the compressor output is continuously and linearly adjusted in a range between 25% and 100% loading, in response to the actual loading requirement. The recommended pulse time of solenoid valves is about 0.1-0.5 second and it shall be adjusted according to actual operating status.

When starting compressor, SV1 is energized to bypass the oil in hydraulic cylinder back to the low-pressure suction end while SV2 is de-energized. Slide block remains in its initial position due to the spring force and then the compressor can be sure to start at 25% loading. Once the startup process is complete, all solenoid valves shall be de-energized to increase the loading up to 100%.

To keep compressor running in steady state, SV1 is de-energized continuously but SV2 is energized to maintain the stable refrigeration capacity output. Once loading has been changed, the system controls the energize/de-energize of SV1 and SV2 to adjust output of compressor in order to fit actual loading requirement.

When loading increases, SV2 de-energizes shortly to allow small amount of oil flow into hydraulic cylinder, forcing slide block to move in the direction of increasing refrigeration capability. If loading decreases, SV1 energizes shortly to allow small amount of oil to flow out of hydraulic cylinder causing slide valve to move in the direction of decreasing the refrigeration capability.

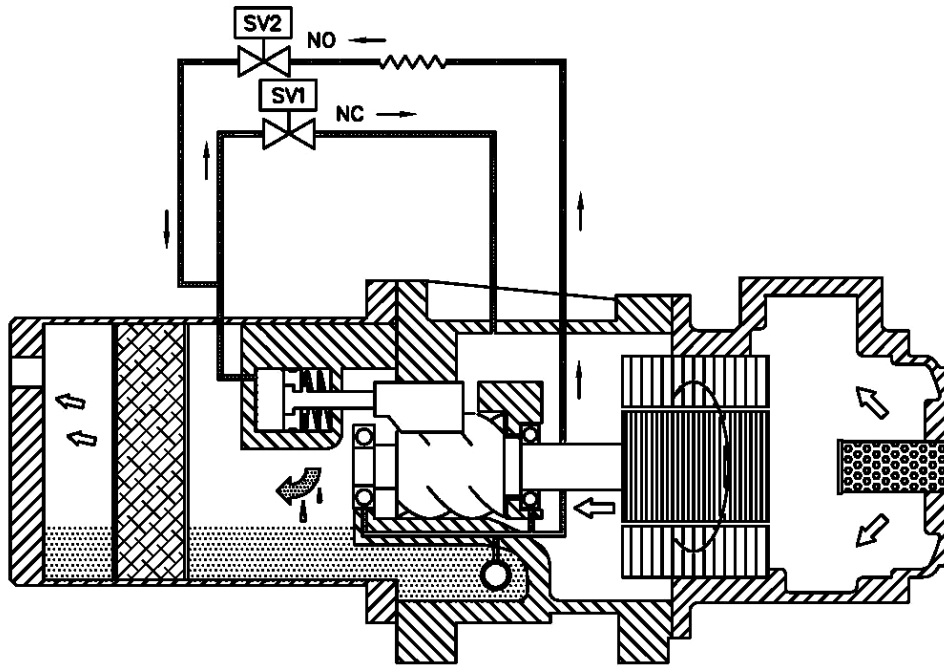

無段容調流程圖(25%~100%)
Flowchart of linear capacity control(25%~100%)

無段容調(25%~100%)電磁閥作動表

電磁閥	SV1 (常閉)	SV2 (常開)
負載		
啓動	ON	OFF
加載	OFF	OFF
卸載	ON	OFF
保持	OFF	ON

OFF→不激磁; ON→激磁.

Linear control sequence of solenoid valve
(25%~100%)

Solenoid valve	SV1 (NC)	SV2 (NO)
Status		
Start-up	ON	OFF
Loading	OFF	OFF
Unloading	ON	OFF
Holding	OFF	ON

OFF→ de-energized; ON→ energized.

2.2.2 運轉範圍：50%~100%

為防止冷媒壓縮機馬達長時間在低負載下運轉(25%)，可能造成馬達溫度過高或因膨脹閥能力過大造成液壓縮，在設計無段容調系統時將壓縮機最低容調限制在 50%負載以上。採用一個常閉電磁閥 SV1(控制傍通)確保壓縮機在最低負載下進行啓動；此外利用一個常開電磁閥 SV0(控制進油通路)及常閉電磁閥 SV3(控制洩油通路)限制壓縮機在 50%~100%範圍之間運轉，依需要控制 SV0 及 SV3 受電或不受電以達到容調控制效果，無段容調可在此容量範圍作連續式控制以達到穩定輸出之功能。電磁閥控制作動時間建議在 0.1~0.5 秒左右，依實際狀況調整。

當壓縮機以 25%啓動時，SV1 需通電以便將液壓缸之冷凍油透過 SV1 油路，導回壓縮機之低壓端 (SV0, SV3 斷電)，因此容調滑塊因內部彈簧作用力，維持在 25%負載的位置，.啓動之後 SV0, SV1 斷電 及 SV3 通電使得壓縮機在啓動時以 50%負載持續運轉 180 秒，然後所有電磁閥皆斷電，讓壓縮機加載到 100%負載運轉。

在穩態時 SV1, SV3 持續斷電，SV0 則持續通電以維持穩定的冷凍能力輸出；當環境負荷變動時，控制 SV0 及 SV3 的通電與斷電，調整壓縮機輸出冷凍能力之大小，以符合環境的實際負荷需求；當環境負荷增加時 SV0 短暫斷電，使得少量冷凍油能夠流入油壓缸，使得容調滑塊往增加冷凍能力的方向移動；當環境負荷減少時 SV3 短暫通電，使得少量冷凍油能夠由 SV3 流出油壓缸，使得容調滑塊往減少冷凍能力的方向移動。

2.2.2 Capacity control range: 50%~100%

To prevent the compressor from running at low-loading state (25%) which could lead to motor overheat or liquid compression due to oversized expansion valve, it is recommended to maintain the minimum operating capacity at 50% loading for linear capacity control. For startup, energize the SV1 (to bypass oil) to make sure that the compressor can be started at minimum loading. A normal-close solenoid valve SV0 is used to bypass oil from cylinder while SV3 to feed oil into cylinder. The compressor only operates between 50% and 100% loading by controlling the on/off of SV0 and SV3. The recommended pulse time of solenoid valves is about 0.1-0.5 second and it shall be adjusted according to actual operating status.

When the compressor starts in 25% loading, SV1 needs to be energized to bypass the refrigeration oil back to the low-pressure suction end of compressor from the hydraulic cylinder through SV1 oil channel (both SV0 & SV3 are de-energized); the slide block is maintained in 25%-load position due to internal spring force. After the startup of compressor, both SV0 & SV1 are de-energized and SV3 is energized to keep compressor running at 50% loading for 180 sec. After that, all solenoid valves are de-energized to increase compressor output to 100% (full load).

To keep compressor running in steady state, SV1, SV3 are de-energized but SV0 is energized to maintain the stable refrigeration capacity output. Once loading is changed, the system energizes/de-energizes SV0 or SV3 to adjust compressor output in order to fit actual loading requirement. When loading increases, SV0 is de-energized shortly to allow small amount of oil flow into hydraulic cylinder to force slide block to move in direction of increasing refrigeration capacity. If loading decreases, SV3 is energized shortly to allow small amount of oil flow out of hydraulic cylinder to let slide block to move in the direction of decreasing the refrigeration capacity.

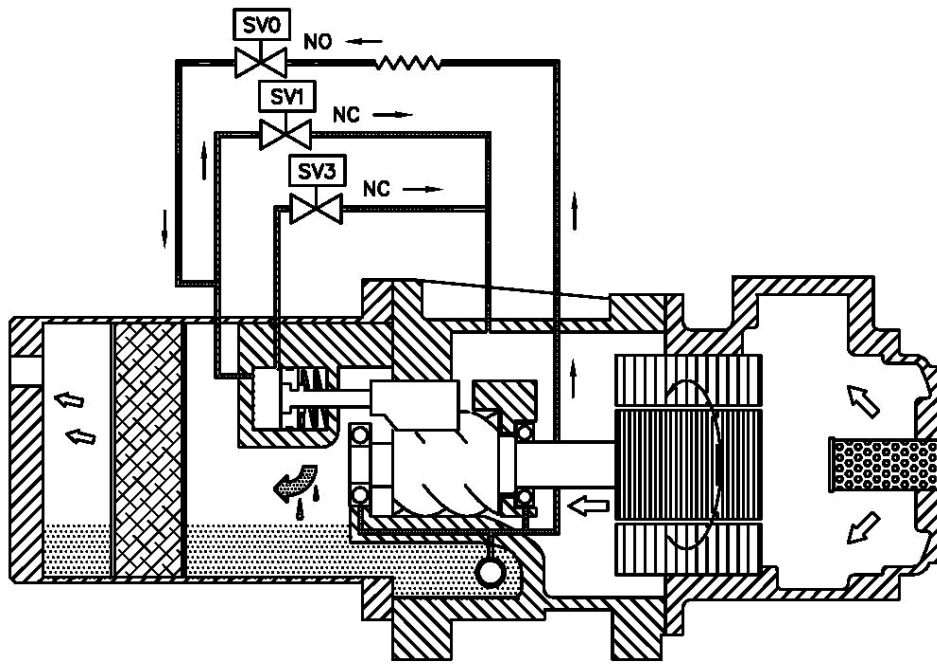

無段容調流程圖(50%~100%)
Flowchart of linear capacity control(50%~100%)

無段容調(50%~100%)電磁閥作動表

電磁閥	SV0 常開	SV1 常閉	SV3 常閉
負載			
啓動	OFF	ON	OFF
加載	OFF	OFF	OFF
卸載	OFF	OFF	ON
保持	ON	OFF	OFF

OFF→不激磁; ON→激磁.

Linear control sequence of solenoid
valve(50%~100%)

Solenoid valve	SV0 (NO)	SV1 (NC)	SV3 (NC)
Status			
Startup	OFF	ON	OFF
Loading	OFF	OFF	OFF
Unloading	OFF	OFF	ON
Holding	ON	OFF	OFF

OFF→ de-energized; ON→ energized.

II.螺旋式冷媒壓縮機規範

II.SCREW REFRIGERATION COMPRESSOR SPECIFICATION 1. PRODUCT SPECIFICATION

1.產品規範

機型 Model		SR-1(H)	SR-2(H)	SR-3(H)	SR-434(H)	SR-4(H)	SR-5(H)	SR-561(H)	SR-6(H)	SR-7(H)	SR-8(H)
		SRA-1	SRA-2	SRA-3	SRA-434	SRA-4	SRA-5	SRA-561	SRA-6	SRA-7	SRA-8
		SF(A)-50	SF(A)-60	SF(A)-70	SF(A)-90	SF(A)-120	SF(A)-140	SF(A)-160	SF(A)-180	SF(A)-230	SF(A)-270
變位量 Displacement	m ³ /hr	174/145	220/183	265/221	349/291	434/362	519/432	594/495	668/557	842/702	998/832
轉速 rpm	rpm	3550/2950									
容調控制範圍 Capacity control range	%	100/75/50/25(啓動)、無段式容量調節 100/75/50/25 (start), Linear capacity control									
冷媒 Refrigerant		SR(H)、SF 機型: R-22 / R407C SR(H), SF Model: R-22 / R407C					SRA、SFA 機型: R-134a SRA, SFA Model: R-134a				
潤滑方式 Lubrication		壓差給油 Differential pressure feeding									
型式 Type		3 相, 2 極, 感應馬達 3 ϕ . 2p induction motor									
啓動方式 Start Method		Y- Δ 啓動或直接啓動 Y- Δ start or D-O-L									
頻率 Frequency	Hz	60/50									
電壓 Voltage	V	220,380,440,460/380~400									
絕緣等級 Insulation Class		Class F									
保護裝置 Protection device		馬達線圈溫度保護器 PTC thermistor									
機油加熱器 Heater	W	150				300					
液壓試驗 Hydraulic test	bar	R407C/R22 : 42(高壓側) ; R134a : 29(高壓側) R407C/R22 : 42 (high-pressure side); R134a : 29 (high-pressure side)									
潤滑油填充量 Oil charged	Liter	9	11	11	13	13	13	13	19	23	23
重量 Weight	kg	420	520	530	630	930	930	930	1100	1150	1250
☆ 本公司保留設計修改權利, 恕不另行通知。 Fu Sheng reserves rights to change design without notice. ☆ SR(H)系列適用 R-22/R-407C, SRA 系列適用 R-134a, SF(A)適用 R-22(R-134a) 滿液式冰水機組。 SR (H) series for R-22/R-407C, SRA series for R-134a and SF (A) series for flooded type chiller application with R-407C/R-22 (R-134a).											

2.安裝與試俾規範

2.1 壓縮機安裝

2.1.1 運送

請用安全鋼索勾著壓縮機機殼上方之兩環首螺栓；或利用二條安全吊帶，環繞壓縮機機體，而將其吊起安裝。搬運或吊運途中請勿碰撞壓縮機機體，尤其是機體上所安裝之零組件(例如：毛細管、輸油銅管、電磁閥、洩油閥、銅接頭、接線盒組等)，並保持水平，嚴禁重落地。

2. INSTALLATION AND COMMISSIONING SPECIFICATION

2.1 Install the compressor

2.1.1 Delivery

Use the two eyebolts attached to compressor body for hoisting purpose or two safe belts to wrap around the compressor body and hoist it up. Do not crash the compressor body during the transporting or hoisting process especially those parts assembled on compressor (ex. capillary tube, copper oil tube, solenoid valves, drainage valve, copper connectors, and terminal box, etc). Keep the compressor body leveled and avoid severe ground impact.

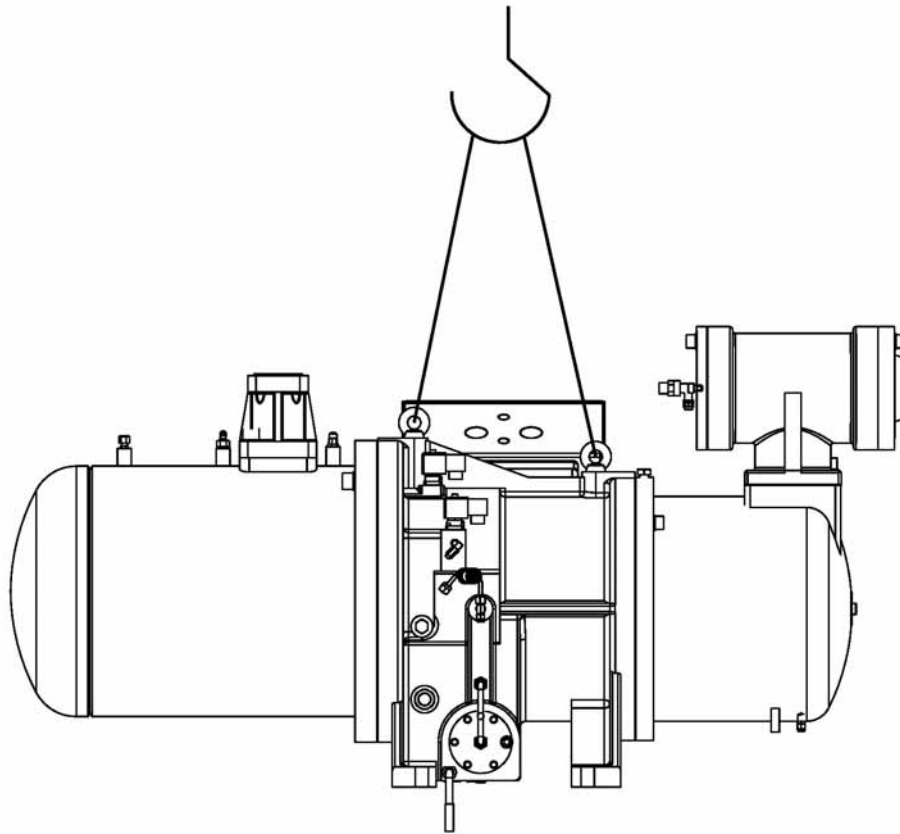

壓縮機運送 Delivery of the compressor

2.1.2 放置

請安裝合適材質之防震腳墊 (5~10mm)於壓縮機腳座上，以阻絕壓縮機振動與噪音之傳遞。避免放置于通風不良、高濕、高溫的地方，並預留日後保養與維修之服務空間。

2.1.2 Installation

Install suitable anti-vibration pads (5-10mm) under the compressor seat to block out the vibration and noise generated by the compressor. Keep compressor from poor-ventilated, high humidity and high temperature environment and reserve plenty of space for maintenance and service in future.

維修空間預留尺寸

Required maintenance space

Unit: cm

位置 Position	型號 Model	SR-1(H)	SR-2(H)	SR-3(H)	SR-434(H)	SR-4(H)	SR-5(H)	SR-561(H)	SR-6(H)	SR-7(H)	SR-8(H)
	SRA-1	SRA-2	SRA-3	SRA-434	SRA-4	SRA-5	SRA-561	SRA-6	SRA-7	SRA-8	
	SF(A)-50	SF(A)-60	SF(A)-70	SF(A)-90	SF(A)-120	SF(A)-140	SF(A)-160	SF(A)-180	SF(A)-230	SF(A)-270	
A	15	15	15	12	-	-	-	-	-	20	
B	27	27	27	27	27	27	27	27	27	27	
C	30	30	30	35	35	35	35	40	40	45	
D	30	30	30	30	35	35	35	40	40	45	
E	15	15	15	15	15	15	15	15	15	15	
F	10	10	10	10	10	10	10	10	10	10	

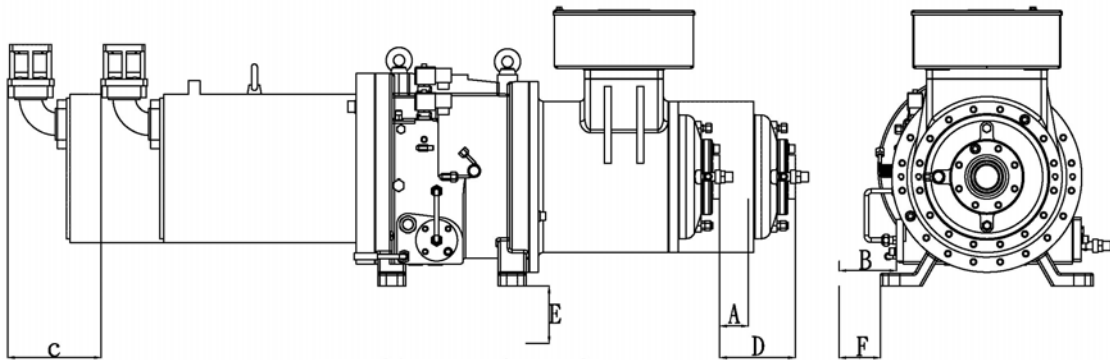

SR(A)-1~3(H)
SF(A)-50~70

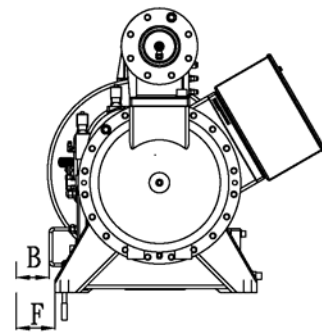
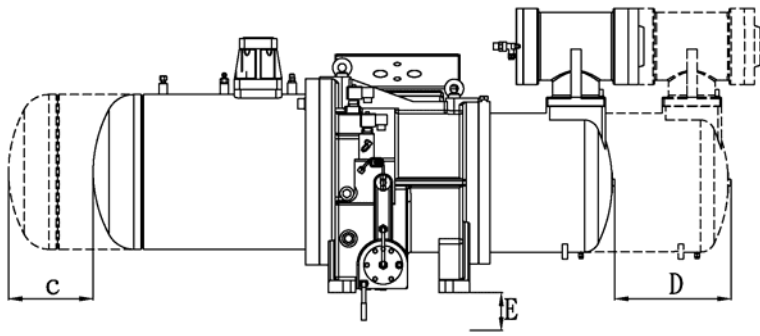

SR(A)-4~79H
SF(A)-120~230

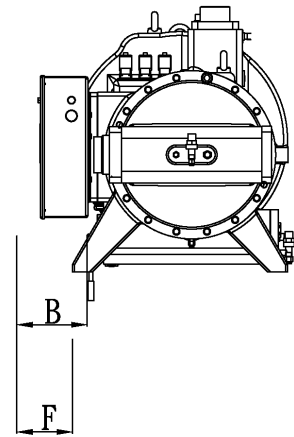
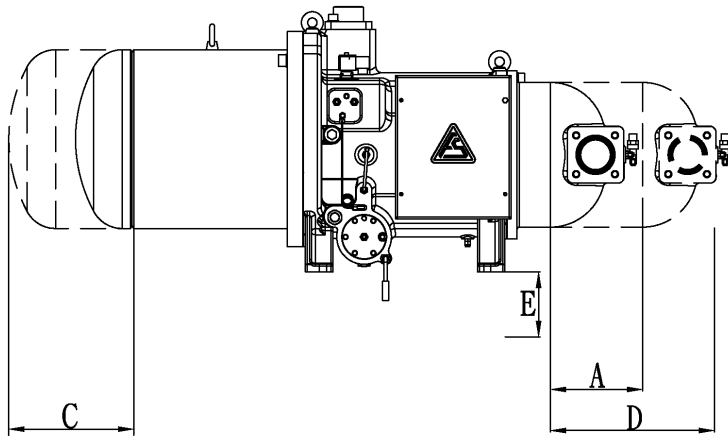

SR(A)-434(H)
SF(A)-90

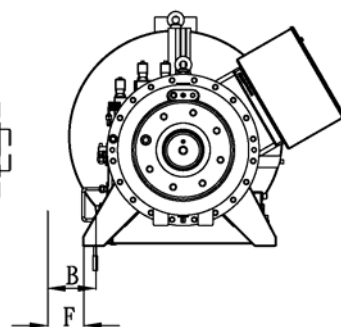
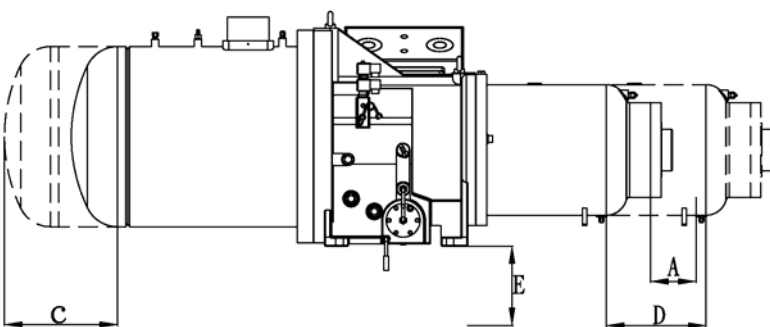

SR(A)-8(H)
SF(A)-270

2.1.3 開封洩壓

安裝相關之零附件時，請先行利用吸入端止回接頭將壓縮機內部充填之氮氣(0.5 bar)排出後，再進行下一步之安裝動作。而出廠之壓縮機已添加所須之冷凍油，由於冷凍油具有強烈之吸濕性，故壓縮機於開封後、配管安裝前，請勿使油品直接暴露在大氣中超過 15 分鐘。

2.1.4 更換油品

若需使用不同之油品，請將壓縮機內部所有潤滑油清理乾淨再添入新油，切記不可二種不同品牌之油混合使用。若須使用特殊油品，請與復盛經銷商連繫。更換新油品後，請啟動油加熱器加熱抽真空。復盛壓縮機可依用戶端應用系統之不同需求，提供不同廠牌之冷凍油，其合成油部份，因其具有強烈的吸濕性，故開封後請勿使油品直接暴露在大氣中。

2.1.5 安裝與配管

管路焊接部位，至少須承受 30 bar 以上之壓力，並於焊接後確實清理焊渣，以避免異物吸入壓縮機內，造成壓縮機損壞。

2.1.6 系統雜質與水份含量限制

冷媒系統中各種雜質的含量直接與壓縮機的效率與運轉壽命有關，是故降低系統內不凝結氣體含量是十分重要的。水份在冷媒系統中易造成凍結阻寒、生銹、破壞馬達線圈絕緣及鍍銅等現象。冷媒管路過長時必須考慮相關設備以達到相同的抽真空效率；冷媒管路中的乾燥劑必要時，務須適時更換，以減少冷媒管路中水份的含量；雜質容許量，以壓縮機吸入口過濾網之壓降為基準，前後壓差不得大於 30 kpa (約 4.3 psi)。當壓差過大，則表示過濾器有過多異物，須拆下濾清器清洗。機組完成試車後，可量測進氣過濾網前後端之壓降，以確認熱交換器銅管及冷媒管路上

2.1.3 Release the sealed Nitrogen

Before installing parts, use the check adaptor at the suction end to release the Nitrogen charged inside the compressor (0.5 bar) first. The new compressor has been filled with lubricant in factory before delivery. Since the lubricant is very hygroscopic, do not expose the lubricant to the atmosphere over 15 minutes after the compressor is unsealed or before installation.

2.1.4 Use of other oil

To use different brand of oil, please empty and clean the internal of compressor completely before adding new oil. Do not mix different brands of oil. Contact Fu Sheng service representative before using any special oil. After oil change, turn on oil heater to heat and vacuum. Since synthetic oil is very hygroscopic; do not expose the oil to the atmosphere over 15 minutes after the compressor is unsealed.

2.1.5 Piping

The welded parts of pipes must withstand over 30-bar of pressure. Be sure to remove all the slag after welding to avoid any foreign objects from being sucked into compressor and causing damages.

2.1.6 Impurity limitation in system

The contaminants in the refrigerant system affect the lifetime and efficiency of compressor directly. It is crucial to reduce non-condensed gas content in the refrigerant system. Moisture mixed with refrigerant tends to block the pipe line due to the frozen water, causes rust to components and damages the winding insulation or generate copper coating on the rotors. If the refrigerant pipeline is very long, it is essential to vacuum the system by connecting pipes to vacuum machine from different part of the chiller unit in order to reach the required vacuum level. It is also important to change the dryer-filter regularly to reduce or eliminate the moisture concentration within the pipeline. The Contaminates can block the suction filter and cause pressure drop over the filter. When the ΔP of suction filter is greater than 30 kpa (4.3 psi) it means the filter is clogged by foreign particle and needs to be cleaned right away. Right after the compressor is installed



相關零組件之清潔度。

2.2 運轉前注意事項

2.2.1 壓縮機

- ◆ 冷凍油油位是否填滿觀油鏡？
- ◆ 機油加熱器加熱時間是否足夠？(長時間停機後，需加熱 8 小時以上)
- ◆ 每一手動閥(冷卻水、冰水之出入口閥及冷媒側之進出口關斷閥)是否皆已開啓？
- ◆ 容調毛細管是否扭曲破損？
- ◆ 馬達線圈與排氣溫度保護開關之接線確實連接且並無作動？

2.2.2 電氣系統

- ◆ 壓縮機之主電源與控制電源之電壓與頻率是否正確？
- ◆ 馬達端子相間與對地之絕緣值是否 $10M\Omega$ 以上？
- ◆ 馬達端子與接地線是否固定確實？
- ◆ 各項控制器之設定值是否正確？

注意：

- ◆ 開始抽真空後直到冷媒充填完成之前，切勿量測絕緣。
- ◆ 新機冷媒充填完成後絕緣量測至少有 $500M\Omega$ (DC500V) 以上，否則應確認是否有抽真空程序不良、冷媒含水量過高、洩漏等因素，並進行矯正。
- ◆ 馬達溫度保護接點請以 DC9V 量測絕緣，切勿使用高阻計。

and commissioned, it is recommended to measure the ΔP of suction filter to ensure the cleanness of copper tubes in heat exchanger and other parts in refrigerant pipeline.

2.2 Items to be checked before startup

2.2.1 Compressor

- ◆ If the oil is filled up to the top level of oil indicator?
- ◆ If the oil heater is turned on before startup? It is recommended to heat up oil for 8 hours if the compressor has been shut down for a long time.
- ◆ If all manual valves (service valves) for the inlet/outlet cooling water, chilling water and refrigerant pipe) have been opened?
- ◆ If the capillary tube is distorted or broken. No damage to the capillary tube is allowed?
- ◆ If the power cables of motor and discharge temperature switch have been connected firmly?

2.2.2 Electrical system

- ◆ If the voltages and frequencies of main and control power sources are correct?
- ◆ If the insulation resistances of phase to phase and phase to ground are higher than $10M\Omega$?
- ◆ If the motor has been grounded and the motor terminals have been fixed tightly?
- ◆ If the controller settings are correct?

Warning:

- ◆ Do not measure the insulation during the vacuum process and before the completion of refrigerant fill-up.
- ◆ After the refrigerant fill-up is accomplished, the measured insulation shall be higher than $500M\Omega$ (measured by DC500V); Otherwise it needs to verify if the system has been vacuumed to the required level, if moisture concentration is too high in refrigerant or if piping is leaking and then take corrective action to solve the problem.
- ◆ Use DC9V ohm meter to measure the insulation of motor protection device (PTC thermistor). Do not measure it by a mega ohmmeter.

2.2.3 管路系統

- ◆ 吸排氣端之配件與管路焊接處是否有洩漏？

2.2.4 抽真空注意事項

- ◆ 儘可能使用大口徑接管抽真空。
- ◆ 高低壓兩側同時抽真空。
- ◆ 冬天或低溫地區抽真空時，儘可能提高週邊溫度以確保效果。
- ◆ 抽真空期間，絕對不得測量馬達絕緣，可能造成馬達線圈嚴重損壞。

2.3 運轉中注意事項

- ◆ 啓動後確認轉向，注意吸氣壓力爲下降、排氣壓力爲上升，否則應立即關機，且變換馬達相序後再開機。
- ◆ 運轉中若有異常之振動及噪音出現，請立即停機，並與復盛維修單位聯繫。
- ◆ 壓縮機運轉過熱度最佳範圍在 R-22/R-134a：5~10°C，R-407C：8~12°C，過熱太大或太小皆有不良影響。系統初啓動時可能因負載大而過熱太大，造成壓縮機馬達線圈溫度保護開關作動而停機。
- ◆ 過熱度不足，可能造成轉子液壓縮而損壞壓縮機。並且造成失油狀況，影響潤滑軸承之功能。
- ◆ 在濕度較高地區，壓縮機應用於低溫系統時，電氣接頭如有水份凝結而影響電氣安全時，請於端子接頭加附絕緣絕熱樹脂，以避免因環境露水造成相間電氣短路。
- ◆ 在低環境溫度下運轉，爲確保最低壓力差在 5 bar 以上，建議採取下列方式因應：
 - 用壓力開關控制冷凝器散熱風扇之

2.2.3 Piping system

- ◆ If there is any leakage from welded piping or accessories connected to pipelines of suction /discharge ends?

2.2.4 Notice in vacuuming process

- ◆ Use the largest connecting pipe available to vacuum the system.
- ◆ Vacuum system on both suction and discharge ends.
- ◆ Try to elevate the surrounding temperature while vacuuming the system in winter or cold environment.
- ◆ Do not measure motor insulation during the vacuuming process. It might severely damage the motor winding.

2.3 Notice in operation

- ◆ Confirm the rotation direction right after the startup. Make sure that the suction pressure shall drop down and discharge pressure shall rise up gradually. Otherwise shut down the compressor immediately, change the phase sequence and then turn on compressor again.
- ◆ If any abnormal vibration or noise is detected during the operation, shut down the compressor immediately and contact Fu Sheng service representative.
- ◆ The recommended superheat range of compressor is 5~10°C (R-22/R-134a), 8~12°C (R-407C). Any superheat beyond the range could cause damage to compressor. The overheat might become too high while compressor starts under heavy initial loading. And the high superheat could cause the motor protection device to trip the compressor.
- ◆ Insufficient superheat could cause liquid compression and result in the damage of compressor. It also causes low oil level in compressor, which leads to insufficient lubrication to bearings.
- ◆ While the compressor is running in refrigeration system or located in a high-humidity region, it is quite possible to find condensed water on the motor terminals that might cause electric shock to individual. Applying insulation resin to the motor terminals can isolate the condensed water and eliminate possible short-circuit.
- ◆ In low-temperature environment, the following actions are recommended to maintain the minimum pressure deviation above 5 bar.
 - Use pressure switch to control the on/off of condenser cooling fan.

啓動與停止。

- 在壓縮機及冷能器之間，加裝壓力維持閥。

2.4 機組出廠運轉注意事項

建議機組廠商于廠內試車前，於壓縮機吸入口前加裝過濾器，試車測試 2~4 小時後，再將其過濾器、進氣過濾器與機油過濾器拆下清洗，清除管路與蒸發器中之焊渣與異物，以避免吸入端壓降過大而破壞濾清器，造成馬達燒毀、轉子、軸承損壞、或滑塊作動不良等現象。

2.5 壓縮機起動/停機控制建議

- ◆ 空重車設定溫度建議以冰水或熱水回水溫度為基準，運轉較穩定。
- ◆ 假設壓縮機控制在冰水回水溫度 11°C 以上 100% 負載運轉、11~10°C 75% 負載運轉、10~9°C 50% 負載運轉、8°C 停機；當冰水回水溫度升高，若設定於 9°C 壓縮機再次啓動運轉，將造成馬達啓動頻繁、起動/停機間距短、馬達積熱無法完全排除、潤滑循環不充分等惡劣狀況。因此強烈建議設定壓縮機於 12°C 以上再次啓動運轉，以避免上述狀況發生。
- ◆ 壓縮機每次到達設定溫度停機前務必以 25% 負載運轉 20~30 秒，確保下次啓動時滑塊在最低負載位置。

- Add a pressure-maintaining valve between the compressor and condenser.

2.4 Notice during factory test

It is recommended to install an extra filter on the suction end of compressor for factory test purpose. Remove and clean this filter, suction filter and oil strainer after the compressor has run for 2 ~ 4 hours. Clean up the pipeline and evaporator. If welding slag or other particles exist in system, they might be carried back to block the suction filter. Eventually, the suction filter could be broken due to high pressure-drop and then the foreign particles can enter compressor freely to damage the motor, bearings, or slide block etc.

2.5 Recommended control sequence of compressor loading/unloading

- ◆ It is recommended to use returned chilling water or hot water temperature as the basis of controlling loading/unloading in order to maintain stable operation.
- ◆ Assume control setting of compressor is based on returned chilling water temperature. If the temperature is above 11°C, compressor runs at 100% loading, if 11~10°C, at 75% loading, if 10~9°C at 50% loading and if below 8°C, compressor shuts down. If compressor re-startup temperature is set at 9°C, it will make motor start frequently. Due to the short re-start cycle, the accumulated heat in motor winding cannot be removed completely by cooling system; the lubrication circulation is insufficient either. To avoid this situation happened, set re-startup temperature at 12°C or above is a must.
- ◆ Before each shutdown, run the compressor at 25% loading for 20 ~ 30 seconds in order to ensure that the slide block is brought back to its initial position for next unloading startup.

3.運轉規範

3.1 運轉範圍

- ◆ 容許操作環境：-10~55℃
- ◆ 容許操作壓力(表壓)：
最高吸氣壓力 R-22(R-407C): 6bar；
R-134a: 3bar.
最高排氣壓力 R-22(R-407C): 25bar；
R-134a: 19bar.
- ◆ 容許最高排氣溫度：110℃

3.2 運轉限制

- ◆ 開機、停機頻率：停機後須待 10 分鐘後，才可再行開機。
- ◆ 每小時馬達之啓動次數不得超過六次。
- ◆ 每次開機運轉時間至少五分鐘以上。
- ◆ 壓縮機停止運轉前，需啓動 25%洩載電磁閥，並維持洩載運轉 20~30 秒，以確保再次啓動時，壓縮機在最低負載狀況下啓動。壓縮機停止運轉後，須將機油加熱器保持通電持續加熱冷凍油，以待壓縮機的再次運轉。

3.3 運轉電源

- ◆ 容許電壓範圍：額定電壓±10%
- ◆ 容許頻率範圍：額定頻率±2%
- ◆ 容許三相電壓不平衡量：±2.25%
- ◆ 容許三相電流不平衡量：±5%

3.OPERATION SPECIFICATION

3.1 Operation range

- ◆ Allowable ambient temperature：-10~55℃
- ◆ Allowable operating pressure (gauge)：
The maximum suction pressure for R-22, R-407C: 6 bar；R-134a: 3 bar.
The maximum discharge pressure for R-22, R47C: 25bar; R-134a: 19 bar.
- ◆ The maximum allowable discharge temperature: 110℃

3.2 Operation limitation

- ◆ The start/stop cycle: restart the compressor at least 10 minutes after it is shut down.
- ◆ The motor start/stop frequency should not exceed six times per hour.
- ◆ The minimum operating time after each startup shall be no less than five minutes.
- ◆ Before shutting down compressor, energize the solenoid valve for 25% loading to unload the capacity for 20-30 seconds to move the slide block back to its initial position for the next startup. This guarantees that compressor can be re-started in the minimum loading state. After compressor is shut down, energize the oil-heater to keep on heating the refrigeration oil and make compressor under standby condition for next startup.

3.3 Power supply

- ◆ Voltage variation: ±10% of rated voltage
- ◆ Frequency variation: ±2% of rated frequency
- ◆ Voltage unbalance between phases: ±2.25%
- ◆ Current unbalance between phases: ±5%

3.4 運轉安全裝置

3.4 Safety device in operation

項次 item	安全裝置 Safety device	建議設定值 Recommended setting
1	高、低壓開關 High/low pressure switch	壓縮機最高運轉壓力不得高於 25bar The maximum discharge pressure shall not exceed 25bar.
2	馬達線圈保護(搭配 PTC 溫度保護控制模組) Motor winding protection (connected to PTC temperature control module)	跳脫溫度：130±5℃；復歸溫度：110±5℃。 Trip temperature: 130±5℃; reset temperature: 110±5℃.
3	排氣高溫保護(搭配 PTC 溫度控制模組) High discharge-temperature protection (connected to PTC temperature control module)	跳脫溫度：110±5℃；復歸溫度 90±5℃ Trip temperature: 110±5℃; reset temperature: 90±5℃.
4	三相過電流保護電驛 Three-phase over-current protection relay	運轉電流可由性能曲線表查得機組允許操作狀態下的最大電流決定。設計機組運轉範圍請參考壓縮機允許運轉範圍。 The setting value can be determined from the maximum current indicated in the performance curve under allowable operation range. Refer to performance data manual.
5	逆相保護器 Phase Inverse protector	
6	欠相保護器 Phase Loss protector	
7	限電壓保護器 Voltage variation protector	
8	油位開關 Oil level switch	連續 15~30sec 呈現低油位時，強制壓縮機停機檢查低油位之原因。 Time-relay setting: 15 ~ 30seconds. If low-oil-level continuously exists for 15-30 sec, compressor shall be compulsorily shutted down. Check the reason for such problem.
9	油壓差保護開關 Oil pressure differential protection switch	壓差設定 1~1.5 bar Pressure difference setting: 1~1.5 bar.
10	最低運轉高低壓差 Minimum pressure diff. in operation	5 bar

註：
建議使用以上基本安全裝置，以確保系統對壓縮機的運轉保護。

Note:
The above safety devices are the minimum requirements applied to protect compressor in operation.

4. 電氣規範

4. ELECTRIC SPECIFICATION

4.1 電氣結線方式

4.1 Electric wiring configuration

接線端子示意圖 Terminal plate illustrated diagram

◆直接啓動 Direct on line

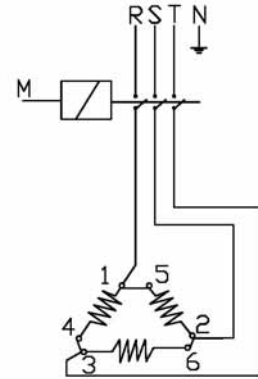
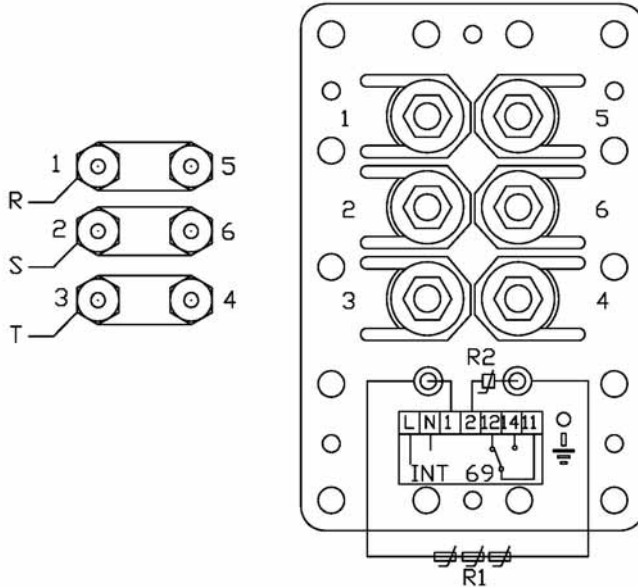

◆Y-△啓動 Star delta

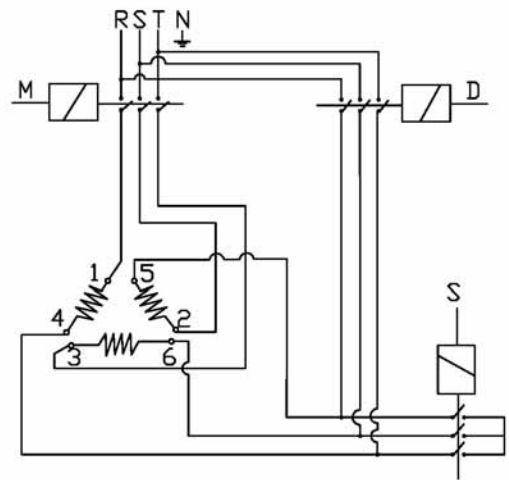
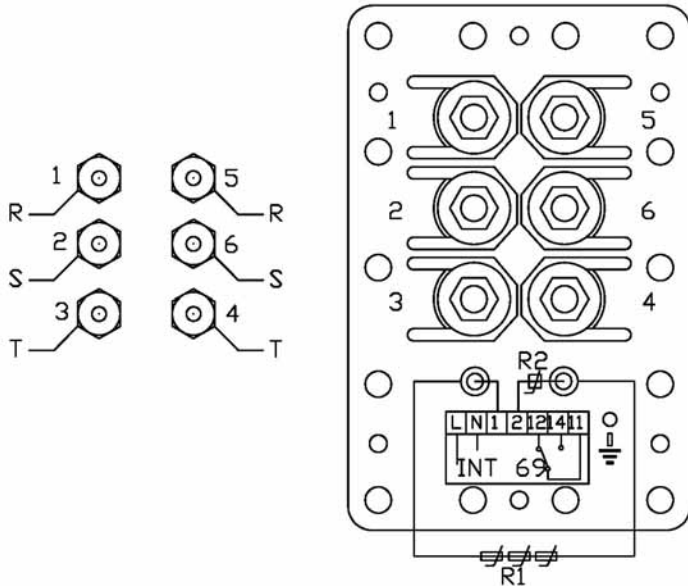

◆注意 Caution:

導柱銅螺帽最大容許鎖緊扭力 The maximum allowed torque of terminal nuts are:
M12 : 50N-M ; M14 : 60N-M

◆符號說明 Legend:

R1: Motor thermistor PTC
R2: Discharge Temp. thermistor PTC
R-S-T: Power supply
M, S: Start contactors
M, D: Run contactors

L/N: Phase/neutral 230V(115V) - 50Hz/ 60Hz
11/14: Control circuit(NO)
11/12: Control circuit(NC)
1/2 : Conn. wires to thermistor(INT69)

建議配電線徑值表

Recommended wire diameter table

導線截面積 Wire cross-section area (mm ²)	14	22	30	38	50	60	80	100	125	150	200	250	325	400	500
允許電流量 Allowable current (A)	55	70	90	100	120	140	165	190	220	250	300	355	415	475	535

註:以上導線數不包括中性線、接地線、控制線及訊號線等線路

Note: The conductors do not include the neutral line, grounding line or signal line.

4.2 啓動程序

Y-Δ轉換時之電磁接觸器切換時間須控制在 40msec 以下，設定切換值時須注意電磁接觸器消弧能力。完成整個起動程序後，壓縮機載入須注意回水溫度。若季節變換，系統負載小，壓縮機直接加載至 100%易造成壓縮機起動次數頻繁而降低壓縮機壽命(參照 2.5 壓縮機加載/洩載控制建議)。

4.2 Start-up sequence

While converting Y-Δ, the magnetic contactor switchover time should be set within 40 ms. It is necessary to consider the electrical-arc eliminating capability when setting up the switchover time. After completing the entire start-up process, keep an eye on the returned chilling water temperature. Low returned chilling water temperature means the system loading is lower than designed capacity. Under this circumstance, it would cause frequent startup and shorten compressor's operation lifetime if the compressor is running at full loading (100%) right after the startup. (Refer to Sec. 2.5: Recommended control sequence of compressor loading/unloading).

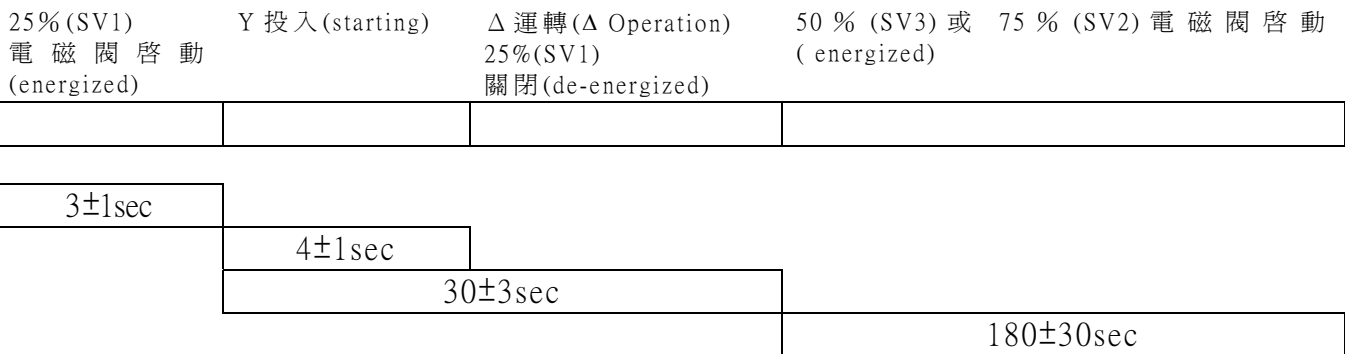

4.3 進相電容使用注意事項

- ◆ 壓縮機起動完成後至少 0.5 秒，再連接進相電容。
- ◆ 功因補償上限為 0.95。
- ◆ 停機前一秒(至少)，先切離進相電容。
- ◆ 原則上進相電容僅在運轉中作用。

4.3 Notice on using phase-leading capacitor

- ◆ Connect phase-leading capacitor at least 0.5 sec after compressor start-up.
- ◆ The upper limit of power factor compensation is 0.95.
- ◆ Cut off the phase-leading capacitor at least one second before shutting down compressor.
- ◆ Basically the phase-leading capacitor is activated only while compressor is in operation.



4.4 無熔絲開關(NFB)之選用

無熔絲開關的選用主要考慮框架容量 AF(KVA)、額定跳脫電流 AT、額定電壓(V)三項電氣特性，低電壓配線器具建議選用標準，可將選用容量估算方式為：框架容量 AF 取大於起斷電流 AT 一等級之值。

$$\text{額定跳脫電流 AT(A)} = \text{起動電流乘率 (1.5~2.5)} \times \text{電動機額定電流}$$

此外，當同一冰水機組有多台壓縮機時不允許同時啟動壓縮機，而不同時序啟動之額定跳脫電流 AT 估算，建議低電壓配線器具選用標準，可將選用容量估算方式：

$$\text{額定跳脫電流 AT(A)} = \text{起動電流乘率} \times \text{最大電動機額定電流} + \text{其餘電動機額定電流總和}$$

4.5 電磁接觸器 MC 之選用

電磁接觸器的選用除考慮使用電壓、控制電壓外，最重要的是考慮連續電流 I_{th} 之大小(亦即接點承受之電流大小)，連續電流 I_{th} 的估算方式建議為 $I_{th} = \text{馬達額定電流} \times 1.25 / \sqrt{3}$ 。

4.4 NFB selection

Selection of NFB is based on the Frame capacity AF and Interrupting Current AT (A). After the AT is decided, choose the next larger grade frame capacity AF.

$$\text{AT(A)} = \text{start-up current factor (1.5-2.5)} \times \text{motor rated current}$$

Besides, it is not allowed to start two or more compressors concurrently in a multi-compressor chiller. To select the AT under different starting sequence, follow the formula:

$$\text{AT(A)} = \text{start-up current factor} \times \text{rated current of the largest motor} + \text{sum of all other motors' rated currents}$$

4.5 Magnetic contactor (MC) selection

Except the operation voltage and control voltage, the most important factor in MC selection is the scale of I_{th} (current flowing through the contacting point). The formula is: $I_{th} = \text{motor's rated current} \times 1.25 / \sqrt{3}$.

4.6 電氣資料 Electrical data

■ 50Hz

SR, SF series:

機種 Model		SR-1	SR-2	SR-3	SR-434/II	SR-4	SR-5/561	SR-6	SR-7	SR-8	
		SF-50	SF-60	SF-70	SF-90	SF-120	SF-140/160	SF-180	SF-230	SF-270	
公稱馬力 Nominal HP		50	60	70	96	125	145	200	225	267	
功率 Power (kW)		37	45	52	72	93	108	149	168	199	
50Hz 380V	Y 接線堵住電流 Star -LRA (A)	124	137	188	224	276	345	519	634	692	
	Δ 接線堵住電流 Delta -LRA (A)	404	438	607	717	861	1070	1635	1980	2247	
	額定電流 RLA(A)	69	85	96	129	171	203	272	306	352	
	導線選用 Wire selected	需求安培容量 Maximum capacity(A)		48	59	68	93	123	143	195	218
		參考線徑 Nominal cross section(mm)		14	22	30	38	50	60	80	100
		NFB AF		100	225	225	225	400	400	600	600
		NFB AT (A)		100	125	150	200	300	300	500	500
		M・D 接觸器電流 Magnetic contact current(A)		50	65	80	90	125	150	200	220
	S 接觸器電流 Magnetic contact current(A)		35	35	50	50	80	80	125	150	

SR-H series:

機種 Model		SR-1H	SR-2H	SR-3H	SR-434H	SR-4H	SR-5/ 561H	SR-6H	SR-7H	SR-8H	
		公稱馬力 Nominal HP		60	70	90	108	145	175	225	267
功率 Power (kW)		45	52	67	81	108	131	168	199	221	
50Hz 380V	Y 接線堵住電流 Star -LRA (A)	137	188	257	279	345	445	634	692	850	
	Δ 接線堵住電流 Delta -LRA (A)	438	607	802	888	1070	1434	1980	2247	2647	
	額定電流 RLA(A)	85	96	124	147	203	241	306	352	397	
	導線選用 Wire selected	需求安培容量 Maximum capacity(A)		59	68	93	123	143	195	218	256
		參考線徑 Nominal cross section(mm)		22	30	38	50	60	80	100	125
		NFB AF		225	225	225	400	400	600	600	600
		NFB AT (A)		125	150	200	300	300	500	500	600
		M・D 接觸器電流 Magnetic contact current(A)		65	80	100	125	150	220	300	300
	S 接觸器電流 Magnetic contact current(A)		35	50	50	80	80	125	150	150	

SRA, SFA series :

機種 Model		SRA-1	SRA-2	SRA-3	SRA-434	SRA-4	SRA-5/561	SRA-6	SRA-7	SRA-8	
		SFA-50	SFA-60	SFA-70	SFA-90	SFA-120	SFA-140/160	SFA-180	SFA-230	SFA-270	
公稱馬力 Nominal HP		42	50	60	75	96	108	145	175	225	
功率 Power (kW)		32	37	45	56	72	81	108	131	168	
50Hz 380V	Y 接線堵住電流 Star -LRA (A)	113	124	137	177	224	279	345	445	634	
	Δ 接線堵住電流 Delta -LRA (A)	367	404	438	563	717	888	1070	1434	1980	
	額定電流 RLA(A)	57	69	85	102	129	147	203	241	306	
	導線選用 Wire selected	需求安培容量 Maximum capacity(A)		40	48	59	72	93	105	143	166
		參考線徑 Nominal cross section(mm)		8	14	22	30	38	50	80	100
		NFB AF		90	100	125	150	200	225	300	350
		NFB AT (A)		80	100	120	150	190	220	300	350
		M・D 接觸器電流 Magnetic contact current(A)		50	50	65	80	100	125	150	180
	S 接觸器電流 Magnetic contact current(A)		20	35	35	50	50	65	80	100	

■ 60Hz

SR series:

機種 Model		SR-1	SR-2	SR-3	SR-434I/II	SR-4	SR-5/561	SR-6	SR-7	SR-8	
		SF-50	SF-60	SF-70	SF-90	SF-120	SF-140/160	SF-180	SF-230	SF-270	
公稱馬力 Nominal HP		60	72	84	115	150	175	240	270	320	
功率 Power (kW)		45	54	63	86	112	131	179	201	239	
60Hz 220V	Y 接線堵住電流 Star -LRA (A)	292	310	417	471	582	732	-	1427	-	
	Δ 接線堵住電流 Delta -LRA (A)	930	990	1342	1460	1850	2271	-	4458	-	
	額定電流 RLA(A)	142	169	198	268	354	412	-	630	-	
	導線選用 Wire selected	需求安培容量 Maximum capacity(A)									
		參考線徑 Nominal cross section(mm)									
		50	60	80	125	200	200	-	-	-	-
		NFB AF									
		225	250	400	400	600	800	-	-	-	-
	NFB AT (A)										
	220	250	300	400	600	700	-	-	-	-	
	M、D 接觸器電流 Magnetic contact current(A)										
	100	125	150	200	300	300	-	-	-	-	
	S 接觸器電流 Magnetic contact current(A)										
	65	80	80	125	150	180	-	-	-	-	
60Hz 380V	Y 接線堵住電流 Star -LRA (A)	167	182	245	265	334	436	678	796	911	
	Δ 接線堵住電流 Delta -LRA (A)	533	582	789	840	1062	1352	2072	2487	2968	
	額定電流 RLA(A)	82	98	115	155	201	241	322	359	431	
	導線選用 Wire selected	需求安培容量 Maximum capacity(A)									
		參考線徑 Nominal cross section(mm)									
		22	30	30	50	80	100	150	200	250	250
		NFB AF									
		225	225	225	250	400	400	600	600	800	800
	NFB AT (A)										
	125	150	200	250	300	400	500	600	700	700	
	M、D 接觸器電流 Magnetic contact current(A)										
	65	80	80	125	150	180	300	300	400	400	
	S 接觸器電流 Magnetic contact current(A)										
	35	50	50	65	80	100	150	150	180	180	
60Hz 440V	Y 接線堵住電流 Star -LRA (A)	144	155	215	241	291	366	586	717	793	
	Δ 接線堵住電流 Delta -LRA (A)	460	495	690	747	925	1136	1790	2242	2582	
	額定電流 RLA(A)	71	85	100	134	177	206	278	315	373	
	導線選用 Wire selected	需求安培容量 Maximum capacity(A)									
		參考線徑 Nominal cross section(mm)									
		14	22	30	38	60	80	125	150	200	200
		NFB AF									
		225	225	225	225	400	400	600	600	600	600
	NFB AT (A)										
	125	150	150	200	300	400	500	500	600	600	
	M、D 接觸器電流 Magnetic contact current(A)										
	65	65	80	100	150	150	220	300	300	300	
	S 接觸器電流 Magnetic contact current(A)										
	35	50	50	65	80	100	125	150	180	180	
60Hz 460V	Y 接線堵住電流 Star -LRA (A)	125	138	190	233	293	356	550	672	733	
	Δ 接線堵住電流 Delta -LRA (A)	407	441	611	722	913	1156	1730	2099	2382	
	額定電流 RLA(A)	69	82	94	129	169	201	272	302	349	
	導線選用 Wire selected	需求安培容量 Maximum capacity(A)									
		參考線徑 Nominal cross section(mm)									
		14	22	22	-	60	80	125	125	200	200
		NFB AF									
		100	225	225	-	250	400	400	600	600	600
	NFB AT (A)										
	100	125	150	-	250	300	400	500	600	600	
	M、D 接觸器電流 Magnetic contact current(A)										
	50	65	80	-	125	150	220	220	300	300	
	S 接觸器電流 Magnetic contact current(A)										
	35	35	50	-	80	80	125	125	150	150	

■ 60Hz

SR-H series:

機種 Model		SR-1H	SR-2H	SR-3H	SR-434H	SR-4H	SR-5/561H	SR-6H	SR-7H	SR-8H	
公稱馬力 Nominal HP		72	84	108	130	175	210	270	320	355	
功率 Power (kW)		54	63	81	97	131	157	201	239	265	
60Hz 220V	Y 接線堵住電流 Star -LRA (A)	310	417	539	596	732	982	1427	-	-	
	Δ 接線堵住電流 Delta -LRA (A)	990	1342	1631	1890	2271	3167	4458	-	-	
	額定電流 RLA(A)	169	198	259	302	412	483	630	-	-	
	導線選用 Wire selected	需求安培容量 Maximum capacity(A)	122	143	188	218	297	351	-	-	-
		參考線徑 Nominal cross section(mm)	60	80	100	125	200	250	-	-	-
	NFB AF		250	400	400	600	800	800	-	-	-
	NFB AT (A)		250	300	400	500	700	800	-	-	-
	M、D 接觸器電流 Magnetic contact current(A)		125	150	220	220	300	400	-	-	-
S 接觸器電流 Magnetic contact current(A)		80	80	125	150	180	220	-	-	-	
60Hz 380V	Y 接線堵住電流 Star -LRA (A)	182	245	297	345	436	570	796	911	1192	
	Δ 接線堵住電流 Delta -LRA (A)	582	789	900	1094	1352	1838	2487	2968	3814	
	額定電流 RLA(A)	98	115	148	175	241	280	359	431	474	
	導線選用 Wire selected	需求安培容量 Maximum capacity(A)	71	83	107	126	174	204	259	311	-
		參考線徑 Nominal cross section(mm)	30	30	50	60	100	125	200	250	-
	NFB AF		225	225	225	400	400	600	600	800	-
	NFB AT (A)		150	200	225	300	400	500	600	700	-
	M、D 接觸器電流 Magnetic contact current(A)		80	80	125	150	180	220	300	400	-
S 接觸器電流 Magnetic contact current(A)		50	65	65	80	100	125	150	180	-	
60Hz 440V	Y 接線堵住電流 Star -LRA (A)	155	215	269	302	366	494	717	793	1028	
	Δ 接線堵住電流 Delta -LRA (A)	495	690	817	937	1136	1592	2242	2582	3290	
	額定電流 RLA(A)	85	100	129	150	206	241	315	375	409	
	導線選用 Wire selected	需求安培容量 Maximum capacity(A)	61	72	94	109	149	175	227	269	-
		參考線徑 Nominal cross section(mm)	22	30	38	50	80	100	150	200	-
	NFB AF		225	225	225	250	400	400	600	600	-
	NFB AT (A)		150	150	200	250	350	400	500	600	-
	M、D 接觸器電流 Magnetic contact current(A)		65	80	100	125	150	180	300	300	-
S 接觸器電流 Magnetic contact current(A)		50	50	50	65	100	100	150	180	-	
60Hz 460V	Y 接線堵住電流 Star -LRA (A)	138	190	259	296	356	472	672	733	900	
	Δ 接線堵住電流 Delta -LRA (A)	441	611	808	940	1156	1520	2099	2382	2800	
	額定電流 RLA(A)	82	94	124	145	201	239	302	349	402	
	導線選用 Wire selected	需求安培容量 Maximum capacity(A)	58	68	90	105	143	168	214	253	-
		參考線徑 Nominal cross section(mm)	22	22	30	50	80	100	125	200	-
	NFB AF		225	225	225	225	400	400	600	600	-
	NFB AT (A)		125	150	200	225	300	350	500	600	-
	M、D 接觸器電流 Magnetic contact current(A)		65	80	100	100	150	180	220	300	-
S 接觸器電流 Magnetic contact current(A)		35	50	50	65	80	100	125	150	-	

■ 60Hz

SRA , SFA series:

機種 Model		SRA-1	SRA-2	SRA-3	SRA-434	SRA-4	SRA-5/ 561	SRA-6	SRA-7	SRA-8	
		SFA-50	SFA-60	SFA-70	SFA-90	SFA-120	SFA-140 /160	SFA-180	SFA-230	SFA-270	
公稱馬力 Nominal HP		50	60	72	90	115	130	175	210	270	
功率 Power (kW)		37	45	54	67	86	97	131	157	201	
60Hz 220V	Y 接線堵住電流 Star -LRA (A)	254	292	310	398	471	596	732	982	1427	
	Δ 接線堵住電流 Delta -LRA (A)	814	930	990	1230	1460	1890	2271	3167	4458	
	額定電流 RLA(A)	120	142	169	213	268	302	412	483	630	
	導線 選用 Wire selected	需求安培容量 Maximum capacity(A)	86	104	122	152	193	218	297	351	-
		參考線徑 cross section(mm)	30	50	60	80	125	125	200	250	-
	NFB AF		225	225	250	400	400	600	800	800	-
	NFB AT (A)		200	225	250	350	400	500	700	800	-
	M、D 接觸器電流 Magnetic contact current(A)		100	100	125	150	220	220	300	400	-
S 接觸器電流 Magnetic contact current(A)		50	65	80	100	125	150	180	220	-	
60Hz 380V	Y 接線堵住電流 Star -LRA (A)	141	167	182	231	265	345	436	570	796	
	Δ 接線堵住電流 Delta -LRA (A)	459	533	582	714	840	1094	1352	1838	2487	
	額定電流 RLA(A)	69	82	98	123	155	175	241	280	359	
	導線 選用 Wire selected	需求安培容量 Maximum capacity(A)	49	60	71	88	112	126	174	204	259
		參考線徑 cross section(mm)	14	22	30	30	50	60	100	125	200
	NFB AF		100	225	225	225	250	400	400	600	600
	NFB AT (A)		100	125	150	200	250	300	400	500	600
	M、D 接觸器電流 Magnetic contact current(A)		50	65	80	100	125	150	180	220	300
S 接觸器電流 Magnetic contact current(A)		35	35	50	50	65	80	100	125	150	
60Hz 440V	Y 接線堵住電流 Star -LRA (A)	130	144	155	190	241	302	366	494	717	
	Δ 接線堵住電流 Delta -LRA (A)	403	460	495	589	747	937	1136	1592	2242	
	額定電流 RLA(A)	59	71	85	106	134	150	206	241	315	
	導線 選用 Wire selected	需求安培容量 Maximum capacity(A)	43	52	61	76	97	109	149	175	227
		參考線徑 cross section(mm)	14	14	22	30	38	50	80	100	150
	NFB AF		100	225	225	225	225	250	400	400	600
	NFB AT (A)		100	125	150	200	200	250	350	400	500
	M、D 接觸器電流 Magnetic contact current(A)		50	50	65	80	100	125	150	180	300
S 接觸器電流 Magnetic contact current(A)		35	35	50	50	65	65	100	100	150	
60Hz 460V	Y 接線堵住電流 Star -LRA (A)	114	125	138	178	233	296	356	472	672	
	Δ 接線堵住電流 Delta -LRA (A)	370	407	441	567	722	940	1156	1520	2099	
	額定電流 RLA(A)	57	69	82	100	129	145	201	239	302	
	導線 選用 Wire selected	需求安培容量 Maximum capacity(A)	40	48	58	72	-	105	143	168	214
		參考線徑 cross section(mm)	8	14	22	30	-	50	80	100	125
	NFB AF		100	100	225	225	-	225	400	400	600
	NFB AT (A)		100	100	125	150	-	225	300	350	500
	M、D 接觸器電流 Magnetic contact current(A)		50	50	65	80	-	100	150	180	220
S 接觸器電流 Magnetic contact current(A)		20	35	35	50	-	65	80	100	125	

5. 故障分析與保養週期

5. TROUBLE SHOOTING AND MAINTENANCE PERIOD

5.1 故障分析與研判

5.1 Trouble shooting

故障狀況	原因
壓縮機馬達線圈，保護開關作動 Motor winding temperature-protecting switch is activated	<ol style="list-style-type: none"> 1. 負載大造成低壓側入口過熱度過高。 High compressor superheat due to heavy loading. 2. 高壓過高，負載過大。 Discharge pressure is too high and causes overload. 3. 線圈保護開關故障。 Motor winding temperature-protecting switch is out of order. 4. 電氣系統不良或故障。 Electric system is failed. 5. 馬達線圈不良，溫升過高。 Defective motor winding that causes high temperature rise-up.
容調動作不確實 Modulation (slide) block fails to move properly	<ol style="list-style-type: none"> 1. 溫度過低，潤滑油黏度高。 Low temperature causes high oil viscosity. 2. 毛細管阻塞。 Capillary tube is clogged. 3. 容調電磁閥泄放孔口阻塞。 The solenoid valve orifice is clogged. 4. 容調電磁閥線圈故障。 The solenoid valve coil fails. 5. 容調活塞環磨損無法完全氣密，冷媒大量進入容調油壓缸中。 The piston ring is worn out. 6. 容調油路阻塞。 Oil path is clogged. 7. 油過濾器阻塞。 Oil strainer is clogged. 8. 潤滑油量不足(油位不足)。 Insufficient oil.(low oil level) 9. 系統之溫度開關故障。 System temperature switch fails.
馬達無法啓動或 Y- 無法啓動 Unable to start motor or operate	<ol style="list-style-type: none"> 1. 容調閥無法回復空車狀態，造成重車起動 The slide block cannot return back to no-load state that results in loaded startup. 2. 電壓過低。 Voltage is too low. 3. 電壓錯誤。 Voltage is not correct. 4. 馬達故障。 Motor fails 5. 欠相、逆相運轉。

	<p>Phase loss or phase inverse.</p> <p>6. 馬達保護開關作動。 Motor protection switch is activated.</p> <p>7. 馬達線圈接線錯誤。 Motor is not connected correctly.</p> <p>8. 排氣關斷閥未開(高壓開關作動)。 Discharge service valve is closed (high-pressure switch is activated).</p>
<p>異常振動或噪音 Abnormal vibration or noise</p>	<p>1. 軸承損壞故障。 Bearing fails.</p> <p>2. 機體內部固定螺絲鬆動。 Inner fixed screws are loosened.</p> <p>3. 轉子相互摩擦或與機殼摩擦。 Rotor contacts against the other one or casing.</p> <p>4. 失油。 Oil loss.</p> <p>5. 內部機件鬆動。 Inner parts are loosened.</p> <p>6. 電磁聲。 EM noise.</p> <p>7. 有異物進入。 Foreign particles enter compressor.</p>
<p>排氣溫度過高 High discharge temperature</p>	<p>1. 過熱度過高。 Superheat is too high.</p> <p>2. 高壓過高，負載過大。 Discharge pressure or loading is too high.</p> <p>3. 失油。 Low oil level.</p> <p>4. 軸承損壞。 Bearing fails.</p> <p>5. 電動機過熱。 Motor is overheated.</p> <p>6. 壓縮比過大。 Compression ratio is too high.</p>
<p>壓縮機失油 Oil loss</p>	<p>1. 過熱度不足，液態冷媒回流過多，引起回油不良。 Insufficient superheat and too much liquid refrigerant returning to compressor cause poor oil circulation in system.</p> <p>2. 系統流速設計不足，匹配不合理。 Low designed flow velocity causes poor oil circulation.</p> <p>3. 系統較大或有彎角處儲存積油，致使冷凍油不足，需補充冷凍油。 Piping is too long or oil is accumulated at elbows of piping system, which causes insufficient oil. Need to charge more oil.</p>

5.2 保養週期建議表

5.2 Recommended maintenance period

時間 Time	1000hr	2500hr	5000hr	10000hr	15000hr	20000hr	25000hr	30000hr
項目 Item								
電氣絕緣 Electrical insulation		△	△	△	△	△	△	△
油過濾器 Oil strainer								△
進氣過濾器 Suction filter								△
潤滑油 Lubricant		△		△/○		△/○		△/○
油位 Oil level	△	△	△	△	△	△	△	△
振動噪音 Vibration/noise	△	△	△	△	△	△	△	△
吸排氣端襯墊 Suction/discharge end's pad								△
軸承 Bearing								△/○
接頭部位洩漏 Leakage								△

△檢查 Check；○更換 Replace

注意事項 Note：

- 馬達電氣絕緣除了表中之定期檢查外，每年在新啓動運轉前檢查其絕緣狀況。
After a long period of shutdown, an electrical insulation check should be conducted before new operation.
- 振動、噪音之檢查以人為方式檢查即可，若發現有異常狀況，可聯繫復盛公司。詳細以儀器檢查，以確定原因。
Manually check vibration and noise. If abnormality is found, contact Fu Sheng service department.
- 每次大修後，整台壓縮機須重做一次耐壓試漏，以確定各部位無洩漏。
Conduct a pressure test on compressor after each overhaul to ensure no any leakage is occurred.
- 軸承壓換時須整組同時更換，不可只更換其中部份軸承。
Replace all bearings concurrently instead of part of them.

5.3 壓縮機馬達燒毀之處理

當馬達不慎燒毀時，請將燒毀之壓縮機拆下，回收系統髒冷媒避免污染環境，並更換乾燥過濾器。(而新機尚未裝機之前，請先將系統抽真空、充氮氣封存，以免系統受環境濕氣腐蝕。)更換新機試運轉一小時後，請停機更換新的冷凍油與乾燥過濾器後再運轉一小時，確認系統之清潔度及油寒酸是否合格，若否則反覆上述動作。

5.4 PUMP DOWN 注意事項

- ◆除非有停機檢測或維修之必要，請勿於標準控制中作 PUMP DOWN。
- ◆請注意壓縮機之排氣溫度，如排氣溫度開關作動時，應立即停止 PUMP DOWN 之動作。
- ◆PUMP DOWN 之最低吸氣壓力不得低於 0.5 bar(表壓)。

6.應用

依據復盛壓縮機之許用運轉範圍，如使用于風冷及熱泵機組，其使用之狀態均較水冷機組嚴苛，負載約提高 15%~30%，將造成排氣高溫，馬達線圈溫度過高及油溫太高等現象。為使機組可以正常達到運轉要求，需配置液噴射或油冷卻器，使其得到運轉範圍中之額外冷卻。

6.1 液噴射

引用系統中一部份液態冷媒，直接進入壓縮室或馬達吸氣側藉以降低排氣溫度和馬達線圈溫度，若排氣溫度達到 100°C 時，溫度開關感應排氣溫度而控制液冷媒之電磁閥，而液冷媒通過電磁閥和節流裝置，進入壓縮室或馬達吸氣側，利用液冷媒潛熱，得到冷卻效

5.3 Handling a burnt out motor

If the motor is burnt out, disassemble the compressor, recycle the dirty refrigerant and replace the dryer filter (before the new compressor is installed, vacuum the system and charge with nitrogen first to block it out from ambient moisture). After making test run to the new compressor for one hour, stop it, replace new refrigeration oil & dry-filter and make another one-hour run to confirm whether the system purity and oil are well qualified. If not, repeat the above procedure till acceptable.

5.4 Notice on pump-down

- ◆Do not conduct pump-down during the standard control process unless it is really essential to shutdown for making inspection or maintenance,
- ◆Keep monitoring the discharge temperature. Once the discharge temperature switch is activated, stop pump-down at once.
- ◆The minimum pump-down suction pressure shall be 0.5 bar (gauge).

6. APPLICATION

According to the allowed operation range of Fu-Sheng compressor, the operation condition under air-cooled or heat-pump applications is more critical than water-cooled one; the loading of the former condition is about 15%-30% higher than the later one, which would make discharge temperature, motor winding temperature and oil temperature high. To let compressor run normally, it's essential to install liquid injection system or oil cooler to get additional cooling to the compressor.

6.1 Liquid injection

Inject some liquid refrigerant directly into the compression chamber or compressor suction end to reduce the discharge and motor winding temperature. When the discharge temperature is up to 100°C, the temperature switch sends a signal to the solenoid valve to let the liquid refrigerant enter compression chamber or motor suction end through the solenoid valve and throttling

果。如採用感溫式膨脹閥，需留意膨脹閥控制會有不穩定現象，要依使用狀況加以調整，建議使用液噴專用膨脹閥（如：Danfoss TEAT20，Alco series 935-100，Sprlan Y1037），其配置如下圖。

device. The latent heat of refrigerant provides required cooling capacity to cool down the compressor when running at critical condition. If a thermal expansion valve is not specially designed for the liquid injection application, a solenoid valve is required to control the open/close of the expansion valve and make the system stable. It is recommended to use specific expansion valves (ex. Danfoss TEAT20, Alco series 935 or Sprlan Y1037, etc.) to control the liquid injection. Illustrated piping layout is shown below.

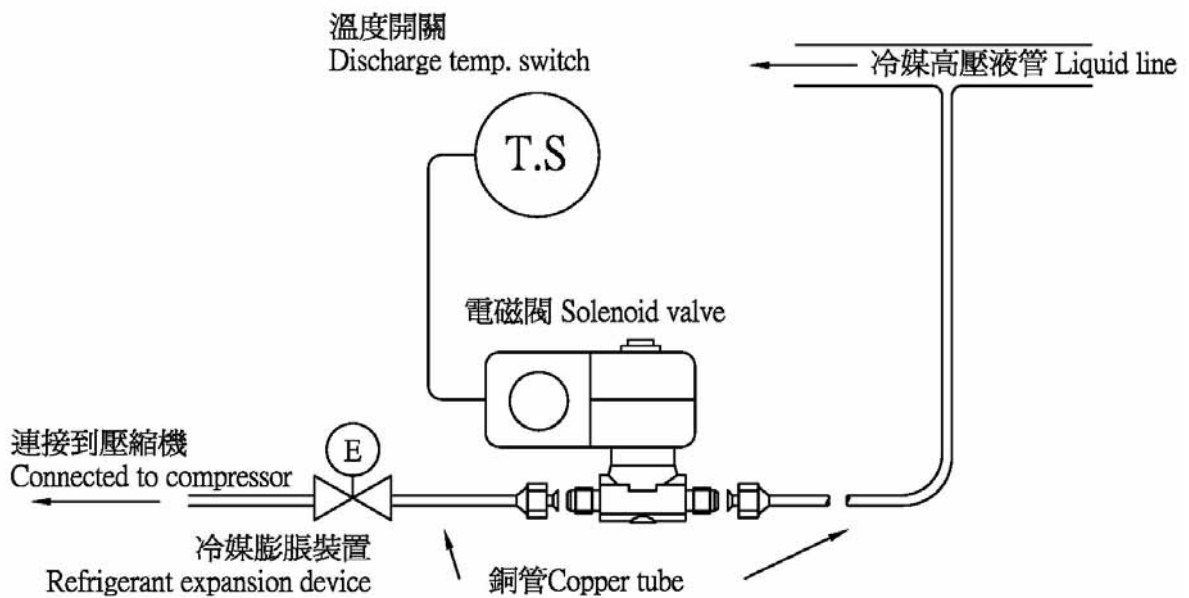

液噴射配置圖 Liquid injection layout

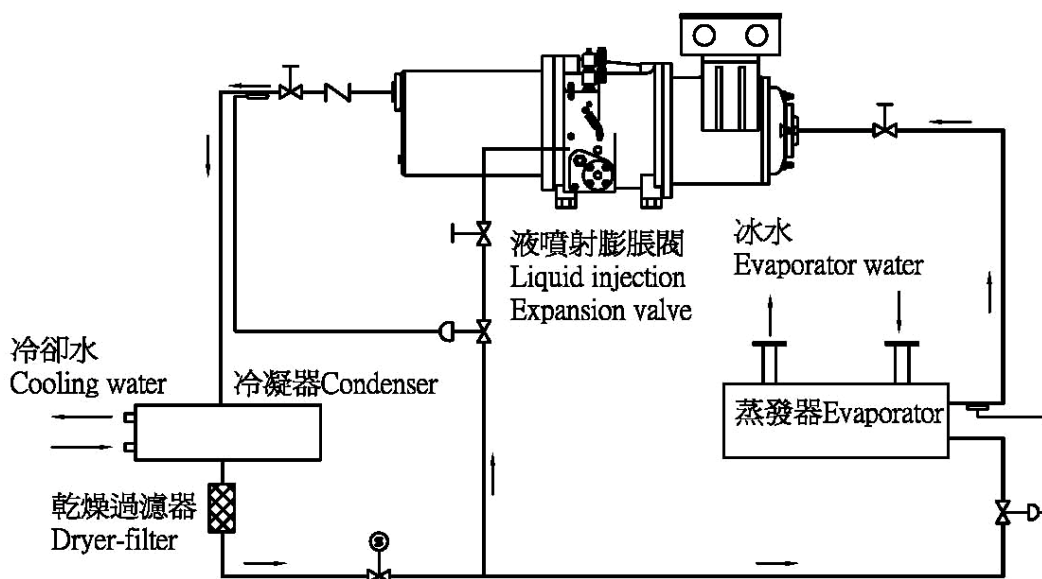
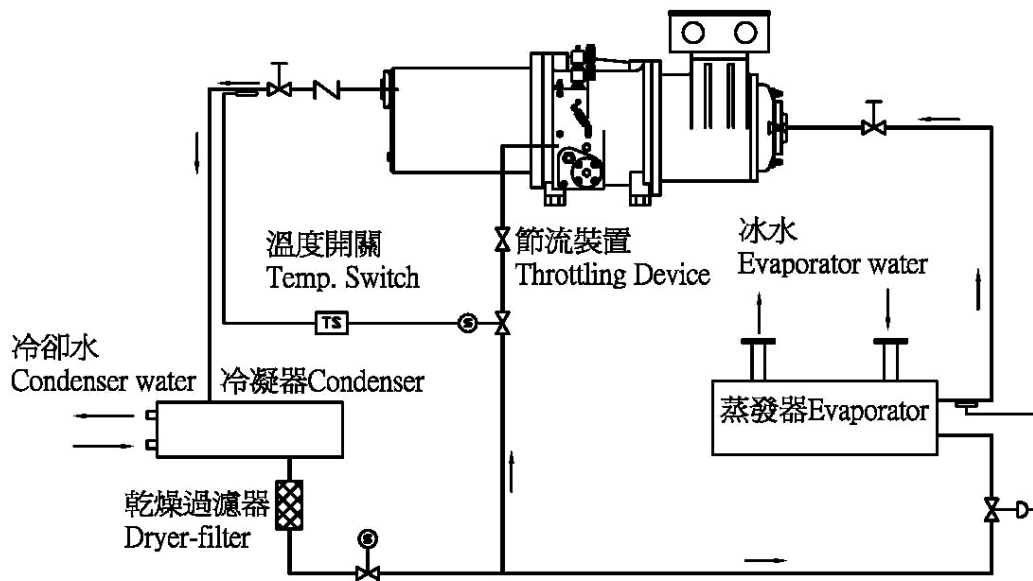

液噴射 Liquid injection
(中間壓) (Middle pressure)

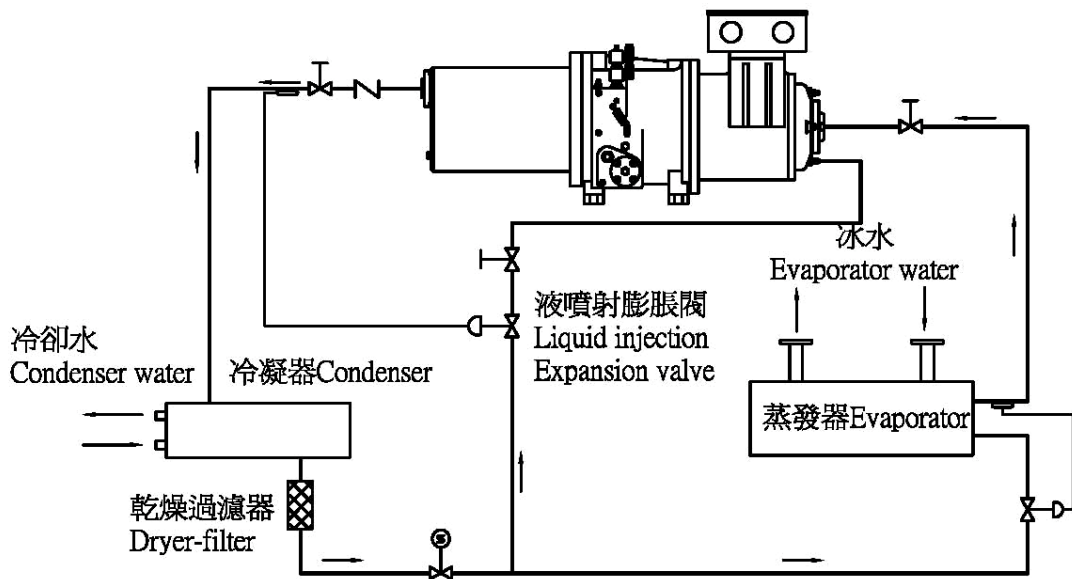
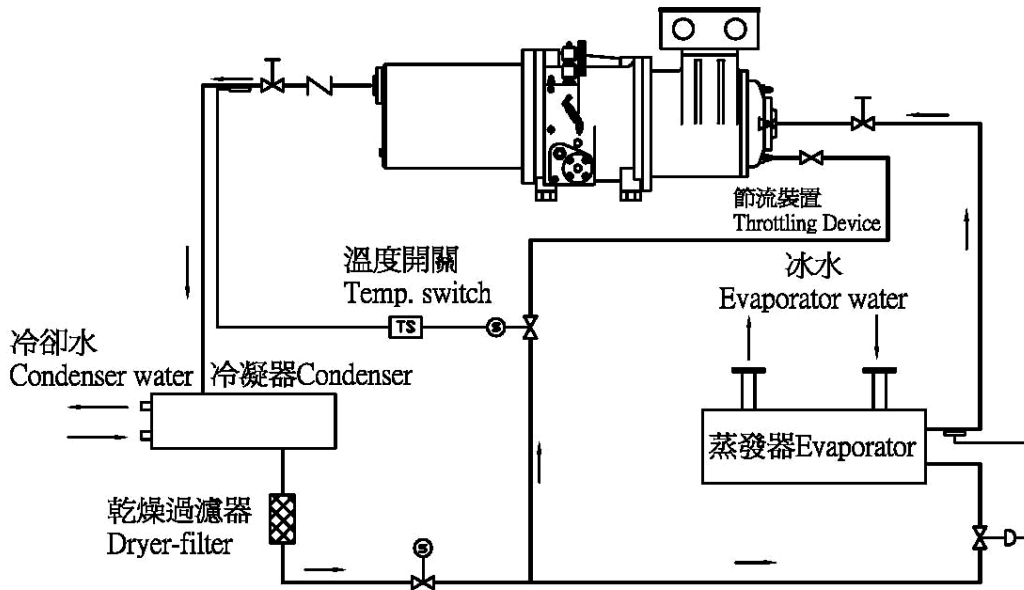

液噴射 (吸氣端) Liquid injection (Suction end)

6.2 油冷卻器

在風冷及熱泵條件運轉下，使用油冷卻器有其必要性，尤其在排氣溫度超過 100°C 時。油冷卻器之給油溫度條件：50°C ~70°C。基於油冷卻器的容量會隨機組之運轉條件不同而改變，一般建議：

6.2 Oil cooler

Under air-cooled or heat-pump operation, it's essential to add oil cooler, particularly when the discharge temperature is over 100°C. The required outlet oil temperature of oil cooler is 50°C ~70°C, which varies according to the cooler capacity and compressor operation condition. The recommended oil cooler capacity is shown as follows:

機型 Model	SR-1(H)~SR-3(H)	SR-434(H)	SR-4(H)~SR-561(H)	SR-6(H)~SR-7(H)	SR-8(H)
油冷卻器容量 Oil cooler capacity (kW)	14	18	28	35	49
機型 Model	SRA-1~SRA-3	SRA-434	SRA-4~SRA-561	SRA-6~SRA-7	SRA-8
油冷卻器容量 Oil cooler capacity (kW)	9	12	18	23	32

如果油溫過低時，則可設置旁通閥或冷熱混合閥。油冷卻器應用有空氣冷卻法、冷媒冷卻法、水冷卻法等等。無論那種方法均須考慮油壓降(壓降需小於 0.5bar)，以免造成容調動作不良及軸承潤滑不足，排氣溫度於 70°C 以下，旁通閥開通；超過 70°C，旁通閥關閉使油冷卻器工作。

If the oil temperature is too low, install an oil bypass valve or mixing valve (mix up cold & hot oil). The oil cooler can be cooled down by air, refrigerant or water. No matter what cooling method is applied, the maximum pressure drop through the oil cooler shall not exceed 0.5bar. Higher pressure drop could lead to malfunction of capacity control and insufficient lubrication of bearings. Open the bypass valve if the discharge temperature is lower than 70 to bypass the oil back to compressor. Otherwise, close it to lead the oil into oil cooler.

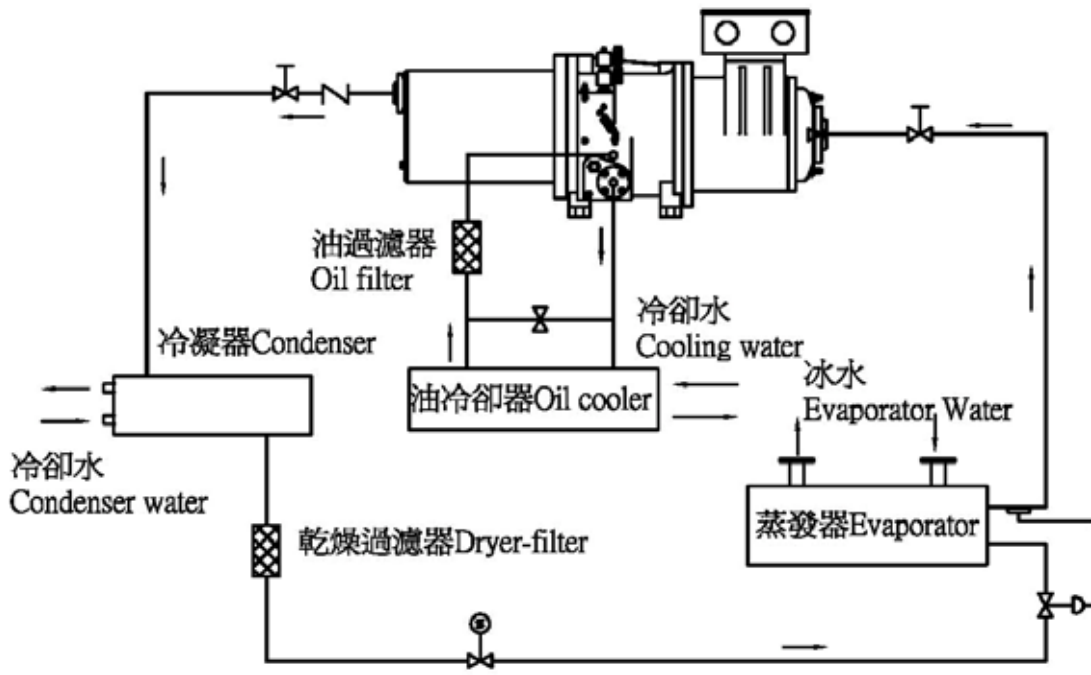

油冷卻器(水冷式) Oil cooler (Water cooled type)

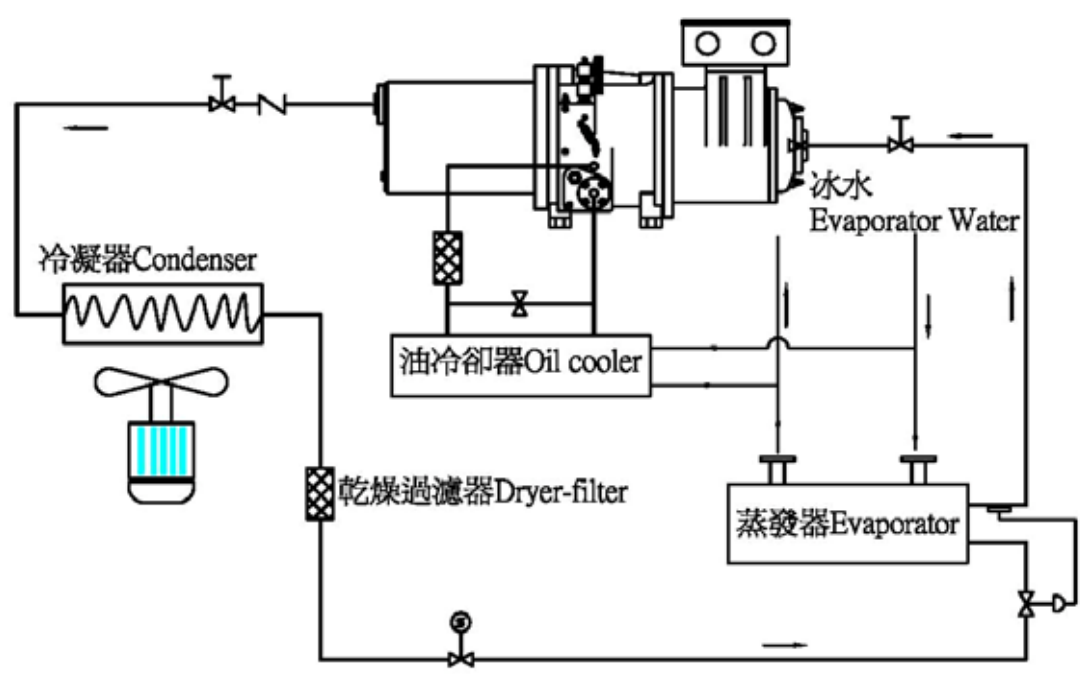

油冷卻器(氣冷式) Oil cooler (air cooled type)

6.3 儲冰空調

一般空調冰水機的蒸發溫度約 0~5 °C，而儲冰之蒸發溫度約 -5°C ~ -15°C (依儲冰方式而異)，所以如此一來其壓縮比將提高，易導致排氣溫度保護開關作動。可考慮加裝液噴射或油冷卻器，以維持正常之排氣溫度。應用于儲冰系統時除了調整溫控開關、防凍開關、低壓開關、卸載控制器和膨脹閥外，請考慮加裝二次油分離器，確保在儲冰制冰運作下有較佳之回油之效果，而回油管接回至壓縮機低壓側。

6.4 節能器

節能器之應用類似二段壓縮原理，可以提升效率，所以用於高壓縮比下其效益較明顯，(例如儲冰系統)。其系統配置有閃蒸桶(Flash tank)與過冷卻器(Liquid sub-cooler)兩種。請參考下圖。

6.3 Thermal storage system

For air conditioning system the evaporating temperature is about 0~5 ; however, it is about -5 ~ -15 in thermal storage system, which would cause higher compression ratio. The compressor might be tripped due to high discharge temperature by the protection device. Therefore, a liquid injection system or oil cooler is recommended to maintain normal discharge temperature. Except the temperature control switch, anti-freeze switch, low-pressure switch, unload controller and expansion valve have to be adjusted, adding a 2nd oil separator is helpful to provide better oil return effect. The returning oil pipe of separator shall be connected to the low-pressure side of compressor.

6.4 Economizer

The principle of economizer is similar to that of two-stage compression. It can increase the efficiency of compressor especially under high compression ratio condition. The flash tank and liquid sub-cooler system layouts are illustrated as follows:

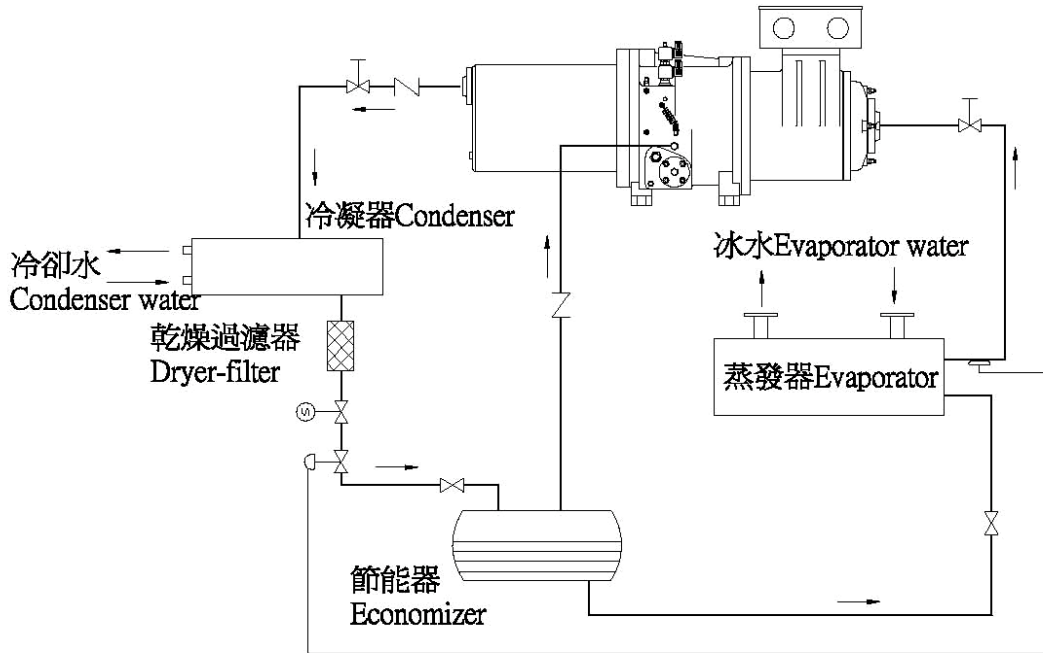

節能器Economizer (Flash Tank Type)

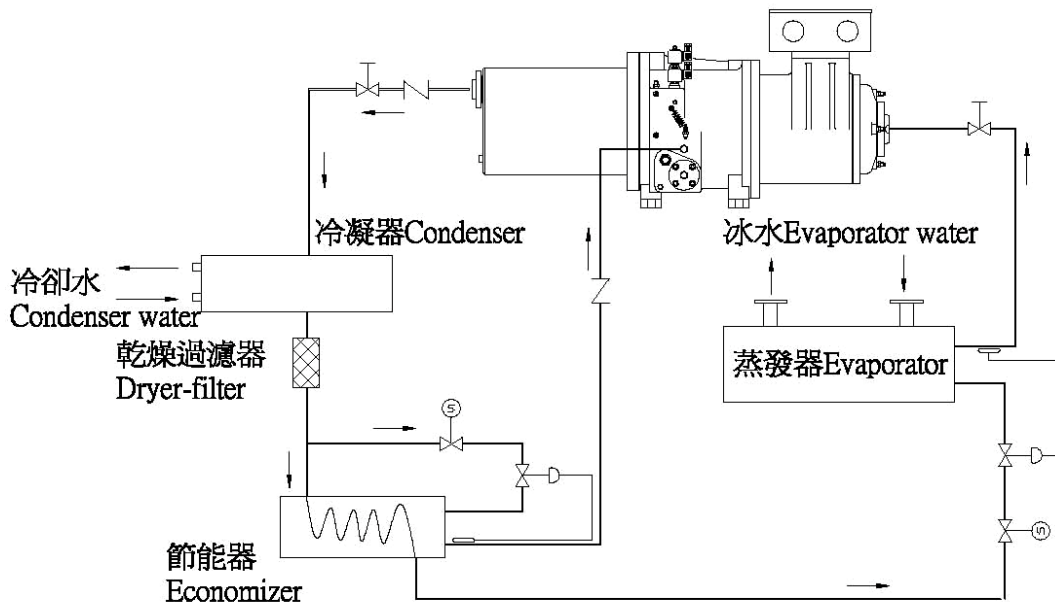

節能器Economizer (Liquid Sub-Cooler type)

7. 產品配件

7.1 配件規格

7.1.1 容調電磁閥

容調電磁閥之控制電壓系採 220V，不得用異於 220V 電壓輸入，若有特殊需求 110V 之控制電壓，請與復盛公司聯繫更換電磁閥線圈。

7.1.2 加熱器

- ◆種類：
150W 或 300W；110V 與 220V 兩種電壓選擇。
- ◆絕緣值：
以 500VDC 高阻計量測絕緣值 50MΩ 以上。

7.1.3 油位開關

- ◆絕緣值：
以 200VDC 高阻計量測，絕緣值 10MΩ 以上；
- ◆最高使用電壓：AC230V
- ◆最高允許電流：0.5A
- ◆乾接點，高液位時閉路；低液位時開路。

7.1.4 馬達及排氣溫度 PTC 控制模組:INT69

- ◆電壓：
230V, 1phase (其他電壓 115V)
- ◆電驛：
AC240, 2.5A, 360VA, 單極雙投，自動復歸。

7.1.5 馬達線圈溫度保護

- ◆量測電阻最高容許電壓: DC 2.5V.
- ◆環境溫度下電阻值：小於 750Ω.
- ◆絕緣強度：600VAC.

7.1.6 排氣溫度保護

- ◆量測電阻最高容許電壓: DC 2.5V
- ◆環境溫度下電阻值：小於 550Ω
- ◆絕緣強度：600VAC

7. PRODUCT SCOPE

7.1 Fittings specification

7.1.1 Solenoid valve

The standard control voltage is 220V. Other voltage is available on request.

7.1.2 Oil Heater

- ◆Model:
150W and 300W; Standard Voltage: 220V. Other voltage is available on request.
- ◆Insulation value:
50MΩ or above measured by 500VDC Mega-ohmmeter.

7.1.3 Oil level switch

- ◆Insulation value:
10MΩ or above measured by 200VDC Mega-ohmmeter;
- ◆Maximum allowable voltage: AC230V
- ◆Maximum allowable current: 0.5A
- ◆Dry contact, High level remain close while open at low level.

7.1.4 PTC control module of motor and discharge temperature: INT69

- ◆Voltage:
230V, 1 phase (115V is available on request)
- ◆Relay:
AC240, 2.5A, 360VA, SPDT, auto reset.

7.1.5 PTC thermistor of motor winding protection

- ◆Maximum allowable voltage for measuring resistance: DC 2.5V ;
- ◆Resistance under ambient temperature: less than 750Ω ;
- ◆Insulation strength: 600VAC.

7.1.6 PTC thermistor for discharge temperature protection

- ◆Maximum allowable voltage for measuring resistance: DC 2.5V;
- ◆Resistance under ambient temperature: less than 550Ω ;
- ◆Insulation strength: 600VAC

7.2 配件明細

7.2 Fittings list

序號 No.	配件名稱 Description	機型 Model		
		SR(A)	SR-H	SF(A)
1	排氣法蘭、墊片、擋板 Discharge flange, gasket and flange plate	√	√	√
2	進氣法蘭、墊片、擋板 Suction flange, gasket and stopper	√	√	√
3	進氣濾清器 Suction filter	√	√	√
4	油過濾器 Oil strainer	√	√	√
5	電磁閥三只(起動與容調用) Solenoid valve (3 pieces) (startup and capacity control)	√	√	√
6	馬達線圈溫度保護器 Motor winding temperature protector	√	√	√
7	冷凍油 Refrigeration oil	√	√	√
8	油加熱器 Oil heater	√	√	√
9	油位開關 Oil level switch	√	√	√
10	排氣高溫保護開關 Discharge temperature protector	√	√	√
11	洩油閥 Oil draining valve	√	√	√
12	壓縮室節能器噴射口 Economizer injection port-compression chamber	√	√	√
13	馬達端液噴射口 Liquid injection port - motor side	√	√	√
14	油冷卻器外接迴路 External oil cooler connecting port	—	√	—
15	非石棉墊片 Non-asbestos gasket	√	√	√
16	排氣端止回閥 Discharge check valve	√	√	√
17	排氣端安全閥 Discharge safety valve	△	△	△
18	進氣端關斷閥 Suction service valve	△	△	△
19	排氣端關斷閥 Discharge service valve	△	△	△
20	防震墊 Anti-vibration pad	△	△	△
21	液冷媒噴射用毛細管 Liquid refrigerant injection capillary tube	△	△	△

√：標準配備 △：選用配備 —：無此配置

√：Standard, △：Optional, —：Not applicable

7.3 潤滑油

7.3 Lubricant

HCFC/R-22

冷凍油特性 Lubricant characteristics	油品名稱 Lubricant			
	CP-4214-150	CP-4214-320	SUNISO 4GSD	SUNISO 5GSD
黏度(viscosity) cst@40°C ASTM D445	168	298	54.9	94.6
黏度(viscosity) cst@100°C ASTM D445	20.2	32	5.97	7.78
黏度指數 (viscosity index) ASTM D2270	150	149	0	37
比重 (Specific weight) ASTM D1298/D1250	1.01	1.05	0.916	0.918
流動點 (Flow point)(°C) ASTM D97	-43	-35	-35	-27.5
閃火點(Flash point) (°C) ASTM D92	290	271	188	208
耐電壓強度 (Voltage strength) (kV) ASTM D877	42.0	42.5	>30	>30

HFC/R-134a/R-407C

冷凍油特性 Lubricant characteristics	油品名稱 Lubricant	
	SOLEST-68	SOLEST-120
黏度(viscosity) , cst@40°C ASTM D445	66.3	127.7
黏度(viscosity) , cst@100°C ASTM D445	8.9	12.7
黏度指數(viscosity index) ASTM D2270	108	90
比重(Specific weight) ASTM D4052	0.957	0.951
流動點(Flow point) (°C) ASTM D97	-43	-33
閃火點(Flash point) (°C) ASTM D92	263	251
耐電壓強度(Voltage strength) (kV) ASTM D877	49.4	47.0

7.4 噪音值

7.4 Noise level

SR Sound pressure level (dBA)									
Model Hz	SR-1	SR-2	SR-3	SR-434	SR-4	SR-5	SR-6	SR-7	SR-8
50	35.4	29.5	32.8	31.7	30.3	36.4	33.3	32.7	40.8
63	42	36.1	41.9	40.9	34.2	45.6	38.3	34.7	46.7
80	44.2	40.8	52.4	43.7	35.8	48	37.6	39.5	39.5
100	46.6	41.3	47.6	44.8	40.6	50.2	40.6	41.8	42.1
125	54.6	44.3	49.6	47.4	44.5	53	46.7	48.1	49.4
160	53.3	49.2	52.6	55.8	54.1	49.6	46.9	45.1	50.1
200	54.3	52.6	55.6	53.9	50.4	50.2	54.7	54	58.9
250	55.2	57.7	54	60	65.8	61.9	79.3	77.1	78.9
315	58.1	57.9	53.3	57.9	56.5	57.9	58.6	58.2	82.3
400	62.1	60.1	60.1	63.8	57.2	59.1	64.5	57.9	78.9
500	62.2	68.7	68.7	66.8	74	77.8	72.7	64.4	79.7
630	62.1	62.3	66.9	67.5	68.7	63.9	67	66.7	69
800	65.3	69.7	69.6	73.8	71.6	72.4	72.5	74.6	79.8
1000	70	70.6	71.2	75.6	76.8	68.1	69.7	82.4	83.4
1250	70.9	76.2	73.5	73.9	75.1	73	75.8	73.5	81
1600	67.3	69.6	71.4	74.3	73.5	69	69.9	68.4	74.8
2000	64.2	64.1	63	73.6	78.1	81.5	79.3	72.4	75.9
2500	61.2	63.8	65.3	68.7	70.6	69.2	70.6	70	75
3150	60.2	58.2	61	64	64.8	62	65.7	61	62.4
4000	59.7	56	56.1	58.9	58.6	60	64.3	59.2	60.8
5000	56.1	58.6	51.9	60.7	56.5	61.1	60.1	58.5	68.7
3600	54.5	56.4	48.4	55.8	52.9	58.1	57.9	54.7	58.9
8000	51.1	5.7	45.3	52.9	51	54.8	53.9	52	57.6
10000	46.2	48.6	42.4	49	47	52	49.7	47	54.5
12500	44.4	48	40.3	47.7	44.5	46.5	45.9	42.7	48.8
16000	41.4	46.1	38.4	35.6	40.6	40.1	43.1	38.8	47.4
20000	38.4	39.4	34.9	39.8	37.2	34.7	39.2	33	55
總值(overall dBA)	76.50	79.57	79.06	82.11	83.72	84.36	84.66	85.09	89.92

◆ 距離壓縮機體 1m 處測量，運轉條件：冷凝溫度 50°C, 蒸發溫度 0°C.

◆ 其他冷媒如 R-134a 以及 R407C 或運轉條件下噪音值變化在 ±2 dBA 以內.

◆ 噪音量測標準根據 ISO2151.

◆ The above 1/3 octave data are based on condensing temp. at 50°C, evaporating temp at 0°C and measured 1-m from the compressor with R-22 refrigerant.

◆ For all other compatible refrigerants such as R-134a, R-407C and other working conditions within the allowed operation range, the sound pressure level varies within ±2dBA.

◆ The above data was measured according to ISO2151.



7.5 尺寸圖

7.5 Dimension diagram

7.5.1 壓縮機外觀尺寸

7.5.1 Compressor outline dimension

Unit: mm

機型 \ 尺寸 Model Dimension	A	B	C	D	E	F	G	H	I	J	K	M	L
SR-1(H),SRA-1,SF(A)-50	440	230	170	520	594	1336	578	260	448	24	235	---	405
SR-2,3(H),SRA-2,3, SF(A)-60,70	460	232	188	518	594	1451	629	317	455	24	235	---	485
SR-434(H),SRA-434	633	250	250	679	632	1440	634	420	277	18	300	699	358
SF(A)-90	633	250	250	679	632	1489	719	420	277	24	300	699	358
SR-4(H)	817	315	225	751	840	1625	749	302	480	24	728	487	542
SRA-4	753	315	225	753	667	1557	749	302	394	24	325	487	478
SF(A)120	753	315	225	715	667	1601	749	302	430	24	325	487	478
SR-5,561(H)	817	315	225	751	840	1657	749	334	480	24	728	487	542
SRA-5,561	750	315	225	753	672	1589	749	334	394	24	325	487	475
SF(A)140,160	750	315	225	742	672	1633	749	334	430	24	325	487	475
SR-6(H)	860	340	255	754	866	1722	848	284	561	26	754	530	577
SRA-6	817	340	255	757	667	1724	848	284	480	26	325	530	513
SF(A)-180	817	340	255	714	667	1734	848	284	480	26	325	530	513
SR-7(H)	858	340	255	754	866	1753	848	319	561	26	754	530	577
SRA-7	814	340	255	757	672	1759	848	319	480	26	325	530	510
SF(A)-230	814	340	255	714	672	1769	848	319	480	26	325	530	510
SR-8(H),SRA-8,SF(A)-270	930	310	285	771	747	2023	903	372	675	26	325	595	570

規格如有變更，不另行通知。

The specification is subject to change without notice.

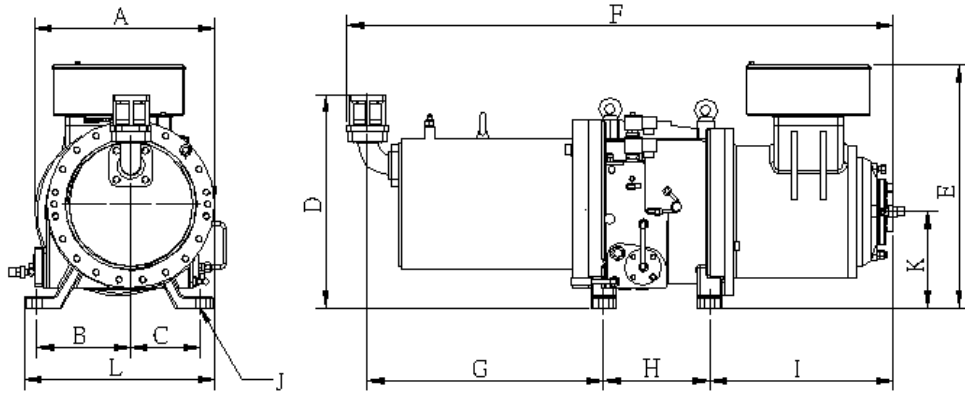

SR(A)-1,2,3(H),SF(A)-50

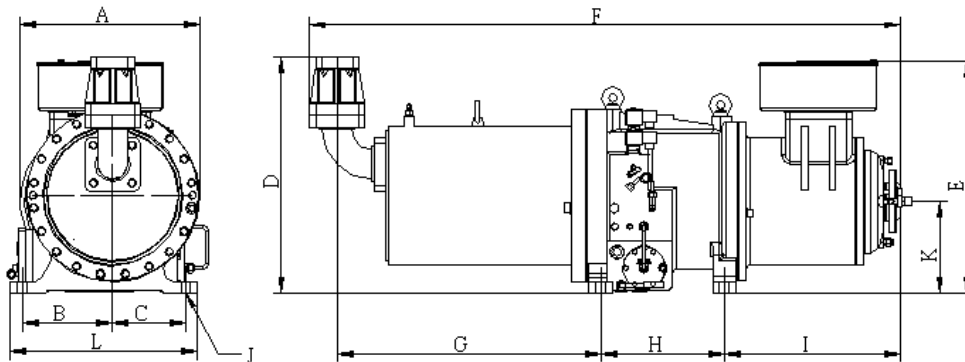

SF(A)-60,70

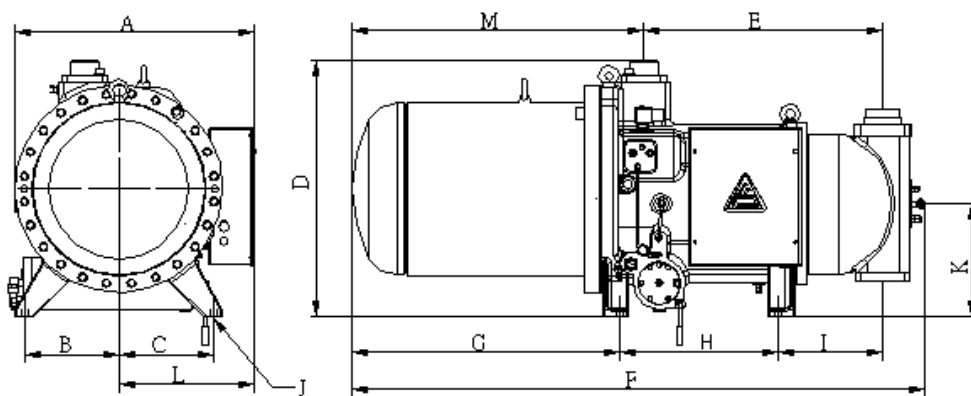

SR(A)-434(H), SF(A)-90

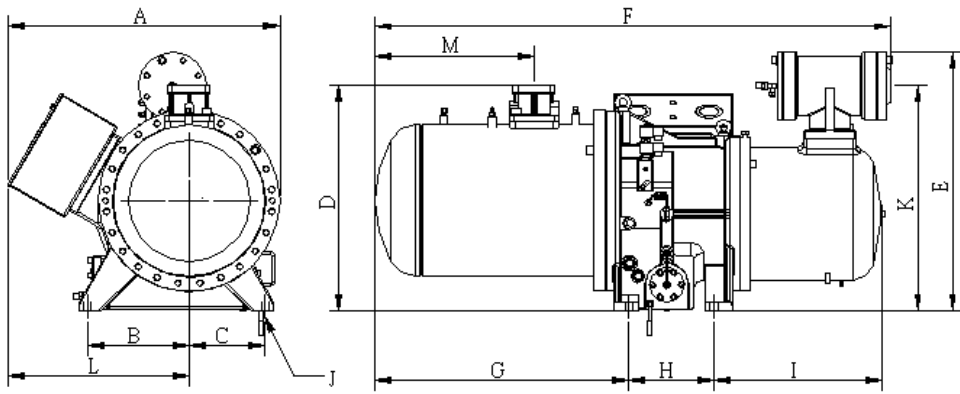

SR-4,5,561,6,7(H)

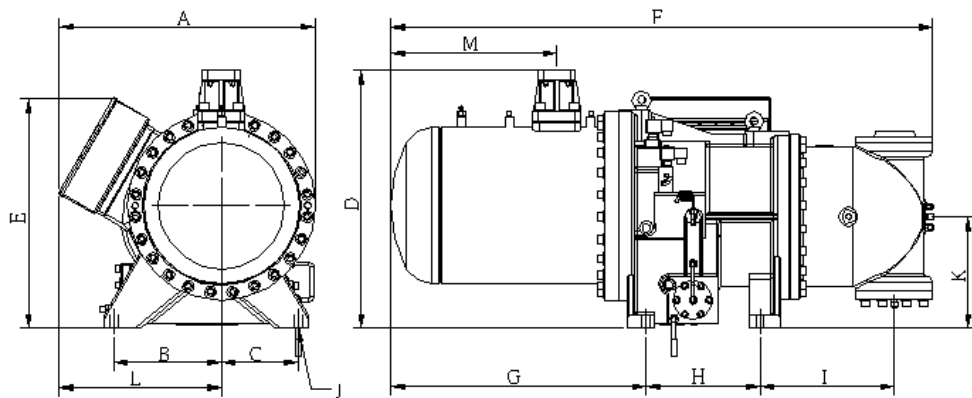

SRA-4,5,561,6,7
SF(A)-120,140,160,180,230

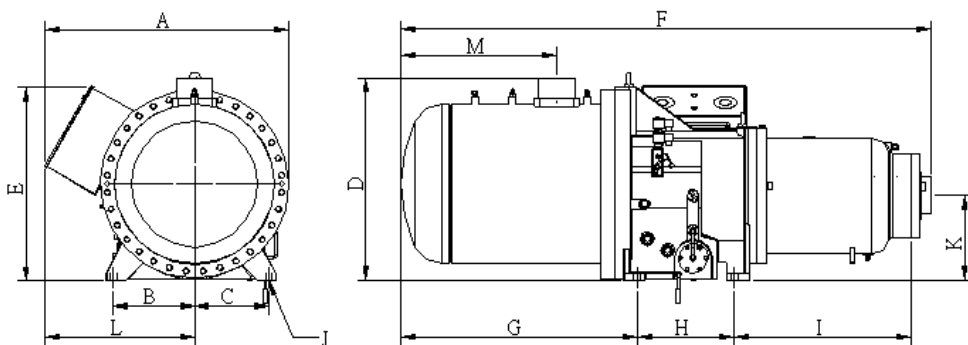

SR(A)-8(H), SF(A)-270

7.5.2 關斷閥尺寸

7.5.2 Service valve dimension

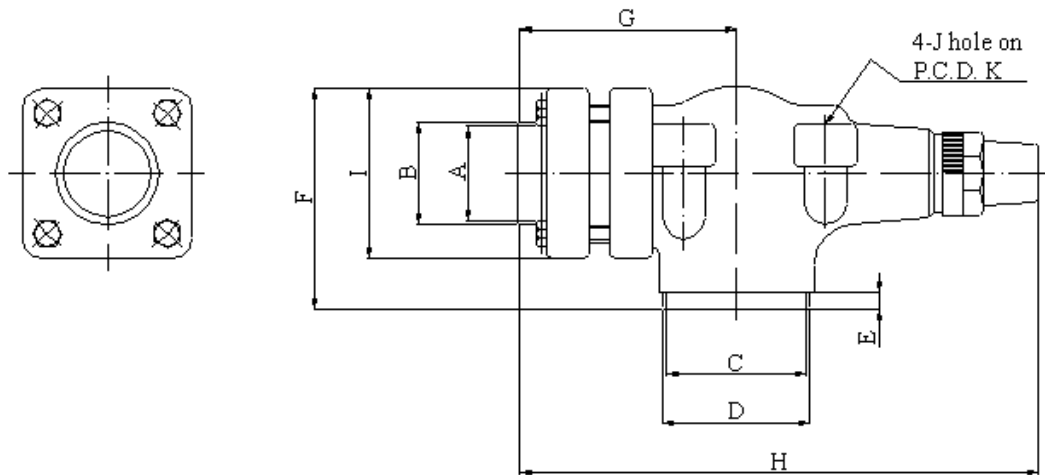

關斷閥 Service valve

Unit: mm

型式 Type	1-5/8"	2-5/8"	3-1/8"	3-1/2"	4"	5"
A	42	2-5/8"	3-1/8"	3-1/2"	4"	5"
B	49	77	89	101.5	114.5	131
C	54	64	85	98.6	111.1	126
D	70	81.5	105.5	115.5	130	130
E	8	10	8	8	5	4
F	105	118	147	190	210	294
G	110	137	166	185	205	224
H	254	310	355	420	450	429
I	81	110	142	155	169	230
J	13.5	18	18.5	17	20.5	18
K	89.8	110	140	152.4	173	194

型式 Type	吸氣端關斷閥 Suction service valve	排氣端關斷閥 Discharge service valve	
SR-1(H)	2-5/8"	1-5/8"	
SR-2(H)			
SR-3(H)			
SR-434(H)			
SR-434II(H)	3-1/8"	2-5/8"	
SR-4(H)	4"		
SR-5/561(H)			
SR-6(H)			3-1/8"
SR-7(H)			3-1/8"
SR-8(H)	5"	4"	
SF(A)-50	2-5/8"	1-5/8"	
SF(A)-60	3-1/8"	2-5/8"	
SF(A)-70			
SF(A)-90			
SF(A)-120	4"	3-1/8"	
SF(A)-140/160			
SF(A)-180	5"	4"	
SF(A)-230			
SF(A)-270			N/A

7.5.3 排氣法蘭尺寸

7.5.3 Discharge flange dimension

Unit: mm

型號 Model	A	B	C	D	E	F	G	H	P.C.D
SR(A)-1~3(H), SF(A)-50	46	41.5	58	70	6	15	26	-	90
SR(A)-4,5,561(H) SF(A)-60/70	77.2	66	90	110	6	24	40	-	140
SF(A)-120/140/160	92.5	90	-	130	6	26	45	-	170
SR(A)-8(H), 180/230	115	100	130	140	6	-	90	-	170
SR(A)-434(H), SF(A)-90	76	67	60	90	6	20	20	60	110

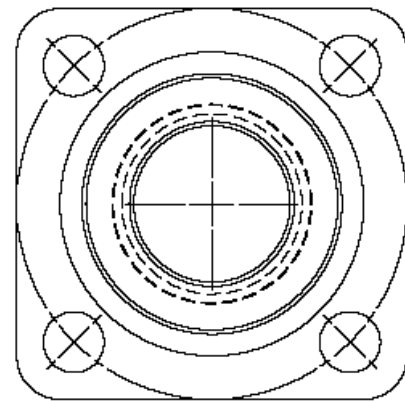
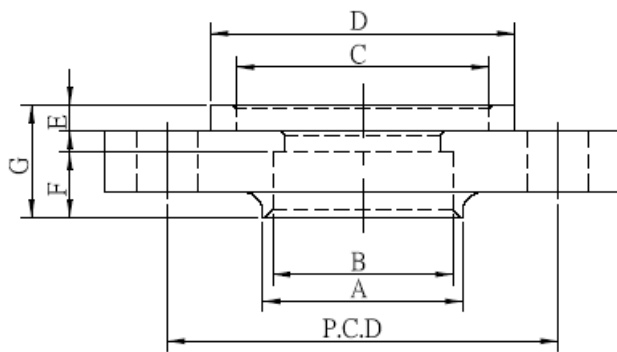

排氣法蘭 Discharge flange of SR(A)-1~3(H), SF(A)-50

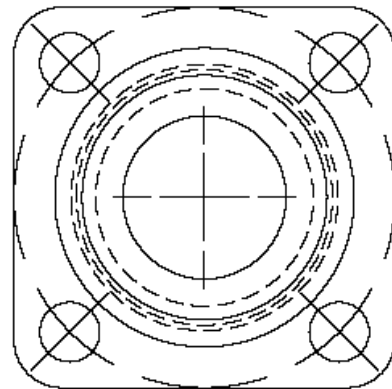
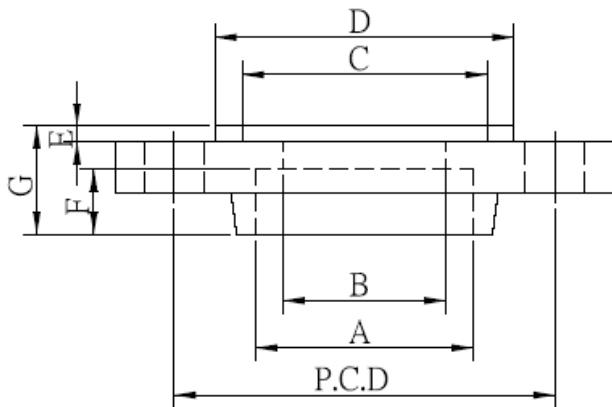

排氣法蘭 Discharge flange of SR(A)-4~7(H), SF(A)-60,70,120,140,160

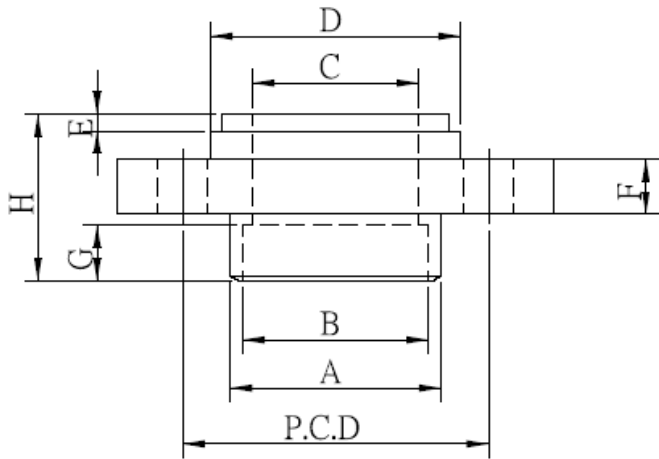

排氣法蘭 Discharge flange of SR(A)-434(H), SF(A)-90

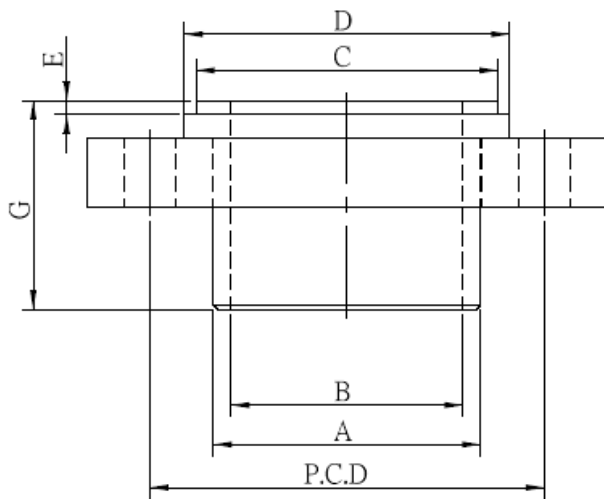

排氣法蘭 Discharge flange of SF(A)-8H, SF(A)-180/230

7.5.4 進氣法蘭尺寸

6.Suction flange dimension

型號 Model	A	B	C	D	E	F	G	H	P.C.D
SR(A)-1~3, SF(A)-50	65	54	50	98	5	20	25	40	130
SF(A)-60/70	90	80	75	98	5	20	25	35	130
SR(A)-4/5/561/6/7(H)	112	92.5	90	145	6	26	33	48	185
SF(A)-120/140/160/180/230	130.7	142	110	145	6	18	26	50	185
SR(A)-8/SF(A)-270	140	131	126	211.5	9	35	30	80	260
SR(A)434/SF(A)-90	93	80	76	110	5	35	73	-	140

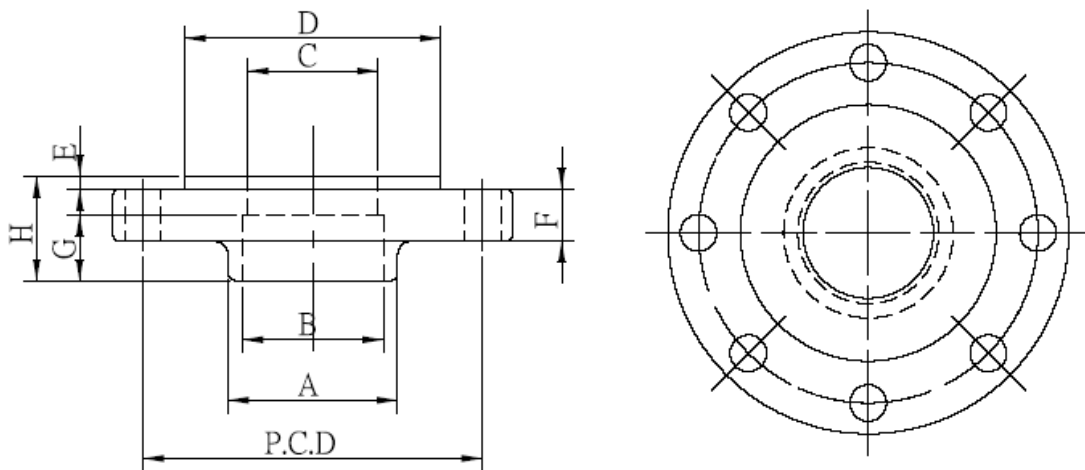

進氣法蘭 Suction flange of SR(A)-1~3(H), SF(A)-50~70

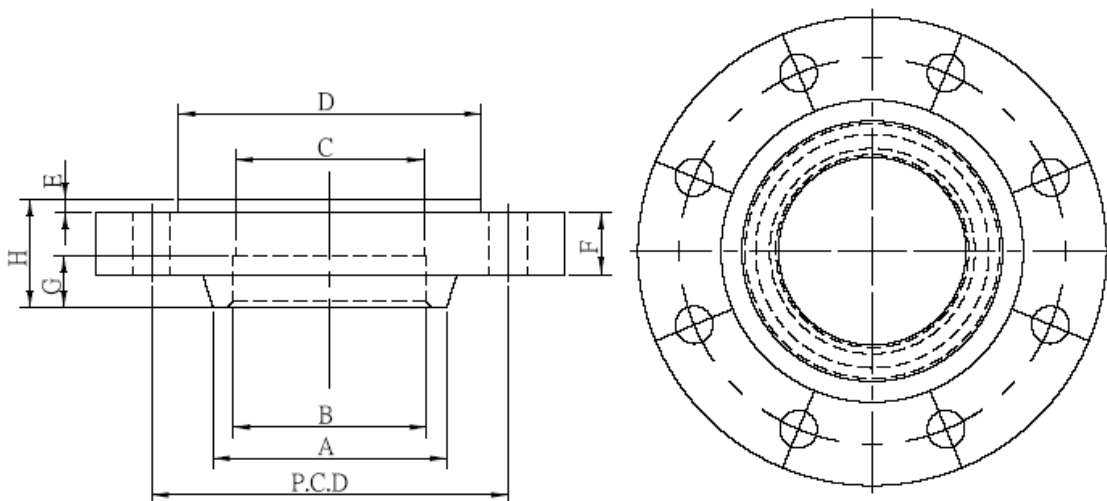

進氣法蘭 Suction flange of SR(A)-4~7, SF(A)-120~230

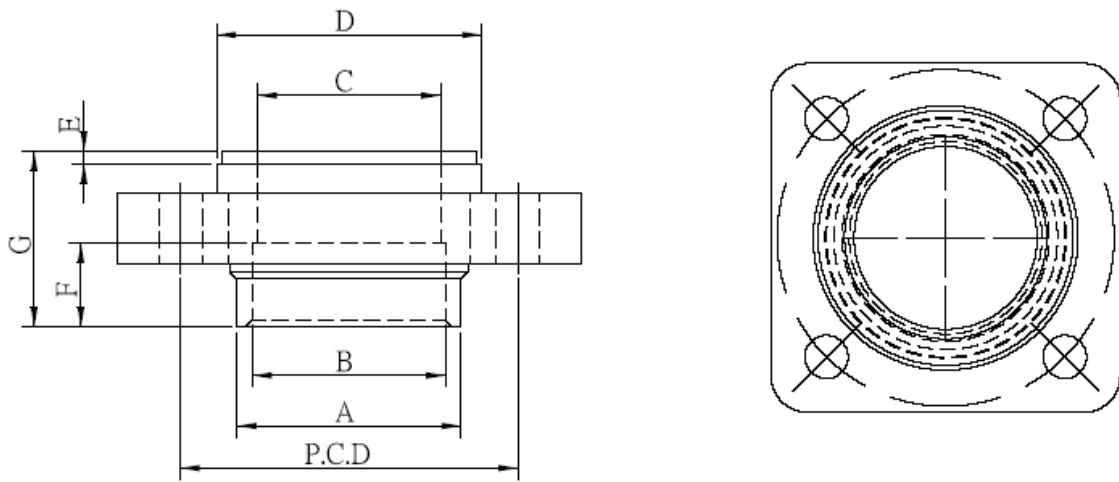

進氣法蘭 Suction flange of SR(A)-434(H), SF(A)-90

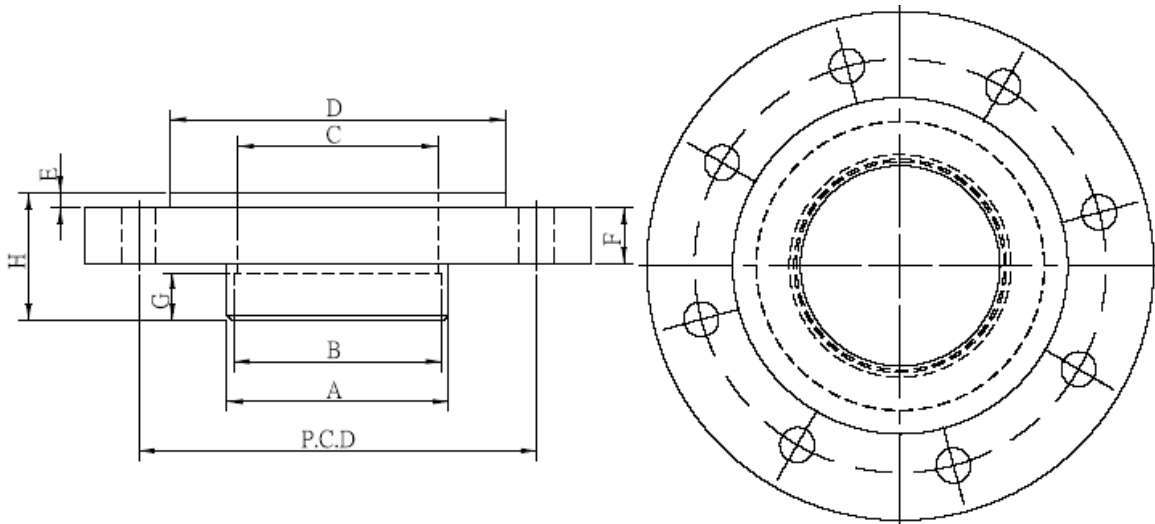

進氣法蘭 Suction flange of SR(A)-8(H), SF(A)-270

7.6 運轉範圍

7.6 Range of operation

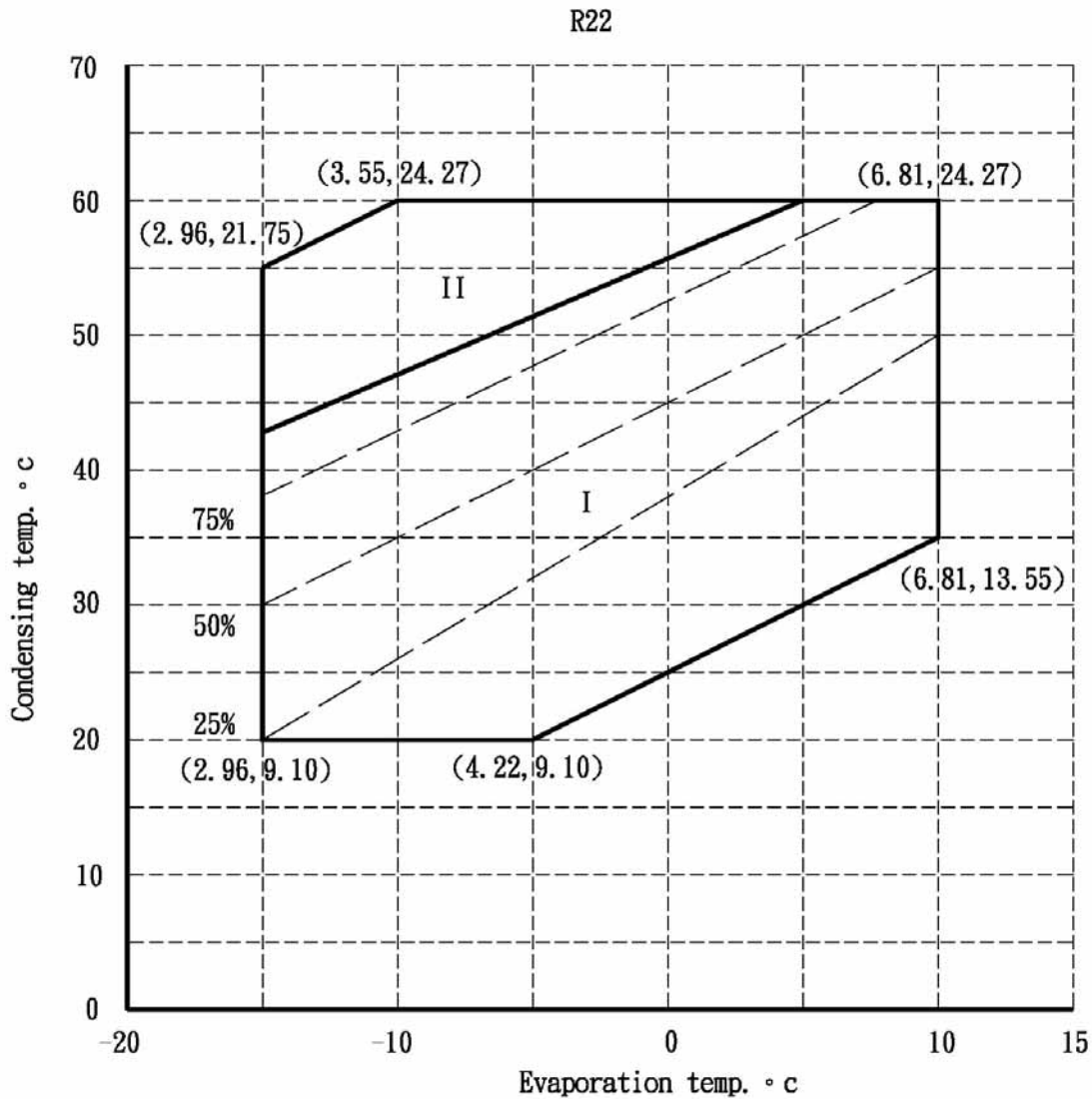

1. (X,Y) 即表示:
 X: 為蒸發壓力 Bar(a)
 Y: 為冷凝壓力 Bar(a)
2. 各運轉範圍說明:
 區域 I:
 壓縮機允許運轉範圍.

區域 II:
 壓縮機允許暫時運轉之操作範圍(長期運轉需加外部冷卻).

1. (X,Y) indicate:
 X: Evaporating pressure Bar(a)
 Y: Condensing pressure Bar(a)
2. Range of application :
 Area I :
 Allowed operation range without additional cooling device.
 Area II :
 Allowed operation range with additional cooling device.



R-134a

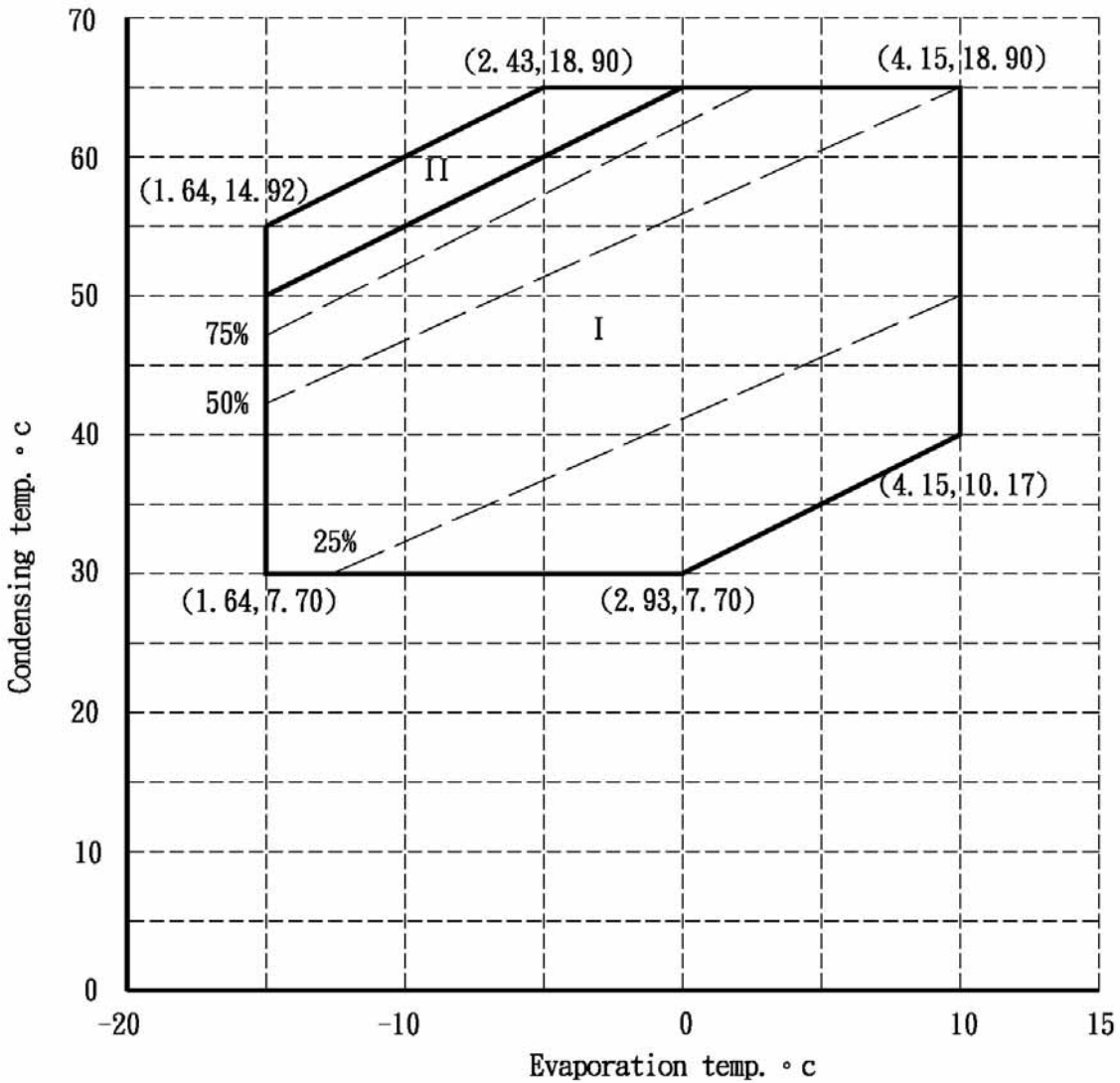

- (X,Y) 即表示:
X: 為蒸發壓力 Bar(a)
Y: 為冷凝壓力 Bar(a)
- 各運轉範圍說明:
區域 I:
壓縮機允許運轉範圍.

區域 II:
壓縮機允許暫時運轉之操作範圍(長期運轉需加外部冷卻).

- (X,Y) indicate:
X: Evaporating pressure Bar(a)
Y: Condensing pressure Bar(a)
- Range of application:
Area I:
Allowed operation range without additional cooling device.
Area II:
Allowed operation range with additional cooling device.

R-407C

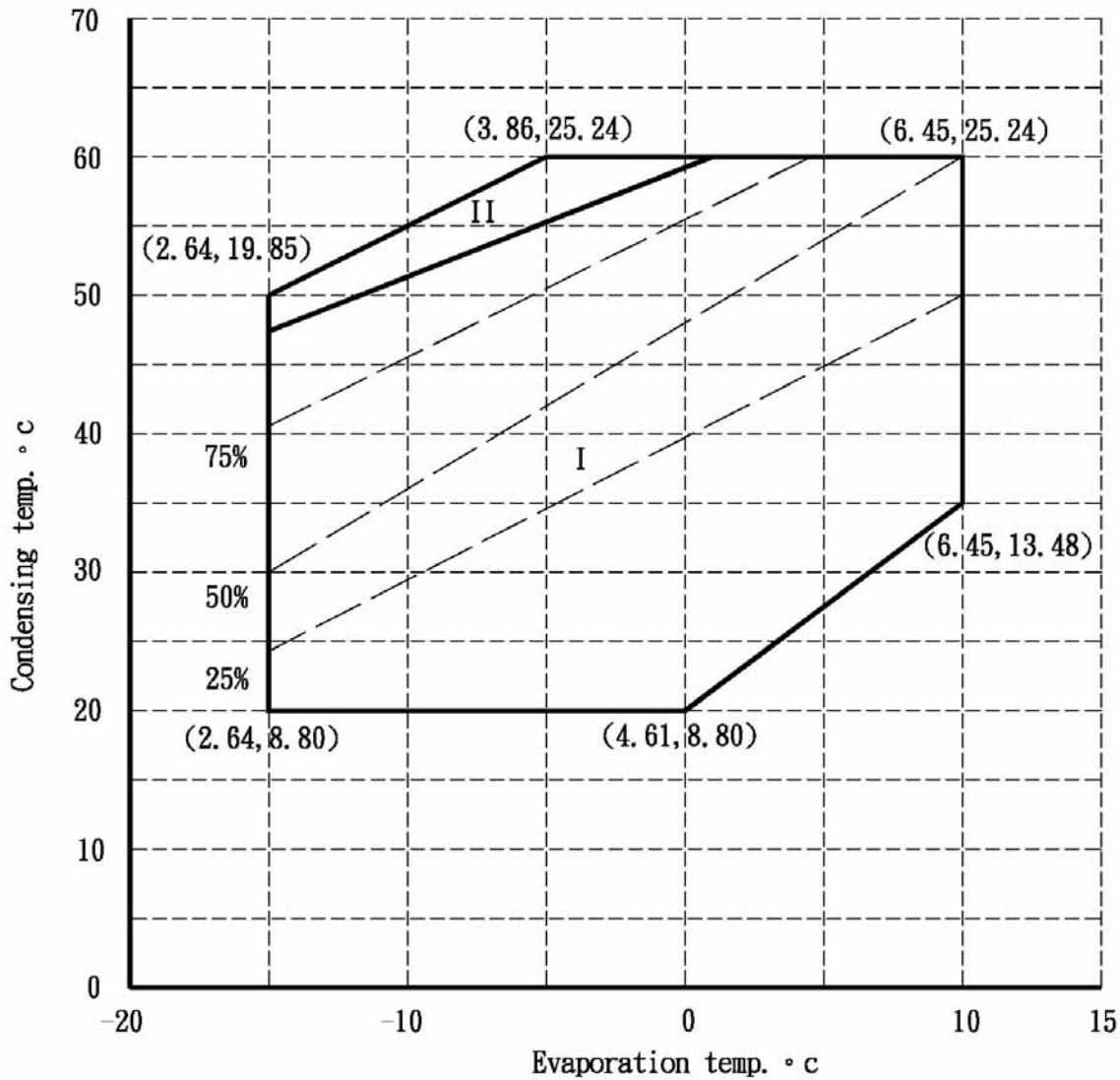

1. (X,Y) 即表示:

X: 為蒸發壓力 Bar(a)

Y: 為冷凝壓力 Bar(a)

2. 各運轉範圍說明:

區域 I:

壓縮機允許運轉範圍.

區域 II:

壓縮機允許暫時運轉之操作範圍(長期運轉需加外部冷卻).

3. 蒸發溫度及冷凝溫度以露點為計算基礎.

1. (X,Y) indicate:

X: Evaporating pressure Bar(a)

Y: Condensing pressure Bar(a)

2. Range of application :

Area I :

Allowed operation range without additional cooling device.

Area II :

Allowed operation range with additional cooling device.

3. Calculation based on dew point temperature.



FU SHENG INDUSTRIAL CO., LTD.

60 KWANG-FU RD., SEC 2.

SAN CHUNG CITY 241, TAIPEI COUNTY, TAIWAN R.O.C.

TEL: +886-2-2995-1411 Website: machinery.fusheng.com

FAX: +886-2-2999-7256 E-mail: machinery@m.fusheng.com.tw

M-SR-EC1-9412