



Hobie® Mirage®  
Outback Manual



In 1950, Hobie's dream was born in his parents' garage when he decided to apply his love of woodworking to the sport of surfing. Dad backed out the Buick... Hobie carved out his very first surfboard...

Hobie's business of fun had begun.

Anatomy .....	5
Assembly .....	6
Mirage® Drive.....	9
Vantage CTW .....	13
On the Water .....	20
Fishfinder Option .....	23
Storage and Transport.....	31
Maintenance and Care .....	34
Safety .....	36
Warranty.....	38



Look for this icon. Online video is available at

[www.hobie.com/support/products](http://www.hobie.com/support/products)

Please read through the instruction manual before using this product



1. Hull
2. MirageDrive 180 Kick Up
3. Vantage CTW Seat
4. Rectangular Hatch and Bin
5. Paddle
6. Cassette Plug
7. Loader
8. Guardian Parts

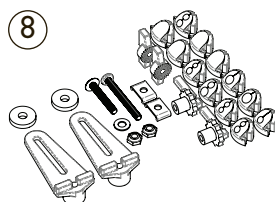
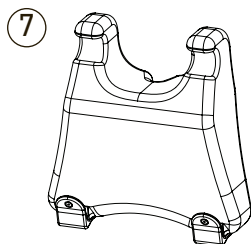
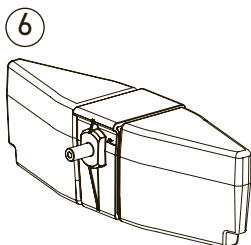
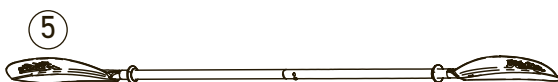
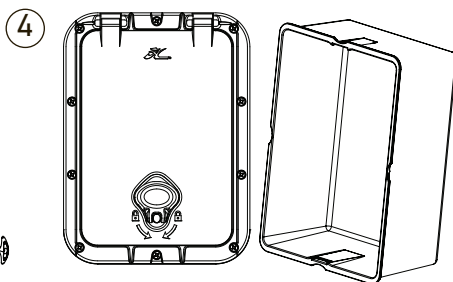
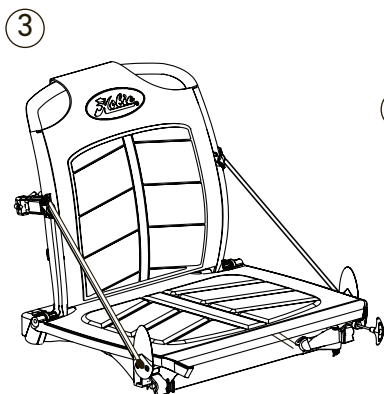
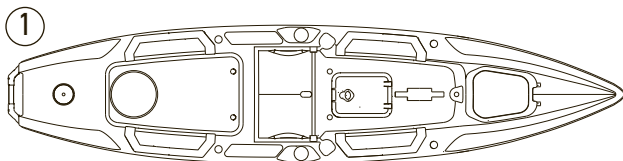
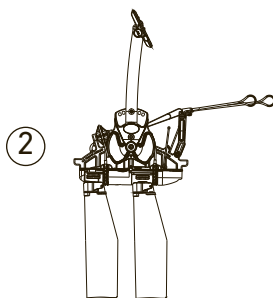

Items not shown to scale  
hobie.com

## MirageDrive Cranks

Depending on the Mirage kayak model, cranks may or may not require assembly.

①

Insert cranks into drums while depressing button at top.

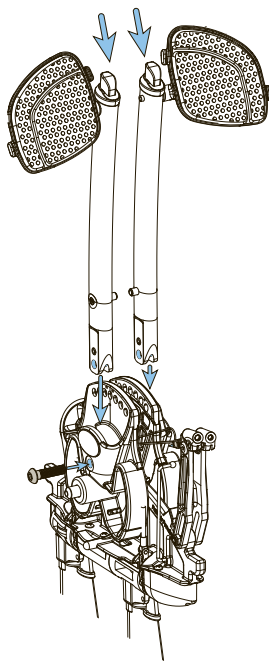

②

Tighten crank bolt all the way using a 7/32" Allen® wrench.

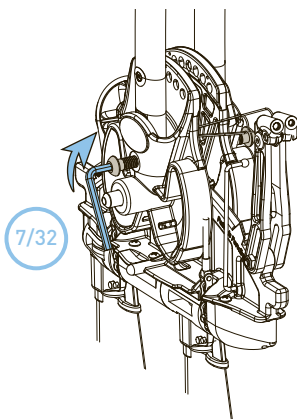

## FWD/REV Handle Installation

①

Line up the shorter (FWD) handle on the left and the longer (REV) handle on the right

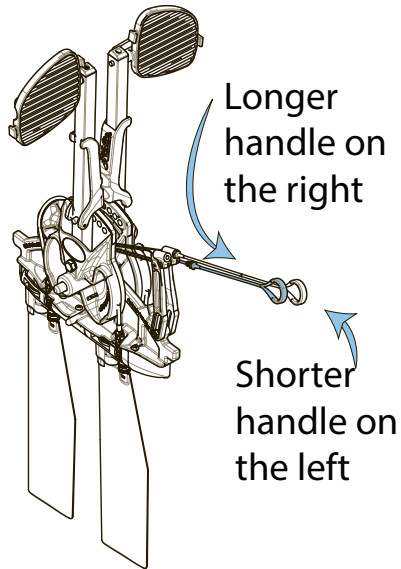

②

Screw in both pull handles into the levers on the MirageDrive

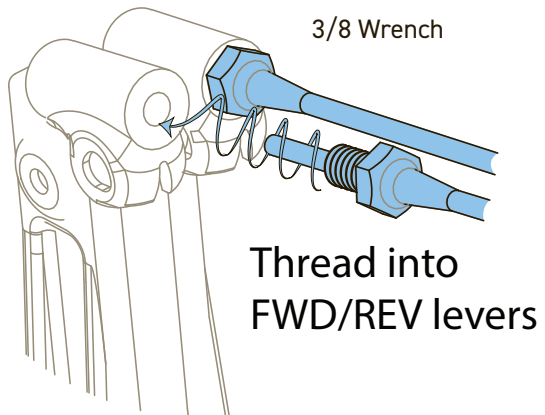

## Installation

①

Lower drive straight down making sure the spine is level

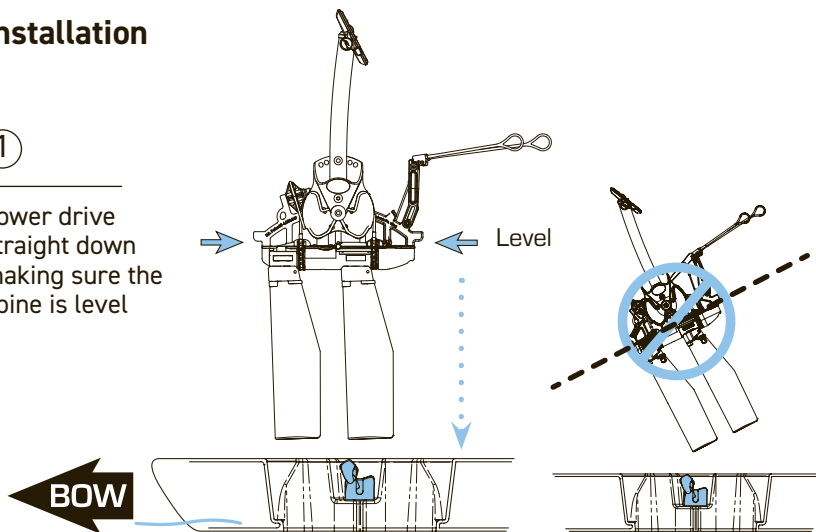

②

Press down and lock drive into Click and Go's. The drive locks automatically when installed.

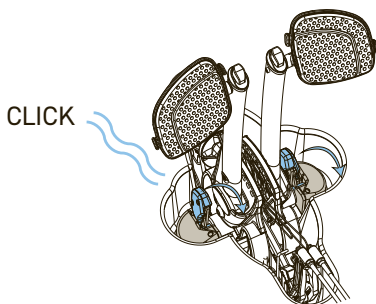

## Removal

①

Pull back each Click and Go lever

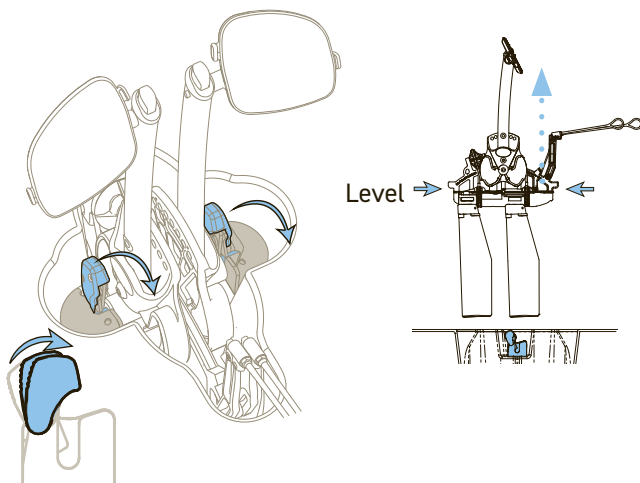

②

Lift drive straight up

## Pedal Adjustment

①

Press the adjuster button at top of crank.

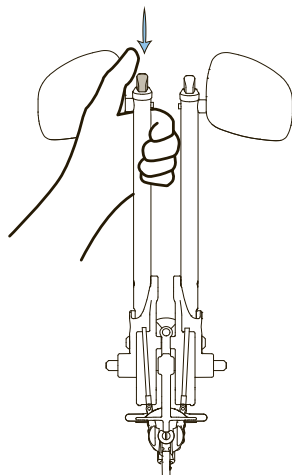

Squeeze

②

Adjust cranks by rotating and clicking them into the desired position. Make sure both cranks are in the same position number.

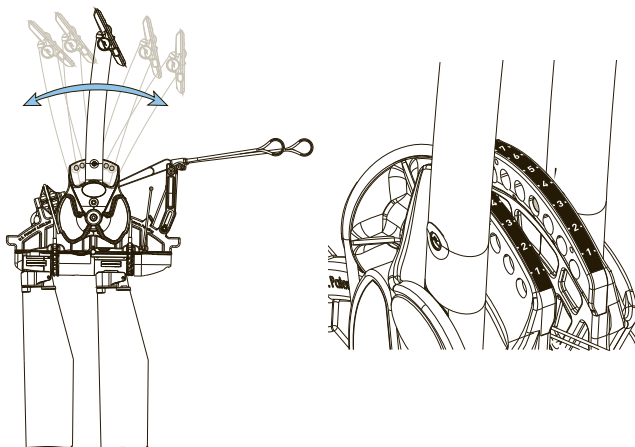

③

With both feet on the pedals and together (fins straight down), your knees should be comfortably bent and not cramped or over extended.

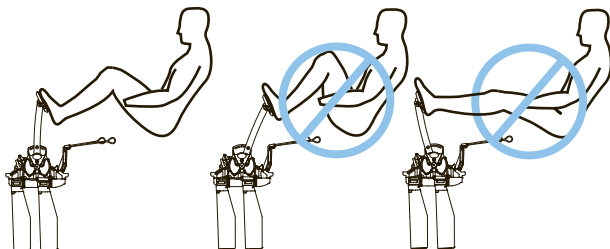

## Reverse



Shifting with the fins too far apart can cause interference with the shift. Pull with firm pressure while cranks are close together.

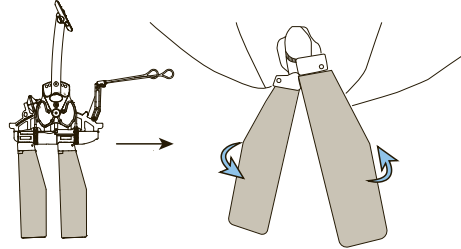
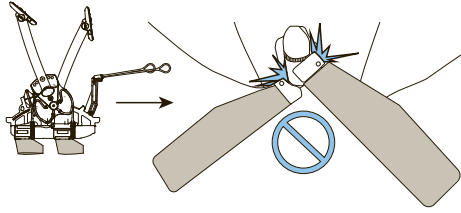

①

From the forward position, pull the right handle to shift the drive into reverse. (This is the longer handle of the two)

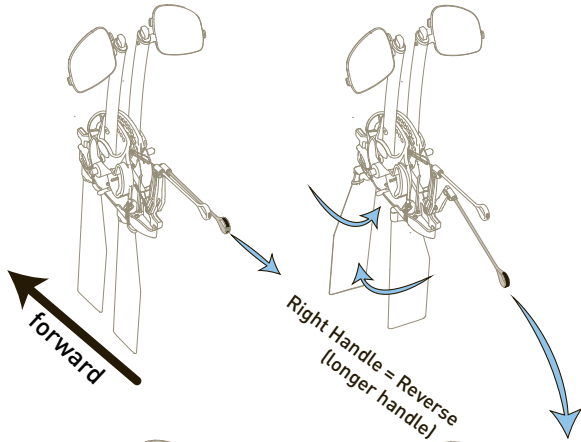

②

From the reverse position, pull the left handle to shift the drive into forward.

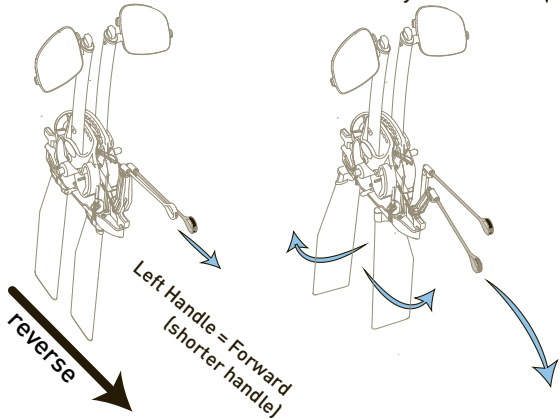

## Kick Up Fin Adjustment

If the fins do not stay locked into position and feel loose, you'll need to adjust the kick-up set screw.

①

The set screw is located in the housing at the base of the fin.

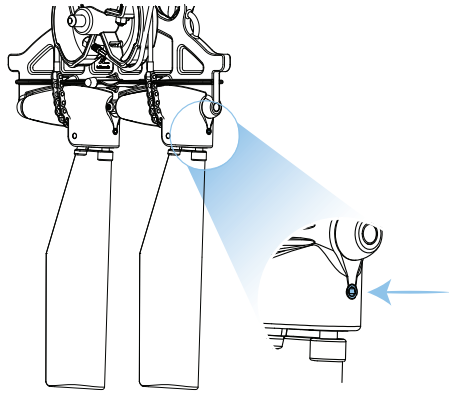

②

Make sure that the fin is completely engaged into the sprocket.

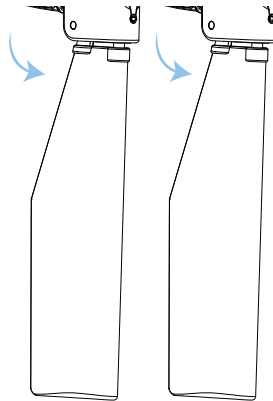

③

Tighten the screw (Phillips or Flat Head Screwdriver) 1/4 turn at a time until the set screw just touches the fin.

Test the fin by moving it in and out of the kick-up position to determine if it needs to be tightened or loosened.

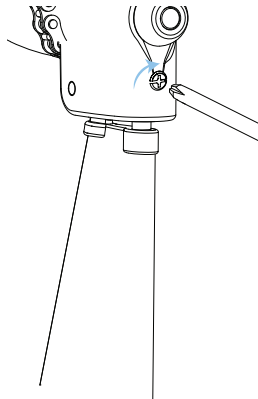

## Vantage CTW Assembly

①

Line up threaded inserts on seat back frame with holes molded in seat bottom frame.

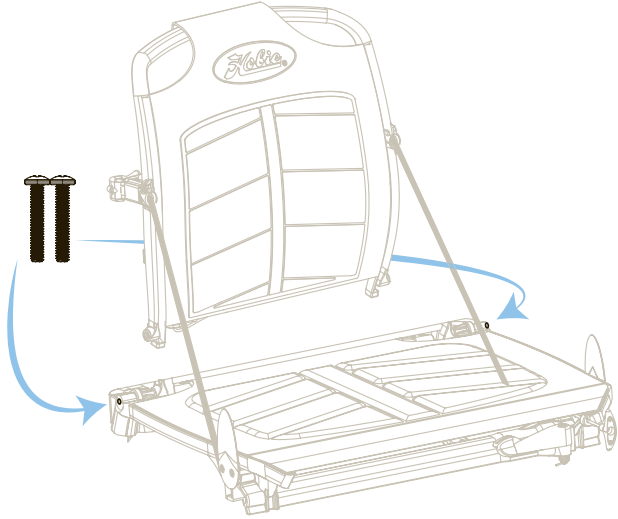

②

Once aligned, insert screws and tighten using a #3 phillips head screwdriver.

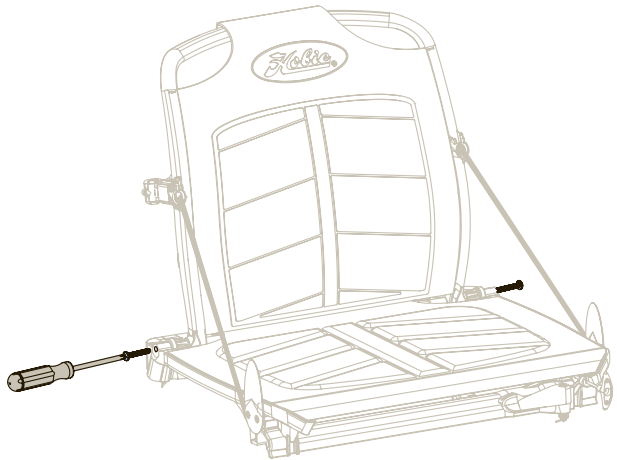



## Anatomy

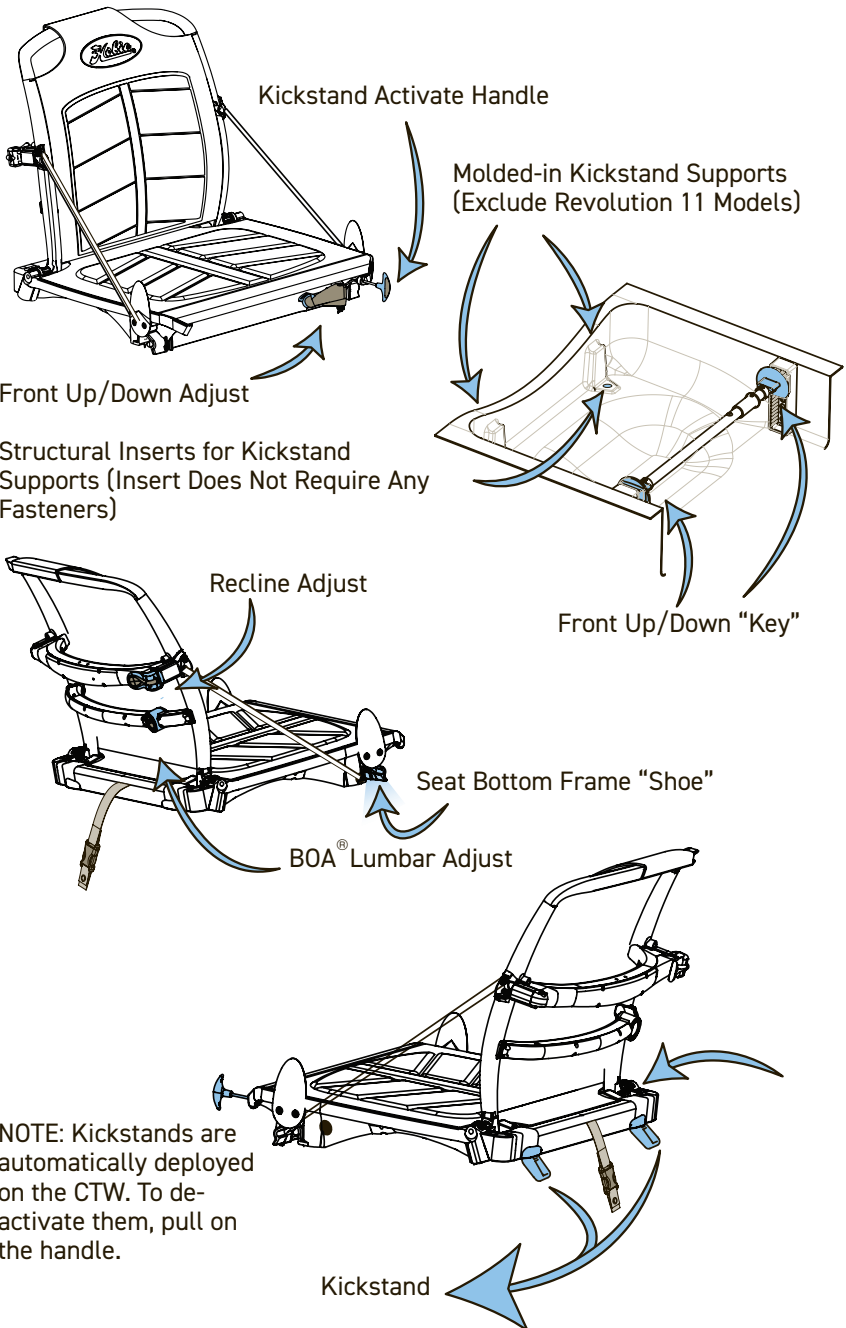

NOTE: Kickstands are automatically deployed on the CTW. To deactivate them, pull on the handle.

## Seat Installation

①

Line up the front of the seat bottom frame over key and slide the back of the frame to the molded-in kickstand supports.

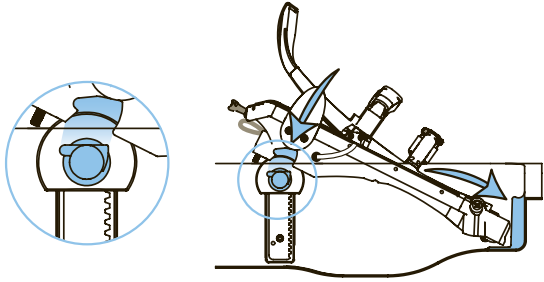

②

Put pressure on the front of the seat mesh & lift the back of the seat bottom frame to set the seat into the key.

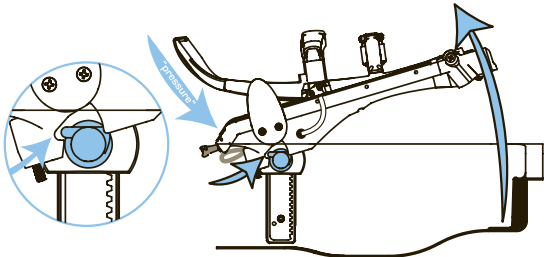

③

Push the seatback frame down once the seat frame is fit into the key. Pull up on front of seat to check for proper installation.

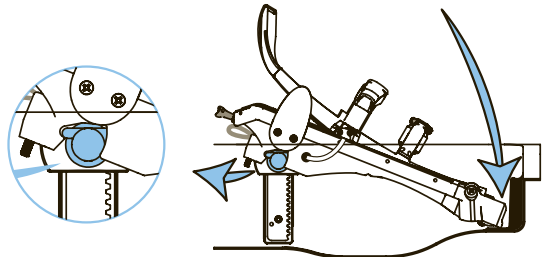

④

Flip seat back up.

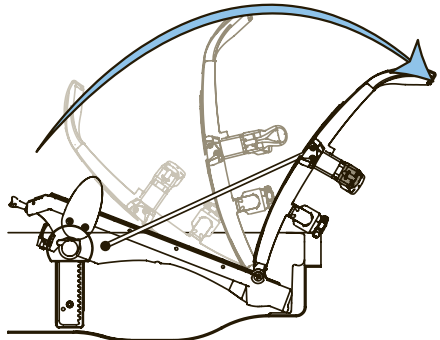

## Seat Installation

5

Locate leash buckle on the seat bottom frame and firewall behind the seat.

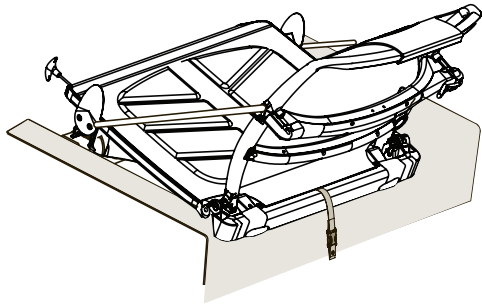

6

Line up and plug in the two parts of the buckle.



7

When the two parts are clicked into place, the seat is secured to the kayak.



8

Pinch to unlock.

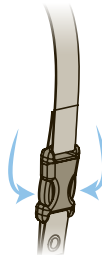

Warning: Failure to secure the seat with the leash buckle could result in loss of seat during a capsized event.

## Front Up/Down Adjustment

①

Pull lever out to activate front up/down adjustment.

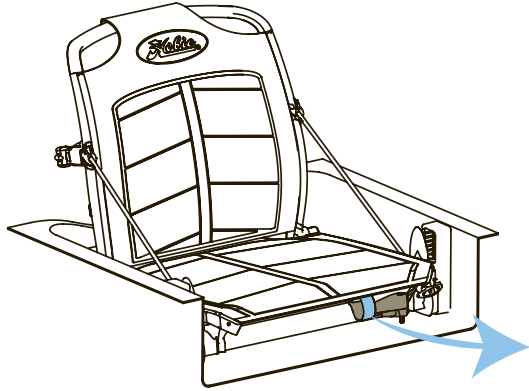

②

Lean back into seat back to raise the front up/down adjustment. Use body weight in seat bottom to drop into a lower position.

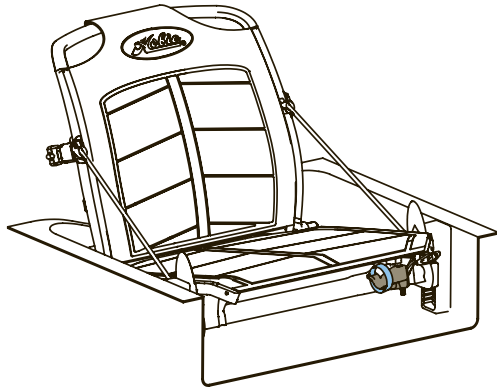

③

Release lever to lock the desired position of the front up/down adjustment.

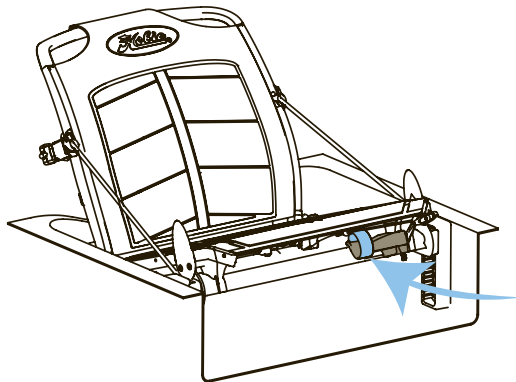

## Rear Up/Down Adjustment

# HIGH

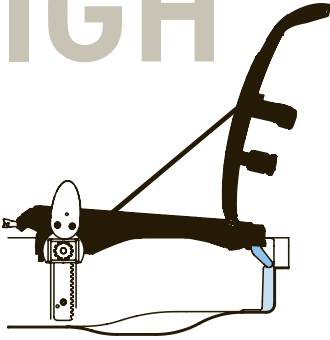

The seat is set to a default high position.

Move weight toward the front of the seat bottom mesh to raise the back of the seat. Pull "T" handle to recline kickstand.

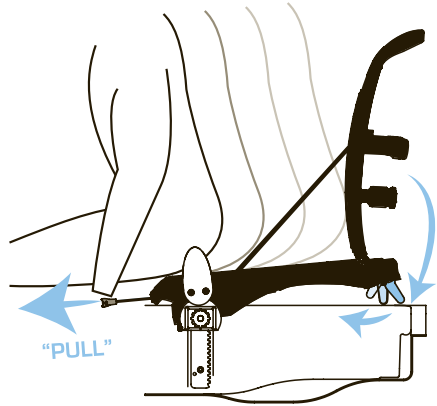

# MID

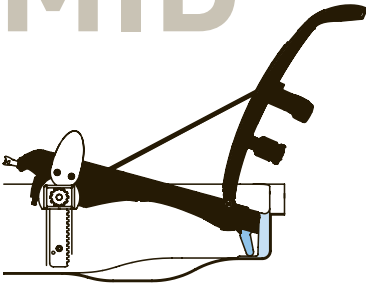

Set kickstand on the boat hull for mid-level seating.

# LOW

Pull "T" handle to retract kickstand away for low position.

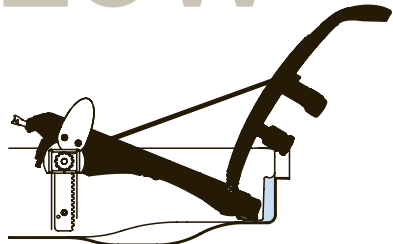

## Recline Adjustment

Pull lever out to activate the seatback to recline.

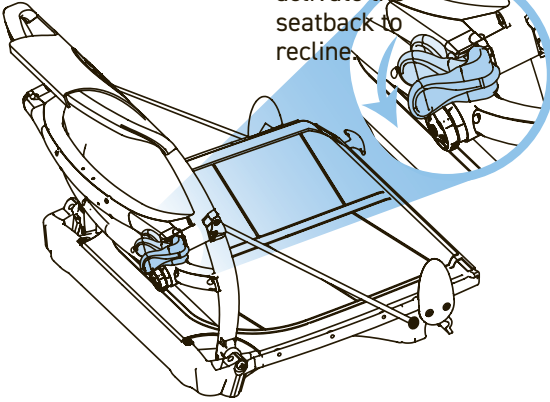

While holding the lever out, push back into the seat to recline.

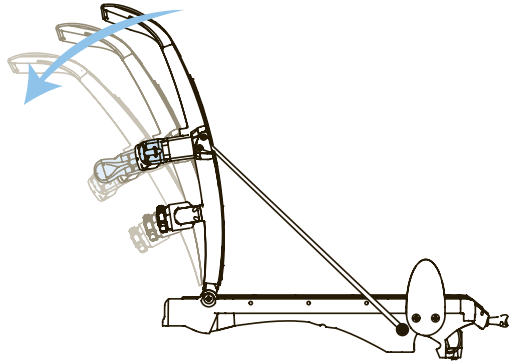

Release lever to lock seat into position.

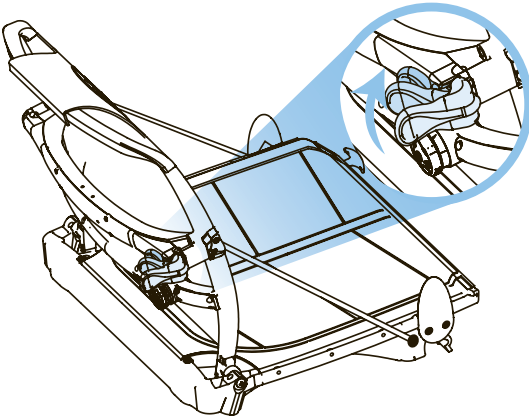

## Lumbar Adjustment

①

Pull knob to release lumbar.

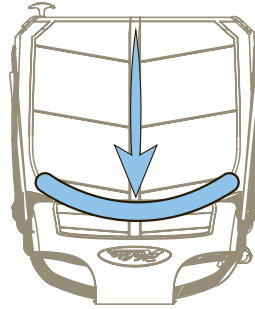
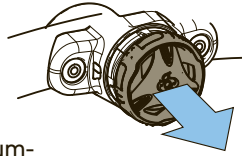

②

Press knob to lock lumbar.

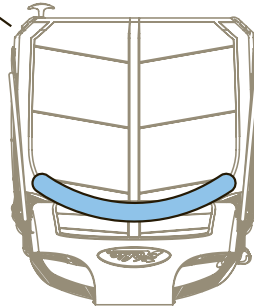
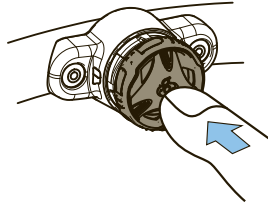

③

Rotate knob clockwise to tension lumbar.

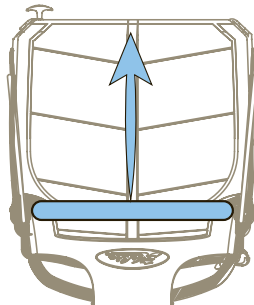
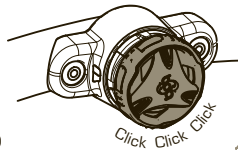

## MirageDrive Operation

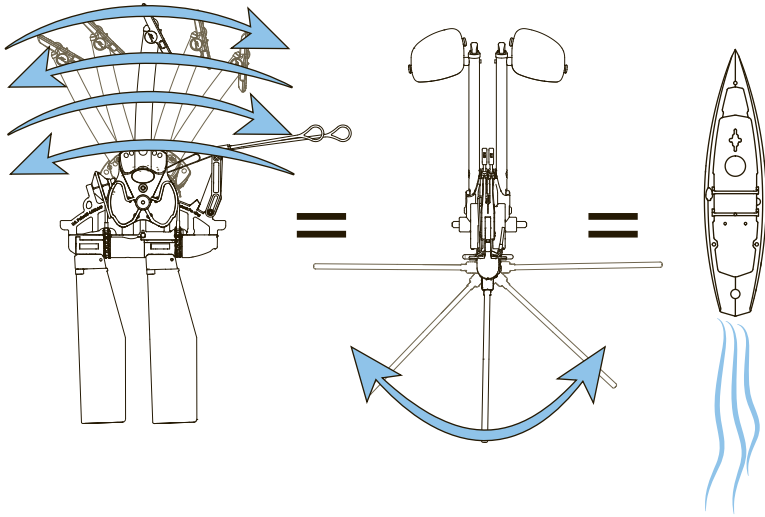

### Shallow Water and Beaching

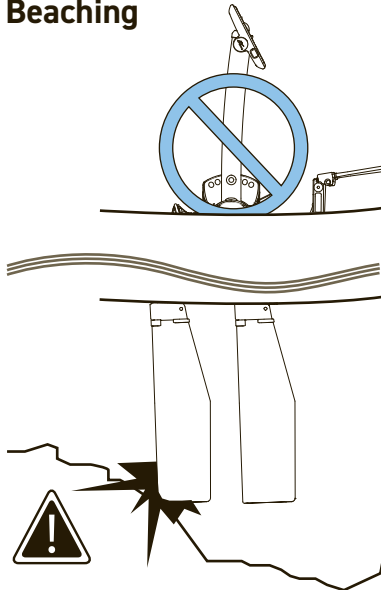

Press either pedal forward in shallow water to raise fins. Pressing one pedal fully forward will orient the fins with the kayak underside.

### Kick Up Fins

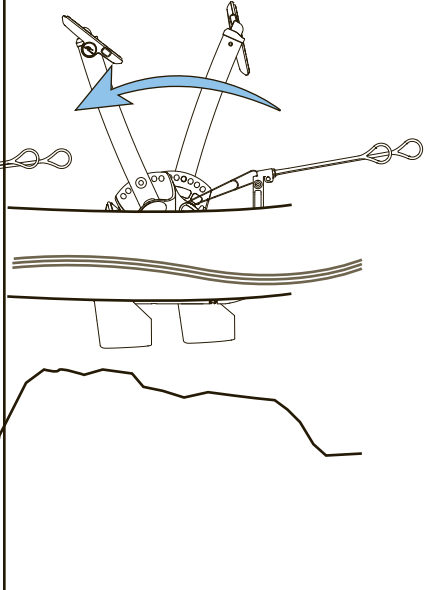

The kick up fins will automatically retract backwards when coming in contact with any object and resume their normal position when clear of obstruction and you pedal.



The 'Rudder' T-Handle is located on the right/ starboard side near the front of the kayak.

### Rudder DOWN

Uncleat 'Rudder' T-Handle to deploy rudder.

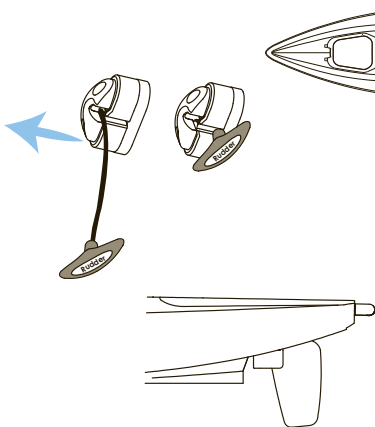

### Rudder UP

Pull 'Rudder' T-Handle line through cleat to retract rudder.

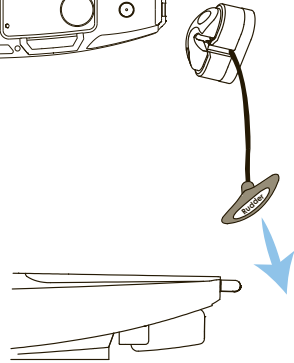

### Steering

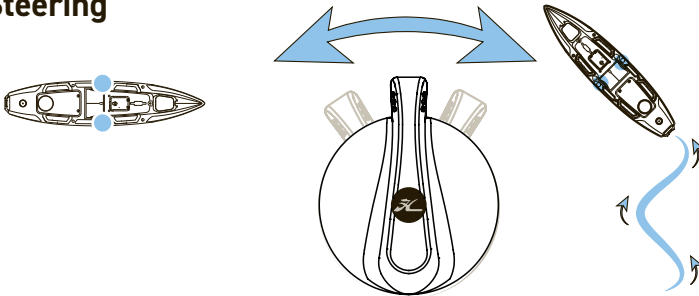

### Paddle Storage

Secure paddle to kayak by hooking the shock cord around eyelet post.

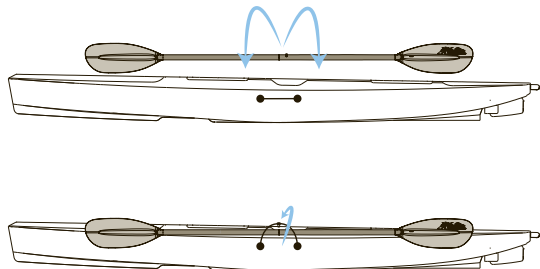

## Transducer Installation

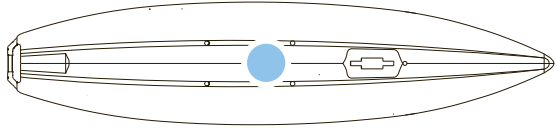

①

Remove the Hobie Guardian shield from hull by unthreading the three screws fastening the shield to the kayak.

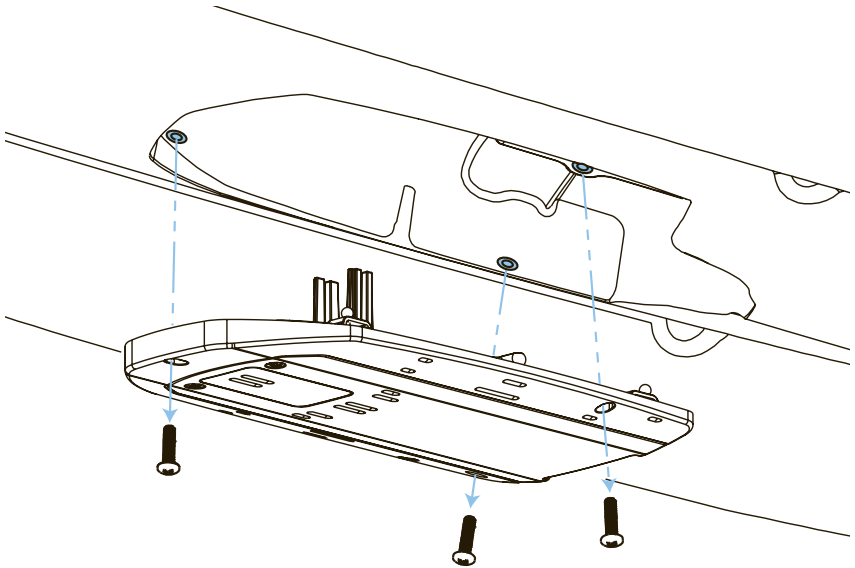

②

For Skimmer style transducer installation, skip forward to page 26. For side imaging transducer installation continue on to the next page.

## Side Imaging Transducer Installation

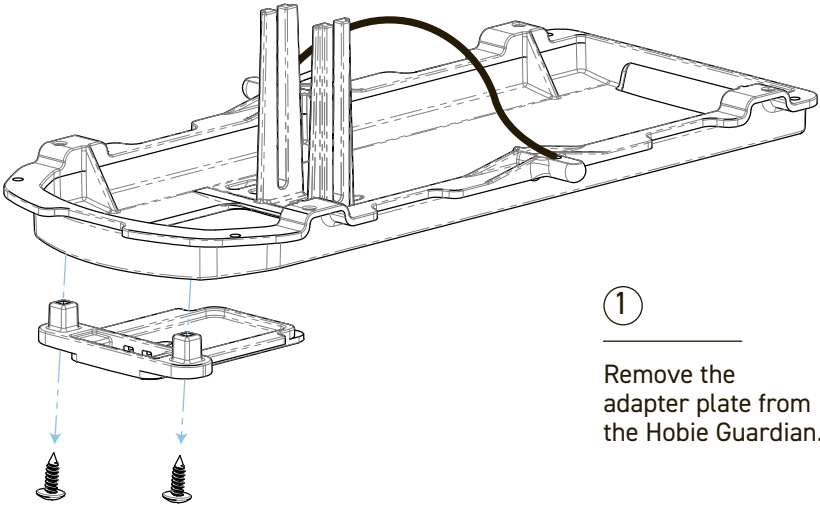

1  
Remove the  
adapter plate from  
the Hobie Guardian.

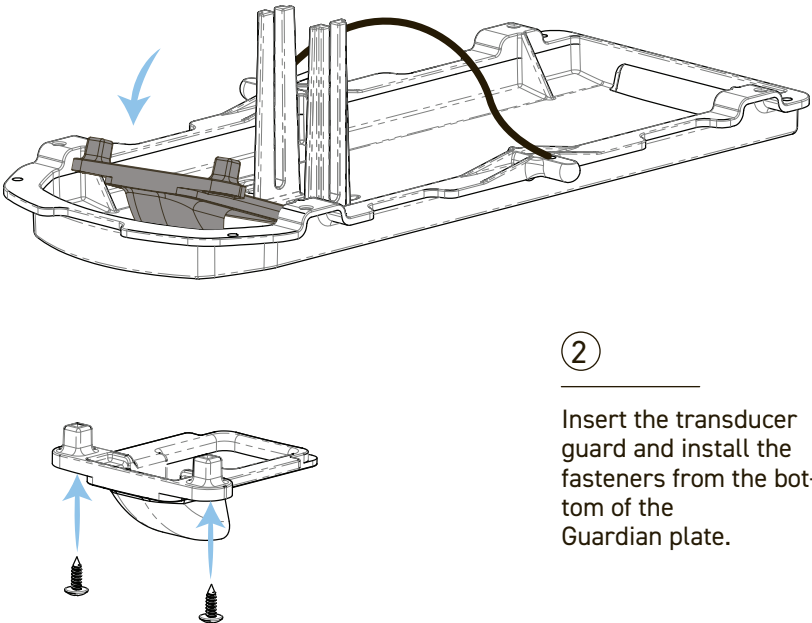

2  
Insert the transducer  
guard and install the  
fasteners from the bot-  
tom of the  
Guardian plate.

③

For most side imaging transducers, we recommend using the mounting bracket included with your fish finder as a drill template for creating mounting holes in the Guardian plate.

④

Some side imaging transducers, like the Lowrance TripleShot, will mount through the bottom of the transducer guard and to the post on the inside of the Guardian plate. For these units, refer to the Skimmer Style Transducer Installation. If the transducer is not sitting flush with the shield, 2 small holes (one on each side of the transducer) can be drilled and a zip tie used to secure the transducer to the shield.

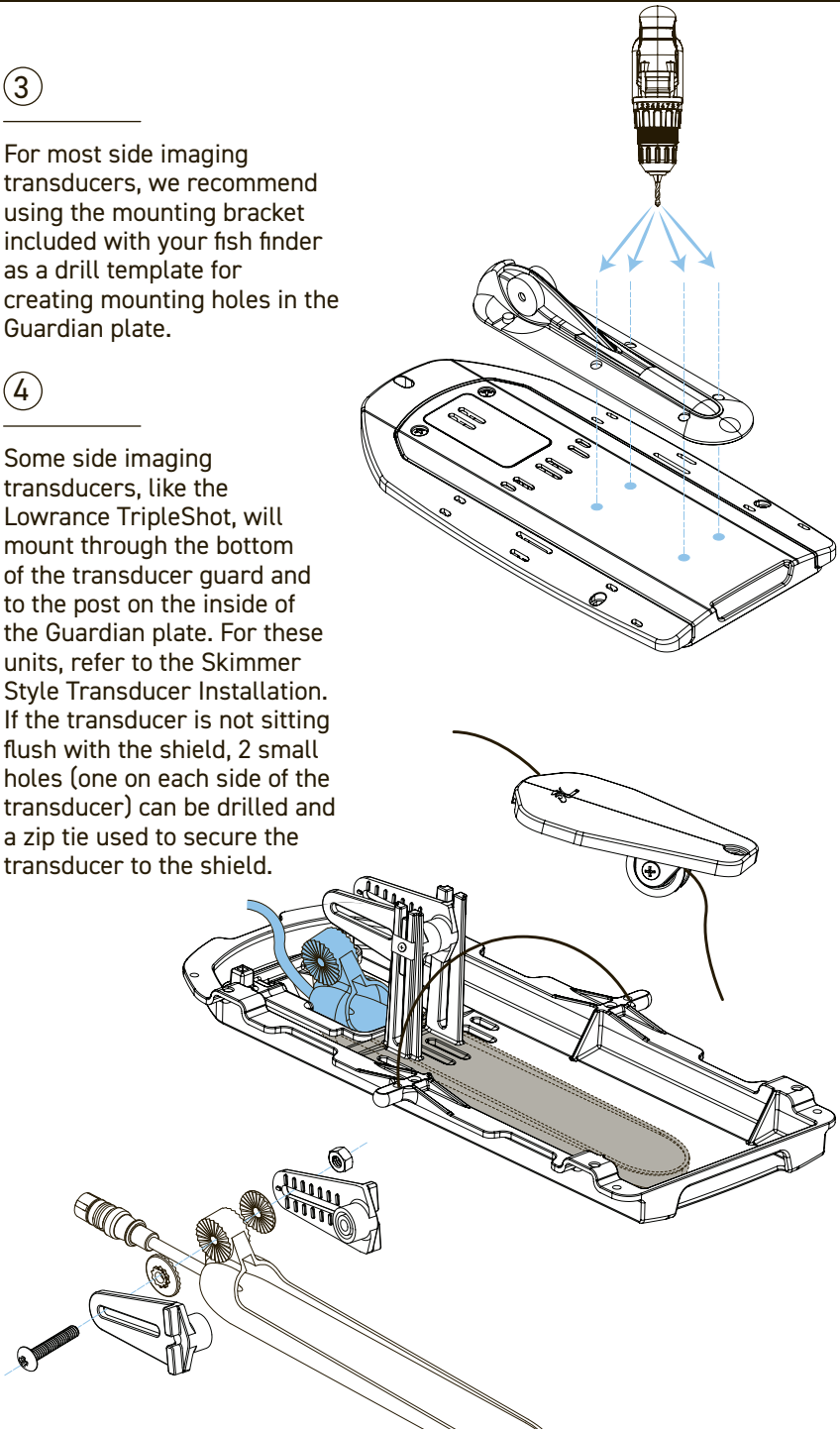

5

After mounting your side imaging transducer to the Guardian plate, you can choose to activate its retraction feature. Remove the screws holding the mounting plate to the Guardian frame.

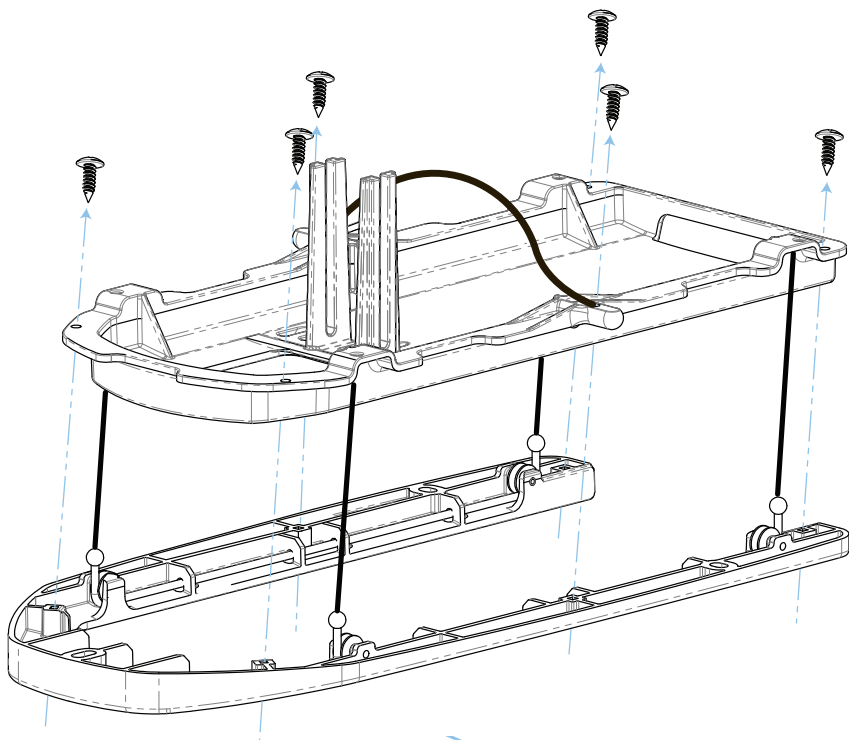

6

Attach the retraction line (tied to the cover plate) to the bridle line for up down control.

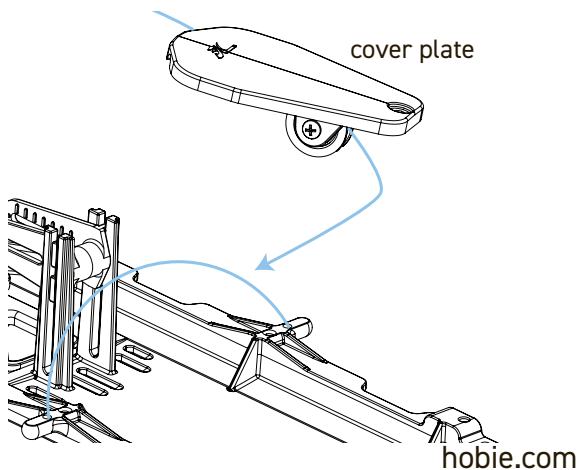

## Skimmer Transducer Installation

①

Skimmer style transducers will mount to the posts inside the transducer cavity using the hardware that comes with the Kayak's Owners Manual.

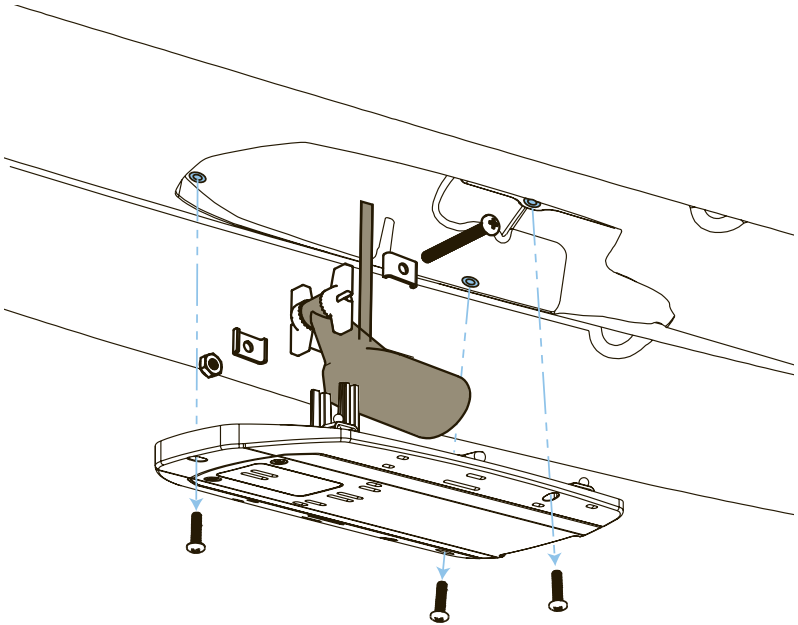

②

Leave a small gap between the bottom of the transducer and shield to allow water flow.

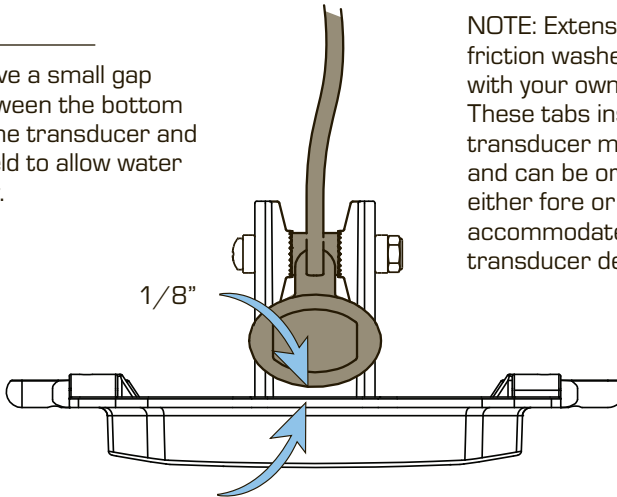

NOTE: Extension tabs and friction washers are included with your owner's manual. These tabs install to the transducer mounting post and can be oriented to face either fore or aft to accommodate a variety of transducer designs.

## Run the Transducer Cable

①

Once the transducer is installed, feed the transducer cable through the scupper hole above the cavity and screw the plate back into place.

You should now have the transducer cable accessible in the cockpit of the kayak.

②

Remove the plug next to the scupper above the transducer cavity using a phillips head screwdriver. Feed the cable through the gasket and into the hull. Find the rubber adapter that matches the diameter of the transducer cable and fit it to the cable. Attach the adapter and cable to the plug and reinstall. Be careful not to overtighten and strip the screws.

TIP: Lubricate the cable with soapy water to allow it to slide through the rubber adapter more easily.

NOTE: Rubber adapters can be found in the kayak owner's manual.

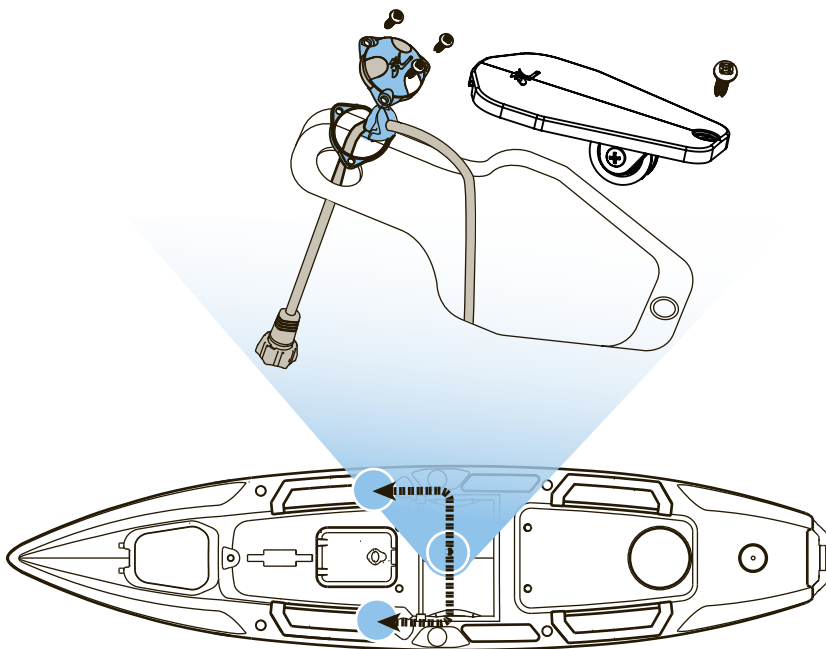

③

Remove the 3-way plug in the cockpit. Lead the cable through the inside of the kayak and exit the cable out through the hole for the 3-way plug in the cockpit.

There are plugs for the wire to exit the hull on either side of the kayak to accommodate a right or left sided screen location. Some plugs are located in cup holder or mesh pockets.

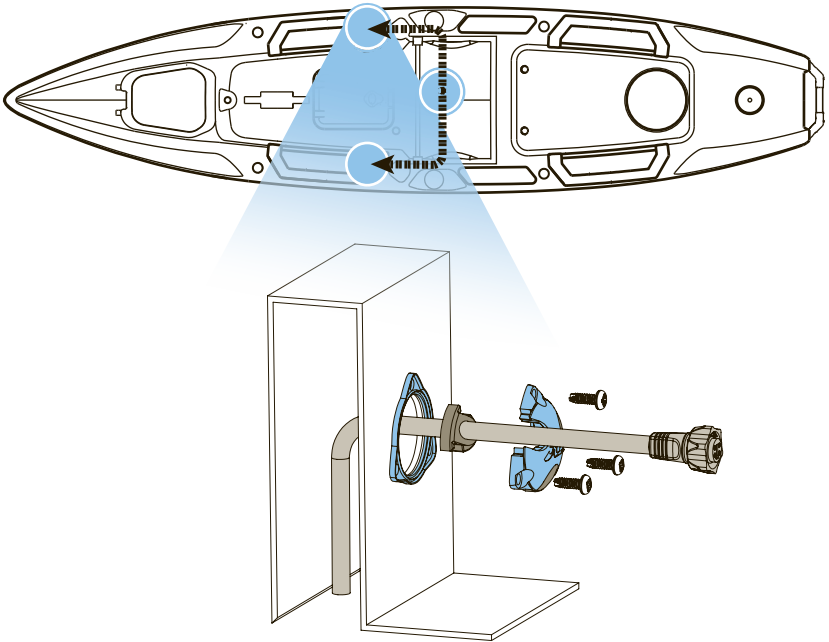

④

Using the same plug, install the power cable.



## Run the Power Cable and Attach the Thru-Hull Plug

1



Run the power cable into the hole for the 3-way plug in the cockpit.

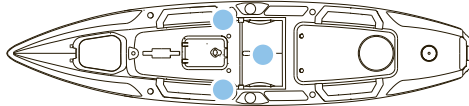

2

Choose the rubber adapter for your wire size and insert the power cable by opening the adapter along the slit.

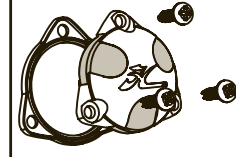
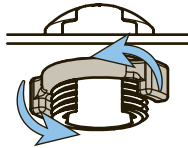

NOTE: Rubber adapters can be found inside the Hobie kayak owner's manual.

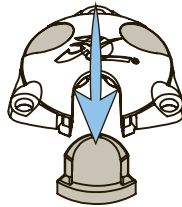
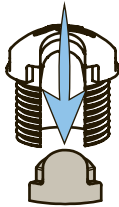

3

Press the rubber adapter with the wire installed into the plastic plug housing, making sure it fits snugly.

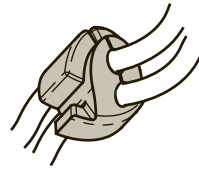
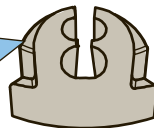
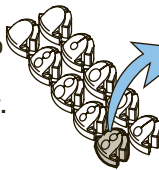

TIP: Lubricate the cable with soapy water to allow it to slide through the rubber plug more easily.

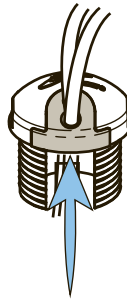
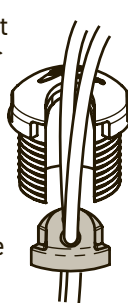

4

Once all the cables are run through the hull, fasten the thru-hull wire assembly to the hull. Hand-tighten the screws on the 3-way plug. Make sure the gasket is properly installed. Take caution to not overtighten the screws.

## Storage Do's

Storing your boat upside down on crossbars or hanging from wide strapping are two ways to keep the boat stored.

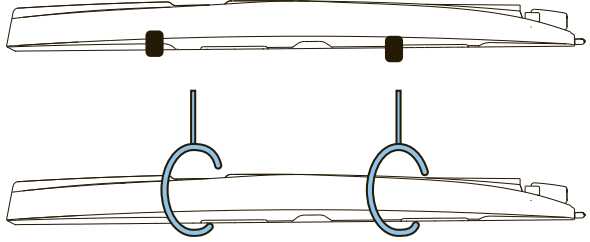

## Storage Don'ts

Storing your boat cockpit side up on crossbars can dent the bottom.

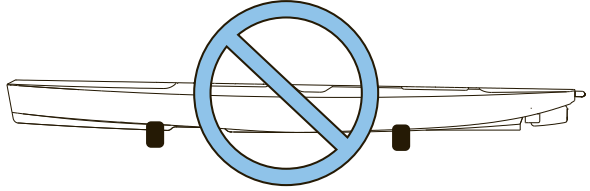

Storing your boat on its side over a long period of time can flatten/dent the sides.

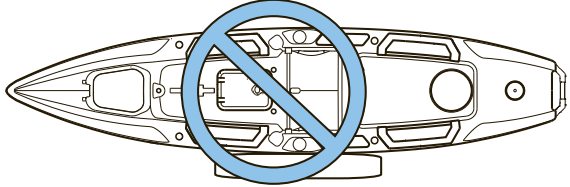

Hanging the boat by the scuppers can distort the scupper holes.

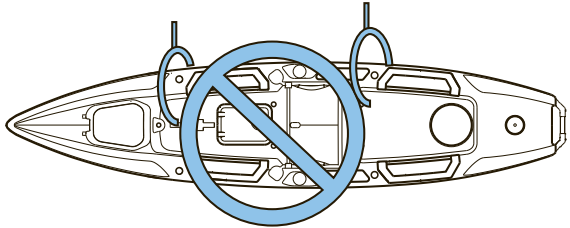

Never hang the boat by handles or pad eyes. They are not designed to handle long-term load and will fail.

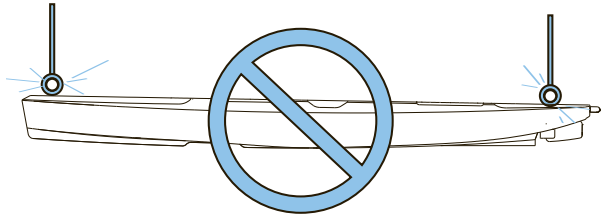

Never use PVC runners or tubes to store boat on.

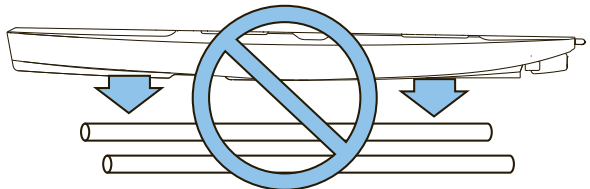

## Additional Storage Key Points

- Always remove all water from boat
- Don't leave tie-down straps tight over a long period of time
- Storing in non-recommended configurations can result in hull damage and can void your warranty

## Cart

The cart should be used for transportation purposes only and not as a storage platform. Do not leave your boat on the cart for more than one hour (less time in warmer temperatures or direct sunlight).

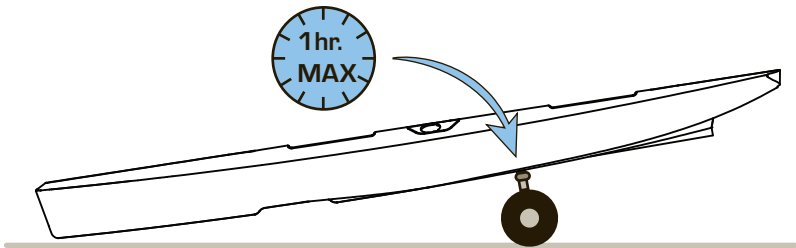

---

## Store out of the Weather

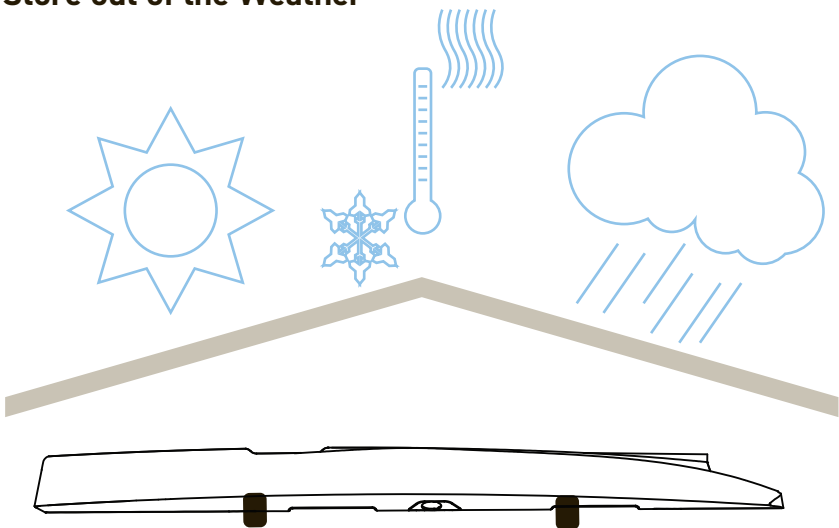

## Roof Topping

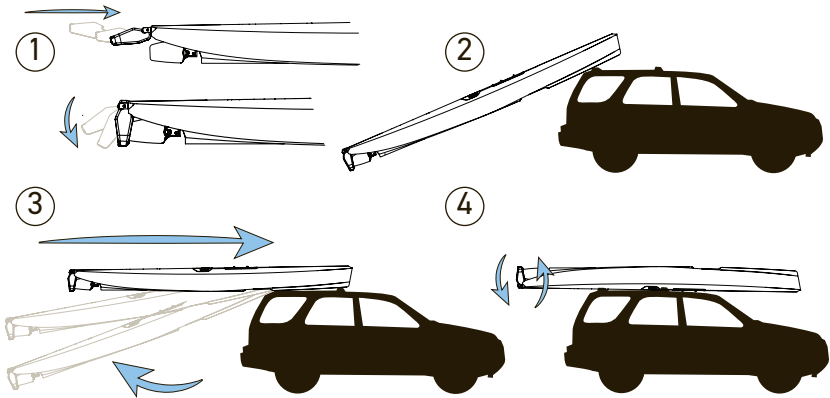

The best way to transport your boat is to purchase a trailer or roof rack from your dealer. The kayak should be transported upside down to reduce the chance of denting the hull. The boat can be transported right side up if the proper after market cradles are used to support the hull. In hot conditions or long term storage, we recommend flipping it upside down to reduce the chance of denting the hull. Straps can then be laid across the boat and tied to the rack bars. Straps should be tight, but not so tight that they distort the shape of the boat. Avoid using ratchet straps to prevent over-tightening.



Be sure to consult your car and roof rack owner's manual to ensure that you comply with all recommendations, precautions and specifications.

Running a line or strap from the bow and stern of the boat to each bumper is required. If your bumpers do not have a gap to pass a rope around, look underneath. There should be a loop of metal, which is used by car transports such as tow trucks.

Many people like to use the scupper holes to tie the boat to the car. This helps prevent the boat from sliding back and forth or the tie-down rope from slipping off the boat. (This is an acceptable method for tying the boat down for transport.)



**NOTE:** Remove the loader when transporting.

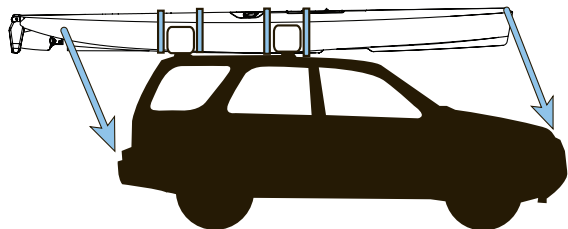

## MirageDrive Regular Maintenance

Note: Excessive sediment on the drive can impair 180 function, rinse thoroughly to avoid this.

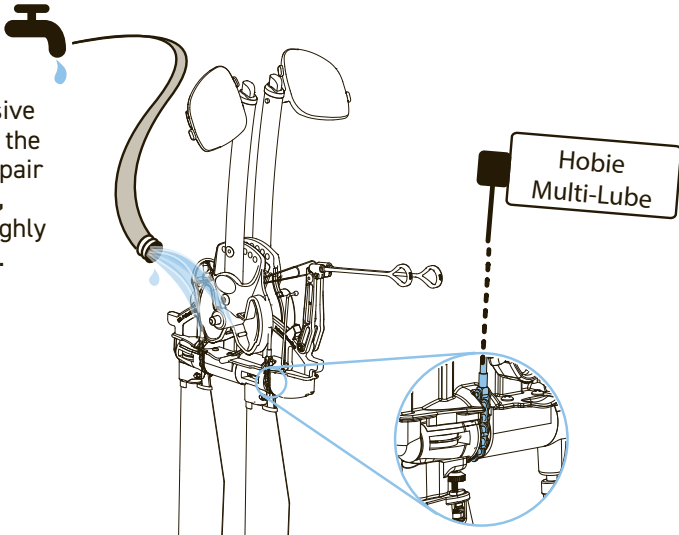

### Checking Cable Tension

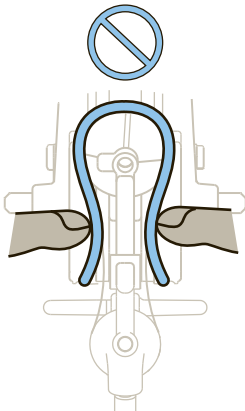
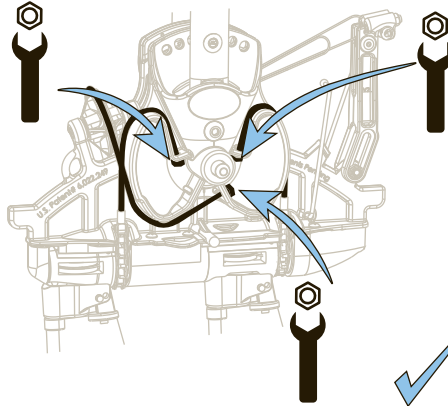

Cables should be tight enough so they can only be slightly squeezed in under firm finger pressure.

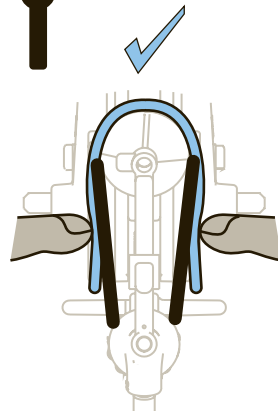

Visit the “support” section at [hobie.com](http://hobie.com) for information on the MirageDrive.

## Rudder Tuning

①

Pull up rudder.

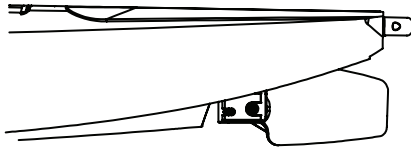

②

Locate screws that clamp the rudder line.

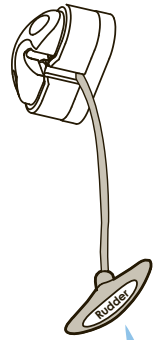

③

Loosen the screw clamping the rudder line.

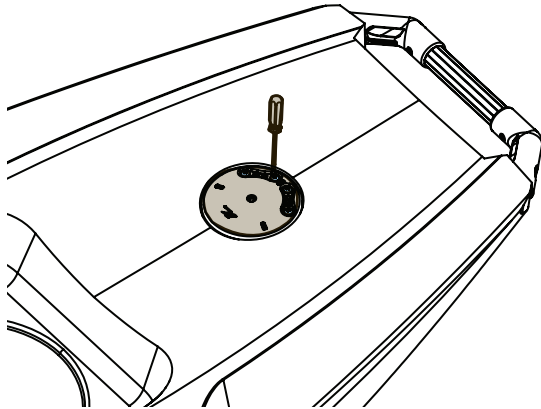

④

Pull the slack out of the rudder line making sure the steering handle is still straight. If it is not straight, adjust the lines accordingly.

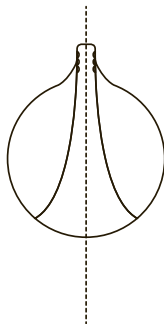

⑤

Tighten the screw to clamp the line and hold it in place.

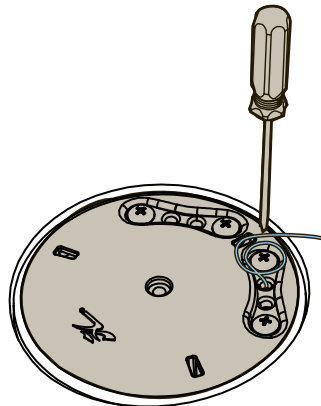

## Checklist

Please read through the owner's information package prior to using this product.

The user of this product acknowledges both an understanding and assumption of risk involved in paddle/pedal sports. Consult your physician prior to beginning.

### Always:

- Wear a Coast Guard approved personal flotation device (lifejacket).
- Dress appropriately for weather conditions; cold water and/or weather can result in hypothermia; apply sunscreen and other sun protective clothing.
- Check your equipment prior to each use for signs of wear or failure.
- Tie a safety leash to your paddle and MirageDrive.
- Scout unfamiliar waters.
- Be aware of river water levels, tidal changes, wind conditions, obstacles in and above the water and weather changes.
- Always make sure that your hatches are secure and closed.
- Carry a pump and/or bailing device.
- Always carry the spare paddle provided with the boat.

### Never:

- Never go alone and always file a float plan.
- Never go in flood and/or fast moving water conditions. Hobie kayaks are not designed for fast moving water.
- Never exceed your ability and be aware of your limitations.
- Never use alcohol or mind-altering drugs prior to or while using this product.
- Never open your hatches in unstable water conditions.
- Never remove the foam pieces inside the hull. They are installed for structure, additional flotation and safety.

## Shakedown Cruise

As with any new product, it is important that you become familiar with the boat and all its features. It is also important to determine that the boat is sound before long trips. We recommend that you do what we call a “shakedown cruise” when the boat is new, after shipping or transport, before long trips and after installing any thru-hull fittings. This test is typically done in shallow, calm conditions where you can familiarize yourself with or test the boat before taking any long trips into open water. Things you should check or practice are:

- MirageDrive installation, adjustment and removal
- Rudder operation
- Closing hatches properly
- Drain plug locations to make sure they are properly installed
- Getting in and out of the boat from a capsized state
- Taking the kayak sail down on the water (if applicable)

## Getting into your Boat

If you fall out of your boat, stay with the boat. You should be properly wearing a life jacket/PFD which will keep you afloat. If the boat is upside-down, it will need to be turned over. To do this, reach across the bottom of the boat and grab the scupper hole or the Hobie MirageDrive and pull the boat upright. Position yourself so your head is near the cockpit area of the boat and you are facing the boat. You will want to be between the seat and the footwell areas of the boat. Reach across the boat to the far edge with one hand. Place the other hand on the near-side rail, then kick with your feet, pulling yourself up and onto the boat. Roll over onto your backside toward the seat, which should place your backside in the seat. Sit up, swing your feet into the footwells and you're ready to go.

## Mirage Kayak Cassette Plug

You Hobie is shipped with a Mirage Cassette Plug. The plug is provided as standard equipment in the Mirage Kayak package. Insert the plug into the Mirage well when the MirageDrive is removed to provide added safety and to “fair” the bottom of the hull when paddling.

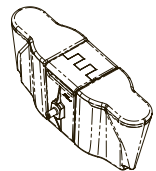

## Kayak Sail Safety

The kayak sail is a very popular optional accessory that works really well with Hobie Mirage kayaks. It is important to familiarize yourself with the use of the sail and how wind power affects the stability of the boat. The sail is not recommended to be used in wind conditions over 10 MPH.



**It is very important that you complete and send us your Warranty Registration Card as soon as possible.**

This information enables Hobie Cat Company to contact you should there be important product information that needs to be shared with you in a timely manner. Please complete the Warranty Registration Card in your Owner's Packet, or take advantage of our online option at:

**<http://www.hobie.com/product-registration>**

or

Scan this QR code with your smart phone



If you have a question or issue with your Hobie product, please see your Authorized Hobie Kayak Dealer. They will assess the problem, assist with a repair and file a warranty claim with Hobie Cat Company if needed. All warranty claims must go through your Authorized Hobie Kayak Dealer. The Warranty Registration Card and Warranty Policies are included with each model in the Owner's Packet. Type in the address below to go to our dealer finder webpage.

All specs, colors, graphics and features are subject to change without notice. Please refer to the website for complete details.

<http://www.hobie.com/dealers>

**Enjoy the Ride!**

For accessories see:  
<http://www.hobie.com/accessories/>

[hobie.com](http://www.hobie.com)







Corporate Headquarters  
Oceanside, CA USA

[www.hobie.com](http://www.hobie.com)