

2 0 1 8

B R U N S W I C K

CENTER
MAINTENANCE
PRODUCTS

T R U S T E D S I N C E 1 8 9 0

Brunswick®

FEATURED PRODUCTS



Brunswick's Envoy lane machine, featuring our innovative Direct+ conditioning system, makes lane maintenance simple and intuitive. The complexity is in the technology, the simplicity is in the operation.

The Phoenix LT4 is easy to operate and maintain. A perfect fit for smaller recreational centers.

ENVOY® LANE MACHINE

See page 14



MAX10 LANE CLEANER

See page 9



PHOENIX® LT4 LANE MACHINE

See page 15



FORMULA 45™ LANE CONDITIONER

See page 6



BLITZ LANE CLEANER

See page 9



PINS

See page 4



PREMIUM RENTAL SHOES

See page 3

GREAT SHOT

Struggling to maintain a consistent, high-scoring lane condition that keeps your bowlers happy? Utilize Brunswick's complimentary "Great Shot" service. For more information visit our website at brunswickbowling.com.

HAPPIER BOWLERS = BIGGER REVENUE

TABLE OF CONTENTS

Bowling Center Supplies

House Balls	2
Ball Carts and Ball Ramp	3
Rental Shoes	3
Pins	4
Lane Monitor System	5
Lane Conditioners	6
Lane Cleaners	9
Lane Cloth and Dusting Supplies	10
Maintenance Supplies	12

Lane Machines

Envoy®	14
Phoenix® LT4	15
Top Moving Lane Machine Parts	16

Resurfacing Products

Lane Finish	18
Finish Applicators	20
Bankshot™ Bumper Bowling	22
Foul Line Decal	22
Guardian®	23
Resurfacing Supplies	23
Replacement Lane Panels	25
Lane Parts	26

Order Forms

House Ball / Rental Shoe / Pins / Ball Carts and Ball Ramp	29
--	----

HOUSE BALLS

ORDER FORMS IN BACK OF CATALOG



MYBALL™ SYSTEM

R8-010059-000 - Fitting Ball and Display Stand

Make selecting a good-fitting house ball easier for your customers with the MyBall System from Brunswick. Our color-coded system and MyFit sizing ball allow customers to easily identify which ball will work best for them, improving bowler satisfaction.

- System includes the MyFit sizing ball with counter display
- Easy identification of hole size and weight. Speeds up the selection process – more time for bowling
- With the MyFit sizing ball, customers select from seven hole drilling sizes (XXS-XXL), then look for their preferred ball weight (6-15 pounds) with the selected hole size

HOUSE BALLS

60-105544-9XX - Undrilled

60-105544-XXX - Drilled

Liven up your center with Brunswick house balls. These bright, glow-in-the-dark bowling balls add color and excitement to any bowling environment. They are a great value and carry a two-year warranty; one year for six pound balls.

- New formulation Brunswick house balls radiate with light for the ultimate glow-in-the-dark bowling experience!
- Urethane balls available in 6 through 15 lbs
- Strong enough to withstand young or unskilled bowlers
- Available in seven drilling sizes as part of the MyBall System



6# - Lime Green Pearl Glow

7# - Fuchsia Pearl Glow

8# - Sky Blue Pearl Glow

9# - Violet Pearl Glow

10# - Orange Pearl Glow

11# - Purple Pearl Glow

12# - Red Pearl Glow

13# - Yellow Pearl Glow

14# - Kelly Green Pearl Glow

15# - Dark Blue Pearl Glow

BILLIARD HOUSE BALLS

60-105507-9XX - Undrilled

60-105507-XXX - Drilled

Brunswick billiards house balls, are ideal for boutiques, clubs, and themed centers. Stripes and Solids match standard billiards set. Weights from 6-15 pounds.



FLASH HOUSE BALLS

60-105986-9XX - Undrilled

60-105986-XXX - Drilled

Light up your center with the new Flash house balls from Brunswick! The Flash house balls are perfect for VIP areas, birthday parties, special events, or for making open bowling more fun and exciting.

- Made of 100% urethane, the Flash house balls feature LED lights embedded into the core of the ball.
- The bright and durable LED lights are initiated by a hard contact with any surface. They FLASH on and off as the ball travels down the lane.
- Available in 8, 10, 12, and 14 pounds. We offer a variety of drilling options that match up with the Brunswick My Ball fitting system.

See them in action! Go to brunswickbowling.com/products/house-balls



8 lb. - Lime Green Pearl



10 lb. - Pearl essence



12 lb. - Orange



14 lb. - Kelly Emerald Green Pearl

BALL CARTS, RAMP, AND RENTAL SHOES

ORDER FORMS IN BACK OF CATALOG



BALL CARTS

62-860311-XXX* - (Two Tier)

62-860312-XXX* - (Three Tier)

These durable and attractive ball carts enable you to easily transport house balls across the center as needed. Available in different colors. See color chart.



COLOR OPTIONS FOR BALL CARTS AND BALL RAMP

Color	Suffix*
Black	000
Silver	004
Green**	001
Yellow**	002
Blue**	003

**Special Order - 8 week lead time



BALL RAMP

62-860310-XXX*

The Ball Ramp enhances the bowling experience for younger bowlers, or those with special needs, making bowling more fun and bringing them back again and again. Available in different colors. See color chart.

REPLACEMENT PARTS

10-751601-000 - Leather Round Slab - Dia. 63.5 x 3

10-751602-000 - Leather Oblong Plate - 130 x 25 x 3

11-616528-000 - Knob - Star Grip - Plastic M8 x 25mm

11-695011-000 - Caster - ø 75mm x 98mm H. Light Duty



PREMIUM RENTAL SHOES

58-109114-XXX - Lace

58-109116-XXX - Hook-N-Loop

If only everything returned its investment as fast and as many times over as Brunswick Premium Rental Shoes. Featuring genuine full-grain leather uppers and soles, foam-padded sock liners, channel stitching, and rubber heels, these shoes are built to last game after game.

- Lace or Hook-n-loop closures
- Glow laces
- Reinforced stitching
- Premium, full-grain leather upper
- Leather sole with channel stitching



HYBRID RENTAL SHOES

58-109305-XXX - Adult Lace

58-109306-XXX - Adult Hook-N-Loop

58-109304-XXX - Youth Hook-N-Loop

- Contemporary look
- Full grain leather soles with recessed stitching
- Double stitched synthetic uppers
- Padded insoles and air grommets
- Lace pairs come with extra laces

YOUTH RENTAL SHOES

58-109115-XXX

- Full-grain leather uppers and lining
- Leather sole with channel stitching
- Hook-n-loop closure
- Eyelets on inside of arch for airflow
- Colors coordinate with Premium rental shoes.



VALUE SPORT SHOES

58-109302-XXX Youth Lace

(Sizes 3.5-7 - EU sizes 24-32
Half sizes beginning at size 1)

58-109303-XXX - Adult Lace

(Sizes Men 4-16, Women 5.5-12.5, EU 36-50)

- Synthetic upper for long life
- Leather sole and rubber heel pad
- Enamel-covered eyelets for added strength
- Eyelets on inside of arch for airflow

PINS

ORDER FORMS IN BACK OF CATALOG



SCORE KING® PINS

- 63-861179-167** - Crowns
- 63-861180-167** - Crowns – Glow Graphics
- 63-861181-167** - Stripes
- 63-861182-167** - Stripes – Glow Graphics

MAX PINS

- 63-861167-167** - Crowns
- 63-861165-167** - Crowns – Glow Graphics
- 63-861168-167** - Stripes
- 63-861166-167** - Stripes – Glow Graphics

SURLYN COATING

All Brunswick pins feature a durable Surlyn® coating. Surlyn is a high-performance resin known for its outstanding resilience and impact toughness. Surlyn is the same cover material used for high-performance quality golf balls.

GLOW-IN-THE-DARK PINS

Our Score King and Max pins feature UV brightener for ultra-white glow under standard lighting; brighter under UV conditions. Pins with glow graphics have an enhanced logo for extra glow under UV conditions.

Brunswick Max and Score King Pins give bowlers the high-scoring action they want and the features you need for maximum durability.

- Multilayer topcoat system keeps pins white and glowing brightly
- Surlyn cover allows for a larger wood core to ensure maximum strength
- Made of the finest northern hard rock maple for maximum durability and pin action
- Score King pins feature a heavy-duty, locked-in black nylon base that looks great. Max pins have a neutral locked-in base that stays in place
- Coated Surlyn cover cleans easily and stays whiter longer
- Score King and Max pins are USBC® approved
- All Brunswick pins are made in the USA
- Choose stripes or crown neck graphics
- Available in sets of ten or individually



MAX COLORED PINS

- 63-861137-167** - Green
- 63-861139-167** - Orange
- 63-861138-167** - Yellow
- 63-861161-167** - Magenta

Let the good times roll with these fun and colorful Max pins. Change out the front pin or the whole set for a new twist on the game. Available in four vibrant, solid colors. Available in single-color sets of ten or individually.



TROPHY PINS

- 63-861157-167** - Sets
- 63-861157-000** - Singles

Perfect for special occasions to help your bowlers remember a significant score or event, our Trophy Pin is made of maple wood covered in a clear topcoat. It can be used as a signature pin for birthday parties or other special events. Available in sets of ten or individually.



HAPPY BIRTHDAY PINS

- 62-861092-167** - Happy Birthday

Help your bowlers celebrate their birthdays with this special-occasion pin featuring the crown graphic as well as a “Happy Birthday” message. The Happy Birthday Pin is a Surlyn-coated maple wood pin that can be used for signatures, too. Available in sets of ten or individually.



UNIVERSAL PIN CLEANER

- 63-860354-005**

Keep pins looking bright and new with this advanced performance cleaner.

- Removes the grime and dirt from pins
- Bgreen product – formulated to be readily biodegradable and environmentally friendly
- Can be used with both hand and machine cleaning systems
- “Universal” because it also makes a great general purpose bowling equipment cleaner

LANE MONITOR SYSTEM

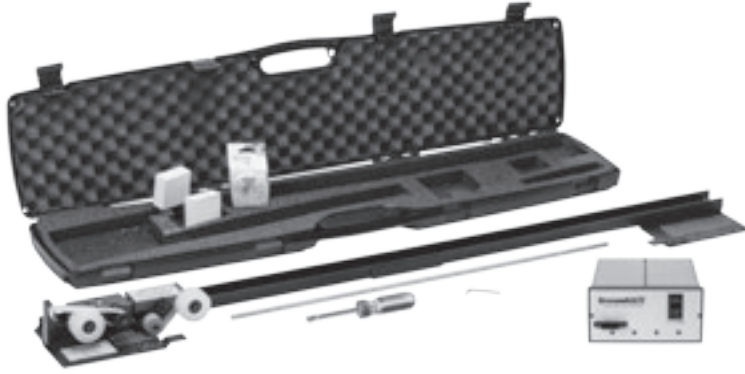

COMPUTER LANE MONITOR SYSTEM™

61-860226-600 - (110 V)

61-860226-620 - (220 V)

Computer Lane Monitor System reduces maintenance time and human error. Includes:

61-100057-000 - (White Label Tape)

11-900070-000 - (UV Pick-Up Tape)

61-860162-000 - (Calibration Kit)

61-860155-000 - (Lane Recorder)

61-860225-600 - (Computer Lane Reader, 110V)

61-860225-620 - (Computer Lane Reader, 220V)

- System includes all components of Computer Lane Monitor Optical Reader, Lane Monitor Recorder, Calibration Kit, UV Pick-Up Tape and White Marking Tape
- Based on the computerized Optical Reader, this system takes the guesswork out of reading tapes and provides immediate, accurate feedback
- Windows® software provides more detailed analysis including 3-D graphics (IBM® compatibility required)
- Measure newly conditioned lanes, as well as changes in lane conditions, such as oil depletion and carry-down
- Keep bowlers satisfied by ensuring that lane conditions are the same from lane to lane and week to week
- Verify lanes are in compliance with USBC® and World Bowling conditioning rules
- The lane monitor system requires use of a lane conditioner containing USBC specified UV additive



LANE MONITOR RECORDER

61-860155-000

The original Lane Monitor Recorder is still the best.

- Two sliding tape carriages in an aluminum track are placed on the lane from gutter to gutter
- One carriage applies the transparent tape to the lane surface to absorb the dressing
- The second carriage lifts the dressing tape and laminates to a second tape, locking the dressing between the two, creating a permanent, accurate sample of the conditioner pattern
- Comes complete with all recorder components, recorder tape, label tape, assembly tool and instructions in a sturdy case

WHITE MARKING TAPE

61-100057-000



UV PICK-UP TAPE

11-900070-000



TAPE HUB

61-100055-003

RUBBER WHEEL ASSEMBLY

61-100055-004

FOOT PAD SMALL

61-100055-016

FOOT PAD LARGE

61-100055-018



COMPUTER LANE MONITOR OPTICAL READER

61-860225-600 - (110 V)

61-860225-620 - (220 V)

An industry standard since 1988, the Brunswick Lane Monitor provides the ultimate in accuracy and reliability for measuring and graphing lane conditioner volume and distribution.

- Higher resolution for improved accuracy
- Increased range accommodates higher conditioner volumes
- Addition of USB port provides compatibility with new PCs
- User-friendly software
- Holds higher graph scales
- High capacity tapes are conveniently read from end to end

COMPUTER LANE MONITOR SOFTWARE

61-860273-400 - CD V1-01

61-860273-401 - CD V2.00



RUBBER ROLLER

61-100261-000



CALIBRATION KIT

61-860162-000

- Package of three strips
- It is recommended to replace calibration strips after one year



UV BULB

61-100060-000

ROLL PIN (1/8" X 1/2")

11-345154-000

LANE CONDITIONERS



FORMULA 45™ LANE CONDITIONER

62-860161-004 - (4 Gallons)

62-860161-001 - (1 Gallon)

Formula 45 uses a special blend of oils with an enhanced additive package to introduce the highest viscosity product to our performance conditioner line. Coupling high viscosity with medium-low lubricity, Formula 45 is the strongest hooking oil in our line. This premium performance conditioner is designed to prolong pattern stability with the desired attributes of durability, consistency, and strong ball reaction. Formula 45 can be used with Brunswick's Direct+ conditioning system and Sanction technology machines. It is not recommended for use with wick or pad machines. This high viscosity product is best suited for synthetic, or low friction lane surfaces, but can be used with any lane surface.

- 100% solids, 45 viscosity
- Top performance on low to medium friction surfaces
- Durable pattern performance
- Easy to remove with Brunswick cleaners
- ThroBot™ tested
- 100% silicone free



DEFYV30™ LANE CONDITIONER

62-860166-004 - (4 Gallons)

62-860166-001 - (1 Gallon)



DEFY™ LANE CONDITIONER

62-860164-004 - (4 Gallons)

62-860164-001 - (1 Gallon)

DEFYV30 adds a higher viscosity version of DEFY into Brunswick's performance conditioner line. Developed with the same specialty blend of top grade oils and unique additives used to create DEFY, both conditioners generate unparalleled performance compared to lane conditioners in the market today. The enhanced flow-back characteristic reduces the impact of ball tracks through the heads while minimizing the movement of conditioner down lane to keep the shot more consistent. These workhorse conditioners offer excellent solutions for high lineage centers to keep your bowlers satisfied, providing predictable, stable ball reactions with bowlers making fewer, less drastic line-up adjustments as the conditions change. Original DEFY is a low viscosity, high lubricity conditioner, new DEFYV30 is a medium viscosity and medium lubricity conditioner, both are compatible with any surface or lane machine. Developed to increase bowler satisfaction, DEFY conditioners are ThroBot™ tested and bowler approved.

- **DEFYV30** (100% solids, 30.0 viscosity)
- **DEFY** (100% solids, 23.0 viscosity)
- Both utilize enhanced flow-back
- Both are durable enough for high lineage
- Both clean easily
- Both are ThroBot approved
- Both are 100% silicone free

LANE CONDITIONERS



LOGIC™ LANE CONDITIONER

62-860162-005 - (5 Gallons)

62-860162-001 - (5 Quart)

Logic Lane Conditioner blends top-grade oils with an enhanced additive package. The result is a low lubricity conditioner with great durability and ball motion on harder, less aggressive surfaces. Brunswick quantified the performance of today's top conditioners through extensive Throbot™ testing. From this data, the best conditioner attributes were used to develop Logic, resulting in the most predictable conditioner on the market to date.

- 100% solids, 43.0 viscosity
- Durable, and resistant to break down
- Consistent performance
- Versatile enough for use on all lane surfaces
- Blended for top performance on low friction surfaces
- Throbot™ approved
- Easily removed with any Brunswick lane cleaner
- 100% silicone free



CONNECT® LANE CONDITIONER

62-860160-005 - (5 Gallons)

62-860160-001 - (1 Gallon)

Brunswick Connect Lane Conditioner combines cutting-edge technology with real-world expectations. Connect uses top-grade oils with an enhanced additive package to produce a conditioner with great durability and ball reaction. Connect lane conditioner allows you to run longer patterns without the risk of losing the outside boards.

- 100% solids, 33.0 viscosity
- Durable pattern performance game after game
- Versatile enough for use on all lane surfaces
- Blended for top performance of medium to low friction surfaces
- Throbot™ approved
- Easily removed with any Brunswick lane cleaner
- 100% silicone free



AUTHORITY22® W22 LANE CONDITIONER

62-860205-005 - (5 Gallons)

62-860205-001 - (1 Gallon)

Authority22 W22's enhanced additive package combined with a special blend of oils creates an easy to use product with reduced carry down that can be easily removed with normal daily cleaning. This premium performance lane conditioner works great on all lane surfaces and can be used with all lane machine technologies.

- 100% solids, 22.0 viscosity
- Pattern friendly, mechanic friendly
- Versatile enough for use on all lane surfaces
- Blended for top performance on medium to high friction surfaces
- Throbot™ approved
- Easily removed with any Brunswick lane cleaner
- 100% silicone free



ABSOLUTE CONTROL® LANE CONDITIONER

62-860143-005 - (5 Gallons)

62-860143-001 - (1 Gallon)

Absolute Control combines the formulas and ingredients from Absolute HV and Control lane conditioners creating a lane conditioner with durability, flexibility and easy cleaning.

- 100% solids, 22.0 viscosity
- Durable pattern performance game after game
- Easily removed with any Brunswick lane cleaner
- 100% Silicone free



CONTROL® LANE CONDITIONER

62-860046-005 - (5 Gallons)

Control lane conditioners offer long-lasting patterns, reduced carry-down and better ball reaction.

- 100% solids, 37.0 viscosity
- Durable pattern performance game after game
- Easily removed with any Brunswick lane cleaner
- 100% Silicone free



COMMAND® LANE CONDITIONER

62-860022-005 - (5 Gallons)

- 100% solids, 22.5 viscosity
- Cleans easily
- 100% Silicone free

LANE CONDITIONERS

LANE CONDITIONERS: COMPARISON OF PHYSICAL CHARACTERISTICS

Conditioner	Viscosity	Surface Tension	% Solids	Specific Gravity	Wicking Time
Brunswick DEFYv30	30.0	26.5	100%	0.875	13:40
Brunswick DEFY	23.0	26.0	100%	0.875	7:30
Brunswick Formula 45	45.0	25.0	100%	0.856	N/A
Brunswick Logic	43.0	25.0	100%	0.876	14:30
Brunswick Connect	33.0	24.5	100%	0.850	13:23
Brunswick Authority22 W22	22.0	24.5	100%	0.853	7:30
Brunswick Absolute Control	22.0	24.0	100%	0.879	7:24
Brunswick Control	37.0	24.5	100%	0.852	13:47
Brunswick Command	22.5	26.1	100%	0.848	7:10

LANE CONDITIONING TIPS

WHAT IF I HAVE TOO MUCH CARRY-DOWN

Decrease the distance of the applied oil in the center of the lane leaving the pattern distance the same. This adjustment increases the buff distance and reduces the oil thickness at the end of the pattern.

WHAT IF I DON'T HAVE ENOUGH HOLD

Hold is created by the length and amount of oil in the "mid-lane" (20-32 ft.). This is done by applying oil in the mid-lane on the reverse pass of most lane machines. Lengthening the reverse application distance creates hold oil which allows the ball to more consistently guide to the breakpoint. With Brunswick's Direct+ Conditioning this can be easily accomplished by adding oil to the required boards in zones that affect the mid lane during the forward run.

WHAT IF MY BACK ENDS ARE TOO STRONG

Lengthen the pattern to "tone" down the ball reaction. Make sure that the conditioner application distance does not change, only the total pattern distance.

WHAT IF THE HEADS HOOK

Two things cause the heads to hook. 1. Not enough oil applied to the head area. 2. The physical condition of the heads. To increase the volume of oil in the heads, slow the machine down on the reverse pass. With Brunswick's Direct+ oil system, during the forward run you can increase the units of oil by board in the head zone(s) to resolve this problem.

WHAT IF I HAVE NO SWING AREA

A lack of swing area can be caused by two things: 1. too much oil applied to the outside boards or 2. "crowned" lane topography. Reduce the amount of oil on the outside boards if there is too much. If topography is the problem, contact your professional lane resurfer.

WHAT IF THE MID-LANE BALL TRACK HOOKS TOO MUCH

The mid-lane ball track can hook if there is not enough oil or if there is too much oil. This can be determined by looking at the pattern settings along with Computer Lane Monitor graphs.

For help with your lane conditions, call 1-800-YES-BOWL, or contact your Brunswick Aftermarket Product Specialist. Contact info at brunswickbowling.com/contact/aftermarket-product-specialists.

LANE CLEANERS



MAX10 LANE CLEANER

62-860239-025 - (2.5 Gallons)

MAX10 Lane Cleaner is a heavy-duty concentrated cleaner designed to work with the modern, faster lane cleaning machines. MAX10 Lane Cleaner is highly effective in removing the newer lane conditioners containing high viscosity synthetic mineral oils and performance additives.

- Great value - 2.5 gallon bottle makes 10% more product than traditional 5 gallon buddy pack of 4:1 cleaner
- Superior lane cleaning performance
- Provides strong and consistent backend reaction
- One pass cleaning on even the toughest conditioners
- Non-hazardous for shipping
- Save on freight and storage space
- Bgreen cleaner
- For vacuum lane cleaning only



BLITZ CONCENTRATED LANE CLEANER

62-860250-000 - (10 - one-pint)

Blitz is an environmental friendly, Bgreen 20:1 concentrated lane cleaner that can be used to remove any lane conditioner in a single pass. Just add water and Blitz is ready to use. Blitz requires no dissolving due to it's liquid homogenous formulation. Save freight with the small package that is easy to handle and reduces storage space.

- Effective cleaning
- Economical and Environmentally friendly
- Increases backend reaction to help pin carry
- Reduced shipping costs because of its higher concentration
- BLITZ comes in a package of 10 one-pint bottles. Each package makes 25 gallons of product, which is comparable to a 5 gallon buddy pack of 4:1 cleaner.



JUDGE® LANE CLEANER

62-860066-005 - (5 Gallons)

Judge lane cleaner is designed to remove difficult to clean lane conditioners. Formulated with an enhanced additive package to produce Brunswick's strongest cleaner yet. The Judge is a non-hazardous cleaner that can be used with all vacuum lane cleaning equipment.

- Water based lane cleaner
- Designed for difficult to clean conditioners
- Premium performance
- Fresh scent
- Bgreen cleaner
- For vacuum lane cleaning only



MAX20 LANE CLEANER

62-860239-000 - (10 - one-pint)

MAX20, a 20:1 concentrated cleaner, incorporates a unique set of properties that make it ideal for cleaning even the toughest conditioners in a single pass. Since MAX20 is a liquid concentrate it does not need to dissolve and is ready to use when combined with water. Max power in a mini package. MAX20 comes in a package of 10 one-pint bottles. Each pint makes 2.5 gallons of product. The package is comparable to a 5 gallon buddy pack of 4:1 cleaner.

- Excellent lane cleaning performance
- Provides a strong and consistent backend reaction
- One pass cleaning on even the toughest conditioners
- Non-hazardous for shipping
- Save on freight and storage space
- Bgreen cleaner
- For vacuum lane cleaning only



AUTHORITY22® LANE CLEANER

62-860206-005 - (5 Gallons)

- Special additive package to clean even the toughest lane conditioners
- Special de-foaming agent for large tanks
- Cleans with one pass
- Bgreen cleaner
- Guaranteed performance



INVINCIBLE® LANE CLEANER

62-860055-005 - (5 Gallons)

62-860055-030 - (30 Gallons)

Designed to clean even the toughest lane conditioners. Formulated to be fast acting for today's newer lane machines. Simply the most effective lane cleaner available today.

- Water based lane cleaner
- Special additive package to clean even the toughest lane conditioners
- Guaranteed performance
- Bgreen cleaner
- For vacuum lane cleaning only



NO-SPILL MIXING VESSEL 14-860209-000

- Patented technology
- Controls liquid flow to cleaner tank
- Convenient no-spill container
- Holds 2.5 Gallons of mixed cleaner

REPLACEMENT SPOUT 14-100355-000

Use as a replacement spout for conditioner container. Not for No-Spill Mixing Vessel.

LANE CLOTH AND DUSTING SUPPLIES



8460QC LANE CLEANING CLOTH

61-860290-000 - (4 Rolls/carton)

8460QC uses the same proven heavy-duty material found in the 8460XL blue cloth but features a quick-change plastic core. This new design will save you time and scrub your lanes clean.

- Saves time
- Easy to use
- Eliminates hassle
- Use with Kegel® wick/pad and pump lane machines 2004 and newer
- 20 yards per roll



8460XL LANE CLEANING CLOTH

61-860250-000 - (4 Rolls/carton)

8460XL virtually "scrubs" cleaning solution onto the lane with its special fiber cloth.

- Heavyweight cleaning cloth
- Use with Kegel wick/pad and pump lane machines pre 2004
- 18 1/3 yards per roll



ENVOY®/AUTHORITY22® DUSTER CLOTH

62-860207-000 - (4 Rolls/carton)

Envoy/Authority22 Duster Cloth cleans the lane before the cleaner is applied. The process uses less cloth and helps the cleaner work directly on the conditioner, not the surface dirt.

- Water-resistant core
- Special fiber maximizes scrubbing action
- Absorbs dirt and cleaner fast
- For use in Brunswick injector lane machines
- 20 yards per roll







GOLD EDGE LANE CLEANING CLOTH

61-860252-000 - (4 Rolls/carton)

Gold Edge Cloth is composed of a special mixture of fibers to maximize "scrubbing action" and edge out the competition.

- Quick-absorbing design for fast and complete cleaner pickup
- Specially designed scrubbing weave
- Use with wick/pad and pump lane machines
- 20 yards per roll

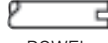
LANE CLOTH AND DUSTER COMPARISON CHART

Lane Machine or Duster Type	Brunswick	AMF	Rolls Core/Dowel	Yards PER Carton	Cloth Per Roll	Overall Width	Width
Kegel Machines 2004 and Newer	61-860290-000	N/A	Plastic	4	20	43"	44-3/4"
Kegel Machines Pre 2004	61-860250-000	294008460	 CORE	4	18-1/3	43"	44-3/4"
Envoy/Authority22	62-860207-000	N/A	 CORE	4	20	43"	44-3/4"
Gold Edge Lane Cleaning Cloth	61-860252-000	N/A	 CORE	4	20	43"	44-3/4"
Brunswick, DBA, Perry-Austen Lane Maid DBA Aluminum Duster DBA Lane Runner	61-860168-000	294008430	 DOWEL 7/8" Diameter	3	33-1/3	43"	44-3/8"
Brunswick Lane Duster All Century Machines PA Champion Century Hot Duster DBA Strip n' Dust DBA Lane Walker DBA Excel	52-860078-000	294008443	 CORE	4	25	43"	44-3/4"

LANE CLOTH AND DUSTING SUPPLIES



RED EDGE® ** LINO-DUSTER CLOTH

61-860168-000 - (3 Rolls per carton)
52-860078-000 - (4 Rolls per carton)

Red Edge Lino-Duster Cloth contains strong, long fibers that trap and hold dirt improving cleaning performance.

- Removes dirt, while leaving conditioner pattern undisturbed
- Available in two sizes to fit many lane dusters
- 100 yards per box

**See Chart on Page 10.



BRUNSWICK LANE MAID 61-860158-001

Brunswick's unique design provides the ideal way to get the dust without disturbing the lane condition.

- Aluminum support bar applies even pressure to foam pad and duster cloth for a complete cleaning, regardless of lane conditions
- Cloth contours to any lane and any lane surface
- Automatic action ratchet advances duster cloth with no fuss
- 43" wide duster cleans the entire lane in one pass
- Lightweight for easy maneuvering
- Installing clean duster cloth is a snap



LANE MAINTENANCE APPLICATOR

61-860230-000 - (Complete applicator)
When cleaning lanes by hand, there's no better tool to use.

- Reinforced handle won't break or bend as you apply pressure
- Grips terry cloth lane towels for heavy-duty lane cleaning
- Replacement Pad (NEW) 61-100272-000

62-860101-000 - Channel Mop Complete

62-860103-000 - Channel Mop Heavy Duty Refill

LANE CLEANING AND DUSTING TIPS

- Check the condition of the cleaning pad or cushion roller
- View the lane machine spray pattern
- Be sure spray jets are not clogged
- Inspect the condition and adjustments of squeegee blade(s)
- Are lanes air-drying or is cleaner being removed by your machine?
- Be sure to dust your lanes daily from pin deck to foul lines, prior to cleaning
- Avoid using hard water to mix your cleaner, as hard water reduces a cleaner's effectiveness
- Test your lanes regularly to verify the effectiveness of your cleaning system.
- Verify cleaner supply tank is full before cleaning lanes



PRECISION GUTTER AND CAPPING MOPS

62-860093-000 - (Set of two mops)

Cut cleaning time in half by using these convenient mops.

- Specially designed mop head cleans cap and gutters at the same time
- One mop has a larger head for ball return caps and gutters, the smaller mop cleans division caps and gutters
- Package comes complete with one mop of each size
- Mop head made from strong woven yarn that grabs dust from caps and gutters
- Heavy-duty reinforced stitching prevents lint-free yarn from coming loose
- Mop heads are machine washable
- Swivel handle for easy operation

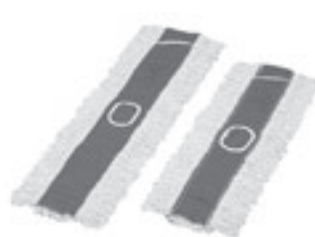

PRECISION GUTTER AND CAPPING MOP REFILLS

62-860094-000 - (Set of two mop heads)

Don't let old, worn mop heads increase work by forcing a need to double run the gutters.

- Replace the old ones with clean, new mop heads
- Same high-quality mop heads as the original
- Heavy-duty reinforced stitching, strong lint-free cotton yarn, and machine washable
- Set comes complete with one larger mop head for ball return caps and gutters and one smaller head for division caps and gutters



APPROACH MOP

62-860095-000 - (Complete mop)

62-860096-000 - (Mop head refill)

Keeping approaches clean is essential for optimum sliding conditions.

- 36" wide mop head is ideal for dusting approaches
- Durable cotton yarn head attracts dust and dirt, leaving approaches clean
- Washable and replaceable

MAINTENANCE SUPPLIES



IPA 99 SYNTHETIC APPROACH CLEANER

61-860254-000 - (12 x 1 Quarts with 4 sprayers)

61-860255-000 - 4 refill bottles (1 Gallon each)

Synthetic approaches require cleaning with a product that won't leave moisture on the approach surface. IPA 99 effectively "conditions" a synthetic approach after it has been spot cleaned; it also displaces surface moisture as part of a regular synthetic approach maintenance program.

- Convenient 1 quart spray bottles with sprayer
- One gallon refill containers
- Pulls moisture from synthetic approaches
- Not recommended for use on wooden approaches



APPROACH DRY SLIDE

62-860210-600 - (12 x 11.2 oz. Canisters)

Approach Dry Slide is a non-abrasive powder used to eliminate sticky approaches. It can be used on both wood and synthetic approaches and is easy to apply. Offered in convenient 11.2 oz. shaker canisters for ease of application.

- Non-abrasive
- Eliminates sticky approaches
- Used on both wood and synthetic approaches
- Best product offered to eliminate sticky approaches



APPROACH SPOT CLEANER

62-860034-004 - (4 x 1 Gallons)

Keep approaches looking clean and spotless.

- Removes dirt and heel marks fast and efficiently
- Solvent-based cleaner dries quickly
- For use on all approach surfaces



APPROACH TREATMENT

62-860078-001 - (4 x 1 Gallons)

Take the stickiness out of approaches.

- Improves slide conditions for sticky approaches
- Provides long-lasting, effective treatment on both wood and synthetic lanes



ARMOR SLIDE

62-860024-000 - (2 Gallons)

Give synthetic approaches better slide characteristics, use Armor Slide.

- General purpose approach aid improves approach performance
- For synthetic approaches only



AEROSOL APPROACH SPOTTER

130190 - (12 x 13.5 oz.. cans)

- Easy to use
- Great for quick spot cleaning



AUTOMATIC PINSETTER CLEANER

62-860083-005 - (5 Gallons)

Here's an effective way to degrease and clean metal pinsetter parts.

- Strong, solvent-based cleaner cuts through tough pinsetter grease and grime
- Note: Do not use on nonmetal parts



BRUNSWICK LIQUID FRICTION PIN DECK TREATMENT

62-860138-000 - (2 x 1 Gallons)

Plus empty pint spray bottle per carton

Effectively ends out-of-range and sliding pin problems. Also quickly and effectively increases the coefficient of friction of pins decks, promoting falling pins over sliding pin action.

- Easy to use. Just spray and dry
- Works effectively on wood or synthetic pin decks



DECK CHUTE CONDITIONER

62-860029-000 - (1 Quart)

Improve the durability and performance of deck chutes. Longer lasting and more stable, this Advanced Performance deck chute conditioner has been designed to minimize deck jams by allowing pins to slide easily through the chutes.

- Improved formula promotes longer chute life
- Durable and more stable
- Minimizes deck jams and downtime

MAINTENANCE SUPPLIES



BRUNSWICK SHOE SPRAY

61-860062-000 - (12 x 15 oz.. cans)

Strike rental shoe odor dead with power to spare.

- Clean, fresh scent to please customers
- Keeps front desk storage area odor free for a pleasant work environment
- One 15 oz. can deodorizes approximately 300 pairs of shoes



TILE-LASTIC WAXLESS FLOOR COATING

1905611 - (4 x 1 Gallons)

- Contains no wax. Easy to apply. Dries quickly
- Needs no buffing or polishing
- Can be used on all types of floors

COSMIC® FOG FLUID

62-860112-004 - (4 x 1 Gallons)

Brunswick Cosmic fog fluid is a water based formulation created to be used as a special effect for open bowling or special events.



COMMAND NETWORK™ TEAM SCORING RECAP FORMS

57-860422-000 - (4-part form/pkg of 750)

- Use this special NCRTM paper in Command Network printers
- Distribute forms to team captains, league secretaries, offices/managers, newspapers, or others who could benefit from the scores



GREY AUTOMATIC PINSETTER PAINT

62-860062-000 - (One 12 oz.. can)

Keep the pinsetter looking as good as new. Fix nicks, scratches and scrapes quickly and easily.

- This is the original grey paint used on the automatic pinsetter
- Convenient spray paint dries quickly to a durable finish
- Available in a 12 oz. aerosol can



FACTORY FINISH BUFFING COMPOUND

14-800009-000 - (2 compound blocks per pkg.)

Utilizes the same ball polish products as our manufacturer. Helps restore your ball to its out of the box look. Factory Finish can be used with plastic, urethane or performance balls.

- Fits Ballworx, LustreKLEEN, and Lustre King ball polishing machines
- Factory finish gloss for all balls
- Replaces Brunswick Lustre Sheen, LustreKLEEN and DBA Blue Genie compounds

LANE MACHINES



ENVOY® LANE MACHINE

R8-040000-001 - Envoy with 30Ahr Lithium Battery and AC/DC Power Supply (115V)

R8-040000-002 - Envoy with 48Ahr Lithium Battery and AC/DC Power Supply (115V)

R8-040000-005 - Envoy with AC/DC Power Supply (115V)

R8-040000-201 - Envoy with 30Ahr Lithium Battery and AC/DC Power Supply (230V)

R8-040000-202 - Envoy with 48Ahr Lithium Battery and AC/DC Power Supply (230V)

R8-040000-205 - Envoy with AC/DC Power Supply (230V)

Since the introduction of the B90 oiling machine in 1962, Brunswick has been a leader and an innovator in automatic lane maintenance systems. And we've learned a lot along the way. The Envoy is a state-of-the-art cordless system centered around your needs.

- Direct+ conditioning, with its direct-to-lane conditioner application, takes away the variation that comes with transfer system machines
- Despite its sophistication, the six-button Graphical User Interface makes the Envoy simple to program and easy to operate
- Envoy's cleaning system, featuring a unique V-shaped squeegee, assures your lanes are thoroughly clean so the shot is consistent
- FlexPower gives you the option of running on AC or two different types of battery power, whatever your center needs
- The Envoy is easy to operate, only requires five minutes of daily maintenance and comes with a two-year warranty

ENVOY FEATURES

DIRECT+ CONDITIONING

When you talk about lane maintenance, you're only as good as your conditioning system – and Envoy delivers industry-leading performance.

With the accuracy competitive bowlers have come to expect, Brunswick's Direct+ system provides individual board-by-board application for superior pattern consistency. That's why it's been used for every PBA Pro Tour tournament since 2006.

Direct+ applies conditioner simultaneously across the entire lane through 39 individually controlled Accu-ject injectors. Direct-to-lane application for each board provides unmatched consistency – no zigzags or multi-component transfer systems to blur the results.

Oil Application

With Direct+ conditioning, you know the right amount of oil is on the lane exactly where you want it, regardless of lane typography. Oil application is computer controlled by varying the injector pulse rate, not the speed of the machine. Machine speed is set to optimize cleaning and minimize time on the lane.

The on-board heater warms conditioner oil to 80°F, ensuring consistent application, while the buffer brush finalizes taper for smoother transitions.

Superior Technology

Leveraging fuel-injector technology from Mercury Marine, Direct+ applies conditioner simultaneously across the entire lane through 39 individually controlled Accu-ject injectors.

GRAPHICAL USER INTERFACE (GUI)

What good are great pattern options if you can't figure out how they work? The Envoy features a Graphical User Interface (GUI), making programming a breeze. Easy-to-read color displays are just as simple to use.

Programming in units – the same measure used by the Computer Lane Monitor to assess pattern compliance – takes away the guesswork so adjustments can be made in seconds. The GUI can be removed for

programming when and where it's convenient. With Direct+ GUI, customizing the patterns that work for your bowlers is a snap.

Convenient and Easy-to-Use

The GUI navigation is controlled by simple six-button keypad below the full color screen and a redundant six-button keypad on the T-handle. The GUI can be removed for programming when and where it's convenient.

The easy-to-read GUI displays battery voltage, charging status and more. It even assists with troubleshooting through an easy diagnostic program. Color graphics display each pattern's programmed zones and oil levels.

Security and Reporting

Multiple levels of security are available to control which machine functions can be accessed and adjusted by different users. Error messages automatically notifies the user when cleaner and conditioner levels are getting low. Automated logs track and record time and user name for major functions including: pattern application, pattern design changes, and maintenance and system messages.

Edit and Manage Patterns

Patterns are defined in "units," removing the guesswork of programming in "loads." The GUI stores 10 active patterns, and another 50 in memory.

Use the Brunswick Crown Pattern Zone to download and use patterns for leagues, tournaments and special events. Use Pattern Manager and Pattern Editor to create or edit your own patterns. Patterns can be adjusted one board – or groups of boards – at a time.

V-SCRUB CLEANING SYSTEM

When it comes to lane performance, cleaning is a big part of the equation. With Envoy, machine speed is selected to optimize cleaning. Its four new cleaner nozzles are 50% larger to resist clogging.

The unique V-shaped squeegee head guides waste for quick, efficient pick-up. Even our absorbent wiper rotates and the squeegee

blades flip to allow for multiple uses and reduced maintenance/operating costs. It's a timesaving design that just makes sense.

FLEX POWER

The Envoy can be quickly switched between battery or AC/DC power supply operation. Equipped with an on board power supply, plugging in the power cord and jumper allows for a seamless transition between these options. The lithium battery uses a smart charger to optimize battery life and performance. The charging cycle and battery use are monitored and logged through the Graphic User Interface. A buzzer will alert you if the machine is not charging after use. If the unexpected happens and the battery was not charged, your machine will be ready to go with the back up power cord.

EZ OPERATION

Unparalleled performance and flexibility make Envoy easy to understand and even easier to use. In fact, a new user can get up to speed in less than 30 minutes. Innovations like our EZ steer technology improve lane positioning and maneuverability with a new large front wheel design.

Envoy can also be pre-programmed to apply different patterns on different sets of lanes for different leagues on different days. And daily maintenance is simple – just refill, clean and wipe down the machine after use. User friendly with no wasted time and effort – that's Envoy.

SAFETY

Remote controlled emergency stop shuts off machine when operating on battery power, protecting the Envoy and pinsetters from damage if the lane is accidentally turned on.

The Envoy comes equipped with an audible alarm, alerting you if the battery power is low or the machine is not properly plugged in when charging. With LEDs that illuminate to verify proper charging, you can rest assured you'll have power for your next cleaning.

BRUNSWICK PATTERN MANAGER SOFTWARE

14-860027-000

Brunswick Pattern Manager is a program developed specifically for Direct+ conditioning technology users. The Brunswick Pattern Manager allows you to easily download patterns from the Brunswick Pattern Zone and transfer them to your Envoy® or Authority22 lane machine.

BRUNSWICK PATTERN EDITOR SOFTWARE

14-860028-000

The Pattern Editor is a plug and play software that allows you to edit and/or create your own patterns. This add on software to the Pattern Manager helps you build your own library of patterns to meet the needs of your bowlers.

PHOENIX® LT4 LANE MACHINE

R8-010061-000 - (110V 60 Hz)

R8-010062-000 - (220-230V 50Hz)

The Phoenix LT4 is an affordable lane machine designed specifically for centers 16 lanes or less. New features have been added to enhance this easy to operate combination machine which cleans, oils and buffs in a single pass. The Phoenix LT4 is an efficient and affordable solution for your small center's lane maintenance needs. Enjoy the simplicity of operating a LT4.

- Clean and condition a 16 lane center without stopping to refill cleaner and conditioner tanks or emptying the waste tank
- Easy to use so that "anyone" can program or operate the Phoenix LT4 with little or no instruction
- New 4 pattern option provides both open and competitive bowling conditions
- Simple and intuitive operation allows for quick training



TOP MOVING LANE MACHINE PARTS

ENVOY®

11-655070-000	Spray Tip - 110 Deg. .05 GPM, S.S.	11-655089-000	Fitting- Male Conn 3/8 Tube	14-100406-000	Assy - Line Strainer, Cleaning System
11-655073-000	Gearbelt- 1/2 Wide x 3/8 Ptch x 28.5" Lg	11-672528-000	Relay - Power, T9A	14-100755-091	Assy, Condition Pump w/ Fittings
11-655078-002	Hose - 1-1/2" x 27" Wire Sppt PVC	11-696006-000	Circuit Breaker - Thermal 25 Amp	14-100758-091	Assembly, 24V Cleaner Pump
11-655086-000	Strainer - 100 Mesh Screen	14-100235-091	Pk-Assy, Cable End Lane Sensor	14-100914-000	Assy - 24VDC Vac Motor With Con Seal

ENVOY OR AUTHORITY22®

11-537051-000	Grip-E Ring .250 Dia - Buffer/Idler	11-655057-000	Fitting 90 Degree Street Elbow 1/8	14-100355-000	Spout - Nozzle/Funnel w/ 38mm Redr Colr
11-600010-000	Master Link 1/4" #25 Assy	11-655063-000	Fitting Male Connct 3/8 Tube x 1/8 NPT	14-100378-000	Foam - Vacuum Diffuser
11-616025-000	Switch-Duster Cloth Up/Dn Lever Type	11-655065-000	Dial-Pressure Gauge, 2 Dia 0-60 PSI	14-100390-000	Foam - Middle Frame Section
11-616026-000	Switch-.1A@125VAC, Buffer/Sq Up/Dwn	11-655084-004	Filter - Screen Only, 100 Mesh	14-100393-000	Assy - Handle Keypad w/ Backer Plate
11-655004-000	Retainer - Tip, Cleaner Spray	14-100030-000	Assy - Mid Guide Wheel (Conical)	14-100427-000	Foam - Buffer Shield Drip
11-655024-000	Assy - Oil Prefilter 40 Mesh w/o Fit	14-100036-000	Assy - Guide Wheel, Mid	14-100430-000	Grommet - Conditioner/Cleaner Tanks
11-655024-004	Prefilter - Oil, Screen Only, Cyl 40 x 30	14-100043-000	Assy - Buffer Brush	14-100437-000	Cap - Conditioner Tank
11-655029-001	Filter - Spin-On Oil, 10 Micron	14-100104-000	Felt - Vacuum Deflector	14-100487-000	Seal - Waste Tank, "D" Shape
11-655040-000	Fitting - Swivel Male Elbow 3/8 x 3/8	14-100106-000	Felt - Vacuum Deflector, Side	14-100521-091	Pk-Assy Absorbent Wiper V-Squeegee
11-655043-006	Tube - 3/8ODX .295IDX 20"Lg A22	14-100138-000	Caster - 3" Swivel	14-100523-091	Pk-Assy Blade, V-Squeegee
11-655044-000	Assy - Filter 200 Mesh w/o Fittings	14-100139-000	Assy Swivel Caster 3" Dual Wheel	14-100531-000	Assy Transition Wheel
11-655044-004	Filter - Screen Only, Cyl. 50 x 250M	14-100141-000	Block - Over Travel Upper A22 L/M	14-100543-000	Assy Over Travel Block
11-655048-000	Fitting - Male Conn 3/8 Tube x 1/4 NP	14-100254-000	Assy - Cable, Speed Sensor	14-100556-091	Assy HP Absorbent Wiper V-Squeegee
11-655052-000	Fitting - Tube 1/4 Od x 3/8 Stem Od	14-100279-000	Assy - Front Wheel Guide (Conical)	14-100557-000	Foam Buffer Shield Drip, High Perfmc
11-655053-000	Fitting - 90 Degree Fixed Elbow	14-100323-000	Injector - Conditioner	14-100580-000	Foam - Conditioner Tank Neck
11-655054-000	Fitting - Male Connector 1/4 x 3/8 NPT	14-100353-000	Assy - Line Strainer, Cleaning System	14-860242-000	Pkg - Fuse, 2A 250V Slow 5mm x 20mm

AUTHORITY22

11-106649-000	Bolt - 3/8-16 x 1/2 OD x 2-1/2" Shd w/Ptch	11-695010-000	Caster - 02" Dual Wheel	14-100349-000	Motor - Gearmotor, Buffer Up/Down
11-616029-115	Switch - Hi-Inrushm 1350 Series 115V	11-696946-000	Wheel - 8" Authority22	14-100363-000	Foam - Buffer Brush Shield
11-616030-115	Circuit Breaker - Thermal 115V	11-696956-000	Sensor Horizontal Level Gentech	14-100424-000	Grommet - Tank Level Sensor
11-655002-000	Check Valve/Strainer-200 Mesh Clean	14-100081-002	Foam Tube - Duster, 1.62 ID x .75 x 43 L	14-100481-000	Assy Conditioner Filter
11-655003-000	Nozzle - 110" Cleaner	14-100086-001	Valve - Solenoid w/ Conn, Brass Oil	14-100498-000	Assy Emergency Stop, Lane Machine
11-655013-010	Tube - 1/4 OD x .170 ID x 20' Lg A22	14-100116-000	Rear Wheel Mount Chassis	14-100550-000	Assy Cleaner Nozzle Body, Lwr Manfld
11-655022-000	Gearbelt - Synchronous, 1/2 W x 3/8 P	14-100126-000	Blade-Squeegee 60 Duro Flat Urethane	14-860208-115	Pkg - Power Cord, Lane Machine 115V
11-655034-000	Hose - 1.25 ID, 24" Lg, Vacuum	14-100157-000	Power Supply - Meanwell SP-500 Series	14-860216-000	Pkg - Fuse, 10A, 250V Slow, 5mm x 20mm
11-655035-000	Cuff - Hose Cuff, Grey Vacuum	14-100275-XXX	Assy - Vacuum Motor w/Connectors	14-860218-000	Pkg - Fuse 6.3A, 250V Slow, 5mm x 20mm
11-655061-000	Union "Y" 1/4 Tube	14-100277-000	Assy - Duster Motor w/Connector	14-860228-XXX	Pkg Cleaner Pump Assy
11-655102-000	Assembly, Y, 1/4" Tube x 3/8" NPT	14-100282-001	Assy - LH Transition/Guide Wheel	14-860229-XXX	Pkg Conditioner Pump Assy
11-685071-000	Fuse - 3.15 Am 250V Slo Blo, 5mm x 20mm	14-100282-002	Assy - RH Transition/Guide Wheel	14-860240-000	Pk 1-A22 Hvy Duty Dual Caster w/Hrdw

TOP MOVING LANE MACHINE PARTS

PHOENIX® LT4

294116126	Spring, Transfer Roller Assy (LT4)	748901031	Fuse 5 x 20 Mm Slo-Bl (LT4)	01-109	Flat Washer #8 (LT4)
294116137	Squeegee (LT4)	951638078	Washer, #10, External Tooth Lock, SS	01-123	Screw, Phillips Fh 10-32 x 5/8 (LT4)
294116141	Agitator Foam Shim (LT4)	01-009	Screw, Panhead, 8-32 x 3/8 (LT4)	01-229	Nut #6-32 Nylon Lock Zinc (LT4)
294116142	Agitator Foam (LT4)	01-021	Screw 10-32 x 1/2 (LT4)	04-093	Dip Stick Seal (LT4)

PHOENIX LT4 AND MODEL B

01080	Pin - Cotter 1/16 x 1/2 Phoenix Lite	294115287	Pump - 220V 50/60 Hz Ce	294115652	Replacement Foam Low Output
04128	Tygothane Tubing (Per Ft)	294115404	Wheel - Drive	294115737	Idle Wheel Assy LH/RH
04443	Support Grip	294115482	Replacement Foam Med Low Output	808533167	Screw, Button Head 8-32 x 1
294002033	Solenoid 3000 Series LH Term 110V	294115484	Replacement Foam Medium Output	02-335	Switch, Handle
294002275	Solenoid - 240V 50Hz Rh 3	294115486	Replacement Foam Strip Mho Beige	04-322	Filter Bowl
294002401	Strainer, Check Valve	294115488	Replacement Foam Strip Ho Beige	A0024	Spring - Roller Guide
294002404	Tip Retainer	294115490	Replacement Foam Strip Sho Beige	A0025	Base - Pl Ny Guide Rlr Wa
294115046	Encoder	294115509	Oil Tank Gasket	A8307	Waste Tank Seal
294115072	Stem Adapter 3/8 MPT x 3/8	294115525	Cleaner Tank-Phoenix Lite Lm	SA0244	Guide - Wheel Assembly
294115073	Union Elbow 3/8 x 3/8	294115614	Caster 2"	SA1182	Assy - Oil Brush Tube

PHOENIX MODEL B

294002406	Spray Nozzle	294115070	Washer, Viton	294115375	CW Fuse 250V 8.0A Fast Blow
294002407	Spray Nozzle - Outside	294115113	Vac Hose Assembly	294115419	Fuse 500 MA
294115029	Cleaner Foam	294115166	Fuse - 4A Subminiature T	294115615	Caster 3"
294115049	Belt - Buffer Brush	294115366	Fuse - 2A Subminiature	294115656	Cleaner Foam (Agitator)
294115057	Lane Caster - Phoenix Lite	294115367	Fuse - 5A Subminiature	294115672	Oil Tank Drip Foam
294115068	Nozzle Tip - Orange	294115373	Fuse - 10A Relay Board Fuse	SA-3012	Duster End Plate Roller
294115069	Nozzle Tip - Green	294115374	Fuse - 6.3A Relay Board Fuse	SV72	Squeegee - VLS, 89, 90

OTHER PARTS

1530001	Transport Caster 3" 1/2" Bore	1538207	Squeegee Brake Motor Assy	1548805	Vacuum Motor Assy 115/120V Kustodian
1530002	L/W Lane To Lane Casters 2"	1538310	Lane Edge Guide Roller	1548817	Check Valve Assembly For Tank Vent
1530207	Spray Tip - Stainless Steel (8003)	1538407	Buffer Brush Assy (3-3/4" Dia)	1548867	In-Line Cleaner Filter
1530217	Connector - Male Body 1/4 Nylon	1538410	Assy, Lane Edge Gd Rol w/Bshng	1549201	Timing Belt For Head Drive
1530218	Tip Retainer Cap Connector	1538838	Cushion Rllr Assy w/Stems-Px Pxs XL	1530202B	Squeegee Blade Blue Ea Lcm and Ar
1530220	Screen Check Valve Polypropylene 10#	1541262	Fuse-Time Delay (.75A Mdl) UL	1530202C	Squeegee Blade, Brown Ea
1530812	Transport Caster Heavy Duty 2"	1541269	Fuse Time Delay (6A Mdl) UL	1532540A	Spring For Wiping Pad (1-3/4")
1531027	Solenoid 110V	1548617	Pattern Smoothing Pad Assy-Standard	1538827T	1-1/4 PVC Elbow For Recovery Tank
1536252	Spray Jet Body	1548641	Buffer Brush Assembly-Std 3-3/4 Dia	1541250A	Emergency Stop Circuit Breaker Assy
1538204	Squeegee Blade Rplmnt - Pr Blue	1548684	Recrvy Tank Repl. Filter For 1548683	1548617V	Velcro Strip 1/2" x 4-3/8"

LANE FINISH



COSMIC ASTROLANE® LF LANE FINISH

62-860020-000 - (Case of 8 kits)

Low-friction top coat that GLOWS! Squeegee over traditional top coat to keep balls going longer in the heads while reducing overreaction on the back ends.

- A two-component, 100% solids type finish
- Apply with Astrolane 100% Solids applicator assembly (14-860111-000) and 100% Solids applicator refills (14-860108-000)
- Counteracts conditioner depletion
- One kit covers 3 heads, 1-1/2 lanes when applied to the lane conditioner pattern distance or 1 lane when applied from foul line to pin deck



ASTROLANE® 100 TOPCOAT

62-860005-000 - (Non-glow)

62-860124-000 - (Glow-in-the-Dark)

Choose the finish that others strive to match.

- Astrolane 100 Topcoat is the industry standard for durability and appearance
- It's so durable that it often lasts a whole season under normal conditions, virtually eliminating the need for midseason recoating
- Nonflammable with low odor
- Sold in cases of eight kits. One kit per lane
- Apply using 100% Solids Applicator (14-860111-000) and 100% Solids Applicator Refills (14-860108-000)
- VOC compliant in all VOC restricted areas



ASTROLANE® 100 BASECOAT

62-860018-000

Team up this premium basecoat with Astrolane 100 Topcoat for the best system in the industry.

- Offers a solid foundation for Astrolane or other finish systems
- May be used with a variety of lane finish topcoats
- Excellent adhesion characteristics provide superior durability and long life
- Features a special lightening agent to enhance the natural beauty of pine and maple
- Gives old lanes the lighter, cleaner look of new wood
- Nonflammable with low odor
- Sold in cases of eight units. One kit per lane
- Apply using 100% Solids Applicator (14-860111-000) and 100% Solids Applicator Refills (14-860108-000)
- VOC compliant in all VOC restricted areas



COSMIC ASTROLANE® E-Z TOPCOAT

62-860119-000 - (One 1.7 Gallon kit)

All the same durable characteristics as Astrolane E-Z Topcoat, plus UV additive to make lanes glow under ultraviolet lighting.

- Lanes appear normal under white lights
- Applied with the Astrolane E-Z Plus Applicator (61-860241-000) and Long Nap Applicator Refill (61-860242-000)
- Can be used to recoat a variety of compatible topcoats
- VOC compliant in all VOC-restricted areas
- Each kit coats five lanes



ASTROLANE® E-Z TOPCOAT

62-860088-001 - (One 1.7 Gallon kit)

Easy-to-use topcoat combines the strength and durability of 100% solids technology with the ease of conventional lane finish application.

- Extremely durable urethane finish with the same beautiful appearance as Astrolane 100 Topcoat
- A favorite of top-notch resurficers
- Apply with Astrolane E-Z Plus Applicator (61-860241-000) and Long Nap Applicator Refill (61-860242-000) or with Slide-In Applicator (61-860183-000) and Mohair Applicator Refill (61-860185-000)
- Can be used to recoat a variety of compatible lane finish topcoats
- VOC compliant in all VOC-restricted areas
- Each kit coats five lanes



ASTROLANE® E-Z BASECOAT

62-860100-000 - (One 1.7 Gallon kit)

Outstanding adhesion and a durable basecoat with conventional application.

- Two-component urethane system
- Applied with Astrolane 100 E-Z Plus Applicator (61-860241-000) and Foamback Applicator Refill (61-860243-000)
- Works well with any water-based moisture-cure, urethane, or E-Z Topcoat
- VOC compliant in all VOC-restricted areas
- Each kit coats five lanes

LANE FINISH



BRUNSWICK UNI-FLEX BASECOAT

62-860153-005 - (5 Gallons)

Produces unmatched adhesion with the safety and convenience of a water-based finish.

- This durable water-based basecoat is easy to apply with the Slide-In Applicator (61-860183-000) and Water-Based Finish Slide-In Applicator Refills (61-860184-000) or with the Astro E-Z Plus Applicator (61-860241-000) and Foamback Applicator Refill (61-860243-000)
- Dries quickly. Often in less than an hour
- Offers a high degree of flexibility to expand and contract with the lane, greatly reducing cracking, chipping, bruising, and feathering
- Recommended for new or uninjected lanes
- Nonflammable and virtually odorless
- Use in a three-coat system with two coats of Brunswick Hydrolane Topcoat
- VOC compliant in all restricted areas
- Includes additive and whitener
- Each container coats up to seven lanes



ASTROLANE® WB APPROACH FINISH

62-860019-000 - (Four 1 Gallon containers)

62-860019-001 - (1 Gallon)

This great looking approach finish is a favorite of industry professionals.

- Highly durable approach finish rarely needs midseason recoating
- One-coat application dries in one to three hours
- Clean up with soap and water
- Provides uniform slide characteristics
- Resistant to toe and ball marking
- Apply using Approach Applicator (61-860110-000) and Approach Applicator Refill (61-860110-005)
- VOC compliant in all restricted areas
- Each gallon coats up to six approaches



BRUNSWICK HYDROLANE™ TOPCOAT

62-860200-005 - (5 Gallons)

Get an unbeatable combination of exceptional durability and consistently high-scoring characteristics.

- Textured surface holds conditioner in place to help minimize changing lane conditions as bowling progresses
- Extremely durable water-based finish provides a full season of service in most lineage situations, virtually eliminating the need for midseason recoating
- Low odor and nonflammable to help minimize shut-down time
- Easy to apply. Dries completely in four to six hours
- Use over Astrolane 100 Basecoat, E-Z Basecoat or Brunswick Uni-Flex Basecoat
- Apply using Slide-In Applicator (61-860183-000) and Water-Based Finish Slide-In Applicator Refills (61-860184-000) or with the Astro E-Z Plus Applicator (61-860241-000) and Foamback Applicator Refills (61-860243-000)
- VOC compliant in all restricted areas
- Includes additive
- Each container coats up to seven lanes

HYDROLANE CATALYST

62-860202-000 - (12 x 13 oz.)

Included with Hydrolane Topcoat.

HYDROGLOW ADDITIVE

62-860500-000 - (1 x 14 oz.)

The perfect glow-in-the-dark additive for water-based topcoat finishes.

- One 14 oz. additive per five gallons of Hydrolane water-based topcoat provides excellent glowing lanes when exposed to UV lighting
- Not for use with water-based approach finish

UNI-FLEX WHITE ADDITIVE

62-860301-000 - (3 oz. bottle)

Included with Uni-Flex Basecoat.

UNI-FLEX CATALYST

62-860201-000 - (12 x 13 oz.)

Included with Uni-Flex Basecoat.



U-300 SINGLE PACKAGE ULTRAVIOLET FINISH

62-860172-005 - (5 Gallons)

This moisture-cure urethane topcoat looks completely clear under standard lighting, and emits a blue-white aura under ultraviolet conditions.

- Hard, durable finish that requiring no additional clear topcoat
- Each container coats up to seven lanes
- May not be permitted in your area due to local VOC restrictions; check your local VOC regulations or contact your Brunswick distributor for details



U-300 ULTRA HIGH SOLIDS UV TOPCOAT

62-860195-005 - (5 Gallons)

Same great benefits as U-300 Ultra High Solids Topcoat with the addition of an ultraviolet pigment for superior glow under black lights.

- Each container coats up to eight lanes

FINISH APPLICATORS



UNIVERSAL LANE FINISH APPLICATOR
61-860188-000

This economical applicator is designed for conventional application of water-based, moisture-cured urethane and Astrolane E-Z lane finishes.

- Designed to give the user the best view of the finish “puddle” to eliminate mistakes
- Slide-in applicator is easy to assemble
- Includes three sizes of adjustable weights to control film thickness
- Designed for use with Slide-In Applicator Refills
- Not designed for use with 100% Solids coatings



ASTRO E-Z PLUS APPLICATOR
61-860241-000

Designed for conventional application of most bowling lane finishes and a must for application of E-Z Basecoat and Topcoat.

- Ideal for application of water-based urethane and moisture-cure urethane, Astrolane E-Z Basecoat and Astrolane E-Z Topcoat
- Application is simplified. No need to carry a heavily weighted applicator from lane to lane
- Not designed for use with 100% solids coatings
- Use with specially designed adhesive-backed Astro E-Z Plus Applicator Refills



100% SOLIDS APPLICATOR
14-860111-000

This unique applicator is specially designed for applying 100% solids lane finishes and Astrolane Lane Sealer.

- Unique design ensures smooth, good looking finish application
- Includes 100% Solids Applicator Refills (14-860108-000)
- Non-marking wheels make it easy to push down lane
- Quick-release handle for easy coating of pin decks
- Adjustable ears prevent finish from spilling into the gutters
- Comes complete with weights so film thickness can be controlled

WATER BASE APPROACH FINISH APPLICATOR
62-862120-000

- For use with WB approach finish
- Use with refill 61-860110-005

APPLICATOR REFILL AND APPLICATOR CHART

Part Number	Description	Applicator
61-860247-000	Regular Nap, Adhesive Refill (box of 6) - NEW!	61-860188-000 and 61-860241-000
61-860243-000	Wide, Foam backed, Adhesive Refill (box of 6)	61-860188-000 and 61-860241-000
61-860244-000	Terry Cloth, Adhesive Refill (box of 6)	61-860188-000 and 61-860241-000
14-860108-000	100% Solids Applicator Refills (box of 2)	14-860111-000
61-860184-000	WB Finish Slide-In Refills (box of 6)	61-860188-000
61-860385-000	Regular Nap, Slide-In Refills (box of 5) - NEW!	61-860188-000
61-860110-005	WB Approach Applicator Refill (box of 6)	62-862120-000

FINISH APPLICATORS



100% SOLIDS APPLICATOR REFILLS 14-860108-000

For a perfect finish application, start by replacing worn or damaged applicator refills.

- Cushioned refill ensures that a smooth contour is applied to all lane surfaces and lane imperfections
- Durable urethane material cannot be damaged by lane finish, so long life is assured
- Refill conforms to exact Brunswick tolerances to assure a consistent and even finish film thickness
- Refill includes ears and foam cushions
- Keep a few in stock to always be prepared
- Two refills per package

FOAMBACK APPLICATOR REFILLS 61-860243-000

- For use with all water-based lane finishes
- Package of six



MOHAIR SLIDE-IN APPLICATOR REFILLS 61-860185-000 (DISCONTINUED)

This applicator board makes Astrolane E-Z Topcoat and moisture-cure urethane topcoat finish jobs look fantastic.

- Assures a proper amount of finish is applied while eliminating waste and saving money
- Finish flow is consistent, from edge board to edge board
- For use with Astrolane E-Z Topcoat and moisture-cure urethane topcoats
- Installs easily in Slide-In Applicator
- Use with Slide-In Applicator (61-860183-000)
- Package of five

LONG NAP APPLICATOR REFILLS 61-860242-000 (DISCONTINUED)

- For use with moisture-cure urethane topcoats and Astrolane E-Z Topcoat and E-Z Basecoat
- These adhesive-backed refills ensure quick fastening and removal from the E-Z Plus Applicator Long Nap Applicator Refill
- Package of five



WATER-BASED FINISH SLIDE-IN APPLICATOR REFILLS 61-860184-000

Perfect for applying water-based finishes.

- Synthetic foam-flocked material ensures that the proper amount of finish is applied every time, eliminating waste and saving money
- Finish flow is consistent across the lane, assuring complete coverage of edge boards
- Use with Slide-In Applicator (61-860183-000)
- Package of six



APPROACH APPLICATOR REFILL 61-860110-005

This 18" foam-flocked applicator refill is ideal for applying Astrolane WB Approach Finish (62-860019-000).

- Cleans easily with water

WB Lane WB Approach 100% Solids E-Z Base E-Z Top Moisture Cure HS Moisture Cure Grain Stain Lane Sealer

WB Lane	WB Approach	100% Solids	E-Z Base	E-Z Top	Moisture Cure	HS Moisture Cure	Grain Stain	Lane Sealer
			X		X	X		
X								
							X	
		X						X
X								
			X		X	X		
	X							

BANKSHOT BUMPER BOWLING AND FOUL LINE DECAL

BANKSHOT™ BUMPER BOWLING SYSTEM (1 LANE KITS)

171801GK - Medium Gray

171801K - Charcoal

171801MBK - Matte Black

The affordable bumper bowling system that will bring in the bucks, from bumper leagues to bumper birthday parties.

- Easy to install
- Pays for itself fast, turning revenues to pure profits
- Made with all-metal uprights for improved durability and performance
- Goes from up-and-ready to out-of-sight quickly and easily
- Can be automated or integrated with SYNCTM, Vector® and Frameworx® scoring at any time
- Bankshot colors complement any décor

BANKSHOT CHANNEL ONLY KITS

171805K - Charcoal Channel Only Kit

171805GK - Medium Gray Channel Only Kit

171805MBK - Matte Black Channel Only Kit

BANKSHOT RAIL UPGRADE KITS

171806K - Charcoal Rail Upgrade Kit

171807K - Medium Gray Rail Upgrade Kit

171806MBK - Matte Black Rail Upgrade Kit

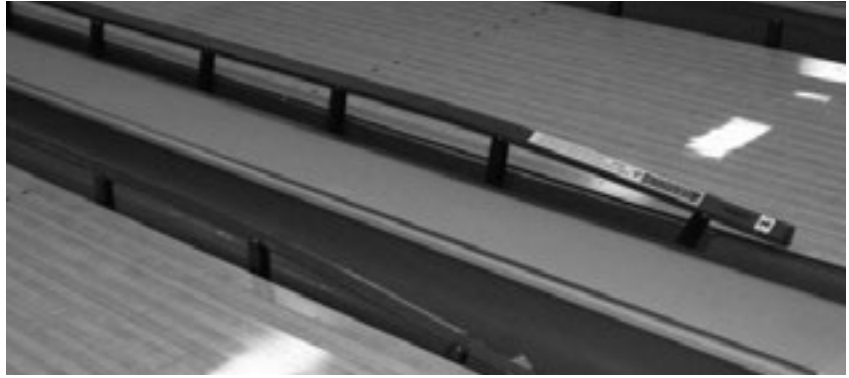

BANKSHOT UPGRADE KITS

84-860703-000 - Gas Spring and Hardware – Single Lane Kit

84-860715-000 - Gas Spring and Hardware – Two Lane Kit

11-210005-000 - Gas Spring only

84-860716-000 - Drill Package for Gas Spring Upgrade

84-860100-000 - Tool Package Improved deployment tool for raising Bankshot

84-860719-000 - Vertical Supports (28 Pk) Includes Washers and Rubber Bushings

84-860720-000 - Vertical Supports (60 Pk) Does NOT include hardware

L2-600074-000 - Short Vertical Upgrade

This new half size support reduces possible damage to the head rail from ball impact. Upgrade package includes 4 short vertical supports with connecting pins.

84-200472-000 - Tool E-Clip Specialty tool for E-clip installation

Part Number	Replacement Rail Sections
84-200478-XXX	LH Pinsetter End Rail
84-200479-XXX	RH Pinsetter End Rail
84-200451-XXX	Common Rail
84-200452-XXX	LH Foul Rail
84-200453-XXX	RH Foul Rail

Part Number	Replacement Rail/Gutter Sections
84-860160-XXX	Pkg-Rail/Gutter Sect LH Foul
84-860161-XXX	Pkg-Rail/Gutter Sect RH Foul
84-860162-XXX	Pkg-Rail/Gutr Sect LH Common
84-860163-XXX	Pkg-Rail/Gutr Sect RH Common
84-860164-XXX	Pkg-Rail/Gutr LH Pinset End
84-860165-XXX	Pkg-Rail/Gutr RH Pinset End

Part Number	Replacement Gutter Covers
84-860622-XXX	Gutter Cover Pkg 118"
84-200465-XXX	Gutter Cover 31.125"

COLOR OPTIONS FOR REPLACEMENT RAIL AND GUTTER

Color	Suffix*
Matte Black	405
Dark Grey	100
Medium Grey	142

Part Number	Replacement Miscellaneous
84-200457-000	Coupler - Rail
84-200463-002	LH Rail Plug Pkg
84-200463-001	RH Rail Plug Pkg
84-200458-001	Pin - Connecting, Upper Arm
84-200458-003	Pin - Connecting, Rail Joint
84-200487-000	Rubber Bushing - Vertical Support
11-537050-000	Retaining Ring
84-200458-004	Pin - Connecting
84-200462-000	Gutter Coupler
84-200459-000	Pin-Connecting, 1.940" Lg
11-537050-000	Retaining Ring
84-200488-000	Decal - Hand Warning
11-682561-000	Label - Warning For Bankshot

FOUL LINE DECAL (PKG OF 6)

84-860266-000 - English

84-860269-000 - Spanish

Help keep your bowlers behind the foul line with this Foul Line Decal. This USBC approved decal is easy and quick to install using the step by step instructions that are included in the package. Made with Guardian, the decal provides great glow under black lights.



GUARDIAN AND RESURFACING SUPPLIES

GUARDIAN®

84-860517-000 - (124' Glow-in-the-Dark)

Extend the life of wood lanes and gain control of the entire lane maintenance program.

- Add years to the life of lanes
- Covers from edge to edge
- Minimizes ball damage to lanes
- Reduces need to recoat or resurface



POWDERED OIL VAC™ LANE OIL REMOVER 62-860074-000

Do the job right. Properly treat the bare wood before applying the basecoat finish.

Contains a powerful absorbent material for drawing conditioner out of wood.

- Improves adhesion of basecoat finish to wood surface while returning wood to original, natural color
- Specially formulated powder is fast-acting and odorless
- Easy to apply and clean up
- Multiple applications may be required for heavily oil soaked lanes
- One 50 lb. bag covers six to eight heads



ASTROLANE® SEALER

62-860130-000 - (1 Gallon kit)

This fast-drying, pre-base coat stain and sealer coat gives older, oil-soaked wood lanes a lighter appearance and allows the base coat to protect the lane.

- Two component, 100% Solids type formulation
- VOC Compliant
- Prevents base coat from soaking into wood
- Results in a smoother, higher-gloss lane finish system
- Apply with Astrolane 100% Solids applicator assembly (14-860111-000) and 100% Solids applicator refills (14-860108-000)
- One gallon kit covers 8 lanes



INJECTION EPOXY

61-860712-000

(White Compound A - 5 Gallon Container)

61-860713-000

(Brown Hardener B - 5 Gallon Container)

More lanes have been injected with this injection compound than all other epoxies combined. With an original process, epoxy is injected into the tongue and groove of lanes, completely filling the areas between the boards, bonding the boards together.

- Eliminates feathering; greatly reduces wood damage due to board movement
- Lanes will last longer. Resurfacing won't require sanding off as much wood
- Use two parts Compound A with one part Hardener B
- (Was Perry Austen 2D30030599 - A and 2D30040599 - B)



SHIELD URETHANE COATING

62-860063-001 - (Gallon)

A routine coat of Shield urethane decreases wood damage and increases pin deck life.

- Use on wood pin decks, flat gutters and kickbacks
- Easy-to-apply clear urethane coating dries to a smooth, durable finish
- One gallon covers approximately 300 to 500 square feet
- Note: Brunswick Shield contains volatile organic compounds (VOCs). Before using, check local regulations for VOC restrictions



BRUNSWICK INJECTA-PATCH LANE EPOXY

61-860256-000 - (3 oz. cartridge*)

61-860257-000 - (static mix tube for 3 oz. cartridge*)

61-860258-000 - (3 oz. cartridge trigger dispenser)

61-860259-000 - (14 oz. cartridge*)

61-860260-000 - (static mix tube for 14 oz. cartridge*)

61-860261-000 - (14 oz. cartridge Heavy Duty trigger dispenser)

61-860262-000 - (3 oz. plunger for older trigger dispensers)

This epoxy formulation is designed to look more like wood and to sand like wood. The heavy duty, 14 oz. cartridge trigger dispenser has the power to inject epoxy into lanes; more convenient than injection machines for injection repair or lane injection of a few lanes.

- Fast curing
- Sands like wood
- * Sold individually

RESURFACING SUPPLIES



PERMA GRIP PAD HOLDER

61-860097-000

Ensure that the synthetic pads stay firmly in place when cleaning, polishing, or conditioning lanes and floors.

- Features 1/2"-long tufts of untrimmed polypropylene widely spaced on the face of the disc
- The individual filament brushes penetrate the synthetic pad and hold it in place
- Allows operator to heel lane machine without recentering the pad
- This holder is designed so that larger polishing pads can also be used
- **WARNING:** Do not use brush or pad with flammable materials (fuels, solvents, thinners, etc.). Serious injury could result from fire or explosion

ROTARY BUFFER SCREENS

61-860034-002 - 80 Grit, 18" Square, Each

61-860034-003 - 180 Grit, 18" Square, Each

61-860034-008 - 220 Grit, Silicon Carbide, 5pk

61-860034-007 - 320 Grit, Silicon Carbide, 5pk



CLEANING DURA PADS (BLACK)

61-860023-000 - (Package of 10 - Black)

These pads are designed to handle the toughest floor cleaning jobs.

- Excellent for heavy-duty cleaning
- Thin, black pads are constructed from durable, nylon web
- 19" pads fit most floor buffing machines

CAUTION: Test before using. May abrade some surfaces.



19" COTTON BUFFING BONNET PAD

62-860193-000

The 19" cotton buffing bonnet pad can be used with rotary floor machines to buff and polish approaches. For optimal absorption the buffing bonnet should be washed prior to use.



SCRUBBING DURA PADS

61-860027-000 - (Pkg of 10-Thin, Green) - 20"

61-860117-000 - (Pkg of 5 - Thick, Tan) - 19"

Keep pads in stock to ensure a well maintained center.

- Pads are made from durable, woven nylon fibers
- Excellent for applying conditioner, polishing, and light cleaning duties
- Use with all rotary floor machines
- Wash and reuse
- Available in two thicknesses
- Pads fit most floor buffing machines



TREATED PAPER

61-860032-000 (Sheet)

Capture excess finish while protecting covered surface from damage.

- Specially treated paper prevents finishes from soaking through to the area beneath it
- Reduces cleanup time by collecting excess finish
- Not just for resurfacing work
- Sheet dimensions are 45" x 48"

TACK CLOTH

61-860026-250 (250 yard roll)

Eliminate all dust and grit that can interfere with the perfect coating job.

- This sticky cloth attracts and holds particles to produce an extremely clean surface
- Leaves lanes perfectly clean
- Use after screening to pick up dust and particles
- A "must-use" for a professional-looking finish

REPLACEMENT LANE PANELS

7/16" Anvilane™ Lane Panels (special order only)

84-200261-000 - 7/16" Maple Laminate Plate Finish
84-200262-000 - 7/16" Foul Line Laminate Plate Finish
84-200263-000 - 7/16" Pine Plate Finish Panel
84-200265-000 - 7/16" Approach Plate Finish Panel
84-200266-000 - 7/16" Division Plate Finish Panel
84-200267-000 - 7/16" Return Plate Finish Panel
84-200272-000 - 7/16" Head Plate Finish Panel

GID 7/16" Anvilane Lane Panels (special order only)

84-200261-900 - GID 7/16" Maple Laminate Plate Finish
84-200262-900 - GID 7/16" Foul Line Laminate Plate Finish
84-200263-900 - GID 7/16" Pine Plate Finish Panel
84-200265-900 - GID 7/16" Approach Plate Finish Panel
84-200266-999 - GID 7/16" Division Plate Finish Panel
84-200267-999 - GID 7/16" Return Plate Finish Panel
84-200272-900 - GID 7/16" Head Plate Finish Panel

3/8" Anvilane Lane Only Lane Panels (special order only)

84-200718-000 - 3/8" Lane Only LH Foul Line Panel
84-200719-000 - 3/8" Lane Only RH Foul Line Panel
84-200720-000 - 3/8" Lane Only LH Arrow Panel
84-200721-000 - 3/8" Lane Only RH Arrow Panel

GID 3/8" Anvilane Lane Only Lane Panels (special order only)

84-200718-999 - GID 3/8" Lane Only LH Foul Line Panel
84-200719-999 - GID 3/8" Lane Only RH Foul Line Panel
84-200720-999 - GID 3/8" Lane Only LH Arrow Panel
84-200721-999 - GID 3/8" Lane Only RH Arrow Panel

3/8" Non Textured Anvilane Lane Panels (special order only - 89" T-panel)

84-200614-000 - 3/8" LH Approach Panel
84-200615-000 - 3/8" RH Approach Panel
84-200616-000 - 3/8" LH Foul Line Panel
84-200617-000 - 3/8" RH Foul Line Panel
84-200618-000 - 3/8" LH Arrow Lane Panel
84-200619-000 - 3/8" RH Arrow Lane Panel

GID 3/8" Non Textured Anvilane Lane Panels (special order only - 89" t-panel)

84-200614-999 - GID 3/8" LH Approach Panel
84-200615-999 - GID 3/8" RH Approach Panel
84-200616-999 - GID 3/8" LH Foul Line Panel
84-200617-999 - GID 3/8" RH Foul Line Panel
84-200618-999 - GID 3/8" LH Arrow Lane Panel
84-200619-999 - GID 3/8" RH Arrow Lane Panel

3/8" Non Textured Anvilane Lane Panels (special order only - 85.5" t-panel)

84-200663-000 - 3/8" LH Approach Panel
84-200664-000 - 3/8" RH Approach Panel
84-200666-000 - 3/8" RH Foul Line Panel
84-200665-000 - 3/8" LH Foul Line Panel

GID 3/8" Non Textured Anvilane Lane Panels (special order only - 85.5" t-panel)

84-200663-999 - GID 3/8" LH Approach Panel
84-200664-999 - GID 3/8" RH Approach Panel
84-200665-999 - GID 3/8" LH Foul Line Panel
84-200666-999 - GID 3/8" RH Foul Line Panel

Lane Panels Anvilane Non Text 3/8" (special order only)

84-200661-000 - 3/8" Narrow Ball Return Fill Panel
84-200722-000 - 3/8" Walkway Fill Panel

GID Lane Panels Anvilane Non Text GID 3/8" (special order only)

84-200661-999 - GID 3/8" Narrow Ball Return Fill Panel
84-200722-999 - GID 3/8" Walkway Fill Panel

Lane Panels Anvilane Textured 3/8" (special order only)

84-200705-000 - 3/8" Textured LH Common Panel
84-200706-000 - 3/8" Textured RH Common Panel
84-200707-000 - 3/8" Textured LH Arrow Panel
84-200708-000 - 3/8" Textured RH Arrow Panel
84-200709-000 - 3/8" Textured LH Short Panel
84-200710-000 - 3/8" Textured RH Short Panel
84-200711-000 - 3/8" Textured LH Approach Panel
84-200712-000 - 3/8" Textured RH Approach Panel
84-200713-000 - 3/8" Textured LH Foul Line
84-200714-000 - 3/8" Textured RH Foul Line
84-200715-000 - 3/8" Textured Mo Ball Return
84-200716-000 - 3/8" Textured Narrow Ball Return Fill
84-200717-000 - 3/8" Textured Walkway Fill

GID Lane Panels Anvilane Textured 3/8" (special order only)

84-200705-999 - GID 3/8" Textured LH Common Panel
84-200706-999 - GID 3/8" Textured RH Common Panel
84-200707-999 - GID 3/8" Textured LH Arrow Panel
84-200708-999 - GID 3/8" Textured RH Arrow Panel
84-200709-999 - GID 3/8" Textured LH Short Panel
84-200710-999 - GID 3/8" Textured RH Short Panel
84-200711-999 - GID 3/8" Textured LH Approach Panel
84-200712-999 - GID 3/8" Textured RH Approach Panel
84-200713-999 - GID 3/8" Textured LH Foul Line
84-200714-999 - GID 3/8" Textured RH Foul Line
84-200715-999 - GID 3/8" Textured Mo Ball Return
84-200716-999 - GID 3/8" Textured Narrow Ball Return Fill
84-200717-999 - GID 3/8" Textured Walkway Fill

GID Lane Panels Pro Lane™ (special order only)

84-200436-999 - GID Pro Lane RH Approach Panel
84-200437-999 - GID Pro Lane LH Approach Panel
84-200438-999 - GID Pro Lane RH Foul Line Panel
84-200439-999 - GID Pro Lane LH Foul Line Panel
84-200440-999 - GID Pro Lane Ball Return Fill Panel
84-200445-999 - GID Pro Lane Wide Ball Return Fill Panel
84-200446-999 - GID Pro Lane Walkway Fill Panel

GID Lane Panels Pro Lane Textured (special order only)

84-200696-999 - GID Textured Pro Lane RH Approach Panel
84-200697-999 - GID Textured Pro Lane LH Approach Panel
84-200698-999 - GID Textured Pro Lane RH Foul Line Panel
84-200699-999 - GID Textured Pro Lane LH Foul Line Panel
84-200701-999 - GID Textured Pro Lane Ball Return Fill Panel
84-200702-999 - GID Textured Pro Lane Wide Ball Return Fill Panel
84-200704-999 - GID Textured Pro Lane Walkway Fill Panel
84-200692-999 - GID Pro Lane Head Lane Panel
84-200693-999 - GID Pro Lane Lane Panel
84-200694-999 - GID Pro Lane With Characters
84-200695-999 - GID Pro Lane Short Lane

GID Lane Panels Pro Lane Lane Only (special order only)

84-200700-999 - GID Pro Lane Lane Only Foul Line

LANE PARTS



MAPLE PATCHING STOCK

21-042538-000 - (1 3/32" x 3/4" x LF)

21-033042-000 - (1 9/64" x 3/4" x LF)

Used for repairing unsightly or broken boards in the approach, head or pin deck area.

- Highest-grade clear, select hardrock maple for maximum durability
- Kiln dried for dimensional stability
- Precision-milled for uniformity



PINE PATCHING STOCK

21-033043-000 - (1 9/64" x 3/4" x LF)

Used to repair heavily dented or broken boards in the pine section of the lane.

- Highest-grade select southern yellow pine
- Kiln dried for dimensional stability
- Precision-milled for uniformity

URETHANE FOUL LINE

84-200365-000

MAPLE FACE BOARDS

52-100291-000 - (5-1/2")

52-100473-000 - (6-1/2")



RED FIBER DOWEL

52-200059-000 - (1/2" x 3/4")

52-200060-000 - (11/16" x 3/4")

Used to replace thin or worn lane marking guides.



PINE DOWEL

52-100211-000 - (11/16" x 2")



MAPLE DOWEL

52-100203-000 - (1/2" x 2")

52-100204-000 - (11/16" x 2")

Used to cover holes when face-screwing a wooden head approach or pin deck.



FIBER BED SPOT

21-016034-000 - (1/2")

High-quality material used to replace thin or broken bed spots.

- Conforms to USBC® specifications for bed spot diameter
- Tough, impact-resistant material for maximum durability

LANE PLUGS

84-860600-999 - Nylon Lane Plug GID (500 Pk)

84-860601-999 - Nylon Lane Plug GID (50 Pk)

84-860600-000 - Nylon Lane Plug (500 Pk)

84-860601-000 - Nylon Lane Plug (50 Pk)

- Replacement plugs for Pro Lane™ or 3/8" Anvilane™ phenolic lane panels

PLYWOOD SPLINE ONE-PIECE TAILPLANK

84-200046-000

- Replaces worn tailplank on pin deck with durable plywood version

MAPLE EPOXY KIT

61-860073-999 - (GID)

61-860073-000 - (Non-Glow)

DOW CORNING 795 SILICONE

84-200430-000 - Sandstone

84-200172-000 - Clear

PRO LANE PANEL SEALER

84-860565-000

LANE PARTS

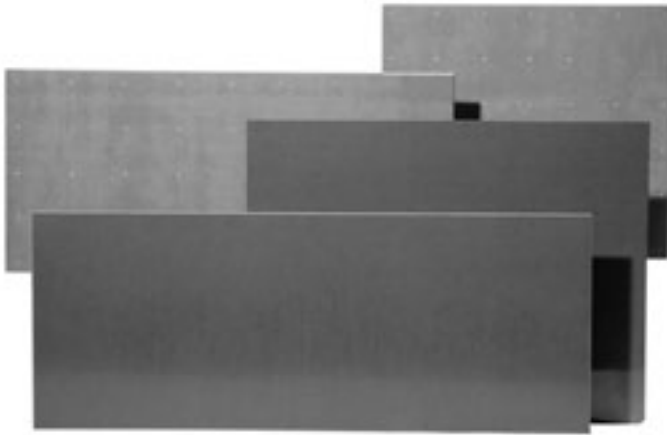

KICKBACK PLATE

52-200005-002 - (R.H. 7-pin side 16" x 40" front plate for GS-Series or armor frame)

52-200005-004 - (L.H. 10-pin side 16" x 40" front plate for GS-Series or armor frame)

52-200005-003 - (29" x 22" rear plate for GS-Series)

21-088674-000 - (21-3/4" x 19" rear plate)

21-088675-000 - (33" x 15" front wood kickback plate)

This solid, active kickback plate will provide improved pin action and more consistent scoring than old, dead plates.

- When kickback plates become soft or loose, they absorb energy from pins, reducing pin action and affecting bowlers' scores
- Durable, impact-resistant plate is made from a solid piece of phenolic material protecting wood kickback from damage over time
- Flexible material won't delaminate or splinter
- All sharp edges are removed to prevent damage to ball and pins
- Surface is non-marking to pins
- Sanded back surface ensures secure mounting. For strongest bond, use Brunswick Adhesive (11-676047-000)
- Pre-drilled



HDPE KICKBACK PLATES

179855 - HDPE Kickback Plate for AMF 15" x 33" (each)

179858 - HDPE Kickback Plate for Brunswick 19" x 23-3/4" (each)

179855P - HDPE Kickback Plate for AMF 15" x 33" (pre-drilled, each)

179856P - HDPE Kickback Plate for AMF 15" x 50" (pre-drilled, each)

179857P - HDPE Kickback Plate for Brunswick 16" x 40" (pre-drilled, each)

179858P - HDPE Kickback Plate for Brunswick 19" x 23-3/4" (pre-drilled, each)

179859 - Kickback Nails, 1", heat-treated twist nails (pound)

- Increases scoring
- Made of high-density polyethylene material. Never needs coating
- Single-piece construction prevents delamination
- Available pre-drilled



BRUNSWICK HDPE FLAT GUTTER

84-860557-000

- Made from extremely durable high-density polyethylene material
- Quick and easy installation
- Lower maintenance costs. No coating is required
- 52" length can be cut to fit all lane configurations

80107B - Flat Gutter (bottom only)

80108L - Flat Gutter (left-hand side)

80108R - Flat Gutter (right-hand side)



BRUNSWICK HEAVY DUTY FLAT GUTTERS

84-860504-000 - (2 flat gutters per package)

Brunswick's best flat gutter. Virtually indestructible, made of Ultra High Molecular Weight polypropylene.

- Bottom of gutter is 1" thick with 3/4" sides
- Dark brown material won't mar pins or balls
- Easy to clean and maintain
- Sold as two flat gutters for one lane
- USBC Approved

52-100472-001 - HD Gutter (bottom)

52-100472-002 - HD Gutter (RH side)

52-100472-003 - HD Gutter (LH side)

LANE PARTS

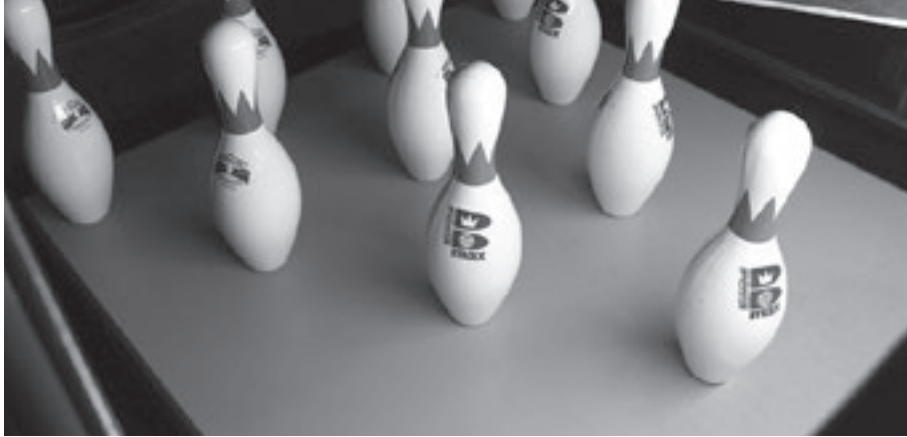

BRUNSWICK ANTI-SKID PIN DECK

418001K - Anti-Skid Synthetic Pin Deck (each/includes adjustable hardware)

418002K - Anti-Skid Pin Deck (top screwed)

418526L - Phenolic Edgeboard (7 Pin Side)

418526R - Phenolic Edgeboard (10 Pin Side)

- Reduces sliding pins
- High-impact surface
- High-density core construction
- Adjustable hardware for replacement installations



SIDE PIN DECK EDGE MOLDING

52-100243-001 - (48" x 2-1/16" for old-style phenolic pin decks/synthetic lanes)

52-100078-000 - (48" x 2-3/4" for old-style phenolic pin decks/wood lanes)

84-200084-010 - (48" x 1-3/8" for integral pin deck/synthetic lanes)

HDPE PIN DECK EDGE BOARDS

179860 - Pin Deck Edge Boards (each)

- Replacement edge boards for wood decks
- Made from extremely durable high-density polyethylene material
- Stronger than wood
- 1" x 2-1/2" x 46"

HDPE TAIL PLANK COVER STRIPS

179861 - Tail Plank Cover Strip (each)

- Replaces entire worn upper sections on tail planks of wood pin decks
- Made from extremely durable high-density polyethylene material
- 1" x 1-3/4" x 43"

HDPE TAIL PLANK END STRIPS

179862 - Tail Plank End Strips (each)

- Replaces worn phenolic or fiber end strips on tail planks of wood pin decks
- Made from extremely durable high-density polyethylene material
- 1-5/8" x 1/2" x 43"

REAR PIN DECK EDGE MOLDING

52-100079-000 - (40-3/4" x 2-3/4" for old-style phenolic pin decks/wood lanes)

52-100244-000 - (40-3/4" x 2-1/16" for old-style phenolic pin decks/synthetic lanes)

84-200083-010 - (40-3/4" x 1-3/8" for integral pin decks/synthetic lanes)

Extend the life of the pin deck by protecting its edges properly.

- Tough edge boards made from X-grade phenolic material can withstand the abuse of flying pins
- Rounded edges protect pins and balls from damage
- 1/2" thick for durability
- The 52-100078-000 edge boards have cut-outs to ensure proper fit. Install these edge boards with glue only (no screws necessary)
- When installing edge boards with glue, use Brunswick Adhesive (11-676047-000)



GUTTER HEADER BLOCK

84-200644-000

Provides an improved lane to gutter installation, eliminating custom fitting and preventing dirt from getting trapped underneath the block. An added back stiffener keeps the block from buckling and improves the movement of lane machine wheels into and out of the gutter. It can be used with all Brunswick round gutters and other round gutters.



ADAPTER GUTTER BLOCKS (BANKSHOT/PBW)

84-200456-001 - (R.H.)

84-200456-002 - (L.H.)

Replace worn adapter blocks to ensure proper ball transition from Bankshot or PBW gutters to the flat gutter. Made from polypropylene material for great strength and durability.

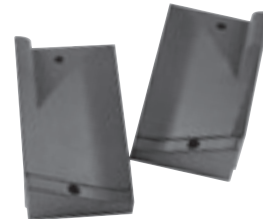

ADAPTER BLOCKS FOR UOS OR VOS V GUTTERS

84-200117-002 - (L.H.)

84-200117-003 - (R.H.)

Precisely contoured to provide a smooth transition from a V gutter to a flat gutter.



ADAPTER BLOCK FOR PLYWOOD OR VOS ROUND GUTTERS

52-100020-600 - (Gray, R.H. one piece)

52-100021-600 - (Gray, L.H. one piece)

Replace worn adapter blocks so gutter balls won't bounce or be damaged when going from the round gutter to the flat gutter.



MY BALL™ ORDER FORM - WORLDWIDE

BILL TO (if a credit card sale, card holder's address is required)

SHIP TO (if different from bill to)

0915-05

CUSTOMER NUMBER			CUSTOMER NUMBER		
CONTACT			CONTACT		
BOWLING CENTER			BOWLING CENTER		
STREET			STREET		
CITY	STATE	ZIP	CITY	STATE	ZIP
PHONE (WILL BE USED ONLY IF WE HAVE A QUESTION) ()		CARD TYPE		CARD NUMBER	
EMAIL		<input type="checkbox"/> Visa <input type="checkbox"/> Am. Express <input type="checkbox"/> Master Card <input type="checkbox"/> Discover		EXPIRATION DATE (MM/YY)	
PURCHASE ORDER NUMBER		SECURITY CODE			
PURCHASE ORDER NUMBER			PURCHASE ORDER TERMS		

PART NUMBER	SIZE/STYLE	QTY	PART NUMBER	SIZE/STYLE	QTY	PART NUMBER	SIZE/STYLE	QTY
6 lb. - Lime Green Pearl			10 lb. - Orange Pearl			13 lb. - Yellow Pearl		
60105544966	NO Drill	_____	60105544930	NO Drill	_____	60105544933	NO Drill	_____
60105544866	XXS-Drilled	_____	60105544630	S-Drilled	_____	60105544533	M-Drilled	_____
60105544766	XS-Drilled	_____	60105544530	M-Drilled	_____	60105544433	L-Drilled	_____
60105544666	S-Drilled	_____	60105544430	L-Drilled	_____	60105544333	XL-Drilled	_____
7 lb. - Fuchsia Pearl			11 lb. - Purple Pearl			14 lb. - Kelly Green Pearl		
60105544937	NO Drill	_____	60105544931	NO Drill	_____	60105544934	NO Drill	_____
60105544737	XS-Drilled	_____	60105544531	M-Drilled	_____	60105544534	M-Drilled	_____
60105544637	S-Drilled	_____	60105544431	L-Drilled	_____	60105544434	L-Drilled	_____
8 lb. - Sky Blue Pearl			12 lb. - Red Pearl			60105544334 XL-Drilled _____		
60105544938	NO Drill	_____	60105544932	NO Drill	_____	60105544234	XXL-Drilled	_____
60105544638	S-Drilled	_____	60105544632	S-Drilled	_____	15 lb. - Dark Blue Pearl		
60105544538	M-Drilled	_____	60105544532	M-Drilled	_____	60105544935	NO Drill	_____
9 lb. - Violet Pearl			60105544432	L-Drilled	_____	60105544435	L-Drilled	_____
60105544939	NO Drill	_____	60105544332	XL-Drilled	_____	60105544335	XL-Drilled	_____
60105544639	S-Drilled	_____				60105544235	XXL-Drilled	_____
60105544539	M-Drilled	_____						

PRICE _____

Note: All drilled balls will be engraved with the ball grip size.

MY FIT BALL™ QTY
 R8010059000 - (Fitting Ball and Display Stand) _____

Please Fax this order to: 231-725-4429
 or email it to: bcss.orders@brunbowl.com



BILLIARDS HOUSE BALL ORDER FORM

BILL TO (if a credit card sale, card holder's address is required)

SHIP TO (if different from bill to)

0915-04

CUSTOMER NUMBER			CUSTOMER NUMBER		
CONTACT			CONTACT		
BOWLING CENTER			BOWLING CENTER		
STREET			STREET		
CITY	STATE	ZIP	CITY	STATE	ZIP
PHONE (WILL BE USED ONLY IF WE HAVE A QUESTION) ()		CARD TYPE		CARD NUMBER	
EMAIL		<input type="checkbox"/> Visa <input type="checkbox"/> Am. Express <input type="checkbox"/> Master Card <input type="checkbox"/> Discover		EXPIRATION DATE (MM/YY)	
				SECURITY CODE	
PURCHASE ORDER NUMBER			PURCHASE ORDER TERMS		

PART NUMBER	SIZE/STYLE	QTY	PART NUMBER	SIZE/STYLE	QTY	PART NUMBER	SIZE/STYLE	QTY
6 lb. - #6 Solid			10 lb. - #10 Striped			13 lb. - #13 Striped		
60105507966	NO Drill	_____	60105507930	NO Drill	_____	60105507933	NO Drill	_____
60105507866	XXS-Drilled	_____	60105507630	S-Drilled	_____	60105507533	M-Drilled	_____
60105507766	XS-Drilled	_____	60105507530	M-Drilled	_____	60105507433	L-Drilled	_____
60105507666	S-Drilled	_____	60105507430	L-Drilled	_____	60105507233	XL-Drilled	_____
7 lb. - #7 Solid			11 lb. - #11 Striped			14 lb. - #14 Striped		
60105507937	NO Drill	_____	60105507931	NO Drill	_____	60105507934	NO Drill	_____
60105507737	XS-Drilled	_____	60105507531	M-Drilled	_____	60105507534	M-Drilled	_____
60105507637	S-Drilled	_____	60105507431	L-Drilled	_____	60105507434	L-Drilled	_____
8 lb. - #8 Solid			12 lb. - #12 Striped			60105507234 XL-Drilled _____		
60105507938	NO Drill	_____	60105507932	NO Drill	_____	60105507134	XXL-Drilled	_____
60105507638	S-Drilled	_____	60105507632	S-Drilled	_____	15 lb. - #15 Striped		
60105507538	M-Drilled	_____	60105507532	M-Drilled	_____	60105507935	NO Drill	_____
9 lb. - #9 Striped			60105507432	L-Drilled	_____	60105507435	L-Drilled	_____
60105507939	NO Drill	_____	60105507232	XL-Drilled	_____	60105507235	XL-Drilled	_____
60105507639	S-Drilled	_____				60105507135	XXL-Drilled	_____
60105507539	M-Drilled	_____						

PRICE _____

MY FIT BALL™ **QTY**
 R8010059000 - (Fitting Ball and Display Stand) _____

Please Fax this order to: 231-725-4429
 or email it to: bcss.orders@brunbowl.com



FLASH LED HOUSE BALL ORDER FORM

BILL TO (if a credit card sale, cardholder's address is required)

SHIP TO (if different from bill to)

CUSTOMER NUMBER			CUSTOMER NUMBER		
CONTACT			CONTACT		
BOWLING CENTER			BOWLING CENTER		
STREET			STREET		
CITY	STATE	ZIP	CITY	STATE	ZIP
PHONE (WILL BE USED ONLY IF WE HAVE A QUESTION) ()		CARD TYPE		CARD NUMBER	
EMAIL		<input type="checkbox"/> Visa	<input type="checkbox"/> Am. Express	EXPIRATION DATE (MM/YY)	
PURCHASE ORDER NUMBER		<input type="checkbox"/> MasterCard	<input type="checkbox"/> Discover	SECURITY CODE	
PURCHASE ORDER TERMS			PURCHASE ORDER TERMS		

PART #	SIZE	QTY	PART #	SIZE	QTY	PART #	SIZE	QTY
8 LB LIME GREEN PEARL			12 LB ORANGE			14 LB KELLY EMERALD GREEN PEARL		
60105986938	NO DRILL		60105986932	NO DRILL		60105986934	NO DRILL	
60105986638	S DRILLED		60105986632	S DRILLED		60105986534	M DRILLED	
60105986538	M DRILLED		60105986532	M DRILLED		60105986434	L DRILLED	
60105986438	L DRILLED		60105986432	L DRILLED		60105986334	XL DRILLED	
10 LB PEARLESSENCE			60105986332	XL DRILLED		60105986234	XXL DRILLED	
60105986930	NO DRILL		60105986232	XXL DRILLED		MY FIT BALL™		
60105986630	S DRILLED					R8010059000	FITTING BALL and DISPLAY STAND	
60105986530	M DRILLED							
60105986430	L DRILLED							
60105986330	XL DRILLED							

PRICE _____

 Fax this order to: 231•725•4429
 or email it to: bcss.orders@brunbowl.com



HYBRID LACE, HOOK AND LOOP, AND YOUTH RENTAL SHOES ORDER

BILL TO (if a credit card sale, cardholder's address is required)

SHIP TO (if different from bill to)

CUSTOMER NUMBER			CUSTOMER NUMBER		
CONTACT			CONTACT		
BOWLING CENTER			BOWLING CENTER		
STREET			STREET		
CITY	STATE	ZIP	CITY	STATE	ZIP
PHONE (WILL BE USED ONLY IF WE HAVE A QUESTION) ()		CARD TYPE		CARD NUMBER	
EMAIL		<input type="checkbox"/> Visa <input type="checkbox"/> Am. Express <input type="checkbox"/> MasterCard <input type="checkbox"/> Discover		EXPIRATION DATE (MM/YY)	
PURCHASE ORDER NUMBER			TERMS		FREIGHT TERMS

HYBRID LACE

HYBRID HOOK AND LOOP

HYBRID YOUTH HOOK AND LOOP

PART #	SIZE	QTY	PART #	SIZE	QTY	PART #	SIZE	QTY
58109305035	MAN3.5/WOMAN5/EUR35		58109306035	MAN3.5/WOMAN5/EUR35		58109304005	YOUTH 5/EUR22	
58109305004	MAN4/WOMAN5.5		58109306004	MAN4/WOMAN5.5		58109304006	YOUTH 6/EUR23	
58109305045	MAN4.5/WOMAN6/EUR36		58109306045	MAN4.5/WOMAN6/EUR36		58109304007	YOUTH 7/EUR24	
58109305005	MAN5/WOMAN6.5/EUR37		58109306005	MAN5/WOMAN6.5/EUR37		58109304008	YOUTH 8/EUR25	
58109305055	MAN5.5/WOMAN7		58109306055	MAN5.5/WOMAN7		58109304009	YOUTH 9/EUR26	
58109305006	MAN6/WOMAN7.5/EUR38		58109306006	MAN6/WOMAN7.5/EUR38		58109304010	YOUTH 10/EUR27	
58109305065	MAN6.5/WOMAN8		58109306065	MAN6.5/WOMAN8		58109304011	YOUTH 11/EUR28	
58109305007	MAN7/WOMAN8.5/EUR39.5		58109306007	MAN7/WOMAN8.5/EUR39.5		58109304012	YOUTH 12/EUR29	
58109305075	MAN7.5/WOMAN9/EUR40		58109306075	MAN7.5/WOMAN9/EUR40		58109304013	YOUTH 13/EUR30	
58109305008	MAN8/WOMAN9.5		58109306008	MAN8/WOMAN9.5		58109304001	YOUTH 1/EUR31	
58109305085	MAN8.5/WOMAN10/EUR41		58109306085	MAN8.5/WOMAN10/EUR41		58109304015	YOUTH 1.5/EUR32	
58109305009	MAN9/WOMAN10.5/EUR42		58109306009	MAN9/WOMAN10.5/EUR42		58109304002	YOUTH 2/EUR33	
58109305095	MAN9.5/WOMAN11		58109306095	MAN9.5/WOMAN11		58109304003	YOUTH 3/W5.5/EUR34	
58109305010	MAN10/WOMAN11.5/EUR43		58109306010	MAN10/WOMAN11.5/EUR43		58109304004	YOUTH 4	
58109305096	MAN10.5/WOMAN12/EUR44		58109306096	MAN10.5/WOMAN12/EUR44				
58109305011	MAN11/WOMAN12.5		58109306011	MAN11/WOMAN12.5				
58109305097	MAN11.5/WOMAN13/EUR45		58109306097	MAN11.5/WOMAN13/EUR45				
58109305012	MAN12/EUR46		58109306012	MAN12/EUR46				
58109305013	MAN13/EUR47		58109306013	MAN13/EUR47				
58109305014	MAN14/EUR48		58109306014	MAN14/EUR48				
58109305015	MAN15/EUR49		58109306015	MAN15/EUR49				
58109305016	MAN16/EUR50		58109306016	MAN16/EUR50				

PRICE _____



Fax this order to: 231•725•4429
or email it to: bcss.orders@brunbowl.com



PREMIUM LACE, PREMIUM HOOK AND LOOP, AND YOUTH RENTAL SHOES ORDER

BILL TO (if a credit card sale, cardholder's address is required)				SHIP TO (if different from bill to)			
CUSTOMER NUMBER				CUSTOMER NUMBER			
CONTACT				CONTACT			
BOWLING CENTER				BOWLING CENTER			
STREET				STREET			
CITY		STATE	ZIP	CITY		STATE	ZIP
PHONE (WILL BE USED ONLY IF WE HAVE A QUESTION) ()		CARD TYPE		CARD NUMBER			
EMAIL		<input type="checkbox"/> Visa <input type="checkbox"/> Am. Express <input type="checkbox"/> MasterCard <input type="checkbox"/> Discover		EXPIRATION DATE (MM/YY)		SECURITY CODE	
PURCHASE ORDER NUMBER				TERMS		FREIGHT TERMS	

PREMIUM LACE			PREMIUM LACE (continued)			PREMIUM HOOK & LOOP (continued)		
PART #	SIZE	QTY	PART #	SIZE	QTY	PART #	SIZE	QTY
58109114001	MAN1/WOMAN2.5/EUR31		58109114015	MAN15/EUR49		58109116096	MAN10.5/WOMAN12/EUR44	
58109114115	MAN1.5/WOMAN3/EUR32		58109114016	MAN16/EUR50		58109116011	MAN11/WOMAN12.5	
58109114002	MAN2/WOMAN3.5/EUR33		58109114017	MAN17/EUR51		58109116097	MAN11.5/WOMAN13/EUR45	
58109114025	MAN2.5/WOMAN4		58109114018	MAN18/EUR53		58109116012	MAN12/EUR46	
58109114003	MAN3/WOMAN4.5/EUR34					58109116013	MAN13/EUR47	
58109114035	MAN3.5/WOMAN5/EUR35		PREMIUM HOOK & LOOP			58109116014	MAN14/EUR48	
58109114004	MAN4/WOMAN5.5		58109116001	MAN1/WOMAN2.5/EUR31		58109116015	MAN15/EUR49	
58109114045	MAN4.5/WOMAN6/EUR36		58109116115	MAN1.5/WOMAN3/EUR32		58109116016	MAN16/EUR50	
58109114005	MAN5/WOMAN6.5/EUR37		58109116002	MAN2/WOMAN3.5/EUR33		58109116017	MAN17/EUR51	
58109114055	MAN5.5/WOMAN7		58109116025	MAN2.5/WOMAN4		58109116018	MAN18/EUR53	
58109114006	MAN6/WOMAN7.5/EUR38		58109116003	MAN3/WOMAN4.5/EUR34				
58109114065	MAN6.5/WOMAN8		58109116035	MAN3.5/WOMAN5/EUR35		YOUTH		
58109114007	MAN7/WOMAN8.5/EUR39		58109116004	MAN4/WOMAN5.5		58109115007	YOUTH 7/EUR24	
58109114075	MAN7.5/WOMAN9/EUR40		58109116045	MAN4.5/WOMAN6/EUR36		58109115008	YOUTH 8/EUR25	
58109114008	MAN8/WOMAN9.5		58109116005	MAN5/WOMAN6.5/EUR37		58109115009	YOUTH 9/EUR26	
58109114085	MAN8.5/WOMAN10/EUR41		58109116055	MAN5.5/WOMAN7		58109115010	YOUTH 10/EUR27	
58109114009	MAN9/WOMAN10.5/EUR42		58109116006	MAN6/WOMAN7.5/EUR38		58109115011	YOUTH 11/EUR28	
58109114095	MAN9.5/WOMAN11		58109116065	MAN6.5/WOMAN8		58109115012	YOUTH 12/EUR29	
58109114010	MAN10/WOMAN11.5/EUR43		58109116007	MAN7/WOMAN8.5/EUR39		58109115013	YOUTH 13/EUR30	
58109114096	MAN10.5/WOMAN12/EUR44		58109116075	MAN7.5/WOMAN9/EUR40		58109115001	YOUTH 1/EUR31	
58109114011	MAN11/WOMAN12.5		58109116008	MAN8/WOMAN9.5		58109115002	YOUTH 2/EUR33	
58109114097	MAN11.5/WOMAN13/EUR45		58109116085	MAN8.5/WOMAN10/EUR41		58109115003	YOUTH 3/W5.5/EUR34	
58109114012	MAN12/EUR46		58109116009	MAN9/WOMAN10.5/EUR42		58109115004	YOUTH M4/W5.5	
58109114013	MAN13/EUR47		58109116095	MAN9.5/WOMAN11				
58109114014	MAN14/EUR48		58109116010	MAN10/WOMAN11.5/EUR43				

PRICE _____



Fax this order to: 231•725•4429
or email it to: bcss.orders@brunbowl.com



VALUE SPORT RENTAL SHOES ORDER

BILL TO (if a credit card sale, cardholder's address is required)				SHIP TO (if different from bill to)			
CUSTOMER NUMBER				CUSTOMER NUMBER			
CONTACT				CONTACT			
BOWLING CENTER				BOWLING CENTER			
STREET				STREET			
CITY		STATE	ZIP	CITY		STATE	ZIP
PHONE (WILL BE USED ONLY IF WE HAVE A QUESTION) ()		CARD TYPE		CARD NUMBER			
EMAIL		<input type="checkbox"/> Visa <input type="checkbox"/> Am. Express		EXPIRATION DATE (MM/YY)		SECURITY CODE	
		<input type="checkbox"/> MasterCard <input type="checkbox"/> Discover					
PURCHASE ORDER NUMBER				TERMS		FREIGHT TERMS	

VALUE SPORT ADULT LACE		
PART #	SIZE	QTY
58109303004	MAN4/WOMAN5.5	
58109303045	MAN4.5/WOMAN6/EUR36	
58109303005	MAN5/WOMAN6.5/EUR37	
58109303055	MAN5.5/WOMAN7	
58109303006	MAN6/WOMAN7.5/EUR38.5	
58109303065	MAN6.5/WOMAN8	
58109303007	MAN7/WOMAN8.5/39.5	
58109303075	MAN7.5/WOMAN9/EUR40	
58109303008	MAN8/WOMAN9.5/EUR40.5	
58109303085	MAN8.5/WOMAN10/EUR41	
58109303009	MAN9/WOMAN10.5/EUR42	
58109303095	MAN9.5/WOMAN11	
58109303010	MAN10/WOMAN11.5/EUR43	

VALUE SPORT ADULT LACE (continued)		
PART #	SIZE	QTY
58109303096	MAN10.5/WOMAN12/EUR44	
58109303011	MAN11/WOMAN12.5	
58109303097	MAN11.5/WOMAN13/EUR45	
58109303012	MAN12/EUR46	
58109303013	MAN13/EUR47	
58109303014	MAN14/EUR48	
58109303015	MAN15/EUR49	
58109303016	MAN16/EUR50	

VALUE SPORT YOUTH LACE		
PART #	SIZE	QTY
58109302007	YOUTH VALUE 7/EUR24	
58109302008	YOUTH VALUE 8/EUR25	
58109302009	YOUTH VALUE 9/EUR26	
58109302010	YOUTH VALUE 10/EUR27	
58109302011	YOUTH VALUE 11/EUR28	
58109302012	YOUTH VALUE 12/EUR29	
58109302013	YOUTH VALUE 13/EUR30	
58109302001	YOUTH VALUE 1/EUR31	
58109302015	YOUTH VALUE 1.5/EUR32	
58109302002	YOUTH VALUE 2/EUR33	
58109302025	YOUTH VALUE 2.5	
58109302003	YOUTH VALUE 3/W5.5/EUR34	
58109302035	YOUTH VALUE 3.5/EUR35	

PRICE _____



Fax this order to: 231•725•4429
or email it to: bcss.orders@brunbowl.com

BILL TO (if a credit card sale, cardholder's address is required)			SHIP TO (if different from bill to)		
CUSTOMER NUMBER			CUSTOMER NUMBER		
CONTACT			CONTACT		
BOWLING CENTER			BOWLING CENTER		
STREET			STREET		
CITY	STATE	ZIP	CITY	STATE	ZIP
PHONE (WILL BE USED ONLY IF WE HAVE A QUESTION) ()		CARD TYPE		CARD NUMBER	
EMAIL		<input type="checkbox"/> Visa <input type="checkbox"/> Am. Express <input type="checkbox"/> MasterCard <input type="checkbox"/> Discover		EXPIRATION DATE (MM/YY)	
PURCHASE ORDER NUMBER			TERMS		FREIGHT TERMS

MAX PINS

PART #	DESCRIPTION	QTY	PRICE
63861165167	MAX CROWN GRAPHIC GLOW SET		
63861166167	MAX STRIPE GRAPHIC GLOW SET		
63861167167	MAX RED CROWN SET		
63861168167	MAX RED STRIPE SET		

SCORE KING PINS

PART #	DESCRIPTION	QTY	PRICE
63861180167	SCORE KING GLOW CROWN SET		
63861182167	SCORE KING GLOW STRIP SET		
63861179167	SCORE KING RED CROWN SET		
63861181167	SCORE KING RED STRIPE SET		

NOVELTY PINS

PART #	DESCRIPTION	QTY	PRICE
62861092167	HAPPY BIRTHDAY PIN SET		
62861092000	HAPPY BIRTHDAY PIN SINGLE		
63861157167	TROPHY PIN SET		
63861157000	TROPHY PIN SINGLE		
63861161167	MAGENTA COLORED PIN SET		
63861161000	MAGENTA COLORED PIN SINGLE		
63861137167	GREEN COLORED PIN SET		
63861137000	GREEN COLORED PIN SINGLE		
63861138167	YELLOW COLORED PIN SET		
63861138000	YELLOW COLORED PIN SINGLE		
63861139167	ORANGE COLORED PIN SET		
63861139000	ORANGE COLORED PIN SINGLE		

PRICE _____



Fax this order to: 231•725•4429
or email it to: bcss.orders@brunbowl.com

BILL TO (if a credit card sale, cardholder's address is required)				SHIP TO (if different from bill to)			
CUSTOMER NUMBER				CUSTOMER NUMBER			
CONTACT				CONTACT			
BOWLING CENTER				BOWLING CENTER			
STREET				STREET			
CITY		STATE	ZIP	CITY		STATE	ZIP
PHONE (WILL BE USED ONLY IF WE HAVE A QUESTION) ()		CARD TYPE		CARD NUMBER			
EMAIL		<input type="checkbox"/> Visa <input type="checkbox"/> Am. Express <input type="checkbox"/> MasterCard <input type="checkbox"/> Discover		EXPIRATION DATE (MM/YY)		SECURITY CODE	
PURCHASE ORDER NUMBER				TERMS		FREIGHT TERMS	

3 TIER CART

PART #	COLOR	QTY
62860312000	BLACK	
62860312001	GREEN	
62860312002	YELLOW	
62860312003	BLUE	
62860312004	SILVER	

PRICE _____

2 TIER CART

PART #	COLOR	QTY
62860311000	BLACK	
62860311001	GREEN	
62860311002	YELLOW	
62860311003	BLUE	
62860311004	SILVER	

PRICE _____

BALL RAMP

PART #	COLOR	QTY
62860310000	BLACK	
62860310001	GREEN	
62860310002	YELLOW	
62860310003	BLUE	
62860310004	SILVER	

PRICE _____



Fax this order to: 231•725•4429
or email it to: bcss.orders@brunbowl.com



Brunswick®

525 West Laketon Avenue
Muskegon, MI 49441-2601 USA
1-800-Yes-Bowl (Options 2,2,*)
1-231-725-4966 (Options 2,2,*)
inquiries@brunswickbowling.com
www.brunswickbowling.com

Go to www.brunswickbowling.com/contact to find a local Brunswick Sales Representative

Kegel is a registered trademark of KEGEL, LLC. Surlyn is a registered trademark of E.I. du Pont de Nemours and Company. USBC is a registered trademark of United States Bowling Congress, Inc. Windows is a registered trademark of Microsoft Corporation in the United States and/or other countries. IBM is a registered trademark of International Business Machines Corporation. All other trademarks belong to Brunswick Bowling Products, LLC.

Brunswick is committed to continuous improvement. As a result, all specifications and options are subject to change without notice. Not for reproduction without the express written consent of Brunswick Bowling Products, LLC.

©2018 Brunswick Bowling Products, LLC. Printed in the USA. • Item #10-095400-002 • Form #0618-07

2018 CATALOG