



*Service Parts Catalog*

---

**Authority22**  
**Lane Machine**  
**Version 2.0**

August 2011 / 14-900089-000

**Brunswick**   
CUSTOMER SERVICE  
A tradition in excellence.

## **Authority22 Lane Machine Version 2.0 Service Parts Catalog**

© August 2011 by the Brunswick Bowling and Billiards Corporation. All rights reserved.

Authority22 is a registered trademark of the Brunswick Bowling and Billiards Corporation.

Reorder Part No. 14-900089-000

Notice: If available, updates to this catalog can be found on-line at [www.brunswickbowling.com](http://www.brunswickbowling.com).

All information contained in this document is subject to change without notice.

Brunswick Bowling & Billiards Corporation  
525 West Laketon Avenue  
P.O. Box 329  
Muskegon, MI 49443-0329  
U.S.A.

231.725.3300

# Contents

## Section A - Cleaning System

Dusting System .....	2A
Cleaner Delivery System .....	4A
Squeegee & Waste System .....	6A

## Section B - Chassis & Drive System

Chassis System .....	2B
Traction Drive System .....	4B
Rear Distance Shaft .....	6B

## Section C - Conditioning System

Conditioning Delivery System .....	2C
Conditioner Buffering System .....	4C

## Section D - Cover & Handle System

Hood System .....	2D
Handle System .....	4D

## Section E - Electrical System

Graphical User Interface .....	2E
Electrical Enclosure .....	4E
Power Cables for DC Output .....	6E
Power Cables for AC Output .....	8E
Power Cables for Sensors .....	10E
Power Cord .....	12E

## Section F - Miscellaneous

Tune Up Kits .....	2F
Fuses .....	3F
Extraction Tools .....	4F
Pins & Sockets .....	5F
Tools .....	6F
Tubing .....	7F
Miscellaneous .....	8F

## **Select Only Genuine Brunswick Replacement Parts for Brunswick Equipment**

You purchased the best when you bought Brunswick equipment. Insist on the best in replacement parts. Buy Genuine Brunswick Replacement Parts to keep your equipment in top-notch working condition.

### **Here's why you should insist on Brunswick Replacement Parts for your Brunswick equipment:**

- Only Brunswick replacement parts are guaranteed to be the same, top quality, heavy-duty parts that go into the world's finest equipment by Brunswick.
- Rigid quality control assures maximum protection against part defect or failure.
- Full-time testing of all equipment and continual updating of parts provides the latest improvements.
- Each improved part is designed to be interchangeable with the part it is replacing.
- Efficient cost methods of production and design, reduce the cost of parts.

To place an order contact your certified Brunswick parts distributor or Brunswick at 1-800-YES-BOWL or 231-725-3300. Authorized Brunswick part distributors listings can be found on-line at [www.brunswickbowling.com](http://www.brunswickbowling.com)

For catalog comments or questions please e-mail: [aftermarketcatalogs@brunbowl.com](mailto:aftermarketcatalogs@brunbowl.com)

## WARRANTY

- Warranty coverage starts with date of purchase.
- The warranty coverage period is 90 days on materials.
- Repair or replacement parts is at the option of Brunswick.
- Call your authorized Brunswick Parts Distributor for parts warranty transaction process.

*Intentionally Blank Page*

Section A

# **Cleaning System**

Index

<b>No.</b>	<b>Part No.</b>	<b>Description</b>
1.	14-100074-000	Clutch Assembly
2.	11-616025-000	Start/Stop Switch
3.	14-100277-000	Duster Cloth Motor
4.	14-100081-000	Contact Roller
5.	62-860207-000	Cloth Supply Roll
6.	61-200008-000	Cloth Take Up Roll
7.	11-005178-015	Socket Head Cap Screw (1/4-20 x 1/2")
8.	14-100084-000	Contact Roller Pivot Arm
9.	11-581011-000	Spring
10.	14-100074-003	Leather Pad
11.	14-100078-000	Cloth Take Up Hub Assembly
12.	11-345320-015	Roll Pin
13.	14-100081-002	Foam Tube
14.	14-100075-000	Duster Cloth Clutch Hub

## Dusting System



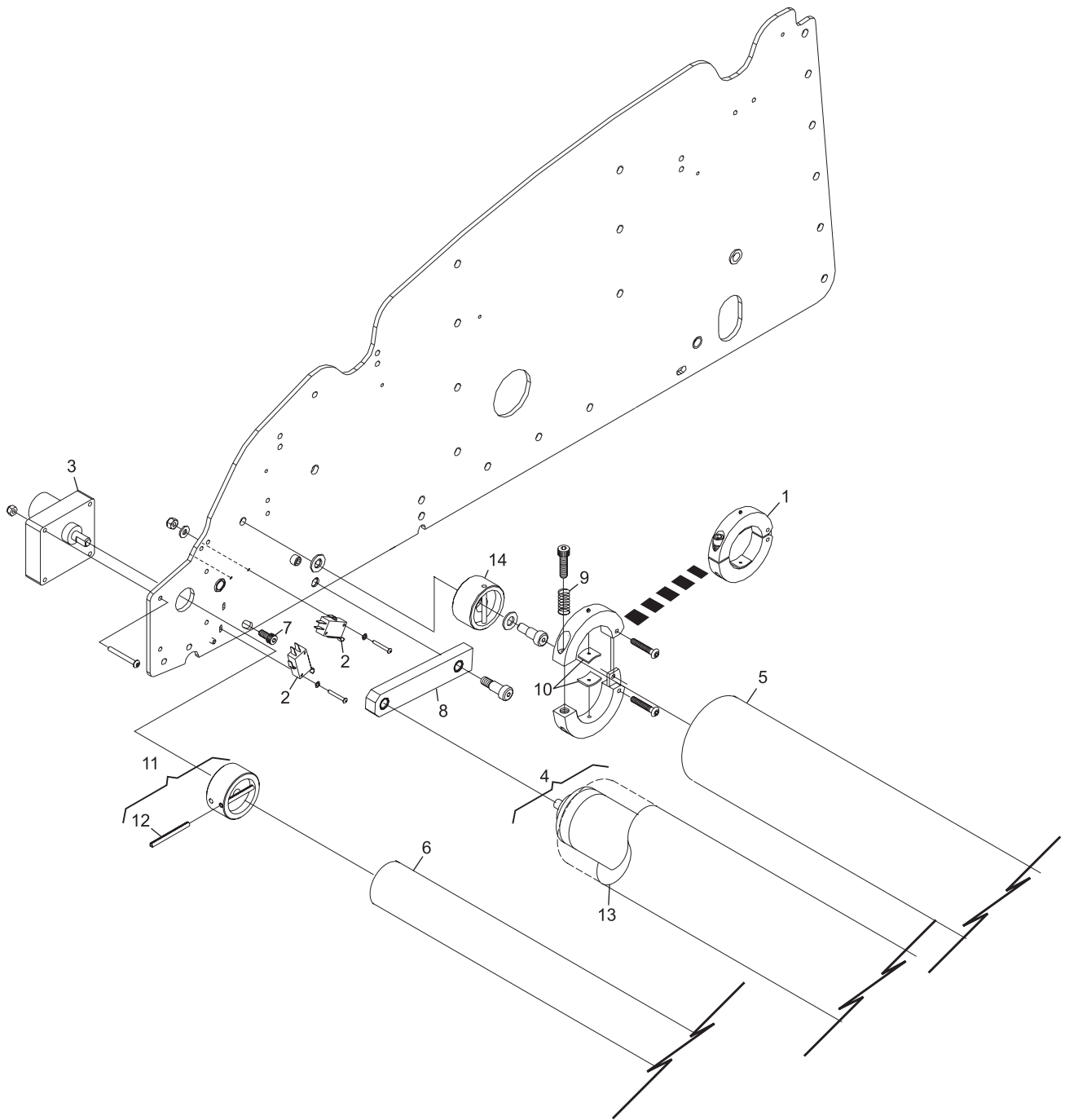

## Dusting System

Index

No.	Part No.	Description
1.	14-100435-000	Supply Tank Assembly
2.	11-655037-000	Vent Valve
3.	11-696956-000	Level Float Sensor
4.	14-100353-000	Line Strainer Assembly
5.	11-655065-000	Pressure Gauge
6.	14-100444-000	Manifold - complete
7.	14-860228-115	Pump w/Fittings 115VAC
	14-860228-230	Pump w/Fittings 230VAC
8.	14-100086-002	Valve w/Solenoid and Connectors
9.	11-655064-000	Pinch Valve
10.	11-655053-000	Fitting - 90° Elbow (3/8")
11.	11-655052-000	Fitting - 90° Elbow (1/4")
12.	14-100449-000	Cap w/Seal
13.	14-100440-002	Tank Mounting Bracket (left hand)
14.	11-655039-001	Tube (1/4 O.D. x 1.25")
15.	11-655038-000	Check Valve (1/8 x 1/8)
16.	14-100440-001	Tank Mounting Bracket (right hand)
17.	11-014265-000	Screw (1/4-20 x 1/2")
18.	14-100424-000	Grommet
19.	14-100430-001	Grommet
20.	11-625602-000	O-Ring (11/32)
21.	14-100430-000	Grommet
22.	11-282004-002	Tubing (3/8" x 10-3/8")
23.	14-100438-000	Pump Mounting Bracket
24.	11-191753-000	Washer
25.	11-170005-015	Lock Nut (#10-24)
26.	11-006061-015	Screw (#8-32 x 3/8")
27.	11-199002-015	Lockwasher (#8)
28.	11-655058-000	Tool Holder
29.	11-185257-000	Standoff (#8-32 x 1-1/4")
30.	11-199003-015	Lockwasher (#10)
31.	11-006095-000	Screw (#10-24 x 1-1/4")
32.	14-100405-000	Jumper w/Ferrite Core Cable Assembly
33.	11-603106-000	Cable Tie
34.	14-100090-000	Mounting Bracket
35.	11-012056-015	Screw (#8-32 x 1-4")
36.	11-655048-000	Connector Fitting (3/8")
37.	11-655044-000	Line Strainer (200 Mesh)
38.	11-655047-000	Adjustable Ball Fitting (1/8 NPT)
39.	11-655054-000	Straight Fitting (1/4 x 3/8 NPT)
40.	11-655057-000	Fitting - 90° Elbow (1/8 x 1/8)
41.	14-100468-000	Low Pressure Switch Assembly
42.	11-655056-000	Nozzle Body
43.	11-655002-000	Strainer (200 Mesh)
44.	11-655003-000	Nozzle (110°)
45.	11-655004-000	Tip Retainer
46.	14-100447-000	Spray Nozzel Assembly
47.	11-655015-000	Fitting - Male (1/4 OD Tube x 1/8 NPT)
48.	11-655061-000	Union "Y" (1/4 Tube)
49.	11-655060-000	Union "Y" (1/4 Tube x 3/8 Pipe)

## Cleaner Delivery System

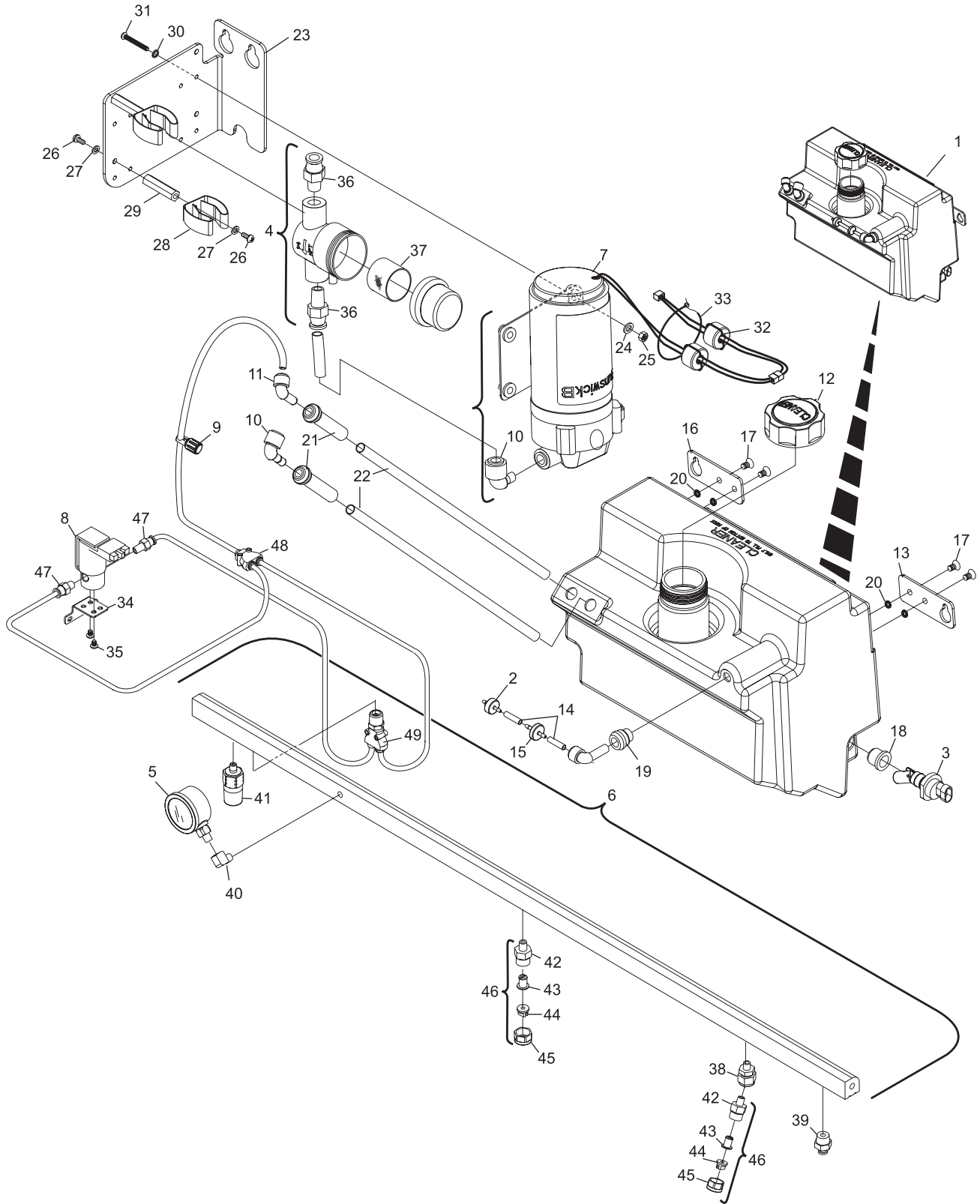

### Cleaner Delivery System

## Index

No.	Part No.	Description
1.	11-616026-000	Switch
2.	14-100060-000	Pivot Arms
3.	14-100065-000	Lifting Linkage
4.	14-100275-120	Vacuum Motor Assembly (120VAC)
	14-100275-240	Vacuum Motor Assembly (240VAC)
5.	14-100301-000	Waste Tank
6.	11-603204-000	Hose Clamp
7.	11-655034-000	Hose
8.	11-655035-000	Hose Cuff
9.	14-100061-000	Lift Rod
10.	11-537051-000	Retaining Ring (external)
11.	11-192576-000	Shim
12.	11-388000-000	Spacer (1/4" I.D. x 1/2" O.D. x 1-1/4")
13.	11-005193-015	Screw (1/4-20 x 2-1/4")
14.	11-190010-015	Flat Washer (1/4)
15.	14-100093-000	Vacuum Motor Bracket
16.	11-081050-000	Screw (#10-32 x 1/2")
17.	11-171504-000	Hex Serrated Head Nut (1/4-20)
18.	14-100097-000	Vacuum Exhaust Deflector Assembly
19.	11-006116-000	Screw (#10-32 x 3/8")
20.	11-199003-015	Lock Washer (#10)
21.	14-100066-000	Vacuum Exhaust Deflector
22.	14-100106-000	Side Exhaust Deflector Felt
23.	14-860222-000	Adhesive (for felt)
24.	14-100104-000	Top Exhaust Deflector Felt
25.	14-100377-000	Diffuser Bracket
26.	14-100062-000	Motor Mount Bracket
27.	11-006010-000	Screw (#4-40 x 1")
28.	11-199000-015	Internal Tooth Lockwasher (#4)
29.	11-125003-015	Nut (#8-32)
30.	11-170004-015	Locknut (#8-32)
31.	14-100268-000	Motor Assembly
32.	11-006071-000	Screw (#8-32 x 1-1/2")
33.	14-100037-002	Squeegee Up/Down Cam
34.	11-105454-000	Set Screw (1/4-28 x 3/8")
35.	14-100310-000	Nut Plate
36.	11-581011-000	Spring
37.	11-012353-015	Pan Head Cap Screw (#10-32 x 1-1/4")
38.	14-100461-000	V-Squeegee Assembly - complete
39.	14-100258-000	Up/Down Switch Cable Assembly
40.	11-007776-000	Flat Head Cap Screw (1/4-20 X 5/8")
41.	14-100457-001	Inner Squeegee Extrusion (left hand)
42.	11-006701-000	Button Head Cap Screw (1/4-20 X 5/8")
43.	11-007775-000	Flat Head Cap Screw (1/4-20 X 1/2")
44.	14-100523-000	V-Squeegee Blade Assembly
45.	14-100457-002	Inner Squeegee Extrusion (right hand)
46.	14-100521-000	Absorbent Wiper Assembly
47.	14-100488-000	Alignment Pin
48.	14-100455-002	Outer Squeegee Extrusion (right hand)
49.	14-100458-002	Arm Bracket (right hand)
50.	14-100460-000	Vacuum Head Assembly
51.	14-100458-001	Arm Bracket (left hand)
52.	14-100455-001	Outer Squeegee Extrusion (left hand)
53.	11-006702-000	Button Head Cap Screw (1/4-20 x 3/4")

## Squeegee & Waste System

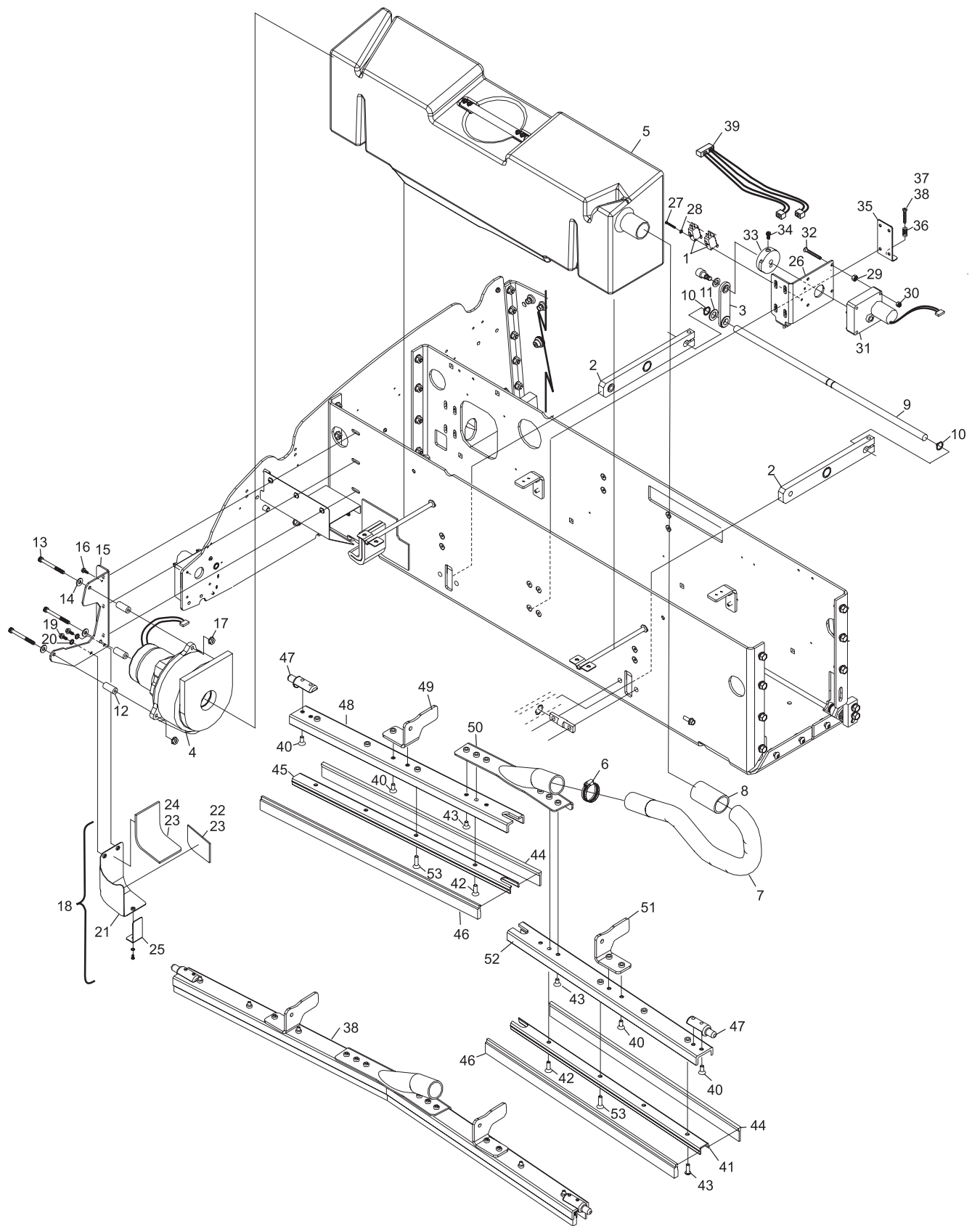

## Squeegee & Waste System

*Intentionally Blank Page*

Section B

**Chassis & Drive System**

**Index**

<b>No.</b>	<b>Part No.</b>	<b>Description</b>
1.	14-100098-000	Font Handle/Bumper
2.	14-100235-000	End of Lane Sensor
3.	14-100282-002	Transition/Guide Wheel Assembly (right hand) - manufactured on machines serial number 2349 and below
4.	14-100282-001	Transition/Guide Wheel Assembly (left hand) - manufactured on machines serial numbers 2349 and below
5.	14-860241-002	Transition/Guide Wheel Assembly (right hand) - manufactured on machines serial numbers 2350 and above, can be used in place of 14-100282-002
6.	14-860241-001	Transition/Guide Wheel Assembly (left hand) - manufactured on machines serial numbers 2350 and above, can be used in place of 14-100282-001
7.	11-625601-000	O-Ring
8.	11-695010-000	Dual Wheel Caster (2")
	*14-860240-000	Heavy Duty Caster Assembly (2") Available as an assembly only - must replace both left hand and right hand 2" casters to change to heavy duty
9.	14-100018-000	Cast Mount Bracket
10.	11-010787-000	Hex Head Serrated Flange Screw (5/16-18 x 1")
11.	11-010786-000	Hex Head Serrated Flange Head Screw (3/8-16 x 1-1/4")
12.	11-191014-009	Flat Washer (3/8)
13.	11-005268-015	Socket Head Cap Screw (5/16-18 x 1-1/2")
14.	11-171501-000	Hex Nut (5/16-18)
15.	11-696946-000	Wheel (8")
16.	11-106585-009	Screw (3/8-16 x 1/2 O.D. x 2-1/2")
17.	11-190018-015	Washer (1/2)
18.	11-192574-000	Shim (3/4 I.D. x 1-1/8 O.D. x .062)
19.	11-190010-015	Washer (1/4)
20.	11-006218-015	Button Head Socket Cap Screw (1/4-28 x 1/2")
21.	11-185281-000	Spacer (1/2 x 1/16 x 1/32")
22.	14-100531-000	Transition Wheel Assembly
23.	11-185279-000	Spacer (1/2 I.D. x 1/32")
24.	14-100279-000	Front Guide Wheel
25.	11-581010-000	Compression Spring
26.	14-100861-000	Transition Guide Roller Shaft
27.	14-100281-000	Transition Guide Roller Shaft
28.	11-530017-001	Retaining Ring (external)
29.	11-192576-000	Shim (1/2 I.D. x 7/8 O.D.)
30.	14-100207-000	Front Brace /Transition Wheel Assembly
31.	14-100030-000	Guide Wheel
32.	14-100139-000	Swivel Caster Assembly (3")
33.	14-100138-000	Swivel Caster (3")
34.	11-002246-015	Hex Head Cap Screw (1/2-13 x 1-1/2")
35.	11-195018-015	Lockwasher (1/2)
36.	14-100036-000	Guide Wheel Assembly

\* *Not Illustrated*

## Chassis System



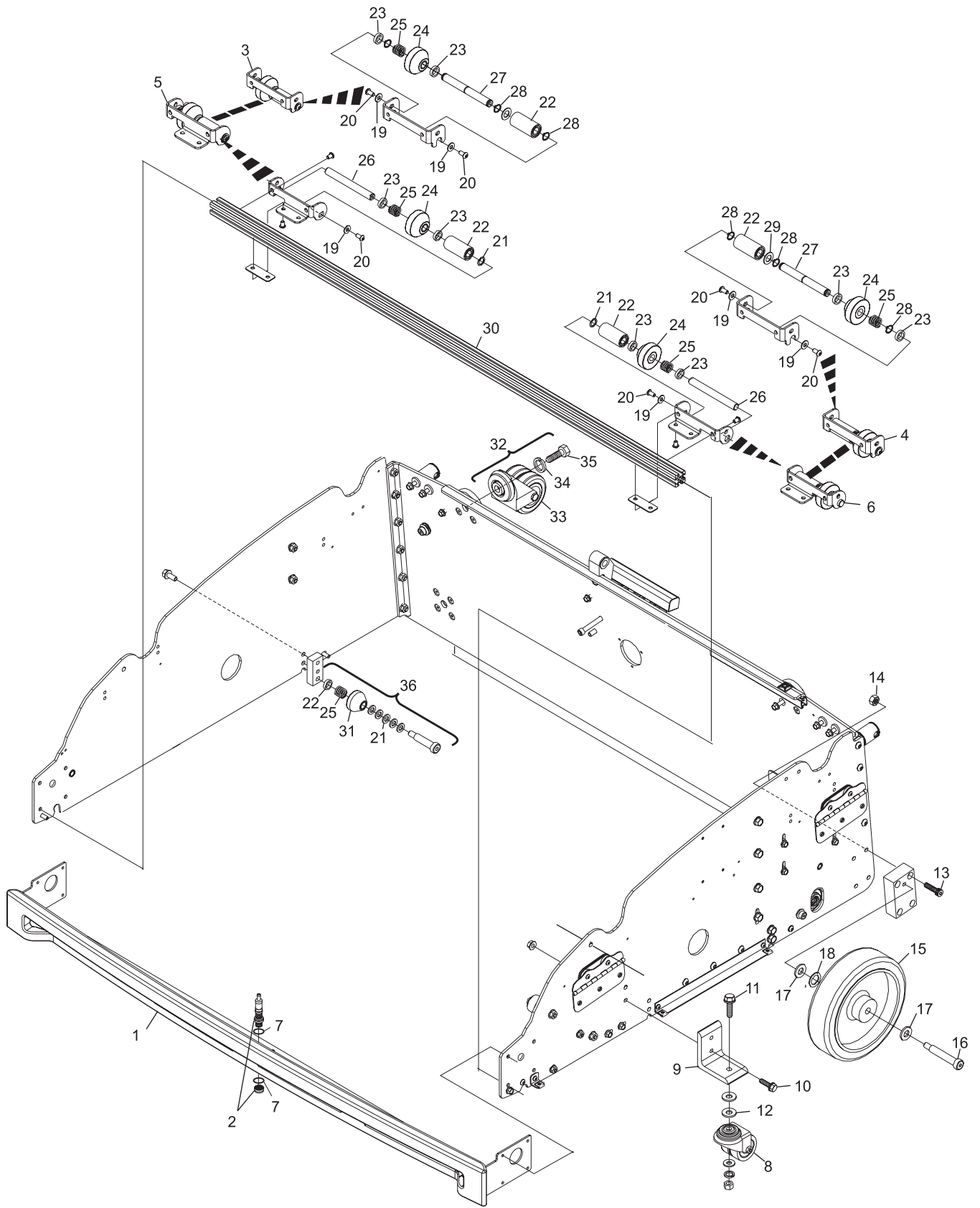

### Chassis System

**Index**

<b>No.</b>	<b>Part No.</b>	<b>Description</b>
1.	14-100233-000	Drive Motor w/Cable Assembly
2.	11-002027-009	Screw (1/4-28 - 5/8")
3.	11-195014-015	Lockwasher (1/4)
4.	11-190010-015	Flat Washer (1/4)
5.	14-100005-001	Motor Mount Bracket
6.	11-491103-000	Sprocket (12 tooth)
7.	11-601011-000	Roller Chain
8.	11-171504-000	Nut (1/4-20)
9.	14-100558-000	Drive Motor Assembly w/Bracket
10.	11-600001-000	Connecting Link (roller chain)
11.	14-100006-000	Drive Wheel Assembly
12.	11-105452-000	Set Screw (5/16-24 x 3/8")
13.	11-050007-000	Woodruff Key
14.	11-491101-000	Sprocket (10 tooth)
15.	14-100015-000	Drive Shaft
16.	14-100026-000	Bearing Block (short shaft)
17.	14-100027-000	Drive Shaft Wheel Assembly
18.	11-010785-000	Screw (1/4-20 x 3/4")

**Traction Drive System**

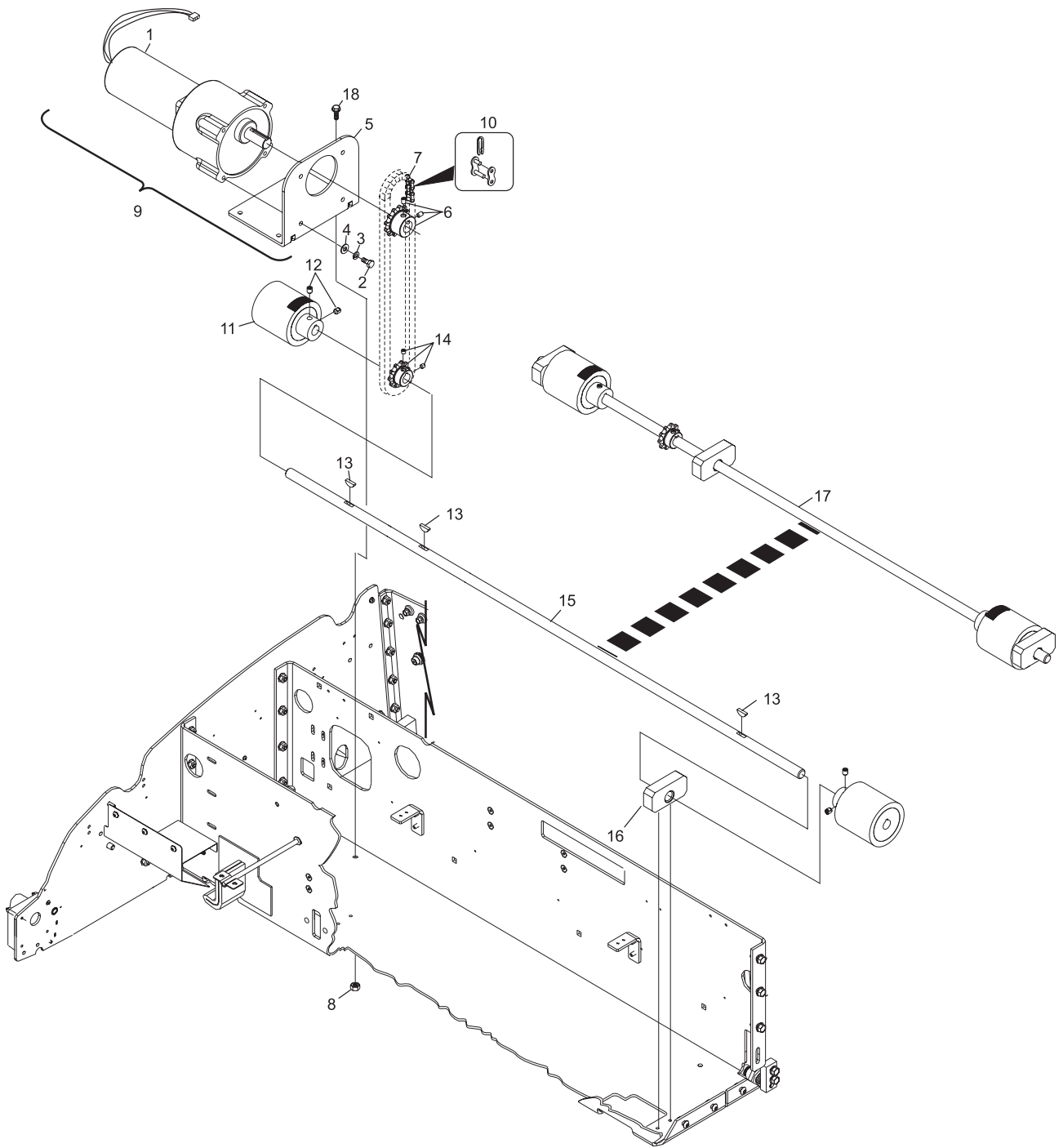

## Traction Drive System

**Index**

<b>No.</b>	<b>Part No.</b>	<b>Description</b>
1.	14-100254-000	Speed Sensor Assembly
2.	14-100541-000	Speed Sensor Bracket
3.	11-010790-000	Hex Head Serrated Flange Screw (1/4-20 x 3/8")
4.	14-100073-000	Position Sensor Wheel Assembly
5.	14-860225-000	Distance Encoder Sprocket Shield
6.	14-100059-001	Bearing Block (left hand)
7.	14-100006-000	Drive Wheel Assembly
8.	11-050007-000	Woodruff Key (3/16 x 3/4)
9.	11-105452-000	Set Screw (5/16-24 x 3/8")
10.	14-100015-000	Drive Shaft
11.	14-100059-002	Bearing Block (right hand)
12.	11-420144-000	Bearing Sleeve (5/8 ID x 13/16 OD)

**Rear Distance Shaft**

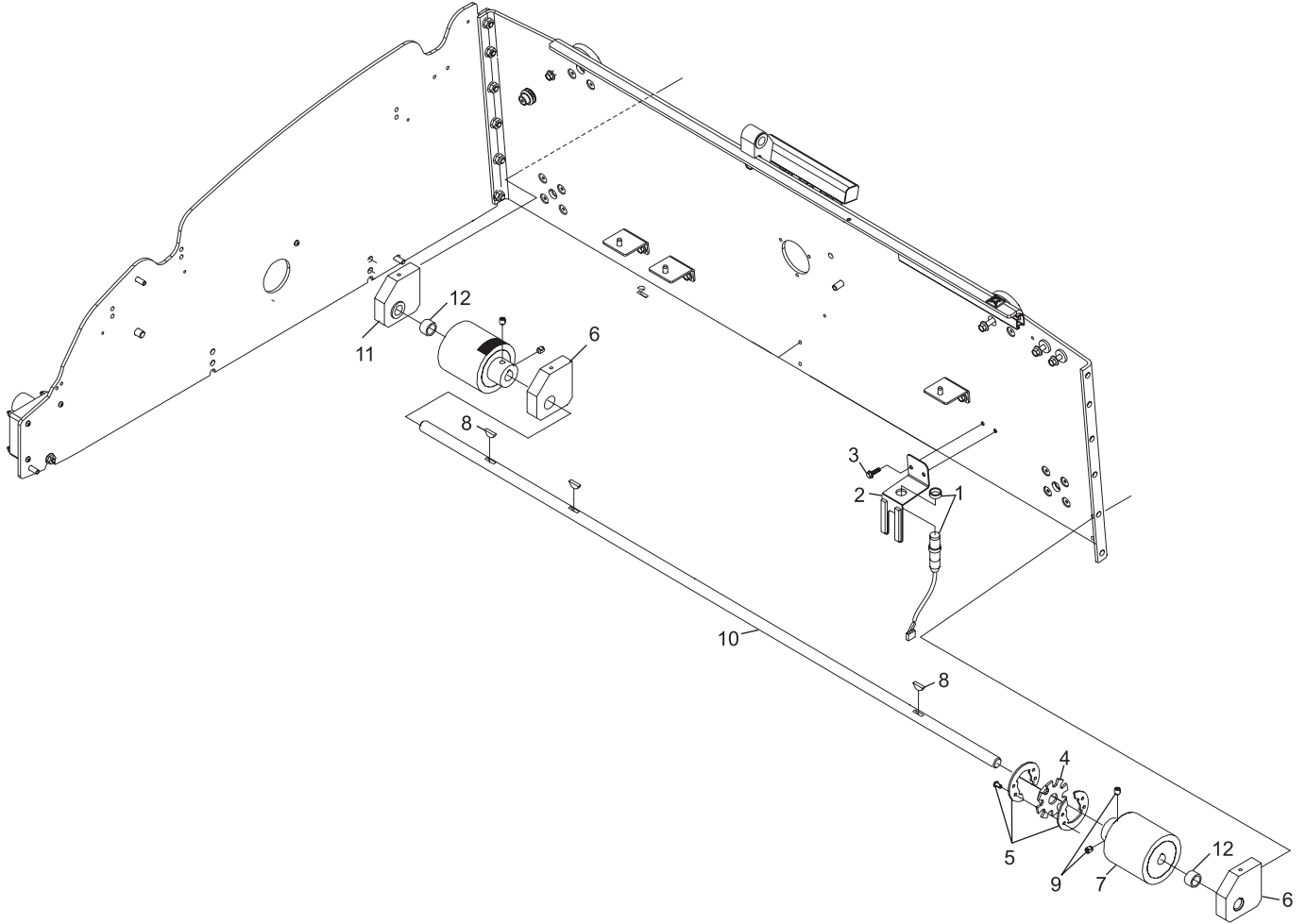

**Rear Distance Shaft**

*Intentionally Blank Page*

Section C

**Conditioning System**

**Index**

<b>No.</b>	<b>Part No.</b>	<b>Description</b>
1.	14-100086-001	Solenoid Valve w/Connectors
2.	11-655016-000	Filter/Muffler
3.	14-100090-000	Mounting Bracket
4.	11-012056-015	Screw (#8-32 x 1/4)
5.	11-655017-000	Swivel Elbow Fitting
6.	14-100025-000	Vent Overflow Line Strainer
7.	11-655026-000	Swivel Elbow Fitting
8.	11-655044-000	Line Strainer (200 mesh)
9.	14-100436-000	Conditioner Tank Assembly - complete
10.	11-655053-000	90° Elbow Fitting (3/8 tube x 3/8 stem)
11.	11-665052-000	90° Elbow Fitting (3/8 tube x 3/8 stem)
12.	14-100430-000	Grommet (modified)
13.	14-100437-000	Conditioner Tank Cap
14.	14-100440-002	Tank Mounting Bracket (left hand)
15.	11-014265-000	Screw (1/4-20 x 1/2")
16.	11-696956-000	Horizontal Level Sensor
17.	14-100424-000	Grommet Tank Level Sensor
18.	14-100440-001	Tank Mounting Bracket (right hand)
19.	11-625602-000	O-Ring (11/32")
20.	14-100580-000	Foam - Conditioner Tank Neck
21.	14-100430-000	Grommet (tank)
22.	11-282003-001	Tubing (3/8 O.D. x 6-1/2")
23.	14-100478-000	Line Strainer Assembly
24.	11-655048-000	Connector Fitting (3/8)
25.	11-655024-000	Line Strainer (40 mesh)
26.	14-100405-000	Jumper Wire w/Ferrite Core Cable Assembly
27.	14-100438-000	Pump Mounting Bracket
28.	11-006095-000	Button Head Cap Screw (#10-24 x 1-1/4")
29.	14-860229-230	Conditioner Pump w/Fitting Assembly (230VAC)
	14-860229-115	Conditioner Pump w/Fitting Assembly (115VAC)
30.	11-191753-000	Washer (1/4)
31.	11-170005-015	Lock Nut (#10-24)
32.	11-006061-015	Button Head Socket Cap Screw (#8-32 x 3/8")
33.	11-199002-015	Lockwasher - Internal Tooth (#8)
34.	11-655058-000	Tool Holder
35.	11-185257-000	Standoff (#8-32 x 1-1/4")
36.	11-199003-015	Lockwasher - Internal Tooth (#10)
37.	11-199005-001	Lockwasher (1/4)
38.	11-006178-001	Button Head Cap Screw (1/4-20 x 1/2")
39.	14-100481-000	Assembly Conditioner Filter
40.	11-655029-001	Filter
41.	11-655054-000	Swivel Elbow Fitting (3/8 NPT)
	*11-655079-000	Compression fitting (3/8 NPT) Can be used to replace Swivel Elbow Fitting - on inlet side only
42.	14-100167-000	Mounting Bracket
43.	11-655054-000	Straight Fitting
44.	11-655040-000	Swivel Elbow (male)
45.	14-100323-000	Injector
46.	14-100483-115	Conditioner Rail w/Connector Assembly (115VAC)
	14-100483-230	Conditioner Rail w/Connector Assembly (230VAC)
47.	14-100328-115	Heater Assembly (115VAC)
	14-100328-230	Heater Assembly (230VAC)
48.	11-655040-000	Fitting (3/8 tube to 3/8 NPT)
49.	11-696944-000	Coolant Temperature Sensor
50.	14-100071-000	Rail - Accumulator
51.	11-655007-000	Accumulator Diaphragm
52.	11-625600-000	"O" Ring
53.	11-655006-000	Fitting (3/4-16 to 3/8 NPT)
54.	11-696945-000	Sensor Pressure (100 PSI)
55.	11-655054-000	Connector Fitting (male)
56.	11-655065-000	Pressure Dial (0-6 PSI)
57.	11-655015-000	Straight Fitting (1/8 NPT)
58.	11-655063-000	Straight Fitting (1/8 NPT)

\* Not Illustrated

**Conditioning Delivery System**



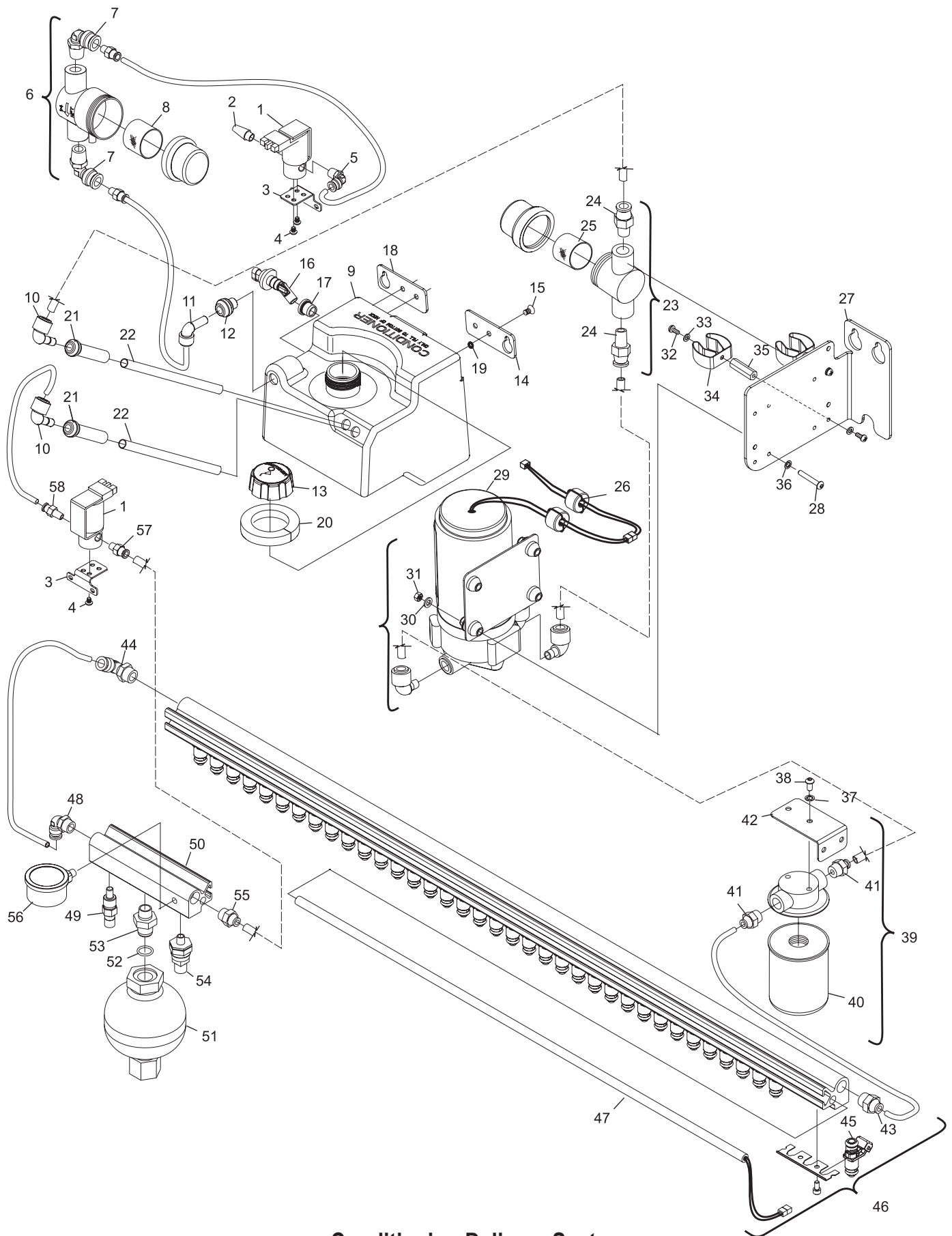

**Conditioning Delivery System**

**Index**

<b>No.</b>	<b>Part No.</b>	<b>Description</b>
1.	14-100057-000	Idler Pullet Mount
2.	14-100056-000	Idler Puller Tension Adjuster
3.	11-106554-009	Socket Head Shoulder Screw (5/16-18 x 3/8 Dia. x 1")
4.	11-655032-000	Shaft Collar (3/8")
5.	14-100314-000	Pivot Rod Assembly (long)
6.	14-100311-000	Shaft Coupler (3/8" to 3/8")
7.	14-100315-000	Pivot Rod Assembly (short)
8.	14-100045-000	Up/Down Linkage
9.	11-106550-009	Socket Head Shoulder Screw (5/16-18 x 3/8" Dia. x 3/8")
10.	11-191752-000	Nylon Washer (.390 I.D. x .75 O.D. x .062)
11.	11-125202-015	Nut (5/16-18)
12.	14-100044-000	Flange Mount Bearing Assembly
13.	14-100042-000	Gear belt Pully/Short Shaft Assembly
14.	14-100352-000	Buffer Up/Down Motor Assembly
15.	14-100348-000	Buffer Up/Down Motor Cable Assembly
16.	14-100350-000	Buffer up/Down Motor Mount Bracket
17.	11-616026-000	Switch
18.	11-006010-000	Button Head Cap Screw (#4-40 x 1")
19.	11-199000-015	Internal Tooth Lock Washer (#4)
20.	14-100349-000	Gear Motor
21.	11-006121-000	Button Head Socket Cap Screw (#10-32 x 3/4")
22.	11-199003-015	Internal Tooth (#10) Lockwasher
23.	14-100258-000	Up/Down Switch Cable Assembly
24.	11-105454-000	Set Screw (1/4-28 x 3/8")
25.	14-100227-000	Up/Down Cam
26.	14-100043-000	Buffer Brush Assembly
27.	11-601010-000	Roller Chain
28.	14-100070-000	Dispersion Roller Assembly
29.	14-100111-000	Dispersion Roller Idler Pulley
30.	14-100202-000	Grease Fitting
31.	11-491102-000	Sprocket (23 tooth)
32.	11-105457-000	Set Screw (1/4-20 x 3/8")
33.	11-006125-000	Hex Head Socket Screw (#10-32 x 1")
34.	11-199003-015	Internal Tooth Lockwasher (#10)
35.	14-100169-000	Dispersion Motor Mount Bracket
36.	14-100269-115	Motor w/Connections Assembly (115VAC)
	14-100269-230	Motor w/Connections Assembly (230VAC)
37.	11-171504-000	Nut (1/4-20)
38.	11-010783-000	Hex Head Serrated Flange Screw (5/16-18 x 3/4")
39.	11-171501-000	Nut (5/16-18)
40.	14-100434-000	Buffer Brush Shield w/Felt Assembly
41.	11-655022-000	Gearbelt (24")
42.	14-100016-000	Buffer Drive Motor (1/3 HP)
43.	14-100055-000	Gear belt Pulley
44.	14-100273-000	Buffer Brush Motor Cable Assembly
45.	14-100567-000	Buffer Belt Tensioner Pulley
46.	11-600010-000	Chain Link
47.	11-696736-000	Terminal - Pin
48.	11-696701-000	Connector Housing
49.	14-100433-000	Buffer Shield Felt
50.	14-100426-000	Buffer Shield Guard
51.	14-100427-000	Buffer Shield Drip Foam
52.	*14-100557-000	Buffer Shield V-Shape Drip Foam

\* *Not Illustrated*

## Conditioner Buffing System

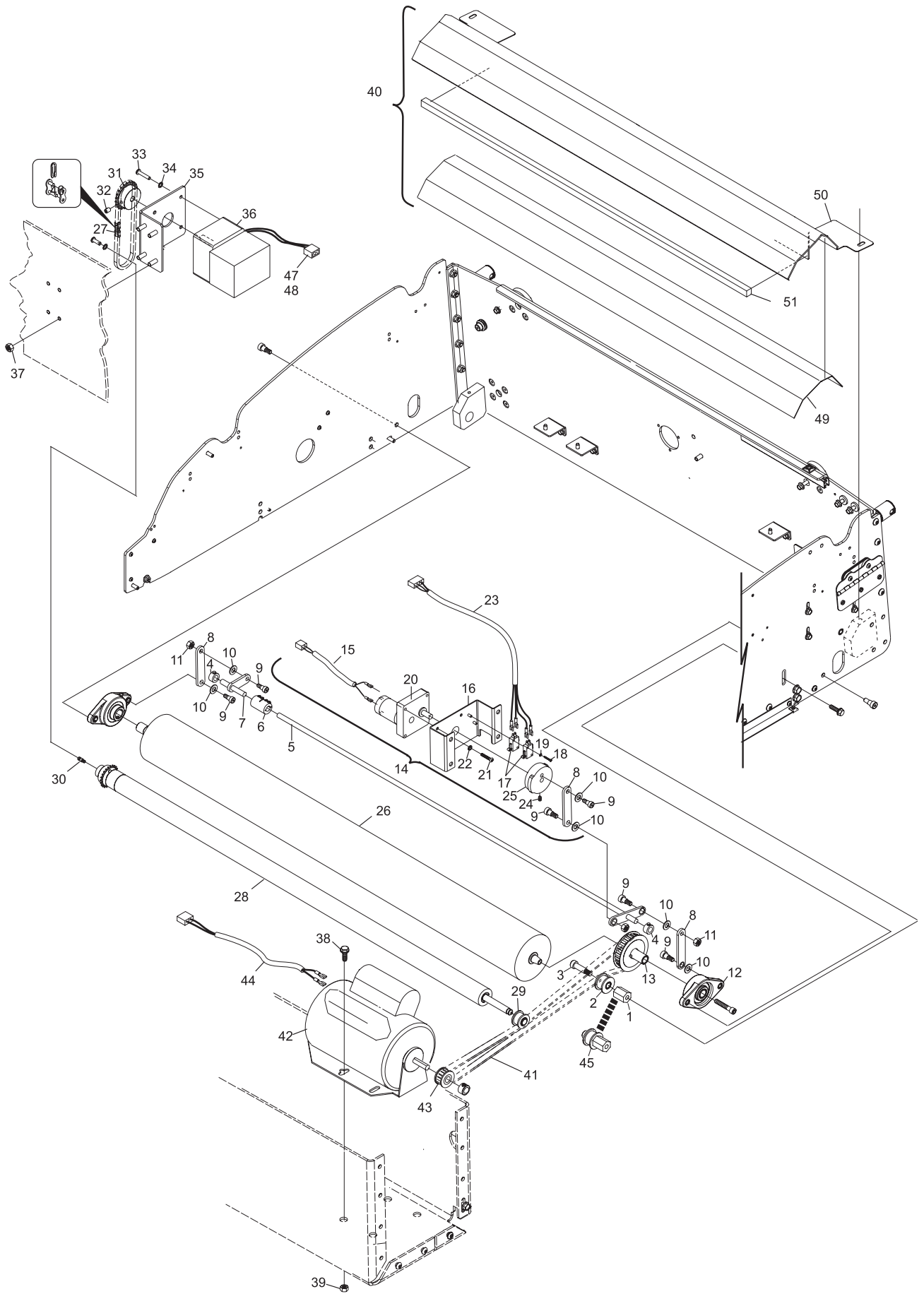

**Conditioner Buffing System**

*Intentionally Blank Page*

Section D

**Cover & Handle System**

No.	Index Part No.	Description
1.	14-100571-000	Side Cover (right-hand)
2.	14-100569-000	Rear Cover
3.	11-192028-000	Spacer(nylon)
4.	14-100572-000	Top Cover Assembly (right-hand)
5.	11-006127-000	Button Head Cap Screw (#10-32 x 1-1/4")
6.	14-100312-000	Hinge Nut Plate
7.	14-100373-000	Shim
8.	11-210008-000	Gas Spring (10lb. force)
9.	14-100573-000	Top Cover Assembly (left-hand)
10.	14-100570-000	Side Cover (left-hand)

## Hood System

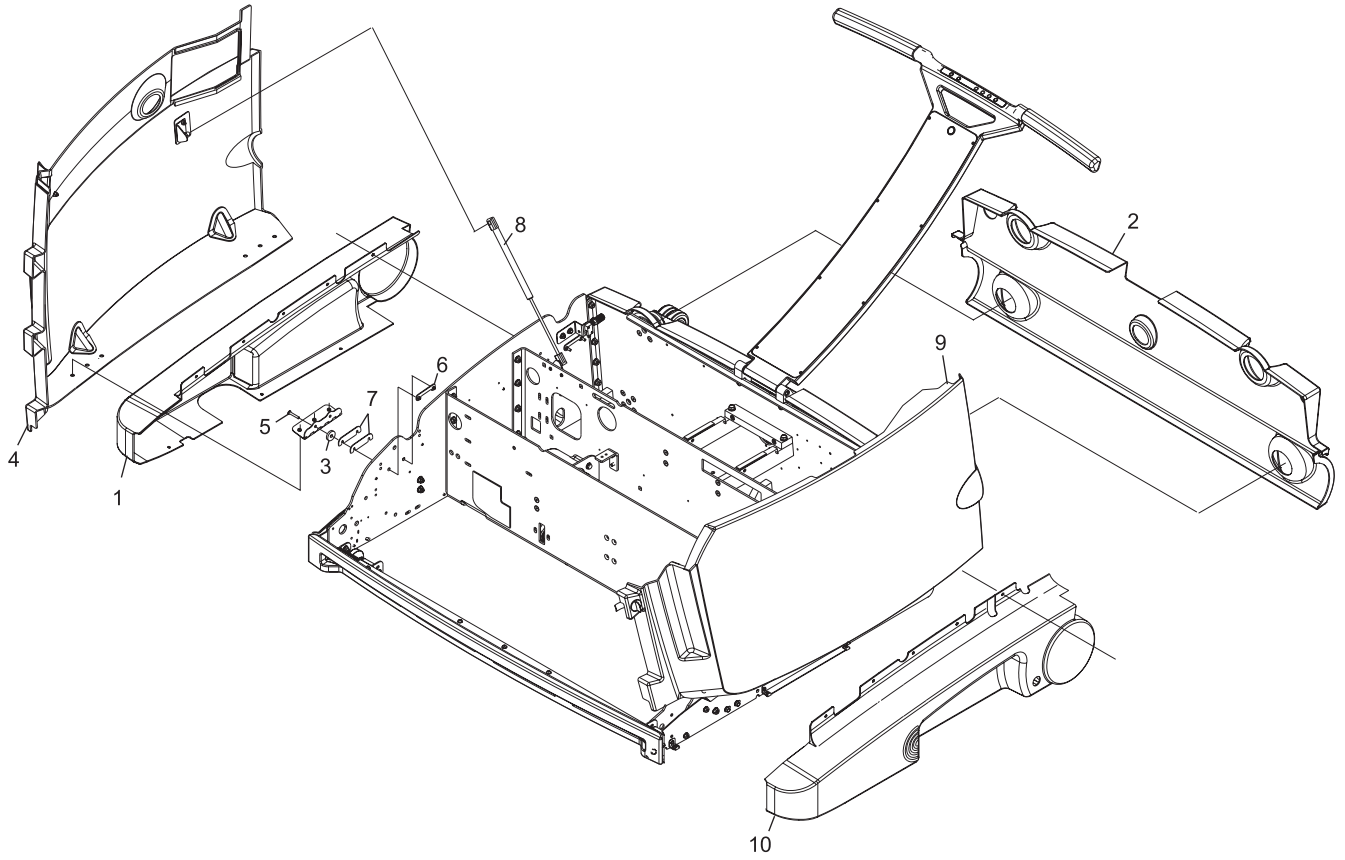

## Hood System

**Index**

<b>No.</b>	<b>Part No.</b>	<b>Description</b>
1.	11-010789-000	Hex Head Serrated Flange Screw (5/16-18 x 1-1/4")
2.	14-100132-000	Handle w/Cover plate Assembly
3.	14-100134-002	Handle Hinge Bracket (left hand)
4.	11-010783-000	Hex Head Serrated Flange Screw (5/16-18 x 3/4")
5.	14-100543-000	Over Travel Block Assembly
6.	14-100142-000	Over Travel Block (lower)
7.	11-005353-015	Socket Head Cap Screw (3/8-16 x 2-1/4")
8.	14-100141-000	Over Travel Block (upper)
9.	11-581050-000	Spring
10.	14-100393-000	Handle Keypad Assembly
11.	14-100376-000	Handle Cover Plate
12.	11-637202-000	Magnet
13.	11-004996-000	Socket Head Cap Screw (M4 x 12 mm)
14.	14-100012-002	Handle Grip (left hand)
15.	14-100012-001	Handle Grip (right hand)
16.	14-100186-091	Handle Keypad to GUI Cable Assembly
17.	84-200297-000	Double Sided Adhesive Foam Tape
18.	14-100136-000	Handle Keypad Backer Plate
19.	14-100137-000	Handle Keypad GUI
20.	14-100134-001	Handle Hinge Bracket (right hand)
21.	11-084222-015	Flat Head Self Tapping Screw (#4-40 x 1/4")
22.	14-100415-000	Raised Brunswick Decal
23.	11-005272-015	Socket Head Cap Screw (5/16-18 x 2")

**Handle System**



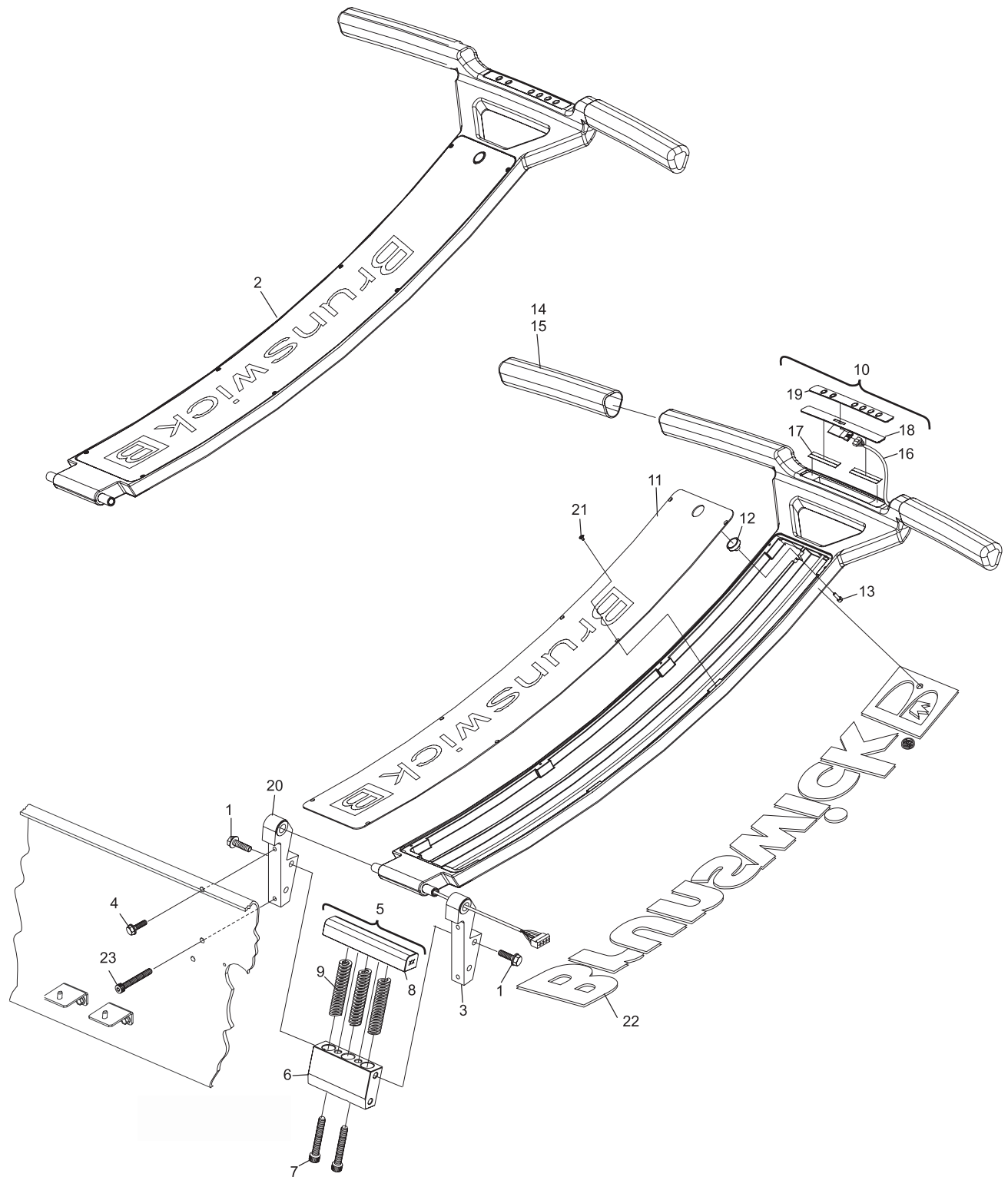

## Handle System

*Intentionally Blank Page*

Section E

**Electrical System**

<b>Index No.</b>	<b>Part No.</b>	<b>Description</b>
1.	11-007180-015	Flat Head Socket Cap Screw (1/4-20 x 5/8")
2.	14-100441-001	GUI Support Assembly (left hand)
3.	14-100441-002	GUI Support Assembly (right hand)
4.	14-100357-000	GUI Keypad
5.	14-100176-000	GUI LCD
6.	11-176-005015	Keys Nut (#6-32)
7.	14-100185-000	Com 2 Ribbon Cable Assembly
8.	14-100177-000	UPS PCB
9.	14-100178-406	Viper PC104 PCB
10.	14-100293-000	GUI Power/Communications Cable Assembly
11.	14-100362-400	Graphics User Interface

## Graphical User Interface

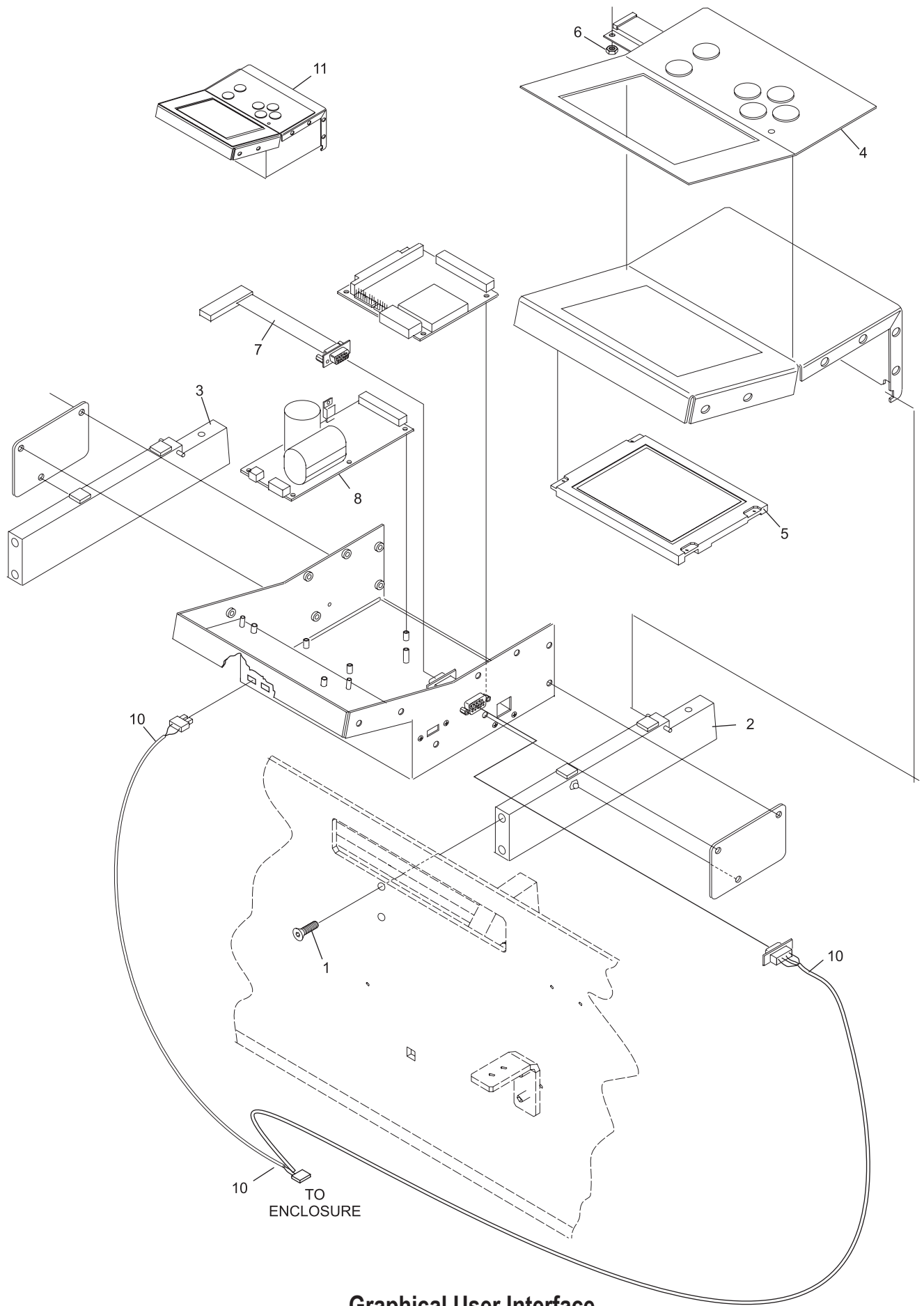

**Graphical User Interface**

<b>Index No.</b>	<b>Part No.</b>	<b>Description</b>
1.	14-100162-000	Cord Kill Switch Assembly
2.	11-616031-000	Switch
3.	11-006007-000	Button Head Cap Screw (#4-40 x 5/8")
4.	11-170000-015	Nut (#4-40)
5.	14-100161-000	Switch Bracket
6.	14-100267-000	Cord Kill Stud Assembly
7.	14-100159-000	Cord Kill Switch
8.	11-530031-015	Retaining Ring (external)
9.	11-581012-000	Spring
10.	14-100160-000	Cord Kill Switch Sleeve
11.	14-100209-000	Isolation Transformer
12.	14-100154-115	Electrical Control Enclosure Assembly (115VAC)
	14-100154-230	Electrical Control Enclosure Assembly (230VAC)
13.	11-021022-001	Pan Head C.R. Screw w/Lockwasher (#6-32 x 3/8")
14.	14-100498-000	Emergency Stop Switch Assembly
15.	14-100085-000	Power Switch to Circuit Breaker Wire Assembly
16.	14-100418-000	Motor Control PCB Assembly
17.	14-100466-400	Controller PCB Assembly
18.	14-100414-000	Injector Drive PCB Assembly
19.	14-100285-115	Regenerative Drive (115V)
	14-100285-230	Regenerative Drive (230V)
20.	11-190004-015	Flat Washer (#8)
21.	11-176005-015	Hex Nut w/Lockwasher (#6-32)
22.	11-672524-115	Relay General Purpose (100/120 AC)
	11-672524-230	Relay General Purpose (200/240 AC)
23.	14-100157-000	Power Supply
24.	14-100146-000	Cautions and Warnings Decal
25.	14-100240-000	Input Power to Terminal Block Cable Assembly
26.	14-100247-000	Power Switch to Circuit Breaker Cable Assembly
27.	14-100245-000	Power Motor PCB to Controller Cable Assembly
28.	14-100264-000	Power Supply to Motor PCB Cable Assembly
29.	11-616030-115	Circuit Breaker (16A, 32VDC, 250VAC)
	11-616030-230	Circuit Breaker (10A, 230 VAC)
30.	11-616029-115	Hi-Inrush Switch (115V)
	11-616029-230	Hi-Inrush Switch (230V)
31.	11-900717-000	"Emergency Stop" Decal

## Electrical Enclosure

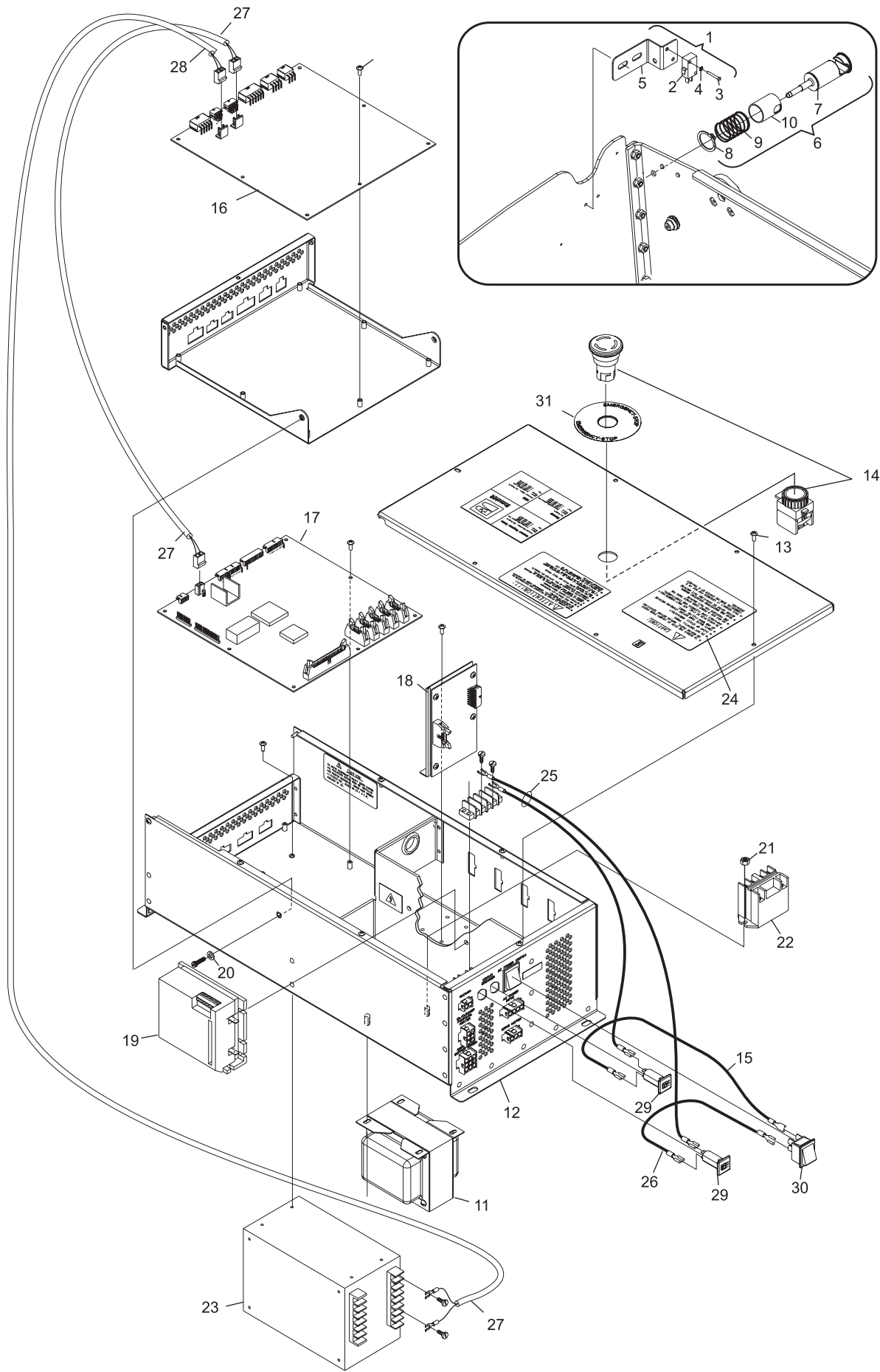

**Electrical Enclosure**

**Index**

<b>No.</b>	<b>Part No.</b>	<b>Description</b>
1.	14-100238-001	Injectors 1-8 Cable Assembly
2.	14-100238-002	Injectors 9-16 Cable Assembly
3.	14-100238-003	Injectors 17-24 Cable Assembly
4.	14-100238-004	Injectors 25-32 Cable Assembly
5.	14-100238-005	Injectors 33-39 Cable Assembly
6.	14-100232-000	Buffer Squeegee Up/Down Cable Assembly
7.	14-100490-000	Motor PCB to Valves Cable Assembly
8.	14-100234-000	Duster Cloth Rake Up Cable Assembly

**Power Cables for DC Output**



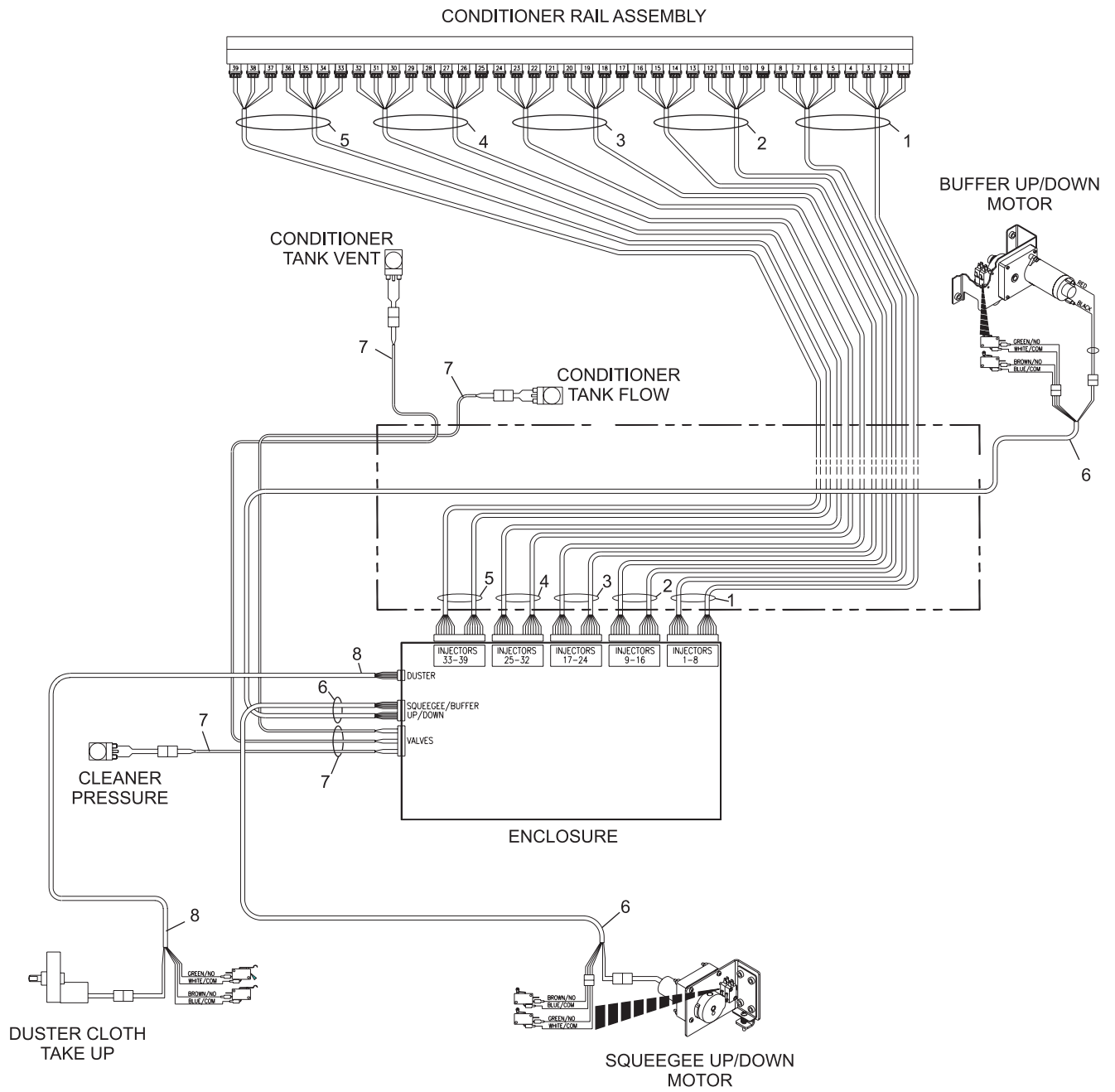

### Power Cables for DC Output

<b>Index No.</b>	<b>Part No.</b>	<b>Description</b>
1.	14-100492-000	Pumps Heater Rail Cable Assembly
2.	14-100230-000	Buffer Brush Dispersion Motor Cable Assembly
3.	14-100260-000	Vacuum Cable Assembly
4.	14-100402-230	Power Cord Input End (230VAC)
	14-100497-115	Power Cord Input Cable Assembly (115VAC)

## Power Cables for AC Output

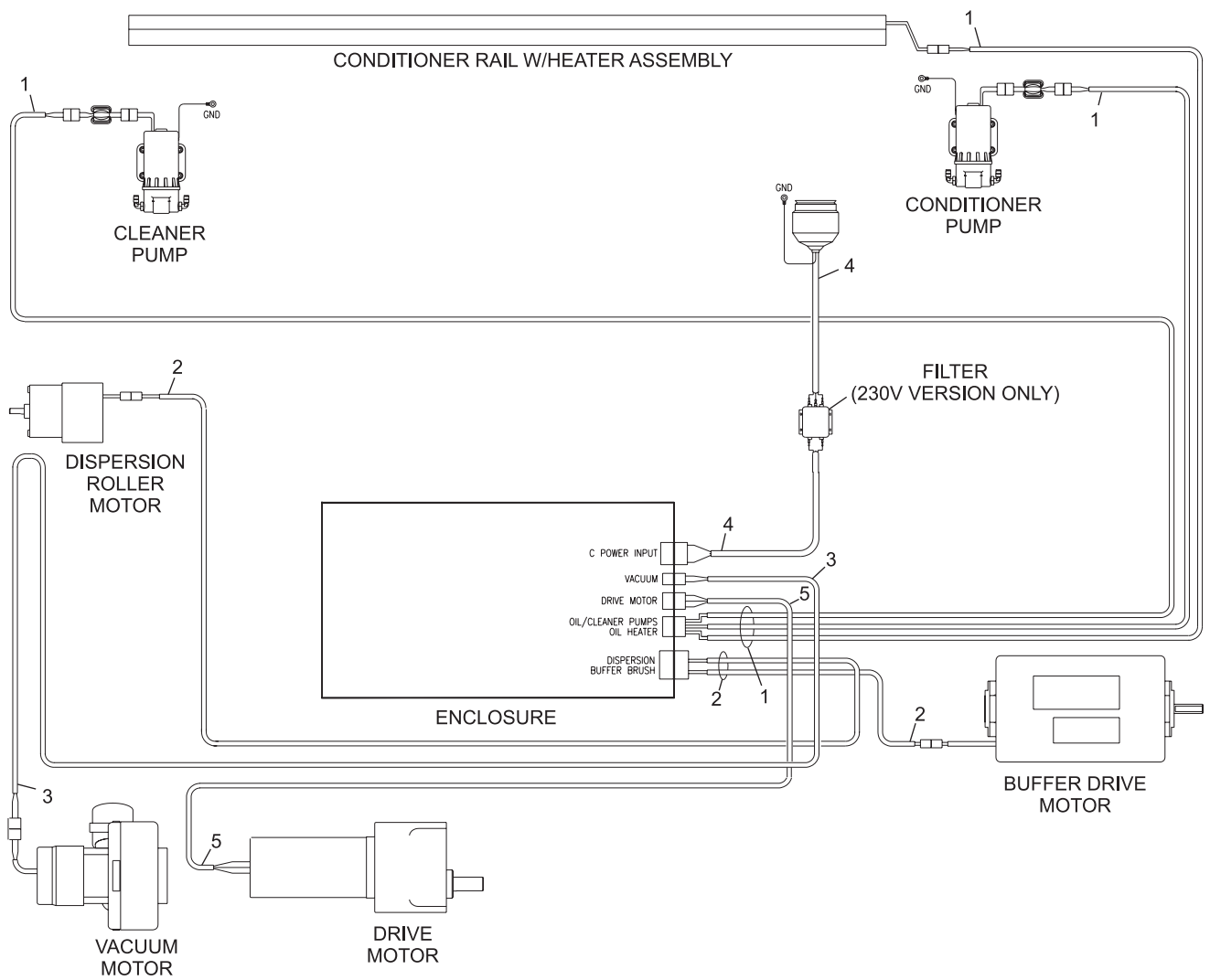

**Power Cables for AC Output**

**Index**

<b>No.</b>	<b>Part No.</b>	<b>Description</b>
1.	14-100255-000	Cord/Speed/Tank Sensors Cable Assembly
2.	14-100491-000	Controller to Sensors

**Power Cables for Sensors**

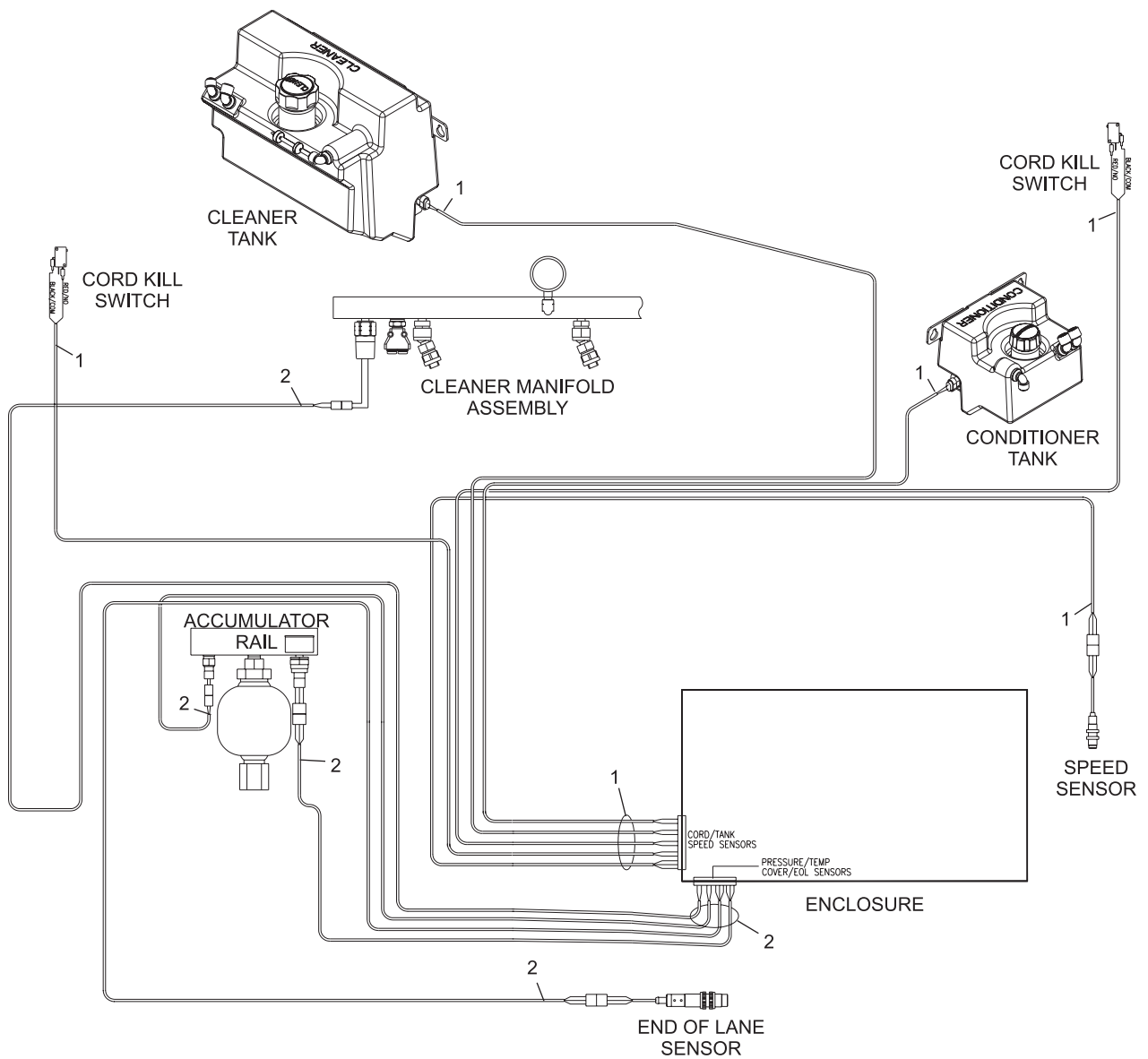

## Power Cables for Sensors

**Index**

<b>No.</b>	<b>Part No.</b>	<b>Description</b>
1.	11-696744-000	Twist-Lock Connector (125V)
	11-696749-000	Twist-Lock Connector (250V)
2.	11-603135-000	Split Ring (1.159 I.D.)
3.	11-617079-000	Heat Shrink (6")
4.	11-617076-001	Braided Sleeving
5.	11-617077-002	Heat Shrink (40")

**Power Cord**

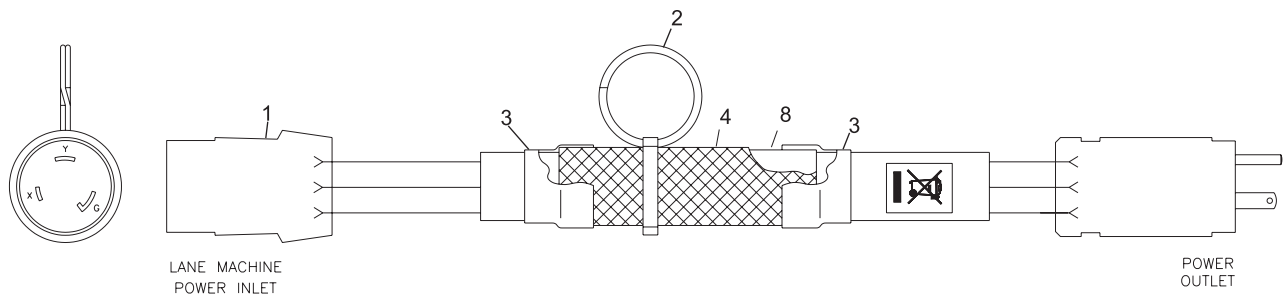

## Power Cord

*Intentionally Blank Page*



Section F

**Miscellaneous**

**Index**

<b>No.</b>	<b>Part No.</b>	<b>Description</b>
1.	R8020009400	A22 1st Yr Tune-up Kit (V2.0-115V)
2.	R8020009200	A22 2nd Yr Tune-up Kit (V2.0-115V)
3.	R8020009500	A22 1st Yr Tune-up Kit (V2.0-230V)
4.	R8020009300	A22 2nd Yr Tune-up Kit (V2.0-230V)

**Tune Up Kits**

**Index**

<b>No.</b>	<b>Part No.</b>	<b>Description</b>
1.	14-860214-000	Pkg-Fuse, 4.0A, 250V Slow 5 mm x 20 mm (Traction Drive Motor)
2.	14-860215-000	Pkg- Fuse, 3.15A 250V Slow 5 mm x 20 mm (Conditioner heater, spare)
3.	14-860216-000	Pkg- Fuse, 10A, 250V Slow, 5 mm x 20 mm (Vacuum Motor)
4.	14-860217-000	Pkg-Fuse, 8.0A, 250V Slow, 5 mm x 20 mm (Buffer Drive Motor Starter)
5.	14-860218-000	Pkg- Fuse 6.3A, 250V Slow, 5 mm x 20 mm (Buffer Drive Motor)
6.	14-860219-000	Pkg-Fuse, 1.25A, 250V Slow, 5 mm x 20 mm (Conditioner and Cleaner Pumps, Dispersion Roller Motor)
7.	11-112134-000	Tool - Dual Fuse Remover

**Fuses**

**Index**

<b>No.</b>	<b>Part No.</b>	<b>Description</b>
1.	57-901001-000	Uni-Mate Extraction Tool (.093)
2.	57-900102-000	Molex Round Extractor (.062)
3.	57-900104-000	AMP Extractor #18040301 (1 Round)
4.	57-900112-000	Molex Mini-Fit Extraction Tool
5.	57-901002-000	Molex Micro-Fit 3.0 Extraction Tool

**Extraction Tools**

**Index**

<b>No.</b>	<b>Part No.</b>	<b>Description</b>
1.	11-696736-000	Pins (Uni-Mate)
2.	11-696737-000	Sockets (Uni-Mate)
3.	11-680302-000	Pkg. of 10 Pins (.062)
4.	11-680301-000	Pkg. of 20 Sockets (.062)
5.	11-680316-000	Sockets (Micro-Fit 3.0)
6.	11-692091-000	Pkg of 10 Sockets (Mini-Fit Jr)
7.	11-612153-000	Fast-ons (.250)
8.	11-680328-000	Terminals (.156 kk )
9.	57-900103-000	Crimp Service Tool
10.	11-680309-000	Brass Terminal Loose (.062)

**Pins & Sockets**

**Index**

<b>No.</b>	<b>Part No.</b>	<b>Description</b>
1.	14-100092-000	Gage (Depth, Squeegee/Buffer Brush)
2.	11-112132-000	Long T-Handle Allen Wrench (1/4")
3.	11-112133-000	Screwdriver (#2 Phillips 10" Shank)
4.	11-112135-000	Open End Wrench (11/32, 12Pt 4.84" L)
5.	11-676691-000	Loctite Plastic Pipe Sealant (80726)
6.	11-676692-000	Loctite Metal Pipe (#567)
7.	11-676693-000	Loctite Threadlocker (#262 Red 10MI)
8.	11-676696-000	Loctite Threadlocker (#242 Blue 10MI)
9.	11-900080-000	Teflon Tape (Tread Seal 1/2X260")

**Tools**

**Index**

<b>No.</b>	<b>Part No.</b>	<b>Description</b>
1.	11-655043-006	Tube (3/8" OD x .295 ID x 20')
2.	11-655013-010	Tube (1/4" OD x .170 ID x 20')
3.	11-655039-007	Cleaner Vent Tube (1/4" OD x 20')

**Tubing**

**Index**

<b>No.</b>	<b>Part No.</b>	<b>Description</b>
1.	14-860213-000	Pkg.- AC Input Adapter Kit G.U.I.
2.	14-860209-000	Pkg.- Cleaning Mixing Vessel No Spill

**Miscellaneous**