



Evo Flattop Grills

Designed & Built in the USA



SALES, SERVICE, INSTALLATIONS, PARTS
SINCE 1987

WWW.ALPINECANADA.COM

604-980-8889 TOLLFREE 1-833-980-8889

SALES@ALPINECANADA.COM

Unforgettable Gatherings

Gather around Evo and celebrate the simple pleasure of sharing a meal with family and friends.

At Evo, bringing people together around food is our passion. It's also what inspired us to design and build the most versatile grill that lets people share the joy of cooking.

With its circular flattop cooking surface, Evo lets you prepare virtually any cuisine from any angle. By cooking foods directly on the cook surface, you can sear, sauté, grill, toast and stir-fry. Indirectly, you can use pots or pans to boil, braise, poach or steam.

evo[®]



Affinity 30G

The Evo Affinity 30G Cooktop is designed for built-in installation in large custom outdoor Kitchens.



Affinity 25G

The Evo Affinity 25G Cooktop is designed for built-in installation in small custom outdoor Kitchens.



Professional Wheeled Cart

The Evo Professional Wheeled Cart is designed for outdoor entertaining on your backyard deck or patio.



Professional Tabletop

The Evo Professional Tabletop is designed for outdoor entertaining at home or on the road.



Circular black oil-seasoned cooking surface.



Two knobs on the control panel adjust the burners.



Dual independently-controlled burners produces edge-to-edge even heat ranging from 225°F to 550°F (107°C to 288°C).



A stainless lid is included that converts the flattop grill into an oven for baking, roasting, or smoking.

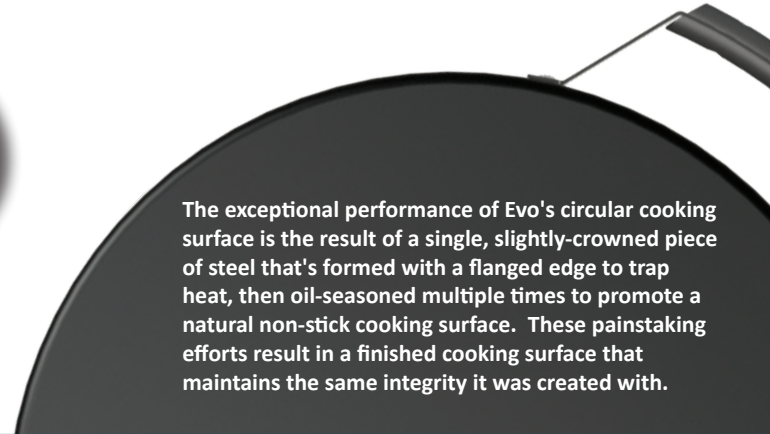

The exceptional performance of Evo's circular cooking surface is the result of a single, slightly-crowned piece of steel that's formed with a flanged edge to trap heat, then oil-seasoned multiple times to promote a natural non-stick cooking surface. These painstaking efforts result in a finished cooking surface that maintains the same integrity it was created with.

Quality Craftsmanship - Built to Last

Affinity 30G

Drop-In Gas Cooktop

for large custom outdoor kitchens
Model# SA-10-0055



DUAL GAS BURNERS

Independently-controlled burners provide two heat zones.



TRIM KIT

Stainless steel square insert for easy installation into counter (optional).

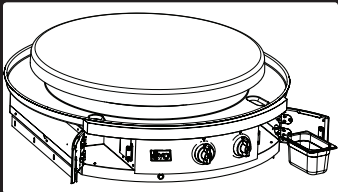

SPILLOVER TRAYS

Remove from doors at each right and left side of the control panel.

Adjustable Vent

exhausts steam and vapors from under lid

Stainless Steel Drip Pan

surrounds cook surface to contain spillovers

Heavy Gauge 304

Stainless Steel Construction

Removable Spillover Trays

concealed behind doors at right and left side of control panel; removable, dishwasher safe

Electronic Starter

provides one-touch ignition to both burners



Lid lets you roast, steam, warm, or smoke foods

Cooking Surface solid plate black oil-seasoned steel that's 30 inches in diameter, 707 sq. inches total. Dual burners provide variable temperatures from 225°F to 550°F, with 37,638 BTUs for LP and 36,267 BTUs for NG

Flame Portals located just below cook surface provide a convenient view of the burners

Inner and Outer Burner Control Knobs command variable temperatures across two circular heat zones for edge-to-edge even heat

The Affinity 30G installs to a counter surface leaving only the cooking surface, drip pan and control panel exposed. Minimum 3/8" clearance to combustible surfaces allows installation to wood, rock, concrete and tiled counter surfaces.

For Product Specifications
SALES@ALPINECANADA.COM

evo



Design the ultimate outdoor kitchen with an Evo Affinity 30G drop-in cooktop. Create the perfect outdoor entertaining space for your distinctive taste.

The Evo Affinity 30G Cooktop was built to be the centerpiece of your outdoor kitchen. With precise temperature control across dual gas burners and a highly capable cooking surface, the Affinity 30G is the perfect stage to entertain large or small parties.

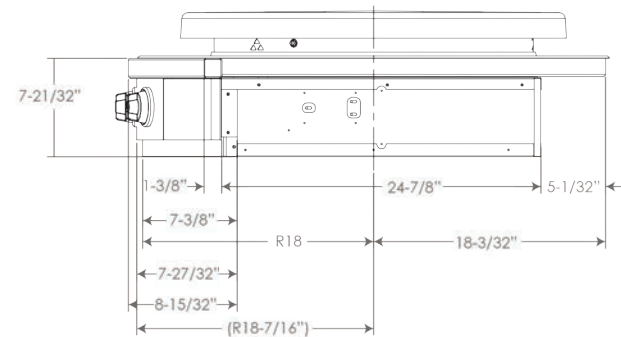
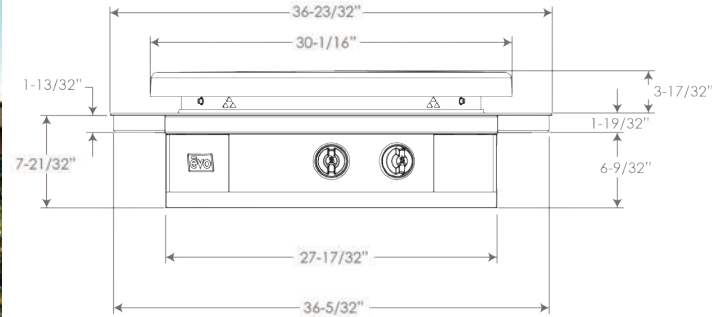

Affinity 25G

Drop-In Gas Cooktop

for small custom outdoor kitchens

Model# SA-10-0095



DUAL GAS BURNERS

Independently-controlled burners provide two heat zones.

Adjustable Vent

exhausts steam and vapors from under lid

Stainless Steel Drip Pan

surrounds cook surface to contain spillovers

Heavy Gauge 304

Stainless Steel Construction

Removable Spillover Trays

concealed behind doors at right and left side of control panel; removable, dishwasher safe

Electronic Starter

provides one-touch ignition to both burners



Lid lets you roast, steam, warm, or smoke foods

Cooking Surface solid plate black oil-seasoned steel that's 25 inches in diameter, 491 sq. inches total. Dual burners provide variable temperatures from 225°F to 525°F, with 27,600 BTUs for LP and 31,600 BTUs for NG

Flame Portals located just below cook surface provide a convenient view of the burners

Inner and Outer Burner Control Knobs command variable temperatures across two circular heat zones for edge-to-edge even heat

The Affinity 25G installs to a counter surface leaving only the cooking surface, drip pan and control panel exposed. Minimum 3/8" clearance to combustible surfaces allows installation to wood, rock, concrete and tiled counter surfaces.



TRIM KIT

Stainless steel square insert for easy installation into counter (optional).

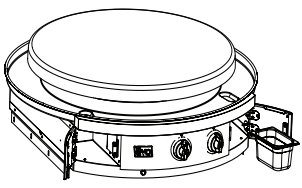

SPILLOVER TRAYS

Remove from doors at each right and left side of the control panel.

For Product Specifications:
SALES@ALPINECANADA.COM

ēvo



The Affinity 25G is perfect smaller outdoor kitchens or for cabinetry that can't support the depth of our Affinity 30G.

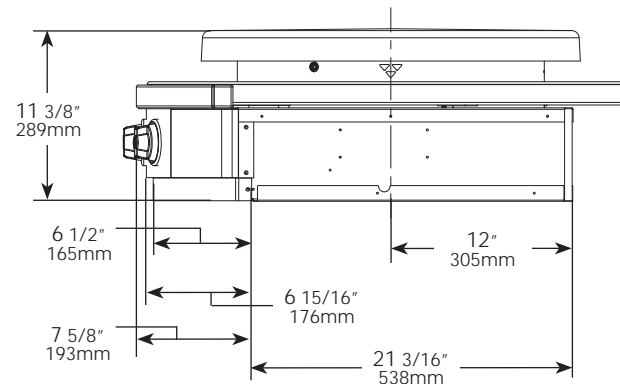
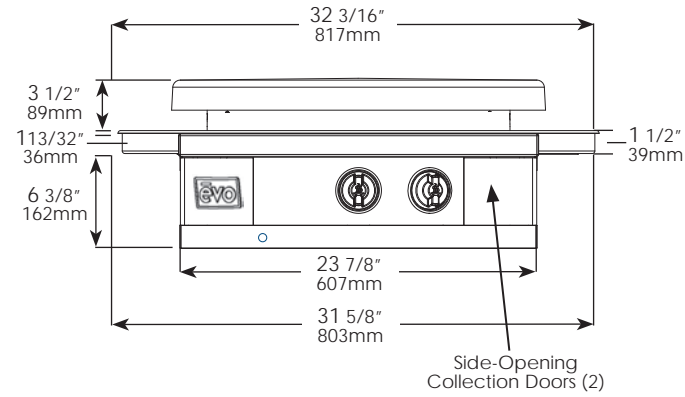

Professional Wheeled Cart

Flattop Gas Grill

Model# SA-10-0002



DUAL BURNERS

Independently-controlled burners provide two heat zones.

SPECIFICATIONS

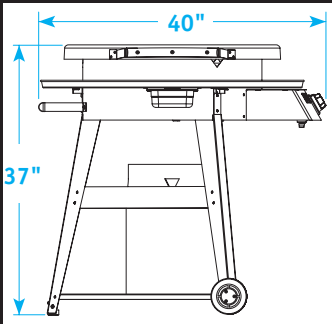

SIDE VIEW

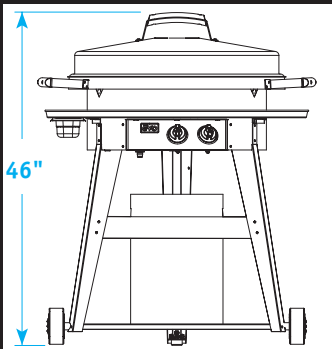

FRONT VIEW

Adjustable Vent

exhausts steam and vapors from under lid

Wide Grip Handles

makes moving the cook surface easy

Stainless Steel Drip Pan

surrounds cook surface to contain spillovers

Removable Spillover Tray

makes clean-up easy; stainless steel, dishwasher safe

Heavy Gauge Stainless Steel Construction Throughout

Electronic Starter

provides one-touch ignition to both burners

Propane Tank Shield

made of stainless steel; conceals a standard 20lb. LP tank

Heavy-Duty Rubber Wheels

easily navigate patios and decks



Lid lets you roast, steam, warm, or smoke foods

Cooking Surface solid plate black oil-seasoned steel that's 30 inches in diameter, 707 sq. inches total. Dual burners provide variable temperatures from 225°F to 550°F, with 48,000 BTUs

Flame Portals located just above the control panel provide a convenient view of the burners

Inner and Outer Burner Control Knobs command variable temperatures across two circular heat zones for edge-to-edge even heat

Stainless Steel Fasteners Throughout provide strength and lifetime rust-free quality

Removable Leg Brace provides access to LP tank for easy exchange (Propane models only)



For your backyard patio or deck. Gather around with family and friends for conversation and a great meal. Round up your neighbors and take the party outside!



LID HOOKS ON DRIP PAN



SKIRT HANDLE TO ROLL CART



EASY ACCESS TO GAS TANK

Professional Tabletop

Flattop Gas Grill

Model# SA-10-0021



DUAL BURNERS

Independently-controlled burners provide two heat zones.

SPECIFICATIONS

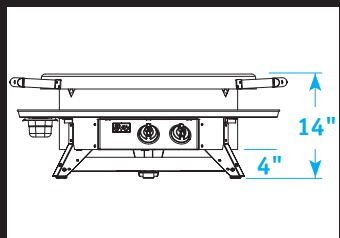

FRONT VIEW

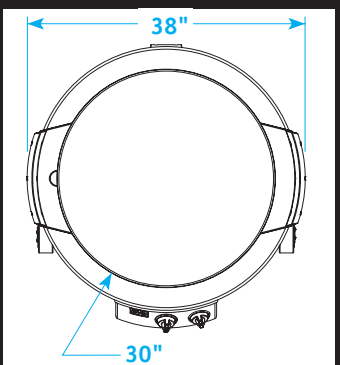

TOP VIEW

Adjustable Vent

exhausts steam and vapors from under lid

Wide Grip Handles

makes moving the cook surface easy

Stainless Steel Drip Pan

surrounds cook surface to contain spillovers

Removable Spillover Tray

makes clean-up easy; stainless steel, dishwasher safe

Heavy Gauge Stainless Steel Construction Throughout

Electronic Starter

provides one-touch ignition to both burners

Rubber Feet

to protect tabletop



Lid lets you roast, steam, warm, or smoke foods

Cooking Surface solid plate black oil-seasoned steel that's 30 inches in diameter, 707 sq. inches total. Dual burners provide variable temperatures from 225°F to 550°F, with 48,000 BTUs

Flame Portals located just above the control panel provide a convenient view of the burners

Inner and Outer Burner Control Knobs command variable temperatures across two circular heat zones for edge-to-edge even heat

Stainless Steel Fasteners Throughout provide strength and lifetime rust-free quality

For Product Specifications
SALES@ALPINECANADA.COM

evo



For home or on the road. Easy to setup on a picnic or banquet table. It's the perfect grill to take tailgating, camping, fishing, hunting or to a cookout!



LID HOOKS ON DRIP PAN



DRIP PAN FOR SPILLOVERS



TWO HEAT ZONES

Flattop Versatility

By cooking foods directly on the cook surface, you can sear, sauté, grill, toast and stir-fry. Indirectly, you can use pots or pans to boil, braise, poach or steam. With a few accessories you can create even more amazing meals. Enjoy your outdoor living area more by cooking every meal outside—breakfast, lunch, dinner and even dessert, on your Evo grill.



GRILL

Cook right on the flattop!



T
O
A
S
T



S
A
U
TÉ



SEAR



You get a caramelized, deep-brown sear (= flavor) with the Evo grill. When the oil starts to shimmer and smoke, you're ready to add the meat!

STIR FRY



Cooking rapidly over sizzling heat while stirring briskly.



STEAM



Squeeze water on food then cover with a lid to steam. Add more liquid and repeat until done.



ROAST



Turn your Evo grill into an oven with a roasting pan, rack and lid. Spatchcock turkey is one of our favorite roasted dishes.

SMOKE



Place flavored wood chips or Evo "Smoke to Taste" canister on cooksurface, place food on a roasting rack and cover with a lid.

B
A
K
E



Place a rack underneath the food and cover with the Evo lid.



Endless Menu Possibilities



Make Breakfast,
Lunch or Dinner

Steaks, Burgers, Grilled Sandwiches, Flatbread Pizza, Stir-Fry. Pancakes, Scrambled Eggs, Omelettes, Huévos Rancheros, Bananas Foster, Fajitas, Pita Bread, Grilled Caesar Salad, Chicken Satays, Pork Chops, Corn Cakes, Quesadillas, Fried Rice, Bratwurst, Crepes, Crab Cakes, Scallops, Shrimp, Fish Fillets, Seafood Paella, Yakisoba Noodles, Cedar Plank Salmon, Lamb Kabobs, Polish Sausage, Handmade Tortillas, Potato Pancakes, Injera, Crostini, Philly Cheese Steak, Ratatouille, Mixed Grill, Spatchcock Turkey, Tacos, Burritos, Bacon, Fried Potatoes.....

www.alpinecanada.com



PRODUCTS

The information you need on Evo appliances.



SUPPORT

Visit us online, or call toll-free 1-833-980-888 or direct 604-980-8889.



ACCESSORIES

We carry steamer lids, roasting racks, vinyl covers, cooking or cleaning supplies, and more.



CONTACT

Call toll-free 1-833-980-8889, or direct 604-980-8889, or email at sales@alpinecanada.com

**Appetizers
& Dessert too!**

Indoor Models

Chef performance for your home kitchen

Evo cooktops are the ultimate social cooking appliance for any indoor kitchen. The unique style captures attention, while the highly functional design encourages participation, all to the delight of your onlooking audience.



Affinity 25E Model# SA-10-0061-EL

The Affinity 25E is an electric cooktop designed for indoor kitchens. It features a 25" diameter black seasoned cooking surface with an independently-controlled heater providing two circular heat zones. Temperatures are variable from 150°F to 525°F (66°C to 274°C).

Operating on 208V-230V, the Affinity 25E Cooktop is an ideal solution for creating a social cooking space in your indoor kitchen.



Affinity 30Gp Model# SA-10-0075

The Affinity 30Gp is a gas cooktop with standing pilot light designed for indoor kitchens. It features a 30" diameter black seasoned cooking surface with two independently-controlled gas burners and two circular heat zones. Temperatures are variable from 225°F to 525°F (121°C to 274°C. 37,638 BTUs for LP and 36,267 BTUs for NG.

The 30Gp is built to fit standard dimensions of residential kitchen countertops and islands. All controls are conveniently positioned up front on a curved control panel with an elevated cooking surface.

For Product Specifications
SALES@ALPINECANADA.COM

evo



Designed for built-in installation in residential indoor kitchen islands and counters.



All Evo Grills Are Shipped With:

- 1 Cook Surface Cleaning Kit - Includes Handle, Pad and Screen
- 2 Stainless Steel Spatulas
- 1 Stainless Steel Cook Surface Scraper
- 1 Evo Cookbook



evo

Part of **MIDDLEBY**

WWW.ALPIECANADA.COM
SALES@ALPIECANADA.COM

TOLLFREE 1-833-980-8889
DIRECT 604-980-8889

Evo is protected under U.S. Patents 6,189,530, 6,488,022, and 7,926,417 and U.S. Patents Pending.
Evo is a registered trademark of Evo, Incorporated. ©2023 All rights reserved.

