

# INVOLUTE POWERGEAR PVT. LTD.

ISO 9001-2008 Certified Systems

Manufacturers of Drives and Transmissions

## SHAFT MOUNTED GEAR UNIT

The **Shaft Mounted Gear Units** are compact in size, mounting directly onto the driven shaft thus eliminating the use of a foundation and couplings. The gears are helical, hardened and ground of suitable alloy steels. The gear box is suitable for both forward and reverse motion.

The torque arm anchors the gear box and provides an easy, quick method of adjustment of V-belts by means of a turnbuckle.

The gear boxes are currently manufactured in **twelve** sizes from **A** to **L** with nominal ratios of **5:1**, **13:1** & **20:1**. A wide range of final speed ratios may be achieved by use of pulley combinations.

The gear box has been redesigned by changing the tooth design to give higher power to weight ratios for the same size gear box.

**Shaft Mounted Taper Clamp Units** are available as keyless gear unit.

The taper clamps and the support bushes are manufactured in **stainless steels** to prevent fretting corrosion and easy removal. Various sizes of bores are available in the taper clamps providing a very easy method for mounting on different shaft sizes.

**Shaft Mounted Screw Conveyor Units** are available with tapered roller bearings on the output end to take in end thrusts.

The gear units are available in imperial bores and keyways.

CEMA flanges and drive shafts are available in various sizes.

### Three Stage Gear Unit

An additional 'gear-packet' for gear ratios upto 70:1

**Accessories:** Output hubs in stainless steels, labyrinth sealing, extraction collars, reducing bushes, safety covers, hydraulic motor mounts, motor mounts, anti roll back bush adapters and backstops are available.

**Specials:** Modifications to specific customer specifications, ratios, configurations and width of gear units.

Outline drawings are available in dxf format for CAD utilisation. It is also possible to print documents with technical data of the gear unit.

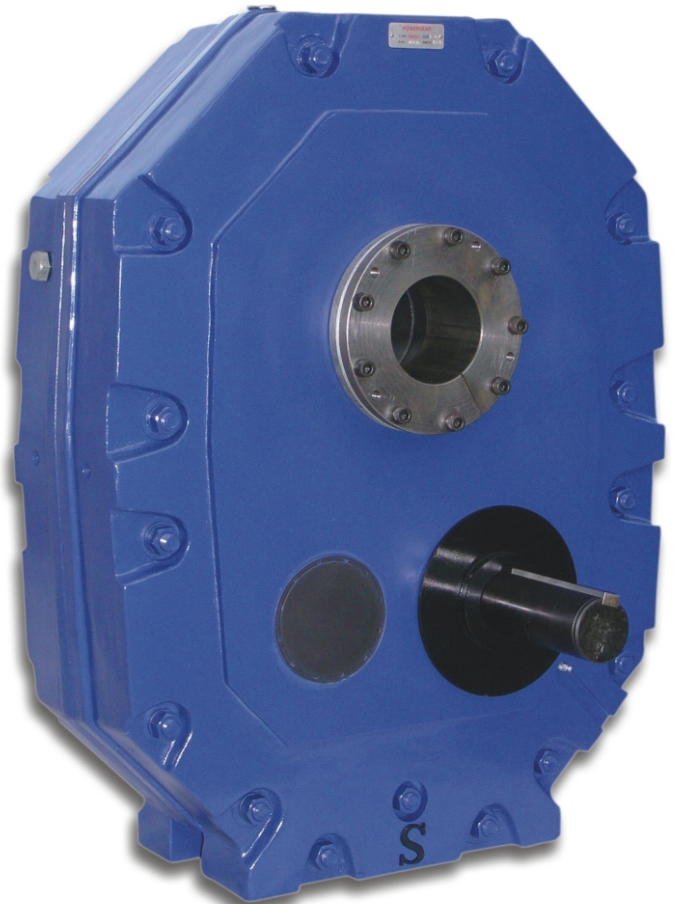

### Features

- \* Redesigned Gearing for Higher Power to Weight ratio
- \* Available with Keyed Bores or Taper Clamps
- \* Numerous Accessories
- \* Inter - changeable with Leading Brands
- \* ISO 9001 - 2008 Certified Systems
- \* All Gear Units Tested Prior to Dispatch
- \* 100% Inspection and Traceability of All Components



**POWERGEAR™**



**POULIGEAR.fr**

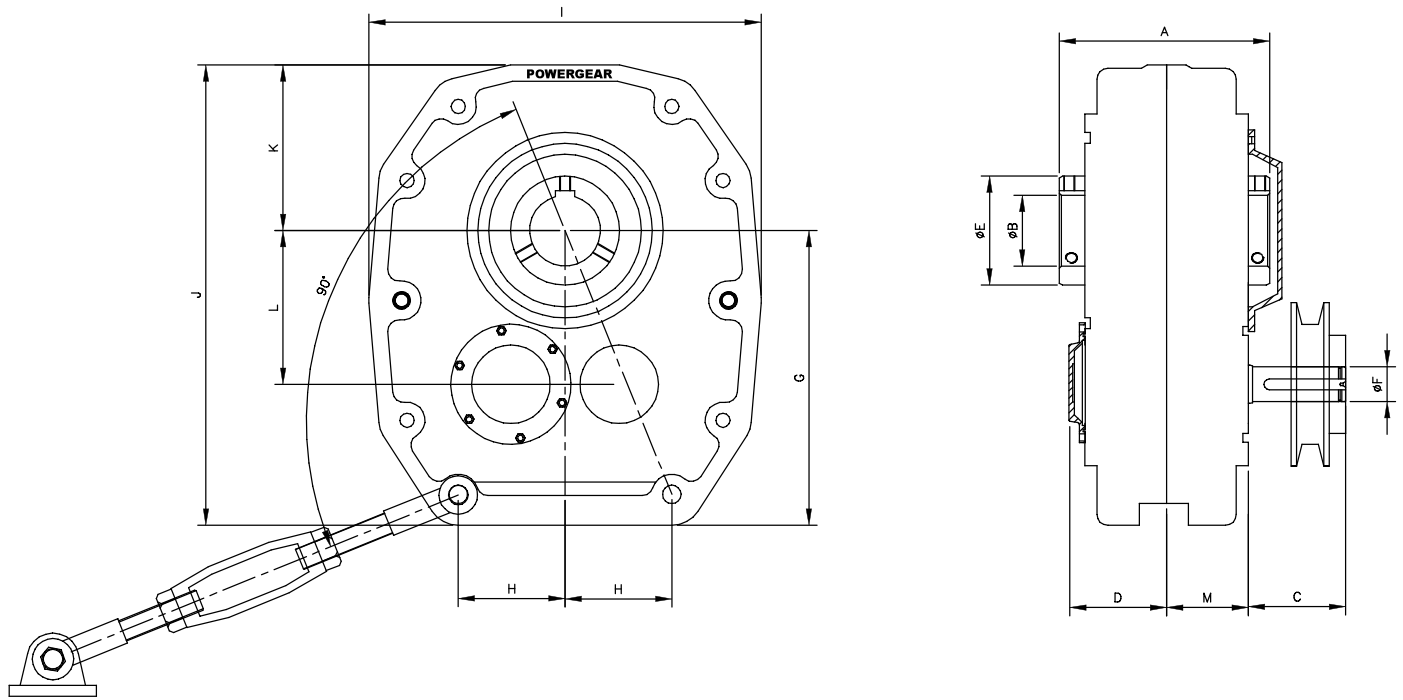

### Dimensions, Sizes A-L

Size	Mass Kg	A	KEYED HUB BORE ØB		C	D	ØE	ØF j 6	F KEY WAY	G	H	I	J	K	L	M
			STD	ALT												
A	13	124	30	-	50	50	45	14	5x3x40	128	51	163	215	75	67	40
B	15	134	30	40	63	59	55	19	6x3.5x50	131	55	185	225	80	75	52
C	22	142	40	50	72	65	65	22	6x3.5x56	155	60	220	270	95	90	55
D	32	152	50	55	77	68	75	25	8x4x63	188	75	260	325	120	110	61
E	45	170	55	65	85	76	85	28	8x4x70	221	90	280	370	130	125	66
F	75	189	65	75	90	87	100	32	10x5x70	242	98	360	430	158	140	75
Fx	78	222	65	75	91	102	100	32	10x5x70	242	98	360	430	158	140	90
G	100	215	75	85	105	110	110	42	12x5x90	282	110	370	485	180	155	86
H	150	245	85	100	115	115	130	48	14x5.5x100	330	90	440	561	195	190	95
J	280	260	100	120	135	120	150	55	16x6.0x100	425	100	545	702	255	255	105
Jx	310	280	100	120	118	130	150	55	16x6x100	424	100	545	702	255	255	115
S	350	305	120	125	170	154	160	60	18x7x150	517	90	622	804	288	267	122
K	600	350	150	---	195	180	200	65	18x7x175	668	240	710	1000	336	329	127
Ls	625	370	150	---	195	190	200	65	18x7x175	668	240	710	1000	336	329	137
L	650	400	150	---	195	200	200	65	18x7x175	668	240	710	1000	336	329	147

\*For Power Rating Refer Page 6 & 7

All dimensions in mm

Nominal Ratio	Exact Gear Ratios											
	B	C	D	E	F	G	H	J	S	K	L	
5:1	5.05	5.05	5.047	5.047	5.047	5.047	5.047	5.047	5.047	-	-	
13:1	13.984	13.596	13.589	13.589	13.589	13.589	13.589	13.589	13.544	13.26	13.26	
20:1	20.997	20.466	20.456	20.456	20.456	20.456	20.456	20.456	20.11	20.69	20.69	

## Shaft Mounted Screw Conveyor Gear Unit



- \* The gear units are available with tapered roller bearings on the output end to take in end thrusts.
- \* The gear units are available in Imperial bores and keyways.
- \* CEMA flanges and drive shafts are available in various sizes.

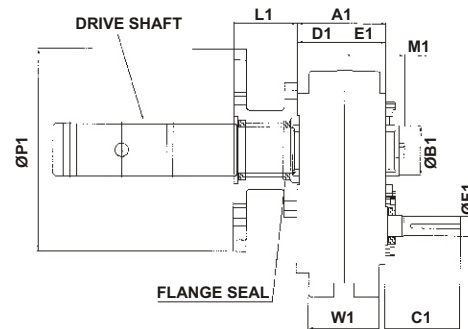
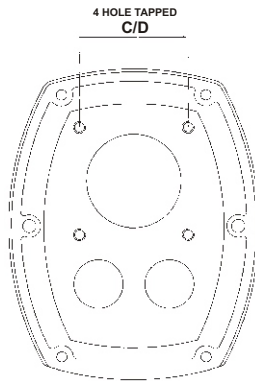

Size	A1	B1 HUB Ø	C1	D1	E1	F1 Ø	F1 KEY WAY	M1	W1	L1
B 1107	4.45	1 <sup>7</sup> / <sub>16</sub>	3.46	2.40	2.05	<sup>3</sup> / <sub>4</sub>	<sup>1</sup> / <sub>8</sub> x <sup>1</sup> / <sub>8</sub>	3.35	3.62	3.22
C 2115	4.65	1 <sup>15</sup> / <sub>16</sub>	3.66	2.48	2.17	<sup>15</sup> / <sub>16</sub>	<sup>3</sup> / <sub>16</sub> x <sup>3</sup> / <sub>16</sub>	3.54	3.82	3.56
D 3203	5.16	2 <sup>3</sup> / <sub>16</sub>	4.41	2.76	2.40	1 <sup>1</sup> / <sub>8</sub>	<sup>1</sup> / <sub>4</sub> x <sup>1</sup> / <sub>4</sub>	3.94	4.13	3.62
E 4207	5.67	2 <sup>7</sup> / <sub>16</sub>	5.70	3.07	2.60	1 <sup>1</sup> / <sub>8</sub>	<sup>1</sup> / <sub>4</sub> x <sup>1</sup> / <sub>4</sub>	4.11	4.64	4.00
F 5215	6.45	2 <sup>15</sup> / <sub>16</sub>	5.90	3.50	2.95	1 <sup>1</sup> / <sub>4</sub>	<sup>1</sup> / <sub>4</sub> x <sup>1</sup> / <sub>4</sub>	4.60	5.04	4.00
G 6307	7.54	3 <sup>7</sup> / <sub>16</sub>	6.14	4.00	3.54	1 <sup>3</sup> / <sub>4</sub>	<sup>3</sup> / <sub>8</sub> x <sup>3</sup> / <sub>8</sub>	5.15	5.98	5.50
H 7315	8.39	3 <sup>15</sup> / <sub>16</sub>	6.34	4.45	3.94	1 <sup>15</sup> / <sub>16</sub>	<sup>1</sup> / <sub>2</sub> x <sup>1</sup> / <sub>2</sub>	5.78	6.69	6.47
J 8407	8.73	4 <sup>7</sup> / <sub>16</sub>	7.28	4.60	4.13	2 <sup>1</sup> / <sub>4</sub>	<sup>1</sup> / <sub>2</sub> x <sup>1</sup> / <sub>2</sub>	6.10	7.71	6.47

all sizes in inches

## Flange And Drives Shaft Details

SIZE	C/D	4 HOLES	FLANGE SEAL SIZE			FLANGE Ø P1	DRIVE SHAFT
B 1107	3.225	<sup>3</sup> / <sub>8</sub> -16UNC	1.75	2.37	0.375	7	1 <sup>1</sup> / <sub>2</sub> , 2
C 2115	3.756	<sup>7</sup> / <sub>16</sub> -14UNC	2.25	3.00	0.375	11.5	1 <sup>1</sup> / <sub>2</sub> , 2, 2 <sup>7</sup> / <sub>16</sub> , 3
D 3203	4.508	<sup>1</sup> / <sub>2</sub> -13UNC	2.62	3.37	0.375	11.5	1 <sup>1</sup> / <sub>2</sub> , 2, 2 <sup>7</sup> / <sub>16</sub> , 3, 3 <sup>7</sup> / <sub>16</sub>
E 4207	5.038	<sup>1</sup> / <sub>2</sub> -13UNC	2.75	3.50	0.375	11.5	2, 2 <sup>7</sup> / <sub>16</sub> , 3, 3 <sup>7</sup> / <sub>16</sub>
F 5215	5.575	<sup>5</sup> / <sub>8</sub> -11UNC	3.25	4.00	0.375	11.5	2, 2 <sup>7</sup> / <sub>16</sub> , 3, 3 <sup>7</sup> / <sub>16</sub> , 3 <sup>15</sup> / <sub>16</sub>
G 6307	6.187	<sup>3</sup> / <sub>4</sub> -10UNC	3.87	4.87	0.500	14	2 <sup>7</sup> / <sub>16</sub> , 3, 3 <sup>7</sup> / <sub>16</sub> , 3 <sup>15</sup> / <sub>16</sub>
H 7315	6.541	<sup>3</sup> / <sub>4</sub> -10UNC	4.25	5.00	0.500	16	3, 3 <sup>7</sup> / <sub>16</sub> , 3, 3 <sup>15</sup> / <sub>16</sub> , 4 <sup>7</sup> / <sub>16</sub>
J 8407	7.425	<sup>3</sup> / <sub>4</sub> -10UNC	4.75	5.75	0.500	16	3 <sup>7</sup> / <sub>16</sub> , 3 <sup>15</sup> / <sub>16</sub> , 4 <sup>7</sup> / <sub>16</sub> , 4 <sup>15</sup> / <sub>16</sub>

all sizes in inches

## Shaft Mounted Taper Clamp Gear Unit

- \* Shaft Mounted Taper Clamp Units are available in sizes B-L
- \* Suitable for key-less applications on the output end of the gearbox
- \* Easy to install and even easier to remove
- \* High torque carrying capacity
- \* Bushes manufactured in stainless steel
- \* Perfect for prevention of fretting corrosion after years of use
- \* Bushes in Multiple bore sizes available in Metric and Imperial sizes
- \* Labyrinth Seals available for prevention of dust ingestion

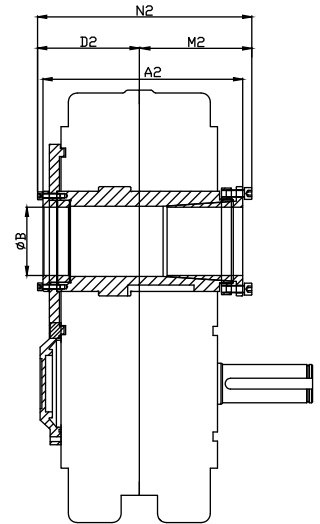

Size	A2	D2	M2	N2	Taper Clamp Bush Sizes, ØB		
					STD	ALT (mm)	Inches
B	150	78	84	162	30	25, 20	¾", 1"
C	155	81	87	168	40	35, 32, 30	1¼"
D	165	86	94	180	50	45, 42, 40, 38	1¾", 1½", 1¼"
E	180	92	102	194	55	50, 45, 42	2", 1¾", 1½"
F	200	101	115	216	65	60, 55, 50	2¼", 2"
G	219	112	123	235	75	70, 65, 60	2¾", 2½", 2¼"
H	237	120	134	254	85	80, 75, 70	3", 2¾", 2½"
J	258	130	145	275	100	95, 90	3½"
Jx	275	134	160	294			
S	302	155	162	317	120	110, 100, 90	4½", 4, 3½"
K	365	180	205	385	150	140, 125, 120	5", 4½", 4"
Ls	385	190	215	405			
L	405	200	225	425			

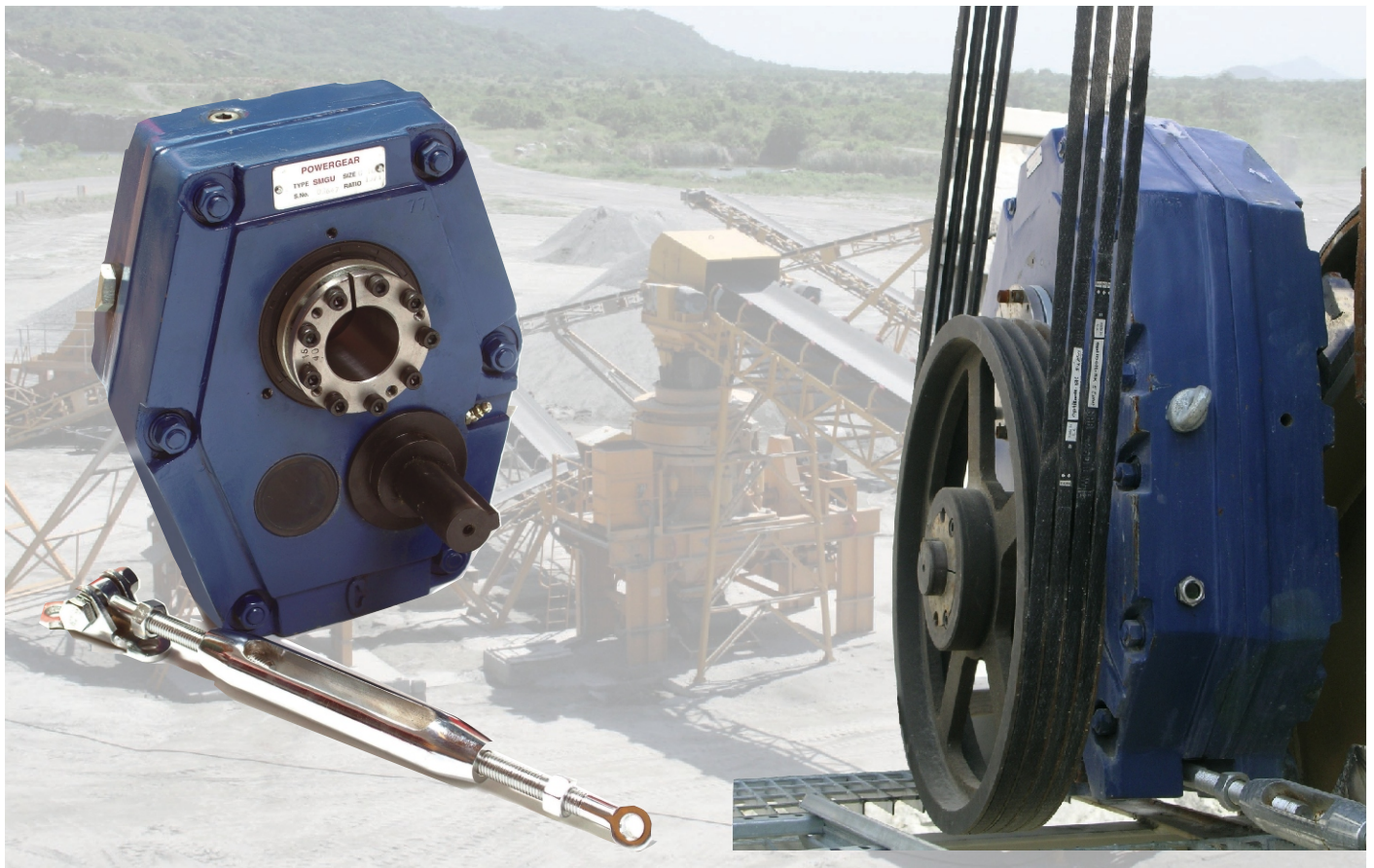

## T-Series Round Shaft Mounted Gear Unit



The **Round Shaft Mounted Gear Unit** is a versatile gearbox developed as an alternative to our shaft mounted gear units.

The speed reducer is compact in size mounting directly onto the driven shaft, thus eliminating the need of a foundation & coupling.

The torque arm anchors the speed reducer and provides easy & quick method of adjustment of V-belts by means of a turnbuckle.

The gearbox is available in **5 sizes of TD to TH** with a nominal ratios of **5:1, 13:1 and 20:1** with torque ratings upto 4500 Nm.

Reduction ratio of **15:1 or 30:1** is available on special request.

A wider range of final speed ratios may be achieved by use of pulley combinations. The gearbox is suitable for both forward and reverse motion.

### Accessories:

- \* **Anti-Roll Back Adapters / Backstops:** A simple accessory that prevents reversal of the speed reducer and is ideal for inclined conveyors.
- \* **Flanged Motor Mounts:** For directly coupling the electric motor to the gearbox.
- \* **Flanged Hydraulic Mounts:** For directly coupling hydraulic motor.



### Benefits:

- \* Hardened and Ground Gearing
- \* Compact and Low Cost
- \* High Efficiency of 96%
- \* Multiple Bore Sizes
- \* Backstop Provision in All Models
- \* Interchangeable with Leading Brands

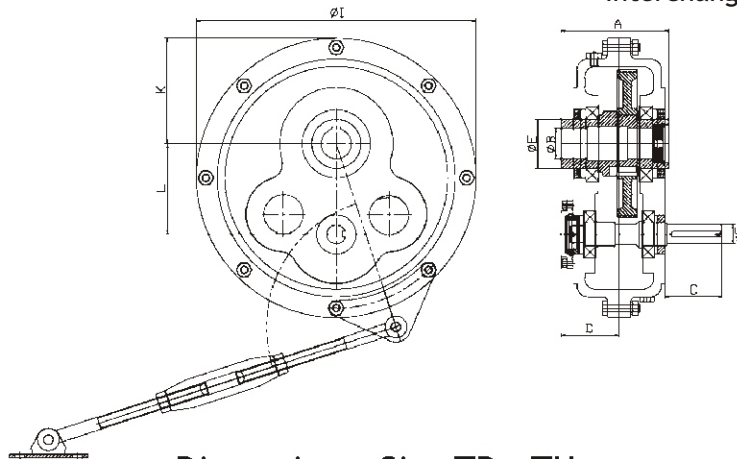

Dimensions, Size TD - TH

Size	Mass Kg	A	Keyed Hub øB F7	C	D	øE	ØF j6	F KEYWAY	øI	K	L
TD40	35	143	40 / 45 / 50	75	77	65	25	8x4x63	370	140	120
TE45	45	157	45 / 50 / 55	84	84	75	28	8x4x70	420	155	135
TF50	70	175	50 / 55 / 60	90	91	85	32	10x5x70	470	175	150
TG60	100	199	60 / 70	105	109	100	42	12x5x90	550	205	166
TH70	145	223	70 / 75 / 80 / 85	116	118	110	48	14x5.5x100	580	216	199

\*For Power Rating Refer Page 6 & 7

\*All Dimensions in mm

**Applications :** The gearbox is ideal for heavy bulk material handling machines meant for quarrying, mining and ready-mix plants etc. It is a reliable product capable of performing in rough environments.

## Selection

### \* SELECTION PROCEDURE

- 1) Determine required output speed
- 2) Determine power absorbed by the drive  

$$\text{Absorbed Power (kW)} = \frac{\text{Absorbed Torque (Nm)} \times \text{Machine Speed (rpm)}}{9550}$$
- 3) Determine Service Factor from table
- 4) Multiply the absorbed power by the service Factor
- 5) Using Table for Power Rating select the smallest gear unit that is suitable for transmitting this power at the output speed

### \* EXAMPLE

A torque of 1000 Nm is required to be transmitted on a conveyor at 70 rpm

The conveyor is not uniformly loaded and operates for 12 hours a day

Absorbed power =  $1000 \times 70 / 9550 = 7.32$  kW

Service Factor from table = 1.4

Selection Power  $7.32 \times 1.4 = 10.26$  kW

From Power Rating chart at 70 rpm size "F or TF" double reduction gear unit at 13.2 kW is the smallest for this application

Driven Machine Types Service Factors	Daily Operating Hours		
	Below 10 hours	Between 10-16 hours	Above 16 hours
<b>UNIFORM LOAD</b> Liquid and semi liquid mixers Centrifugal discharged equipments Bottling machine Fixed load carrier Ovens Washing machines Transmission shafts Centrifugal and gear pumps Wire drawing machines	1.0	1.12	1.25
<b>MODERATE SHOCK</b> Variable density mixers Variable load conveyors Cranes, movable carriers and lifters Rolling machines Heavy load elevators Drying stove Drying machines Lifting machines Piston pumps with 3 or more cylinders Pulp machines Drying machines Honing cylinders Wet pressing machines Small mixers and calendars Rotary screens Textile machines	1.25	1.4	1.5
<b>HEAVY SHOCK</b> Brick press Briquette manufacturing machine Conveyor band moving forward / backward and shaking Breaking machines Hammer mill Piston pumps with 1 or 2 cylinders Extruders Vibrators Forging mills	1.6	1.8	2.0

## Power Rating (kW)

OUT PUT RPM	A5	B5	C5	D5	E5	F5	FX5	G5
50	1.00	1.30	2.00	3.80	5.50	8.20	-	12.0
100	2.00	2.70	4.10	6.60	11.0	16.5	-	24.2
150	3.10	3.80	5.70	8.80	14.3	20.9	-	35.2
200	3.50	4.40	6.60	10.1	15.4	23.6	-	38.5
250	4.00	5.00	7.10	11.5	17.6	27.0	-	45.1
OUTPUT RPM	A13 A20	B13 B20	C13 C20	TD / D13 TD / D20	TE / E13 TE / E20	TF / F13 TF / F20	Fx13 Fx20	TG / G13 TG / G20
10	0.22	0.28	0.46	0.75	1.20	1.85	2.40	3.00
20	0.44	0.62	0.88	1.50	2.40	3.74	4.90	6.10
30	0.66	0.82	1.30	2.30	3.63	5.60	7.28	9.30
40	0.88	1.10	1.70	3.10	4.80	7.50	9.75	12.6
50	1.10	1.30	2.20	3.90	5.70	9.30	12.1	15.4
60	1.30	1.60	2.50	4.60	7.10	11.0	14.3	18.7
70	1.50	2.00	3.00	5.50	8.20	13.2	17.1	22.0
80	1.60	2.10	3.30	6.10	9.60	14.3	18.6	24.2
90	1.80	2.30	3.70	7.00	11.0	15.4	20.0	26.4
100	2.20	2.60	4.10	7.70	11.5	17.6	22.9	29.1
TORQUE AT 70 RPM NM	200	270	420	742	1100	1780	2340	2960
OIL Req'd. Lit.	0.4	0.5	0.7	1.2	1.90	2.5	3.5	4.5

For speeds higher than 70 rpm output use 13:1 or 5:1 ratios

Power rating calculation based on mineral oil

# Backstops



The simple accessory prevents reversal of the reducer and are ideal for use in Incline conveyors

It is important that the backstop is installed correctly to ensure a safe operation

### To install a backstop

- 1) Drain off oil if filled
- 2) Remove backstop cover
- 3) Fit the outer bush in the housing along with the key the bush should fit in snugly in contact with the gear casing
- 4) Determine the direction of shaft rotation
- 5) Fit the backstop, feeding the assembly while rotating the shaft in the direct of rotation

Note : If the opposite direction is required the backstop should be taken out and the sprag assembly inserted in the other direction

### For sizes G to L

A inner bush is supplied which has to inserted on top of the input pinion with keys prior to insertion of the sprag

- 6) Replace the backstop cover
- 7) Fill oil before use

### IMPORTANT

It is most important that the backstop is pressed into the housing gently and no hammer is used. The assembly maybe tapped in gently if necessary.

To change the direction of stoppage it can be done anytime with the removal of the sprag and turning it end to end in the housing.

The outer adaptor is provided with tapped holes to help in withdrawal of the bush.

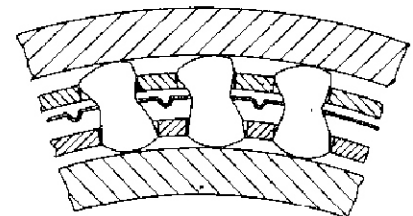
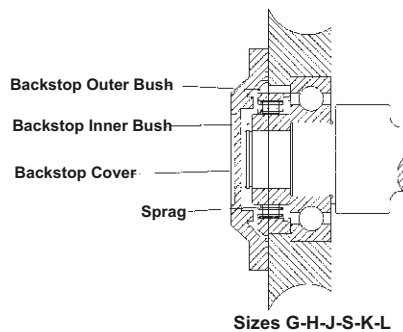
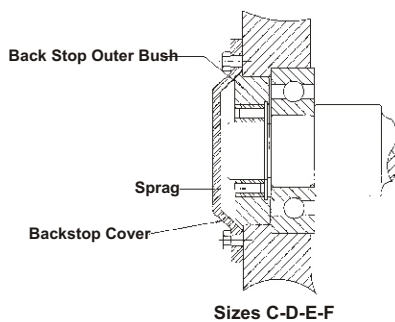

## Power Rating (kW)

OUT PUT RPM	H5	J5	Jx5	S5	K5	Ls5	L5
50	19.2	31.0	-	55.0	-	-	-
100	38.5	60.0	-	93.0	-	-	-
150	50.6	88.0	-	118.0	-	-	-
200	57.7	104.5	-	140.0	-	-	-
250	66.0	110.0	-	153.0	-	-	-
OUTPUT RPM	H13 H20	J13 J20	Jx13 Jx20	S13 S20	K13 K20	Ls13 Ls20	L13 L20
10	4.60	7.40	8.90	13.2	14.2	17.8	21.4
20	9.20	15.4	18.5	25.6	28.5	35.7	42.8
30	14.3	22.0	26.4	37.4	42.8	53.5	64.2
40	20.3	30.8	36.9	49.0	57.1	71.4	86.4
50	22.0	37.4	44.8	60.1	71.4	89.2	107.1
60	28.6	42.9	51.4	67.3	85.6	107.1	129.6
70	34.0	47.0	56.4	75.5	100.0	125.0	150.0
80	36.3	55.0	66.0	81.2	114.2	142.8	171.3
90	40.7	58.8	72.5	-	128.5	160.6	192.0
100	44.0	63.8	80.5	-	142.8	178.5	214.2
TORQUE AT 70 RPM NM	4500	6500	7695	11600	13640	17050	20460
OIL Reqd. Lit.	7.0	11.5	14	16.0	30	32	34

For speeds higher than 70 rpm output use 13:1 or 5:1 ratios

Power rating calculation based on mineral oil

## Motor Mounts

- \* A motor mount is available to fit on both sides of the gear unit
- \* A rigid base plate accommodates wide range of motor frame sizes
- \* Adjustment is available to ensure that the belt can be tensioned with ease.
- \* Each base plate is predrilled for various motor sizes and no further drilling is required
- \* Each assembly is electro plated to prevent corrosion and easy disassembly on usage
- \* It is recommended that larger frame size motors be mounted on an independent base.
- \* 'A max' is a dimension which must allow for belt tensioning
- \* 'A min' is a dimension which must allow for belt fitting.

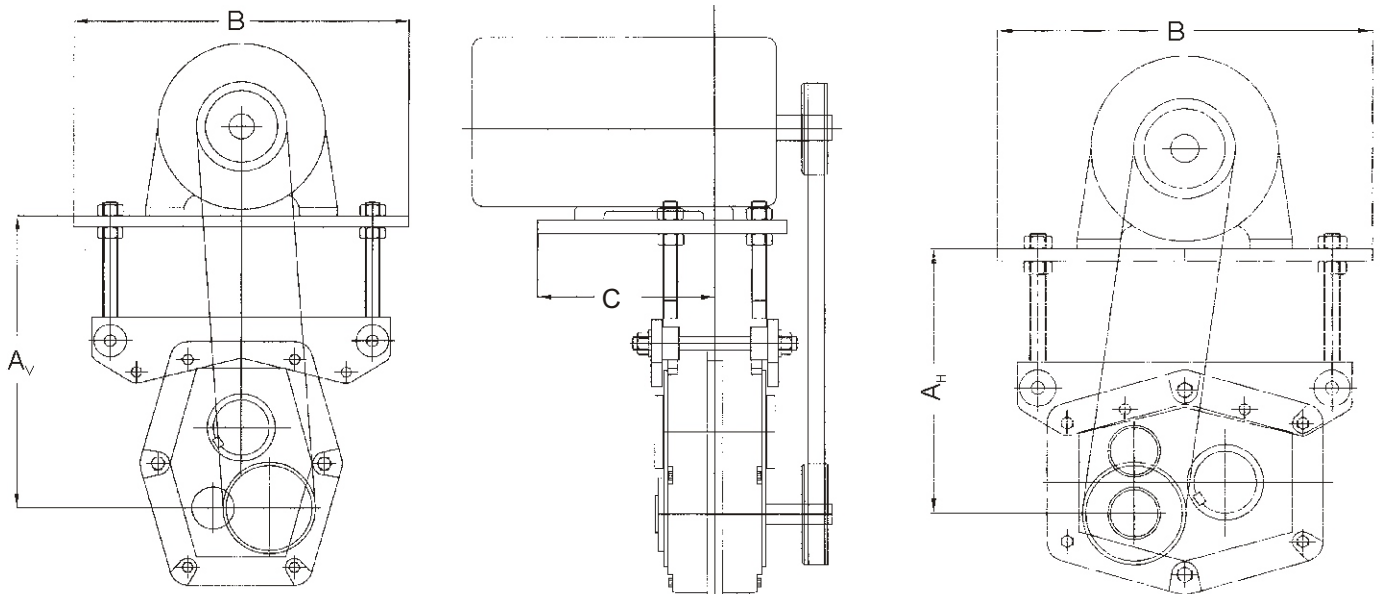
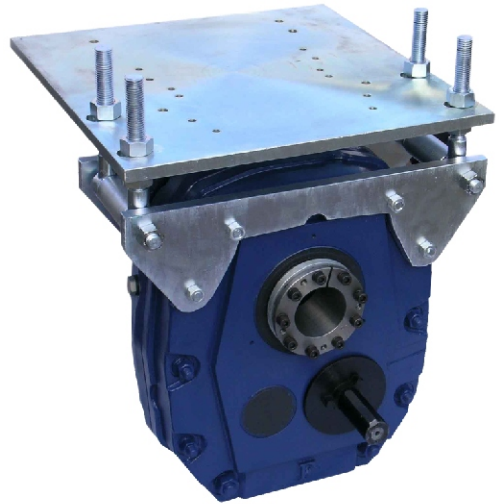

SIZE	A <sub>v</sub>		A <sub>H</sub>		B	C	METRIC MOTOR FRAME SIZE
	MIN.	MAX.	MIN.	MAX.			
B	210	265	165	220	270	140	63, 71, 80, 90S, 90L
C	260	330	200	270	370	190	63, 71, 80, 90S, 90L, 100L
D	300	370	235	305	370	165	71, 80, 90S, 90L, 100L, 112M
E	325	395	310	380	440	220	80, 90S, 90L, 100L, 112M, 132S, 132M
F	345	415	300	370	440	345	112M, 132S, 132M, 160M, 160L
G	375	425	300	370	520	340	112M, 132S, 132M, 160M, 160L, 180M, 180L
H	470	540	410	480	560	325	132S, 132M, 160M, 160L, 180M, 180L
J	570	645	465	535	510	365	132M, 160M, 160L, 180M, 180L, 200L
S	615	685	545	615	590	360	160M, 160L, 180M, 180L, 200L, 225S, 225M



# Lubrication



- \* Shaft Mounted Gear Units are supplied without oil and must be filled with the required quantity and type of lubricant before use.
- \* Correct quantity and type of oil is crucial to ensure correct operation and long life of the reducer.
- \* A breather **must** be used to ensure pressure build up and subsequent seal failure does not occur. A breather is supplied with each gear unit but not fitted.
- \* Viscosity of oil for various ambient temperatures and reducer **INPUT** speeds are shown below:-

Ambient Temp deg. C	Viscosity (mm <sup>2</sup> /s (cSt) at 40 deg. C)	
	Input speed r.p.m.	
	500 to 1,000 r.p.m.	1,000 to 2,000
-10 to + 5	VG 100	VG 100
0 to + 40	VG 320	VG 220
+35 to + 45	VG 460	VG 320

■ Maintenance :-

**Running in period** : After 500 hours drain oil and refill.

**Synthetic Oil** : Replace every 12,000 hours use.

**Mineral Oil** : Replace every 2,500 hours use.

### Recommended Synthetic Oils :-

BP EnerSyn HTX	Castrol AlphaSyn T - range	Esso	Kluber Klubersynth GH6	Mobil SHC / SHC-XMP	Shell Tivela WA / WB
----------------	----------------------------	------	------------------------	---------------------	----------------------

### Recommended Mineral Oils :-

BP Energol GR-XP	Castrol Alpha ZN / SP	Esso Spartan EP	Kluber Kluberoil GEM	Mobil Mobilgear	Shell Omala
------------------	-----------------------	-----------------	----------------------	-----------------	-------------

Quantity of lubricant and position of breather, sight glass and drain plug are shown in diagrams and table below:-

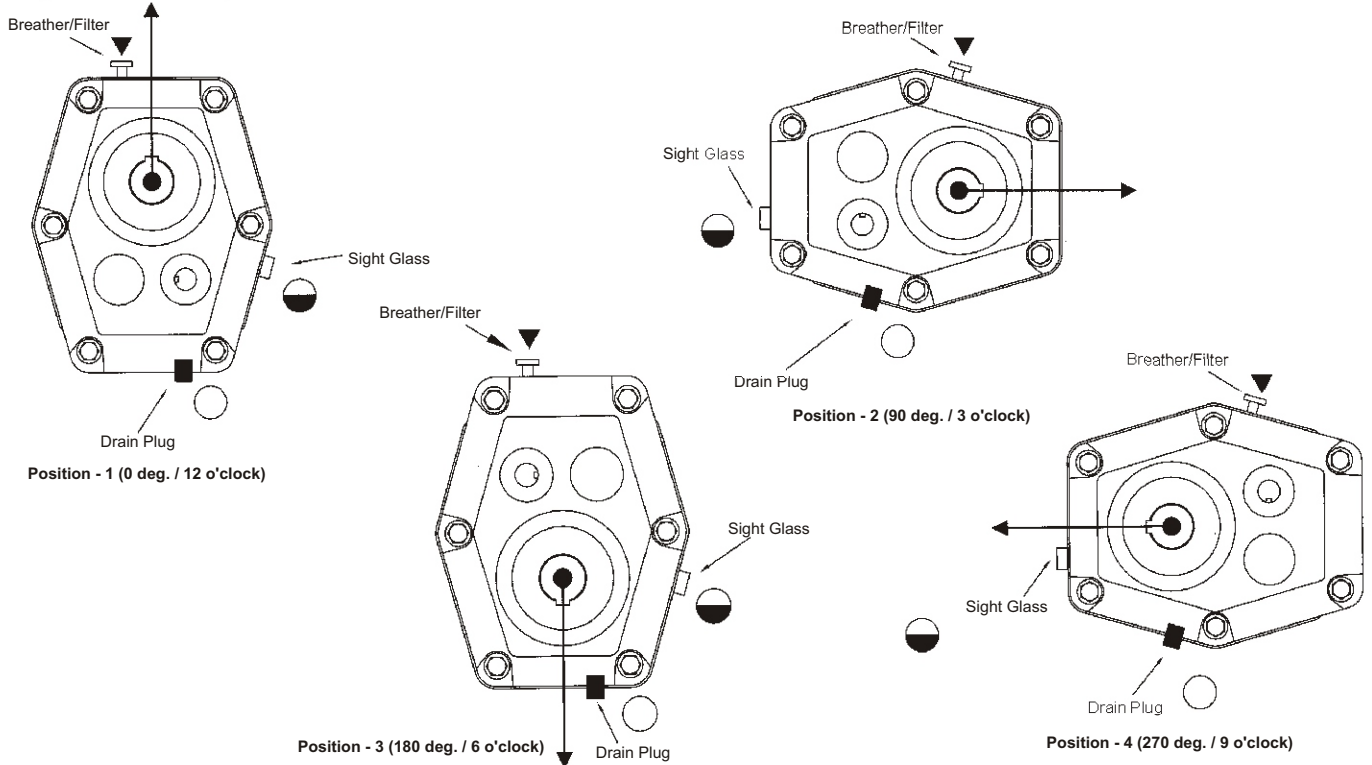

THE SIGHT GLASS CAN ONLY BE USED AS AN OIL LEVEL INDICATOR IN POSITIONS 1,2,3 OR 4 .

FOR ANY OTHER POSITION USE QUANTITY INDICATED AS ORIENTATION NEAREST IN TABLE BELOW :-

### Approx. S.M.G.U. size/oil quantity - Litres

Unit Orientation		B	C	D	E	F	G	H	J	S	K	L
Position 1	0 deg. / 12 o'clock	0.4	0.6	1.1	2.0	2.5	4.0	6.7	11.5			
	30. deg. / 1 o'clock	0.5	0.6	1.2	1.9	2.7	4.2	6.8	11.4	14	22	24
	60. deg. / 2 o'clock	0.5	0.7	1.3	1.9	2.9	4.4	6.8	11.3			
Position 2	90 deg. / 3 o'clock	0.6	0.7	1.4	1.8	3.0	4.5	6.7	11.2			
	120. Deg. / 4 o'clock	0.6	0.7	1.3	2.0	2.9	4.1	6.2	10.1	21	28	30
	150. deg. / 5 o'clock	0.5	0.6	1.2	2.2	2.7	3.7	5.7	9.0			
Position 3	180 deg. / 6 o'clock	0.5	0.6	1.2	2.3	2.5	3.3	5.3	7.8	17	20	22
	210. deg. / 7 o'clock	0.5	0.6	1.2	2.2	2.6	3.4	5.6	8.5			
	240. deg. / 8 o'clock	0.6	0.7	1.3	2.0	2.6	3.4	5.9	9.1			
Position 4	270 deg. / 9 o'clock	0.6	0.7	1.3	1.8	2.7	3.5	6.2	9.7	19	21	23
	300 deg. / 10 o'clock	0.5	0.7	1.2	1.9	2.6	3.7	6.4	10.3			
	330. deg. / 11 o'clock	0.5	0.6	1.1	1.9	2.6	3.9	6.6	10.9			

## Shaft Mounted Gear Unit

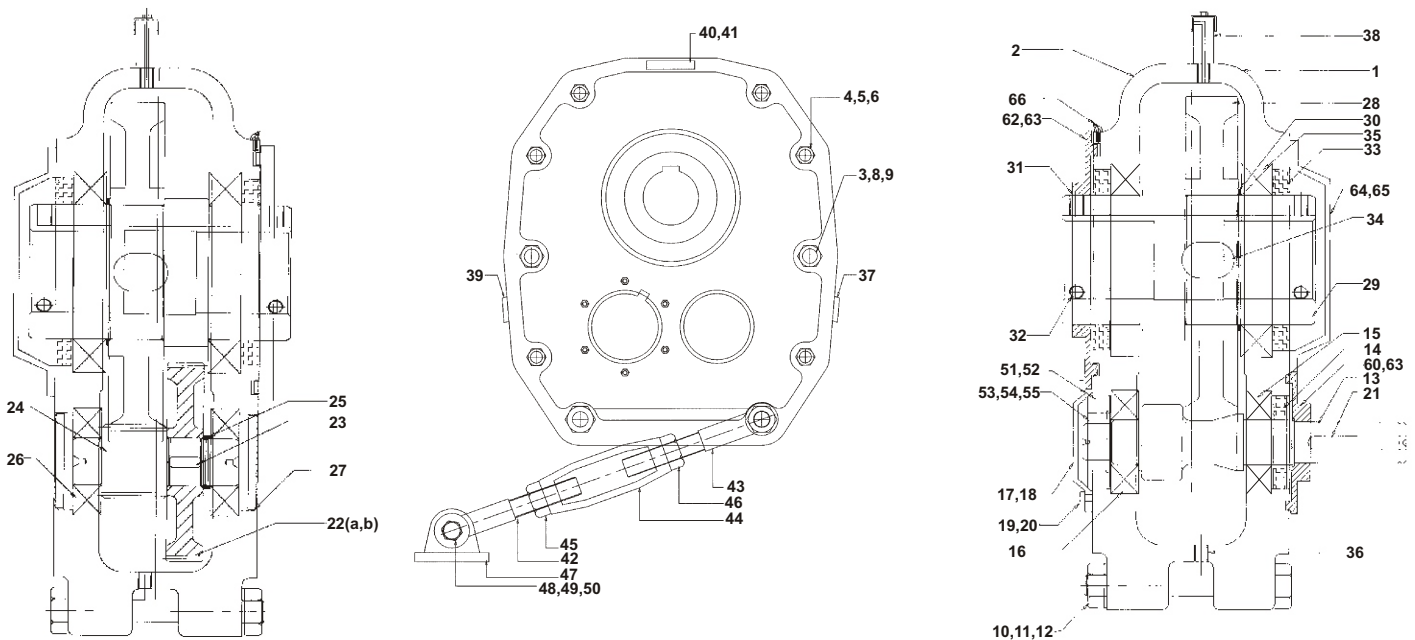

### Parts List - SMGU & T-Series

<ul style="list-style-type: none"> <li>1) Casing Half R.H.</li> <li>2) Casing Half L.H</li> <li>3) Hollow Dowel</li> <li>4) Hex Bolts</li> <li>5) Hex Nuts</li> <li>6) Lock Washers</li> <li>7)</li> <li>8) Plain Washer</li> <li>9) Hex Bolt / Nut / Lock / Washer</li> <li>10) Hex Bolt Torque Arm</li> <li>11) Hex Nut Torque Arm</li> <li>12) Lock Washer Torque Arm</li> <li>13) Input Pinion Ratio 5/13/20</li> <li>14) Oil Seal Input</li> <li>15) Bearing Input Front</li> <li>16) Bearing Input Back</li> <li>17) Backstop Cover</li> <li>18) Backstop O-Ring</li> <li>19) Backstop Bolts</li> <li>20) Backstop Bolt Washers</li> <li>21) Input Shaft Key</li> <li>22) Intermediate Gear 13/20</li> <li>23) Intermediate Gear Key</li> </ul>	<ul style="list-style-type: none"> <li>24) Output Pinion</li> <li>25) Spacer For Inter Pinion</li> <li>26) Intermediate Bearings</li> <li>27) End Covers</li> <li>28) Output Gear</li> <li>29) Output Hub - STD</li> <li>29a) Output Hub - ALT</li> <li>30) Output Spacer</li> <li>31) Hub Grub Screw on Key</li> <li>32) Hub Grub Screw</li> <li>33) Output Oil Seals</li> <li>34) Output Gear Key</li> <li>35) Output Bearings</li> <li>36) Drain Plug</li> <li>37) Sight Glass</li> <li>38) Breather Assembly</li> <li>39) Hex Oil Plug</li> <li>40) Name Plate</li> <li>41) Name Plate Dowels</li> <li>42) Torque Arm L.H.</li> <li>43) Torque Arm R.H.</li> <li>44) Turnbuckle</li> <li>45) Nut L.H.</li> </ul>	<ul style="list-style-type: none"> <li>46) Nut R.H.</li> <li>47) Fulcrum</li> <li>48) Fulcrum Hex Bolt</li> <li>49) Fulcrum Hex Nut</li> <li>50) Fulcrum Lock Washer</li> <li>51) Backstop Bush Outer</li> <li>52) Back Stop Bush - Key</li> <li>53) Back Stop Bush Inner</li> <li>54) Backstop Bush - Keys</li> <li>55) Backstop Bush - Circlips</li> <li>56) Hub Plate - T Series</li> <li>57) Hub Circlip - T Series</li> <li>58) Hub STD - T Series</li> <li>58a) Hub ALT - T Series</li> <li>59) Torque Arm Bracket - T Series</li> <li>60) Labyrinth Front</li> <li>61) Fill Oil - Sticker</li> <li>62) Labyrinth Back</li> <li>63) Labyrinth Screws</li> <li>64) Hub Cover</li> <li>65) Hub Cover Bolts</li> <li>66) Grease Nipple</li> </ul>
---	--	--

\*Improvements in design are continually being made  
The dimensions are subject to alternation without notice.

## T-Series

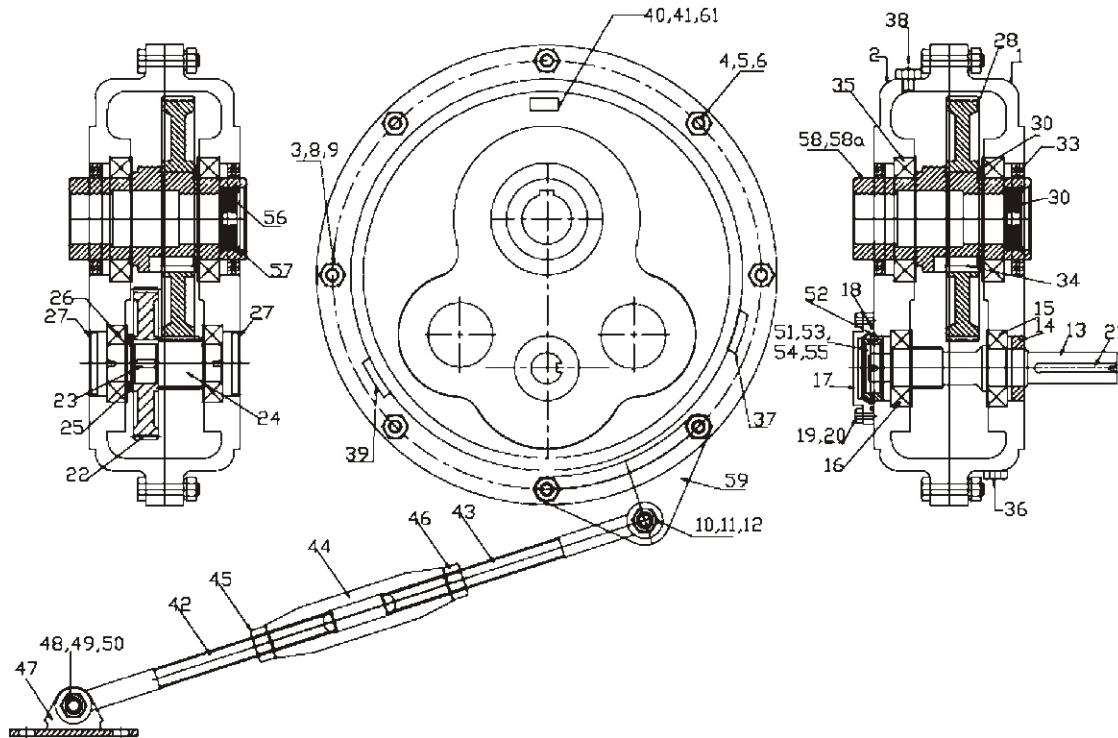

### Shaft Mounted Gear Unit - Other Accessories

- \* **Labyrinth Sealing** is available for protection against abrasive environment.
- \* **Output Hubs in Stainless Steels** are offered to achieve positive drive with a keyway and no fretting corrosion.
- \* **Extraction Collars** are available to extract the gear unit from the shaft.
- \* **Hydraulic Motor Mounts** are also available as an option.
- \* **Reducing Bushes** are available in steels and stainless steels.
- \* **Safety Covers** available at non- conveyor end.
- \* **One - way / Extended Breathers**

Shaft Size	Shaft Keyway Width x Depth
20	6 x 6
25	8 x 7
30	8 x 7
35	10 x 8
40	12 x 8
45	14 x 9
50	14 x 9
55	16 x 10
60	18 x 11
65	18 x 11
70	20 x 12
75	20 x 12
80	22 x 14
85	22 x 14
90	25 x 14
95	25 x 14
100	28 x 16
110	28 x 16
120	32 x 18
125	32 x 18
130	32 x 18
140	36 x 20
150	36 x 20

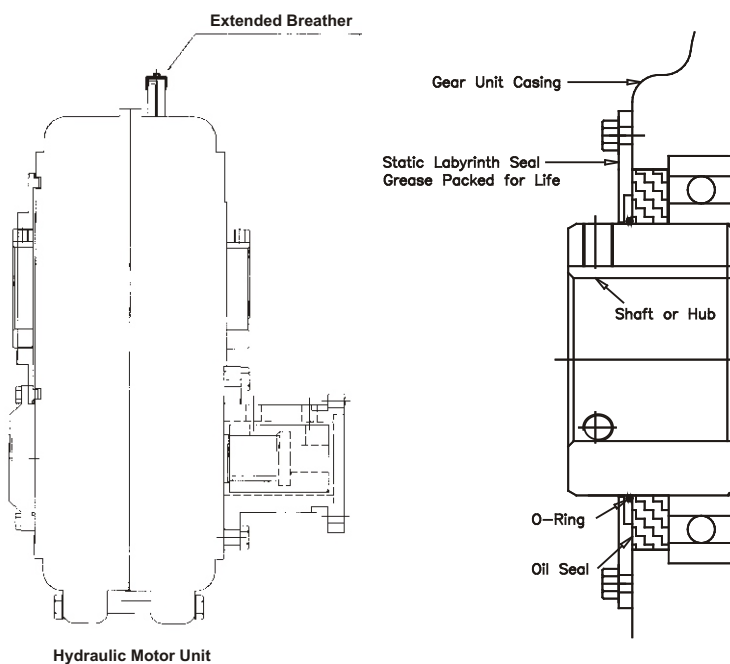

### Recommendation

- \* h7 Tolerance is Recommended for Shafts
- \* Torque Arms must be Installed in Tension



## Other Products by Powergear

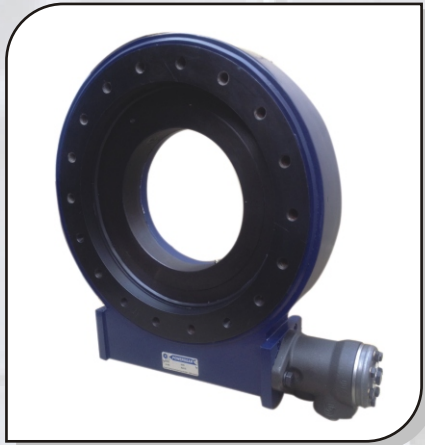

Worm Drive Slewing Rings

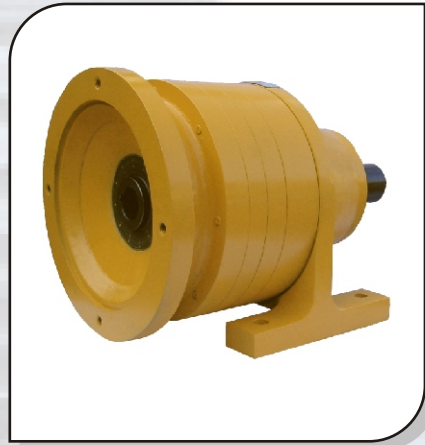

Planetary Gearboxes

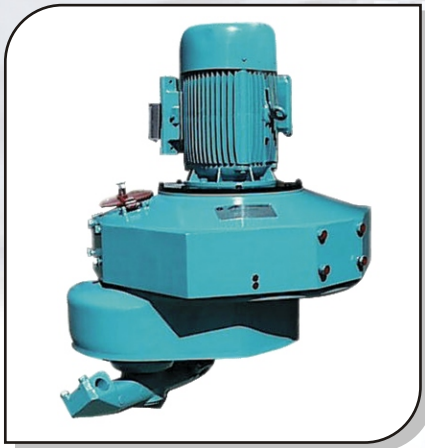

Planetary Counterflow Mixer Gearboxes

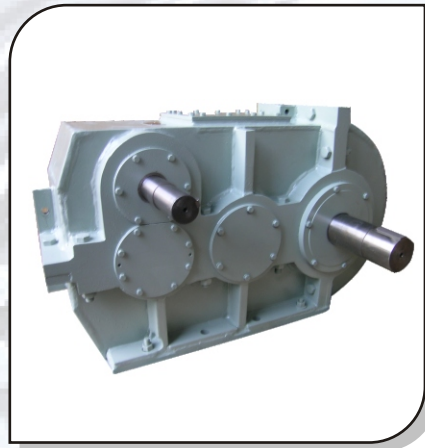

Helical Gearboxes

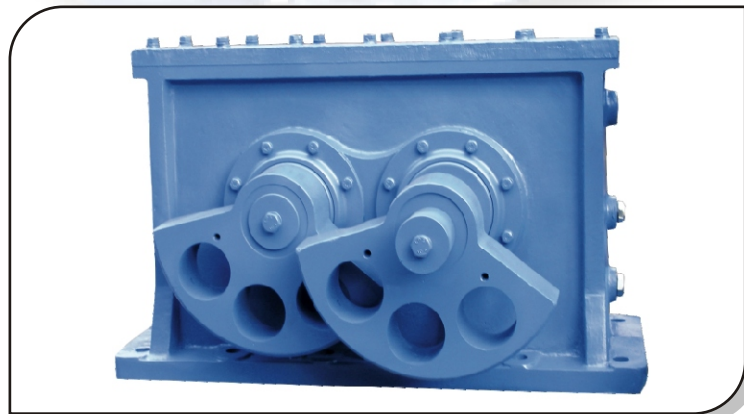

Directional Force Geared Exciter

## **Involute Powergear Pvt. Ltd.**

Unit - I : Plot No. 65, Sec. 27-C, Faridabad 121 003 - INDIA

Unit - II : Plot No. 69, Sec. 27-A, Faridabad 121 003 - INDIA

Tel : +91 (0129) 4279000, 4279001 Fax : +91 (0129) 4279009

E-mail : [info@involutetools.com](mailto:info@involutetools.com), Url : [www.gears-reducers.com](http://www.gears-reducers.com)



**POWERGEAR™**



**POULIGEAR<sup>fr</sup>**