

100 →

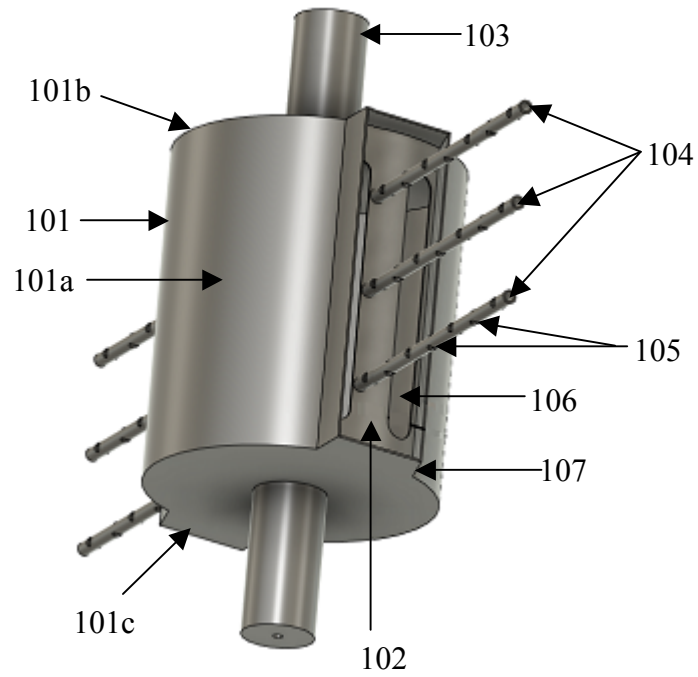

Fig. 1

Senthil Kumar N
Patent Agent for the Applicant

Applicant Name: Neeraj Nagaraj,
Application Number: 2023NNNNNNNN

Total No of Sheets: 07
Sheet No: 02

102 ↘

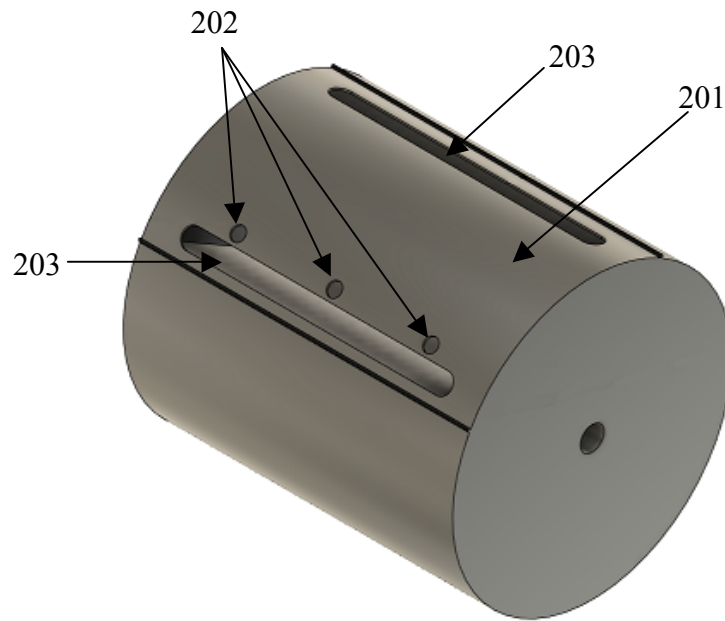

Fig. 2

Senthil Kumar N
Patent Agent for the Applicant

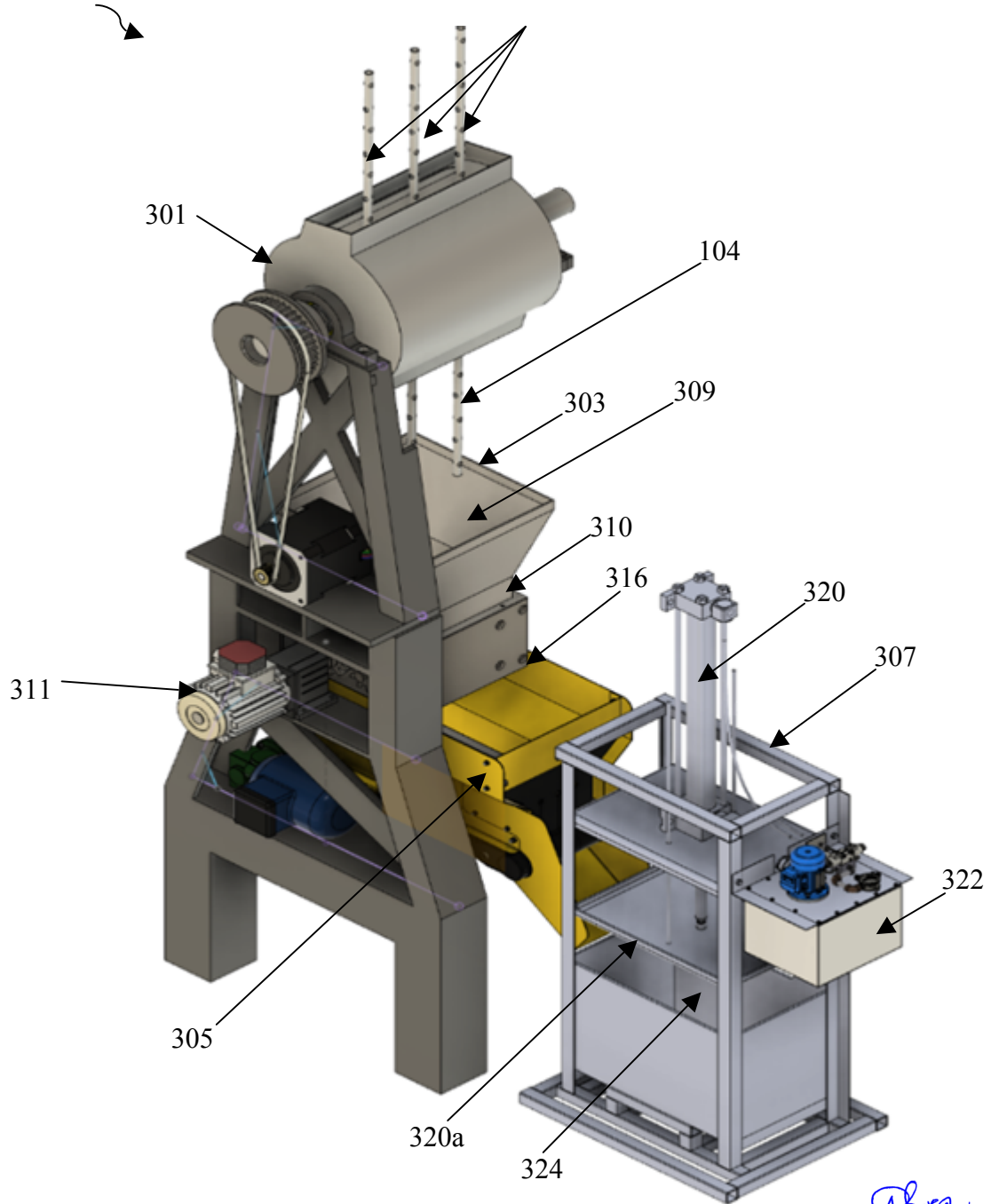



Fig. 3

Senthil Kumar N
Patent Agent for the Applicant

Applicant Name: Neeraj Nagaraj,
Application Number: 2023NNNNNNNN

Total No of Sheets: 07
Sheet No: 04

301 ↘

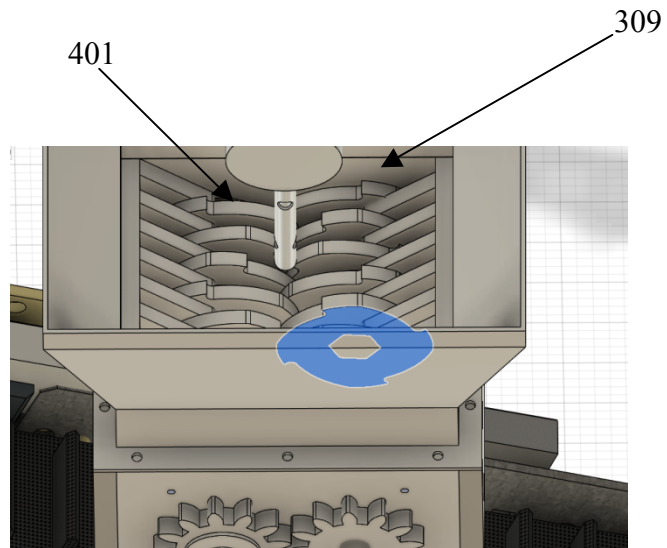

Fig. 4

Senthil Kumar N
Patent Agent for the Applicant

305 ↘

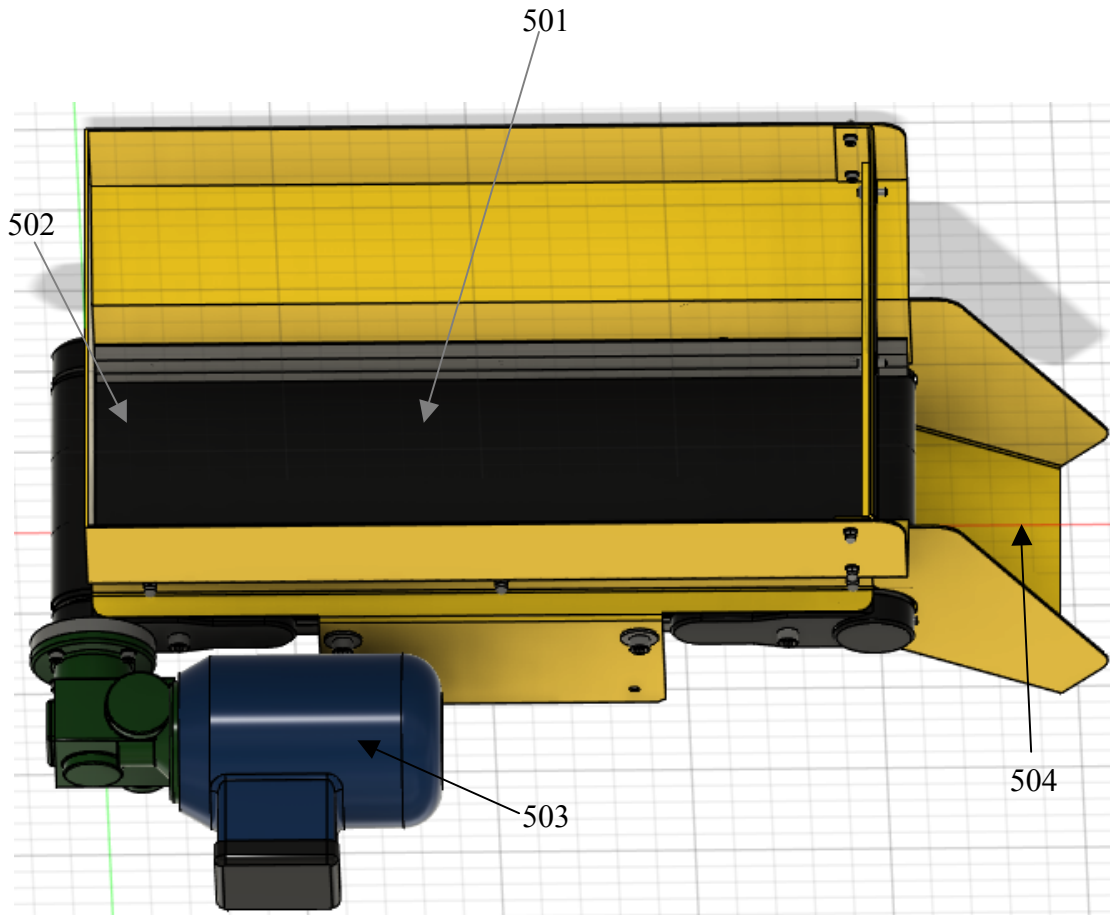

Fig. 5

Senthil Kumar N
Patent Agent for the Applicant

600 ↘

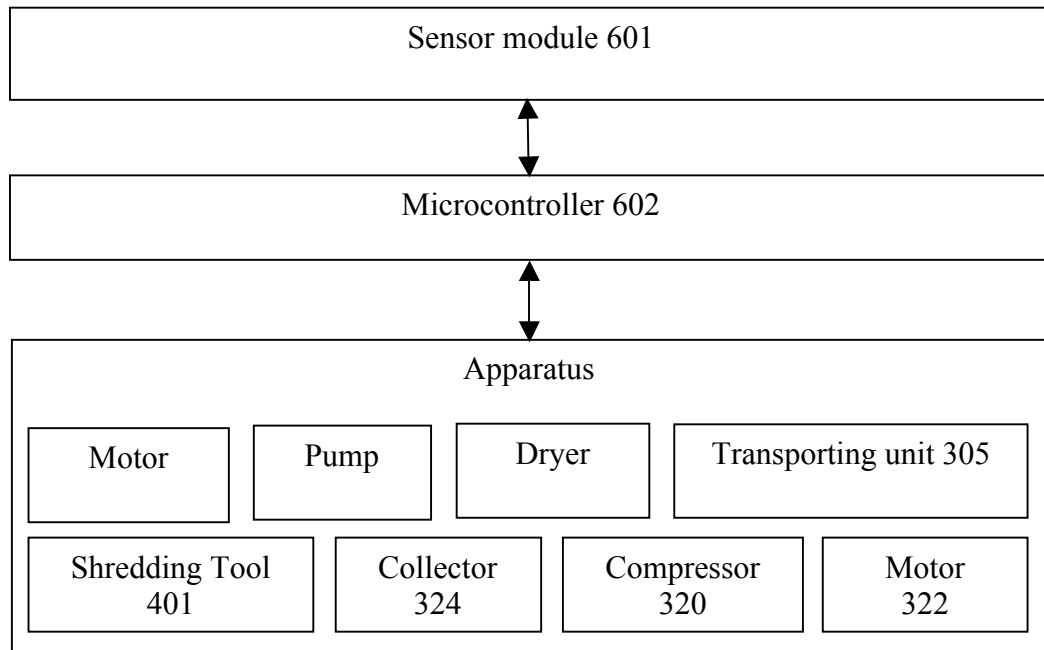

Fig. 6

Senthil Kumar N
Patent Agent for the Applicant

700 ↘

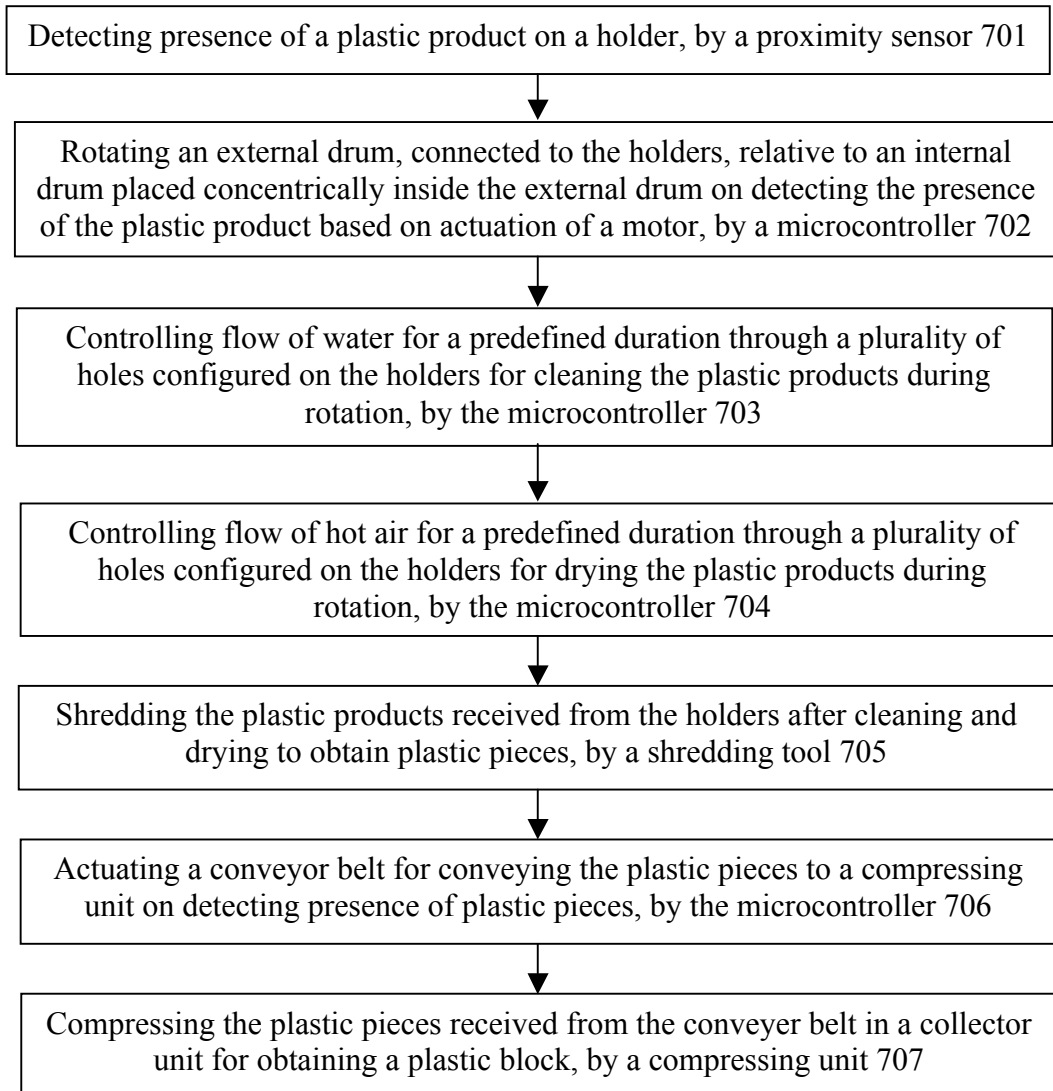

Fig. 7

Senthil Kumar N
Patent Agent for the Applicant