

Leak detection technology

For a clean and protected environment



Underpressure leak detector VLR 410/E



P: weather-proof design

An underpressure leak detector for the continuous monitoring of double-walled pipes.

Each leak in one of the both walls will be detected, before conveyed product will enter the environment.

A leak detection system with the highest environmental protection level in accordance to the European standard EN 13160, class I.

Liquids to be monitored:

Water polluting liquids:

- with a flash point above > 55°C, without potentially explosive vapours, e.g. diesel

For the monitoring of pipes:

Approved and made out of metal or plastic

- up to 25 bar pressure in the primary pipe

Approval:

Germany Z – 65.25 – 390

Type	Alarm ON	Pump OFF
VLR 410/E	> 410 mbar	< 540 mbar

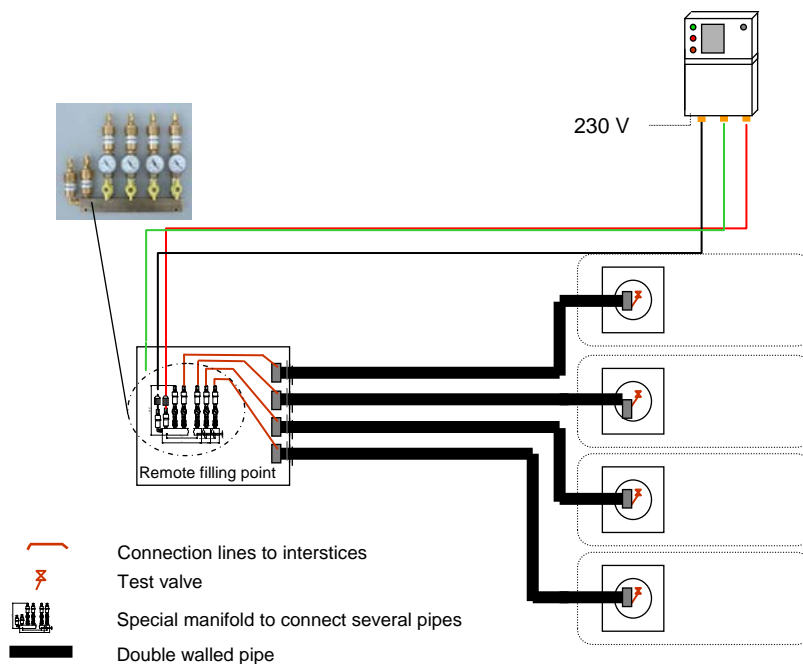

Distributed by:

