

AGENDA

Village of Shelby Planning Commission
Tuesday, November 17, 2020
Regular Scheduled Meeting– 6:30 P.M.



VIA ZOOM ONLY

Public access to this meeting can be accomplished online by connecting to “Join a Meeting” at: www.zoom.us, then entering the meeting I.D. : 836 7165 3816 and password: 676277. The link: <https://tinyurl.com/ShelbyPC1117> may also be used for access to the meeting. See the “Zoom Participation Process” on the Shelby website for more details and instructions (www.shelbyvillage.com)

Agenda Topics:

1. Call to Order:
2. Roll Call:
3. Pledge of Allegiance:
4. Review of Minutes of Previous Meeting: October 20, 2020 AR
5. Public Participation (Go to Shelbyvillage.com for instructions):
6. Old Business: Review Accessory Building Ordinance – Next steps AR
7. New Business: Preliminary Site Plan Review – Shelby Trails Apartments D
8. Adjournment:

AR- Action Requested
D- Discussion Item



**VILLAGE OF SHELBY
PLANNING COMMISSION
Tuesday, October 20, 2020 at 6:30 P.M.
MEETING PROCEEDINGS Via Zoom**

1. CALL TO ORDER:

The Village of Shelby Planning Commission Meeting was called to order at 6:34 P.M. by Vice Chairman John Sutton.

2. ROLL CALL:

Answering Roll Call: John Sutton, Paul Inglis, Samantha Near and Mark Baker.

Staff Present: Village Administrator Bill Cousins & Economic Development Fellow Emily Stuhldreher.

Absent: Tim Horton and Tara Kelley (arrived at 6:40)

3. PLEDGE OF ALLEGIANCE: All stood for the pledge.

4. MINUTES: Meeting of July 21, 2020

Paul Inglis moved to approve the minutes of the Regularly Scheduled Planning Commission meeting of July 21, 2020 as presented.

Seconded by: Samantha Near.

Roll call vote:

Ayes: Inglis, Baker, Sutton, Kelley, and Near.

Motion carried 5-0

5. CITIZEN PARTICIPATION: No Citizen Participation.

6. OLD BUSINESS:

a) 2020 Village of Shelby Master Plan – Draft Review with Emily Stuhldreher

The Planning Commission members reviewed the latest draft of the Village of Shelby Master Plan. Mark Baker noted the added photos looked good. John Sutton stated that the park shown as “DPW Park” on p. 58 is actually named “Tank Park”. Emily Stuhldreher will see that the change is made before the plan is distributed to the public.

Mark Baker moved to approve the draft Shelby Master Plan and recommend that the Village Council approve the plan for distribution.

Seconded by Tara Kelley.

Roll call vote:

Ayes: Baker, Kelley, Inglis, Near and Sutton.

Motion carried 5-0

b) Annual Report by Planning Commission (April, 2021)

Emily Stuhldreher described the process to review the last calendar year of work by the Planning Commission and create a report that would be presented to Council in April, 2021. Paul Inglis suggested the draft of the report could be created from the minutes of the meetings in 2020.

c) Pocket Park Update

Emily Stuhldreher reported to the Commissioners that the Village is in the process of purchasing the open space next to the Magooz Building. She noted that a grant has been submitted to assist with the purchase of the property. Additional fund-raising activities are being planned to assist with the development of the park next spring.

d) Vacant Planning Commission Seat

Emily Stuhldreher advised the Commissioners that the openings have been advertised in the newspaper and on the Village website. Two persons not living in the Village may serve on the Planning Commission if they have an interest in the Village (such as operate a business or own property). Paul Inglis suggested that Ross Field be contacted to apply. Emily also noted that she is looking into training for the commissioners as they will need 6 hours per year to satisfy the RRC requirements.

7. NEW BUSINESS:

a) Review Accessory Building Ordinance

Administrator Cousins reviewed the memo he provided with the agenda. Shelby limits the number of accessory buildings to one which can be an issue when a property owner has a small shed for their pool heater and pump, but would like another one for lawn equipment. He supplied examples of what other area communities allow. John Sutton noted that our ordinance is somewhat restrictive. Paul Inglis said we may not want to have an unlimited number allowed. Mark Baker said a maximum of two would be reasonable. Tara Kelly suggested the size should be limited based on the size of the lot. The Commissioners agreed to take a month to ponder this issue and discuss it at the next meeting.

8. ADJOURNMENT: Paul Inglis moved to adjourn the meeting at 7:03 P.M.

Seconded by: Tara Kelley.

Roll Call Vote:

Ayes: Inglis, Baker, Sutton, Kelley, and Near.

Motion Carried 5-0.

Planning Commission Meeting minutes are not official until approved at the next Regularly Scheduled Planning Commission Meeting.

Minutes Respectfully Submitted by Crystal Budde Clerk/Treasurer

Date

VILLAGE OF SHELBY

MEMO

Date: November 17, 2020

To: John Sutton, Co-Chair, Shelby Planning Commission
Planning Commission Members

From: Bill Cousins, Village Administrator

Subject: Review of Shelby Accessory Building Ordinance

The Planning Commission discussed the Accessory Building Ordinance last month and possible changes to it for the Village. After reviewing ordinances from area communities, Commissioners decided to check around the Village to see what effects an ordinance change would have for Shelby. The item is to be discussed again this month.

A change to the ordinance to allow two accessory buildings could be as simple as the following:

Number of buildings. No more than two detached accessory buildings shall be permitted on any lot; provided, however, dog pens and similar animal enclosures, swimming pools, satellite dish antennas, towers and antennas, and decks shall not be counted when determining the maximum number of permitted buildings or structures.

A copy of the current Shelby accessory building ordinance is attached. The portion being considered for alteration is section "g".

Should the Planning Commission wish to proceed with a proposal to change the ordinance, the following motion could be adopted:

Motion by _____ seconded by _____ to hold a public hearing at the next Planning Commission meeting for the purpose of hearing public comment on a proposed amendment to Section 3.11.g. of the accessory building ordinance that would allow for two accessory buildings to be constructed on a lot in the Village.

The Planning Commission has the option to take other action or no action at all on this issue.

Shelby Village Accessory Building Ordinance

SECTION 3.11 ACCESSORY BUILDINGS AND STRUCTURES (amended 5/09)

- A. Unless associated with a bona-fide agricultural operation, no accessory building shall be permitted on any lot which does not contain a main building unless a permit for a main building has also been secured for that lot.
- B. Attached accessory buildings and structures that are structurally part of the main building shall conform to the setback requirements of the main building.
- C. Detached accessory buildings shall be a minimum of ten (10) feet from any other building or structure.
- D. Detached accessory buildings in the Village shall be a minimum of five (5) feet from rear or side property lines and shall not be permitted in the front yard. Detached accessory buildings in the Township shall be set back fifty (50) feet from any property line.
- E. In the Township, accessory building(s) shall not be erected in any required front yard. In the Village, accessory buildings are not permitted in the front yard.
- F. In the Village Residential Districts, accessory buildings shall be of residential construction and shall be compatible with surrounding residential homes. Sheet metal walls are prohibited. Accessory buildings under two hundred (200) square feet are exempt (amended July 2007)
- G. In the Village, no more than one (1) accessory building shall be located on any parcel within any Zoning District, except that two (2) may be permitted when one (1) is a garage or other shelter for vehicles belonging to the residents.
- H. No accessory building shall be used in any part for residential dwelling or sleeping purposes.
- I. Manufactured homes, semi-trailers or other vehicles shall not be used as accessory storage structures.
- J. No accessory building shall occupy any portion of a required greenbelt or buffer in any District.
- K. After the construction of an accessory building upon a parcel of land, no subsequent division of that land shall be made which would cause the building located thereon to be in violation of the terms of this Ordinance.
- L. A zoning permit shall be secured prior to the placement of any accessory building.

- M. The maximum height of accessory structures in the Township shall be twenty four (24) feet.
- N. The total square footage of all detached accessory buildings associated with residential uses in the Village shall not exceed the following:

Minimum Lot Size	Maximum Square Footage (GFA)	Maximum Height (ft)
3,000 sq. ft.	384 sq ft (e.g. 16 x 24)	14
5,000 sq. ft.	672 sq ft (e.g. 24 x 28)	14
10,000 sq. ft.	864 sq ft (e.g., 24 x 36)	18
15,000 sq. ft.	1,080 sq ft (e.g. 30 x 36)	20
20,000 sq. ft.	1,200 sq ft (e.g., 30 x 40)	24
35,000 sq. ft.	1,600 sq ft (e.g., 40 x 40)	28
1 acres +	2,000 sq ft (e.g., 40 x 50)	28

VILLAGE OF SHELBY

MEMO

Date: November 17, 2020

To: John Sutton, Co-Chair, Shelby Planning Commission
Planning Commission Members

From: Bill Cousins, Village Administrator

Subject: Review of Shelby Trails Site Plan Review, 220 Walnut Street

The Shelby Trails Apartment Building project first came before the Shelby Zoning Board of Appeals for a Use Variance last Spring. The property is in the C-1 Central Business District which does not provide for apartment buildings. The project is a combination of four lots on Walnut between Third & Fourth Streets along with a parcel being created next to the Pavilion and Rail Trail that will be sold to the developer. Lastly, an easement agreement will be created to provide access to Fourth Street for the apartment building. The Use Variance was approved on March 9, 2020. While the use variance was approved, there was no determination made regarding zoning requirements for the apartments. This is discussed further later in this memo.

The Plans for the Shelby Trails 15-unit Apartment Building at 220 Walnut Street have been received and reviewed by the Village. Initially, the request from the applicant was for the proposal to receive Final Site Plan Review. However, the applicant has recently changed the request to be an Informal Site Plan Review of the Project. This action allows for the applicant to present the project to the Planning Commissioners and receiving comments about the plan. No action is to be taken at this meeting; the plans may be adjusted by the applicant as a result of the Planning Commissioner's comments along with the preliminary review by Village staff, then submitted for final review at a future meeting.

Items to be discussed that were described in the plan review include (Site plan review document is attached):

1. General – Requirements for apartments are detailed in Chapter 6 of the Shelby Zoning Ordinance (RR, R-1, R-2 & R-3 Residential Districts). Setbacks, lot coverage and building heights along with minimum sizes of units are detailed in Table 6-3. In the C-1 Central Business District, apartments are noted only in Table 8-4 (Parking Requirements) as accessory apartments as part of a commercial development. The issue becomes: "How should the apartments be reviewed? There are no requirements for apartments in the C-1 District!" The following describes what was used to review the plans.

2. Parking – Apartment parking requirements are detailed in Section 6.04 and Table 6.4: Parking requirements. Parking for apartments shall not be allowed in the front yard of the lot. 2.5 parking spaces are required for each apartment unit. However, in the C-1 District, accessory apartments require 1/5 parking spaces per unit. After much thought and discussion, 1.5 spaces were determined to be the standard to use (10 of the 15 units are one-bedroom units which may be more likely to require fewer spaces). The Planning Commission may provide their input on this issue. The site plan show that 23 spaces are supplied (meets ordinance), but 9 of them are in the street right-of-way on Walnut (not off-street and in the front yard) – not permitted. No on-street parking is allowed anywhere in the Village from November 15 to April 1 for snow removal purposes which also makes these spaces not able to be counted in the minimum requirements for the project.
3. More parking and driveway requirements - Section 13.02 of the zoning ordinance requires that maneuvering lanes be a minimum of 24' wide (22' is shown).
4. And more driveway requirements – Section 12.06.C.1.a. restricts apartments to have one driveway into the parking area. This reduces the impervious surface on the property to reduce storm water drainage and add to green space for the development. Additional drives are allowed when the road frontage exceeds 300' and trip generation numbers indicate the need for two access points. Neither standard is met for this item. Additionally, the slope of the lot creates a very steep surface if the Walnut access were to be allowed. The proposed 15% slope is more than twice as steep as a typical road constructed today. this would create dangerous conditions for vehicles using this drive. Not a good result.
5. Landscaping, signage and Lighting – No landscaping, signage and lighting plan was submitted. This sometimes happens and planning commission approvals note that, as a condition of final approval, the landscaping plan be submitted and approved prior to breaking ground for the project. That is requested for this development.
6. Exterior finishes – None have been submitted; the Planning Commissioners should discuss this with the development for inclusion in the final plans. Section 3.29 details the requirements for this item.
7. Minor details (Chapter 12) –
 - a. The final sets of plans will be required to be of a size that is easily read (1:20 scale).
 - b. The drawing shall be sealed by an architect or engineer licensed or registered in the State of Michigan. This is required to ensure that the plans meet a minimum of professionalism and meet basic qualities provided by properly trained professionals.
 - c. Utilities, nearby driveways and zoning of surrounding parcels will be required to be added to the final drawings.



November 9, 2020

Kendra Thompson
Kendra C. Thompson Architects, PC
803 Cherry St.
Manistee, MI 49660

VIA – Email - Thompson.kendra@sbcglobal.net

Re: 220 Walnut, Shelby, MI
Site Plan Review

Dear Ms. Thompson:

The review of the site plan for the apartment building at 220 Walnut is almost complete; the Fire Department will not have their review finished until Wednesday of Thursday. As I have a number of items that need to be addressed, I felt it best to send this to you now.

The following items need to be resolved before the Planning Commission can act on the site plan (Sections of the Zoning Ordinance noted where applicable):

1. (12.03.B.1) Twelve copies of the site plan at a scale of 1:20 are required. As revised plans are expected to be submitted to address the corrections noted herein, only nine (9) full-size sets of plans will be required as some of the review was accomplished on the 1/2 size sets. However, the resulting scale is too small for the commissioners to view.
2. (12.03.C) The following need to be added to the drawings:
 - a. The drawings are to be sealed by an architect or engineer
 - b. Size and location of utilities – I could not find the electrical connections. Also, there is no water service line for the fire protection system (it must be connected to the main separately from the potable water service).
 - c. Adjacent zoning is shown as C-1 (sheet c-101). Zoning to the West is R-2.
 - d. Show all buildings, parking and driveways within 100' of the subject property (missing on the west side of Walnut).
3. (12.06.A.3& 4) – There is no landscaping, signage or lighting plans. It was agreed that these will be submitted separately to the Planning Commission prior to the breaking of ground for the project.
4. (12.06.C.1.a) The building has two access driveways. Only one is allowed. This will reduce the amount of impervious surface on the property. Also, by eliminating the driveway off Walnut will eliminate the severely steep drive into the complex.

5. Note: This will also assist in resolving the parking issue noted later in this review.
6. (12.06.B) The sidewalk is noted as being 5' wide-typically. Verify that the sidewalks will be a minimum of 5' wide.
7. (3.29) Provide details of the exterior finishes of the building including colors and material. Pay particular attention to sections C, E, G, H & I. Note that section E provides direction for 50% of the main floor exterior to be of brick or other similar material.
8. Parking. (13.02) We discussed this a few times and it was determined that the lesser of the apartment off-street parking requirements would be used for this project (1.5 vs. 2.5 spaces per apartment. The total parking required for this proposal is 1.5 per apartment x 15 apartments + 1 for the office = 23. The plan (c101) shows 23 spaces, but only 14 meet the off-street parking requirement (13.02.A.4). The parking on Walnut is not off street (therefore not allowed). Additionally, the Village does not allow any on-street parking from 2am – 6am from November 15 – April 1 for snow plowing. For both reasons above, the parking shown along Walnut must be removed from the plans. The parking lot along the east side of the building could be expanded to the north to create additional spaces.
9. (13.02.E.3) The driveway and maneuvering lanes in the parking lot must be 24' wide to accept two-way travel (shown at 22').
10. Miscellaneous –
 - a. You verified (by email) that there will be one water meter for the building.
 - b. What are the slopes of the sidewalks at the barrier-free parking space?

In order for a complete review of the plans once they are revised, they should reach the Village office on or before December 1. This will ensure that the review can be made and the site plan be on the December 15th Planning Commission agenda.

Please contact me with any questions or concerns. I will advise you of the Fire Department comments as soon as I receive them.

Sincerely,

William T. Cousins III
Shelby Village Administrator



Planning & Zoning Application

218 N. Michigan, Shelby, Michigan 49455

Ph: 231-861-4401 Fax: 231-861-7449

E-mail: administrator@shelbyvillage.com

Select one or more of the items below, fees must be paid in full before any action can be taken. Items requiring Planning Commission action must be heard at a Public Hearing, published at applicants expense before action can be taken.

<input type="checkbox"/>	Residential additions, Detached Garage, Swimming Pool Permit \$25.00	<input type="checkbox"/>	Site Plan Review by Zoning Admin. \$25.00
<input type="checkbox"/>	Demolition (Razing), residential - \$50.00 + \$500.00 escrow		Items below require Planning Commission Review. Applicant must supply 11 copies of plans to the commission.
<input type="checkbox"/>	Demolition (Razing), Commercial - \$100 + performance Bond equal to demo cost	<input checked="" type="checkbox"/>	Commercial / Industrial Site Plan Review - \$300.00
<input type="checkbox"/>	Special Meeting – Actual cost of PC or Council wages	<input type="checkbox"/>	Special Use Permit - \$300.00
<input type="checkbox"/>	Variance - \$25.00 + Publication & any other cost	<input type="checkbox"/>	PUD - \$300.00
<input type="checkbox"/>	Ordinance Interpretation – Actual cost, min.\$500.00, excess refunded/returned	<input type="checkbox"/>	PUD - Amendment - \$300.00
<input type="checkbox"/>	Fence, Shed, Deck, Pad, Foundation, Wall & Overhang Signs permit- \$10.00	<input type="checkbox"/>	Zoning Amendments - \$250.00 + actual cost of Publication & Legal fees
<input type="checkbox"/>	Basic zoning compliance permit for structures not listed \$25.00	<input type="checkbox"/>	Rezoning - \$300.00

Applicant Information:

Applicant is the: Owner Lessee Contractor/Architect

Name: KEMORA C. THOMPSON ARCHITECTS Organization: KENDRA THOMPSON
 Address: 803 CHERRY STREET City/State/Zip: MANISTEE, MI 49660
 Phone (H): 231. 723. 4195 Cell Phone: 231. 510. 5012
 Email: thompson.kendra@sbcglobal.net

I hereby attest that all information on this application is, to the best of my knowledge, true and accurate:

Signature: [Signature] Date: 11/2/2020

Access Permission

I hereby grant permission for members of the Village of Shelby (Planning Commission) (Zoning Board of Appeals) (Village Council) (Staff) to enter the property described below (or as described in the attachments) for the purpose of gathering information related to this application. (Note to applicant: This is optional and will not affect any decision on your application)

Signature of Owner: [Signature] Date: 11/2/2020
 AGENT

Address/Location of Subject Property: 220 WALNUT STREET

Current Zoning & Use of Subject Property: C-1, VACANT

If the applicant is not the owner of the property, complete the following:

Owner's Name: OCHC SHELBY LHDA LP
 Address: 204 WASHINGTON STREET
 City/State/Zip: HART, MI 49420
 Phone: 231. 873. 2222 Signature: [Signature]
 (KTA)

VILLAGE OF SHELBY

218 N MICHIGAN AVENUE

SHELBY, MI 49455

Receipt: 150079145

11/02/20

Page

Cashier: Clewandowski

Received Of:

The sum of: **\$300.00**

ZONING ZONING PERMIT & FEES

300.00

Total 300.00

Balance Due

TENDERED:

CHECKS

9445

300.00

Signed: _____



LETTER OF TRANSMITTAL

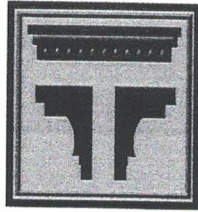

kendra c.

THOMPSON

architects, p.c.

TO: Mr. Bill Cousins, Village Administrator
Village of Shelby
218 N. Michigan Avenue
Shelby, MI 49446

DATE: 02 November 2020

PROJECT: Shelby Trails Apartments
220 Walnut Street
Shelby, MI

ATTN:

PROJ. NO: KT-219026

We are sending you: Attached

Under Separate Cover

Shop Drawings

Prints

Samples

Copy of Letter

Change Order

Other

<u>Copies</u>	<u>Date</u>	<u>No.</u>	<u>Description</u>
3	02Nov2020		Site Plan Review Drawings: 24x36 Full Size
9	02Nov2020		Site Plan Review Drawings: 12x18 Half Size (Note: Scale indicated to be half)
1	02Nov2020		Site Plan Review: Project Narrative

THESE ARE TRANSMITTED AS FOLLOWS:

For Approval

Approved as submitted

Resubmit

For your use

Approved as noted

Returned for
corrections

For review/comment

For Bids

REMARKS:

Please contact me should you have any questions or want to discuss prior to 11/17th Planning Board meeting. You can reach me at (231)510-5012 (cell or (231)723-4195 (office).

Thanks!

COPY TO:

SIGNED: Kendra C. Thompson, RA



kendra c.
THOMPSON
architects, p.c.

SITE PLAN REVIEW NARRATIVE

SHELBY TRAILS APARTMENTS
220 WALNUT STREET
SHELBY, MICHIGAN

02 NOVEMBER 2020
PAGE 1 OF 4
KTA PROJ. NO: 219026

Shelby Trails Apartments will feature 15 units of new construction, affordable rental housing.

Development: Shelby Trails Apartments

Owner: OCHC Shelby LHDA LP
204 Washington Street
Hart, MI 49420

Location: The development will be in the Village of Shelby, Oceana County, Michigan on property located at 220 Walnut Street with east boundary bordering the Hart-Montague Rail Trail and connecting northward to 4th Street.

Building Description: The design concept for this proposed multifamily development is to provide an upscale living environment at very modest rental rates. There will be a total of (10) one-bedroom units and (5) two-bedroom units. The multi-story building will be a wood framed structure have vinyl exterior siding, stone accent areas and asphalt shingled roofing. The building will be provided with an elevator, two stairwells and provide ADA accessibility to all unit entries. Special provisions will be provided with (1) One-bedroom unit and (1) Two-bedroom unit being fully ADA accessible and the remaining units being ADA adaptable. Additionally, a small community room for use by residents and two support office are provided.

Legal Description: Lots 14, 15, 16 and 17, Block 15, Village of Barnett, according to the recorded plat thereof, Village of Shelby, Oceana County, Michigan

and

Part of the abandoned railroad right of way, in the Plat of the Village of Barnett, Village of Shelby, Oceana County, Michigan described as beginning at the Southeast corner of Lot 14, Block 15 in said Village of Barnett Plat; thence 172.33 feet along a curve to the left, said curve having a radius of 2225.99 feet and is subtended by a chord which bears N.08°-02'-24"E., 172.29 feet; thence S.88°-54'-25"E., 135.22 feet to a point on a curve; thence along said curve to the right 87.41 feet, said curve having a radius of 2360.78 feet and subtended by a chord which bears S.06°-36'-44"E. a distance of 87.41 feet; thence N.80°-39'-25"W., 53.40 feet; thence S.09°-18'-24"W., 91.62 feet; thence N.89°-36'-49"W., 81.73 feet to the point of beginning, containing 0.42 acre of land, more or less, and subject to any easements of record.

Easement Description:

Part of the abandoned railroad right of way, in the Plat of the Village of Barnett, Village of Shelby, Oceana County, Michigan described as beginning at the Northeast corner of Lot 19, Block 15 of said Village of Barnett; thence S.88°-36'-15"E., 34.94 feet to a point on a curve; thence along said curve to the right a distance of 127.75 feet, said arc having a radius of 2360.78 feet and subtended by a chord which bears S.04°-00'-04"W. a distance of 127.73 feet; thence N.88°-54'-25"W., 35.04 feet to a point on a curve; thence along said curve to the left a distance of 127.94 feet, said arc having a radius of 2325.78 feet and subtended by a chord which bears N.04°-02'-32"E. a distance of 127.92 feet to the point of beginning, containing 0.10 acre of land, more or less.

Amenities:

- Enterprise Green Energy Efficient Design`
- Modern kitchen with full appliance package: dishwasher, disposal, refrigerator, range, microwave and exhaust fan
- High-efficiency furnaces and central air
- Large closet and ample storage areas
- Washers and dryers
- Computer outlets and cable TV hook-ups
- Community room
- Elevator
- Full fire-suppression system

Energy Efficiency: The new structure is designed and will be constructed to achieve Enterprise Green Communities Energy Efficient Design rating. EGC Design provides a framework for identifying and implementing practical and measurable green building design, construction, operations and maintenance solutions. Certification verifies that the buildings are designed and built using strategies aimed at achieving high performance in key areas of human and environmental health, sustainable site development, water savings, energy efficiency, materials selection and indoor environmental quality. Prerequisites for a rating include items such as resource management criteria during construction activity, regionally sources building products, pollution prevention, quantity and quality control of storm water design, water use reduction techniques and fundamental commissioning of building energy systems.

Management: Professional management and maintenance will be provided to provide the best possible service to the residents and to ensure a friendly, safe, and well-managed environment. A Resident Services Coordinator will be available on-site to assist residents with any supportive service needs. The Owner of the development assumes all responsibility for the maintenance and repair of the private drive, sidewalks and site utilities beyond the public taps.

Site Information: To facilitate the development of the proposed project, a variance to allow for the proposed multi-family facility within the C-1 Central Business District was granted by the Shelby Zoning Board of Appeals on March 9, 2020. Based upon this, the basis for design development for the planned multi-family dwelling project is as outlined below:

1. Zoning Section 8.04

Lot Requirements:

Required Min. Area = None
Required Min. Width = None
Required Min. Depth = None
Required Max. Coverage = 90%

Provided Lot Coverage = 40% (+/-)

Building Setbacks:

Required, Front: Align with other structures
Note: Others vary from 5 ft at south to 27 ft at north
Required, side & rear: 0 ft

Provided, Front (west): 13 ft to roof overhang (15 ft to wall face)
Provided, side south: 20.7 ft (+/-)
Provided, side north: 51.1 ft (+/-)
Provided, rear: 56.8 ft (+/-)

Building Height:

Required, max.: 50 ft
Required, min.: 35 ft and 2 stories or match adjacent bldgs.

Provided: 33'-0" +/- mean grade to mean. height of roof
33'-3" +/- west grade to ridge
44'-2" +/- east grade to ridge
Structure is 2-sty at west façade and 3-sty at east façade with sloping grade on north and south building sides

Parking:

Required: 1.5 per dwelling unit
15 units = 22 spaces

Provided: 23 total
22 for dwelling units
1 for office staff

Required, size: 162 sf min

Provided: 162 sf (9 ft x 18 ft, or per ADA for HC spaces)

2. Zoning Section 6.03

Dwelling Unit, min. area:

Required, One-bdrm: 650 sf
Required, Two-bdrm: 750 sf

Provided, One-bdrm: 798 sf (+/-)
Provided, Two-bdrm: 1029 sf (+/-)

Landscaping:

Careful attention has been given to maintain most significant trees on the parcel, with minimal removal as required to accommodate the required parking and building placement. The project will incorporate extensive landscaping using a wide variety of native plant materials to create the optimal result in appearance, livability, and Enterprise Green Community rating. Landscaping design will comply with the Village of Shelby's Landscaping specifications and requirements. Final landscape design plans, including layout and species, will be submitted separately for municipal review/approval prior to commencing construction.

Site Signage:

A simple project sign will be developed and outlined on final construction documents. It is anticipated signage will be placed near the Walnut Street main entry and consist of low-profile wood sign supported on detailed posts with a landscaping surround. Sign will incorporate project name, leasing contact information and MHSDA logo. Signage will comply with the Village of Shelby's signage requirements. Final signage design will be submitted separately for municipal review/approval prior to commencing construction.

Site Lighting:

Pole mounted, 15-foot high, LED down lit site lighting has been incorporated into the site design. If desired, final lighting photometrics can be provided for municipal review/approval prior to commencing construction.

**Anticipated
Construction
Schedule:**

Construction is anticipated to commence Spring 2021 and require an approximate 12-month construction schedule.

SITE



LOCATION MAP
NO SCALE

15-UNIT HOUSING PROJECT

SHELBY TRAILS

OCHC SHELBY LHDA LP
220 WALNUT STREET
SHELBY, MICHIGAN

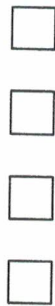

SITE PLAN REVIEW NOVEMBER 2, 2020

RESIDENTIAL UNIT TYPES:

ONE BEDROOM UNITS	15 UNITS
TOTAL ONE BEDROOM UNITS	15
TWO BEDROOM UNITS	0
TOTAL TWO BEDROOM UNITS	0
TOTAL UNITS	15 RESIDENTS

SCHEDULE OF DRAWINGS:

T103	COVER SHEET
C100	ENGINEERING NOTES
C101	PROPOSED GRADING & UTILITY PLAN
C102	DETAIL SHEET
A201	PROPOSED LOWER LEVEL PLAN
A202	PROPOSED MAIN LEVEL & UPPER LEVEL PLANS
A203	PROPOSED UNIT PLANS
A205	PAVING ELEVATIONS

MECH./ELEC./PLB'G. ENGINEER:

Nealis Engineering
830 Cottageview Drive
Suite 102
Traverse City, MI 49684
t: 231.933.0510

CIVIL ENGINEER:

Spicer Group
302 River Street
Mamsee, MI 49660
t: 231.794.5620

PROJECT TEAM

ARCHITECT:

Kendra C. Thompson
Architects, P.C.
803 Cherry Street
Mamsee, MI 49660
t: 231.723.4195

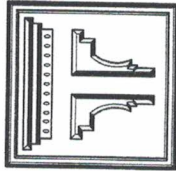

kendra c.
THOMPSON
architects, p.c.
803 Cherry Street
Mamsee, MI 49660
Tel: 231.723.4195
thompson.kendra@thompson-architect.com
www.thompson-architect.com



PROJECT NAME NEW HOUSING PROJECT: SHELBY TRAILS 220 WALNUT STREET SHELBY, MICHIGAN													
DRAWING TITLE COVER													
SEAL	<table border="1"> <tr> <td>DRAWN</td> <td>ACT PROJECT NO</td> </tr> <tr> <td>SCALE</td> <td>ALZ DENS</td> </tr> <tr> <td>DATE</td> <td>DRAWING NO</td> </tr> <tr> <td>SCALE</td> <td>T100</td> </tr> <tr> <td>DATE</td> <td>SHEET NO</td> </tr> <tr> <td>SCALE</td> <td>1 OF 7</td> </tr> </table>	DRAWN	ACT PROJECT NO	SCALE	ALZ DENS	DATE	DRAWING NO	SCALE	T100	DATE	SHEET NO	SCALE	1 OF 7
DRAWN	ACT PROJECT NO												
SCALE	ALZ DENS												
DATE	DRAWING NO												
SCALE	T100												
DATE	SHEET NO												
SCALE	1 OF 7												

Copyright 2020 Kendra C. Thompson Architects, P.C.

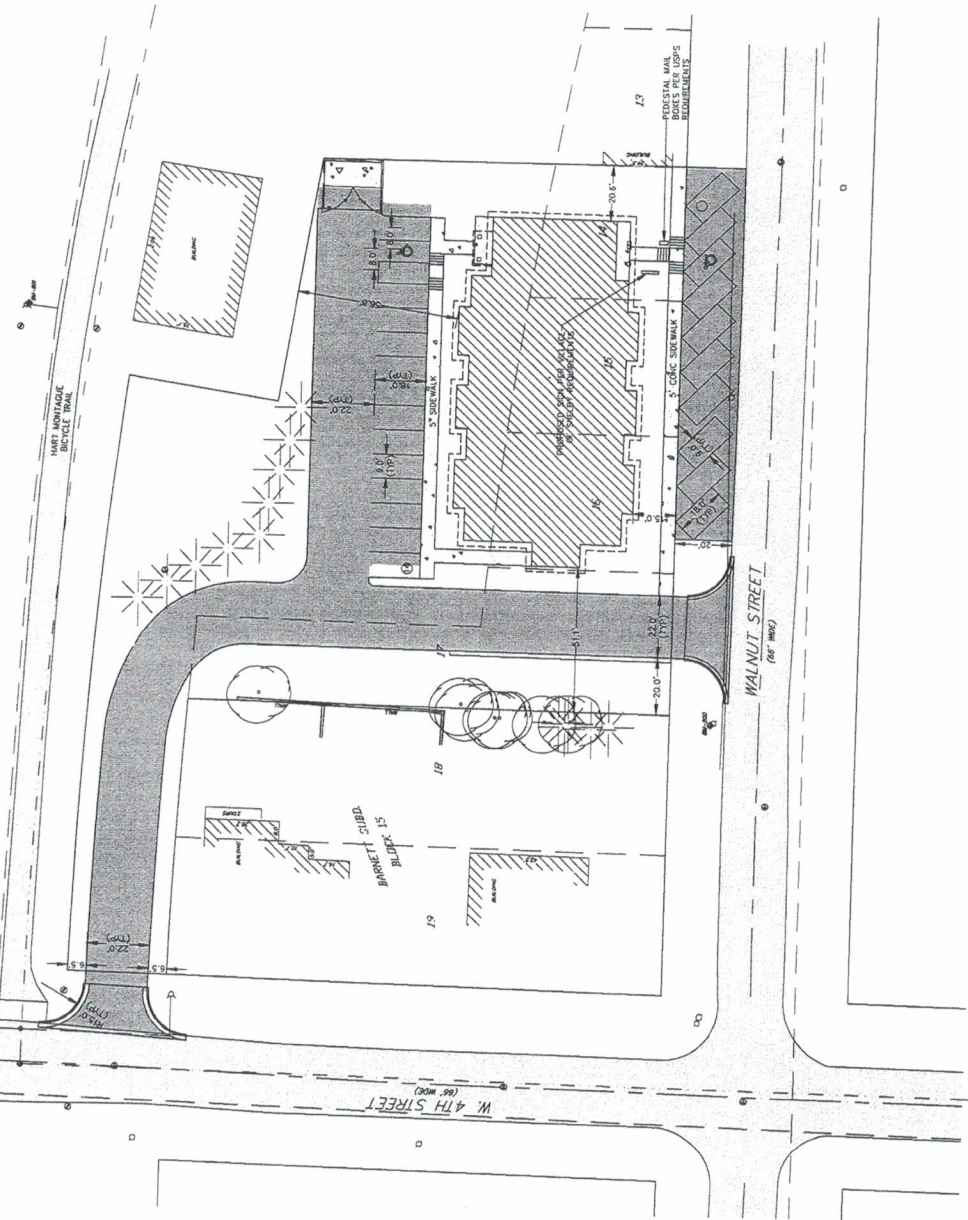
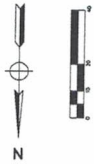

PROPOSED USE IS FOR MULTI-FAMILY HOUSING
 PROPERTY ZONING = C-1
 ADJACENT ZONING = C-1
 NO REQUIRED BUILDING SET BACKS PER ZONING
 PARKING CALCULATION
 15 UNITS @ 1.5 SPACES PER UNIT = 23 SPACES REQUIRED
 PARKING PROVIDED = 23 SPACES WITH 2 VAN ACCESSIBLE SPACES FREE

REV.	SITE PLAN REVISION DESCRIPTION	DATE
		11/7/2020

INA	INOYRINO & ASSOCIATES, INC. Providing Complete Planning & Surveying Services since 1972 1801 W. 3rd Street, Suite 100 Lincoln, NE 68502 Phone: 402-441-4444 Fax: 402-441-4445
CLIENT:	DC/ANA HOUSING COMMISSION 220 WALNUT STREET, SHELBY, MI
SCALE:	AS SHOWN
DATE:	OCTOBER 2020
JOB NUMBER:	9093-13
SHEET:	C101

TRANSPARENCY SURVEY DATED 1/24/20
 PROVIDED BY:
 BPR
 1000 W. 10th Street
 Lincoln, NE 68508
 Phone: 402-441-3800
 Fax: 402-441-3805

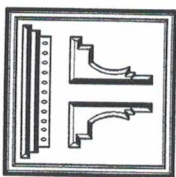

Kendra C.
THOMPSON
 architects, P.C.
 603 Cherry Street
 Columbus, Ohio 43215
 Tel: 281-723-4195
 thompson.kendra@thompsonarchitects.com
 www.kendraithompsonarchitects.com

NO.	REVISIONS / DIMENSIONS	DATE
1	DESIGN DEVELOPMENT	NOV/2020
2	DESIGN DEVELOPMENT	NOV/2020
3	SITE PLAN PLOTTED	1/11/21

PROJECT NAME
 NEW HOUSING PROJECT:
SHELBY TRAILS
 220 WALNUT STREET
 SHELBY, MICHIGAN

DRAWING TITLE
MAIN & UPPER LEVEL PLANS

DRAWN	KCT PROJECT NO.
1/CT	4-2-2020
REVIEWED	DRAWING NO.
J/CT	A202
DATE	SHEET NO.
1/11/21	497
SCALE	NO. SHEETS
AS SHOWN	1

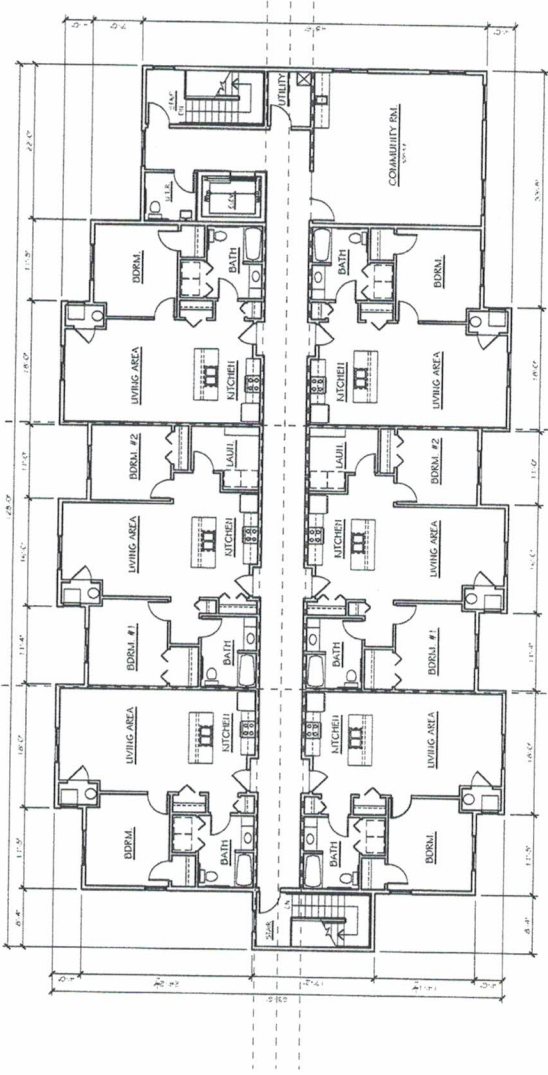

UPPER LEVEL PLAN
 SCALE: 1/8" = 1'-0"

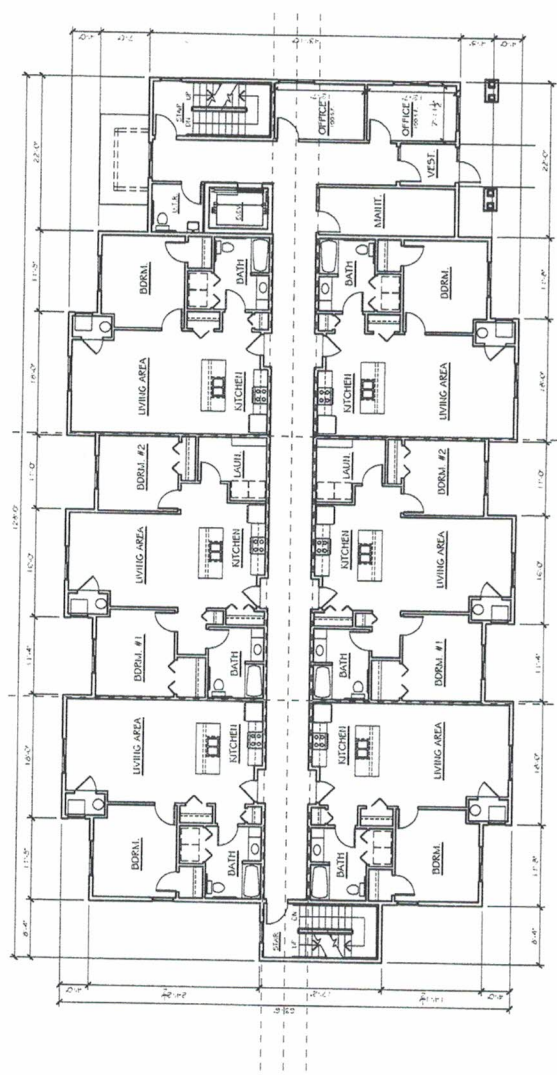

MAIN LEVEL PLAN
 SCALE: 1/8" = 1'-0"

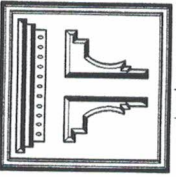

kendra c.
THOMPSON
 architects, P.C.
 803 Cherry Street
 Anneton, MD 21830
 Thompson 410-263-4195
 kthompson@thompsonarchitects.com
 www.kendratthompsonarchitects.com

NO.	REVISIONS / SUBMISSIONS	DATE
1	REVISED PER COMMENTS	11/20/2010
2	REVISED PER COMMENTS	11/20/2010
3	REVISED PER COMMENTS	11/20/2010

PROJECT NAME
 NEW HOUSING PROJECT:
SHELBY TRAILS
 255 WALNUT STREET
 SHELBY, MICHIGAN

DRAWING TITLE
UNIT PLANS

DRAWN	NET PROJECT NO.
REVISED	DRAWING NO.
DATE	A203
SCALE	SHEET NO.
1/4" = 1'-0"	5 OF 7



ONE BEDROOM
 798 sf

TWO BEDROOM
 1029 sf

UNIT PLANS
 SCALE: 1/4" = 1'-0"



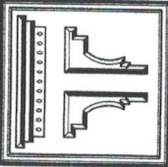

kendria c.
THOMPSON
 architects, p.c.
 803 Cherry Street
 Monroe, MI 49860
 531.725.4190
 Thompson@thompson-architects.com
 www.kendriathompson-architects.com

NO.	REVISIONS / SUBMISSIONS	DATE
1	REVISED EXTERIOR	10/20/2020
2	REVISED EXTERIOR	10/20/2020
3	REVISED EXTERIOR	10/20/2020

PROJECT NAME
NEW HOUSING PROJECT:
SHELBY TRAILS
 205 WINDLE STREET
 SHELBY, MICHIGAN

DRAWING TITLE
BUILDING ELEVATIONS

DRAWN	KCT PROJECT NO.
1-CET	11-21-2020
REVIEWED	DRAWING NO.
1-CET	A300
DATE	SHEET NO.
10/20/2020	7 OF 7
SCALE	DATE PLOTTED
1/8" = 1'-0"	10/20/2020

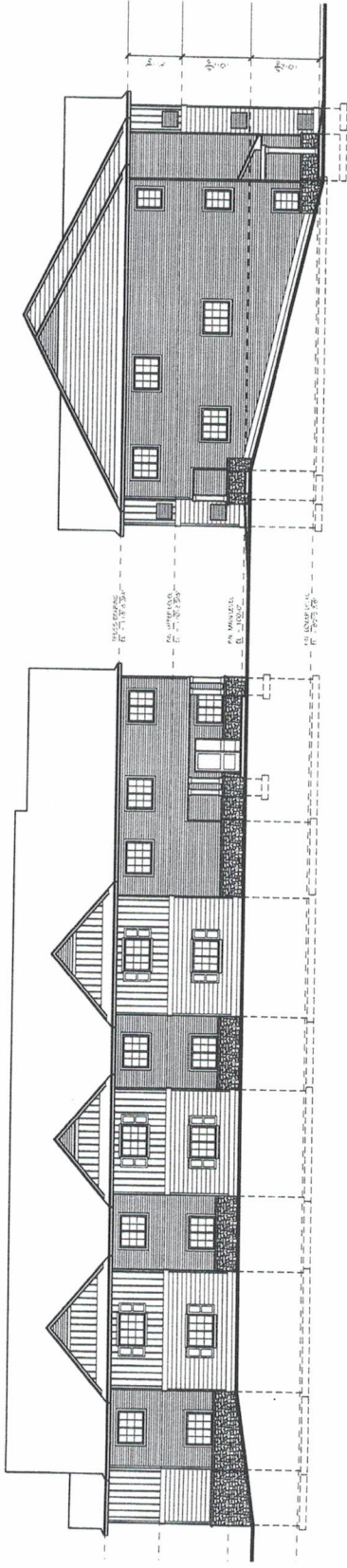

CONCEPTUAL
 SOUTH ELEVATION
 SCALE: 1/8" = 1'-0"

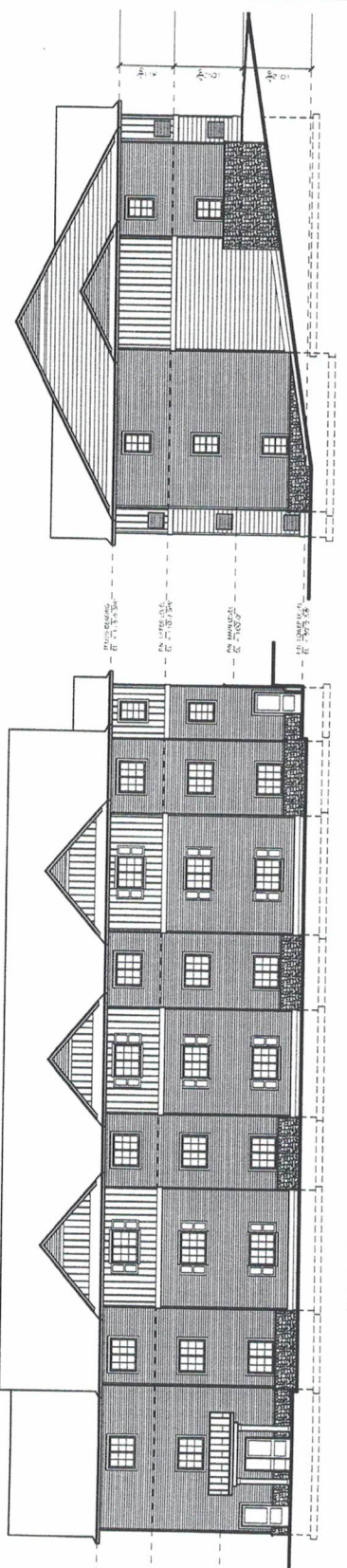

CONCEPTUAL
 NORTH ELEVATION
 SCALE: 1/8" = 1'-0"

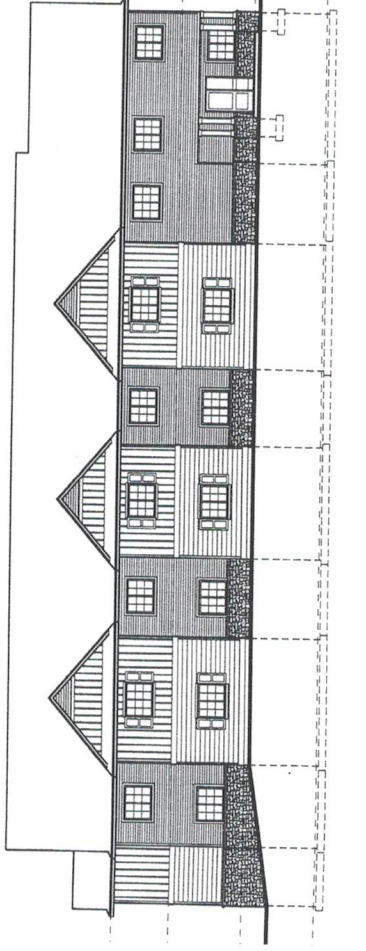

CONCEPTUAL
 WEST ELEVATION
 SCALE: 1/8" = 1'-0"

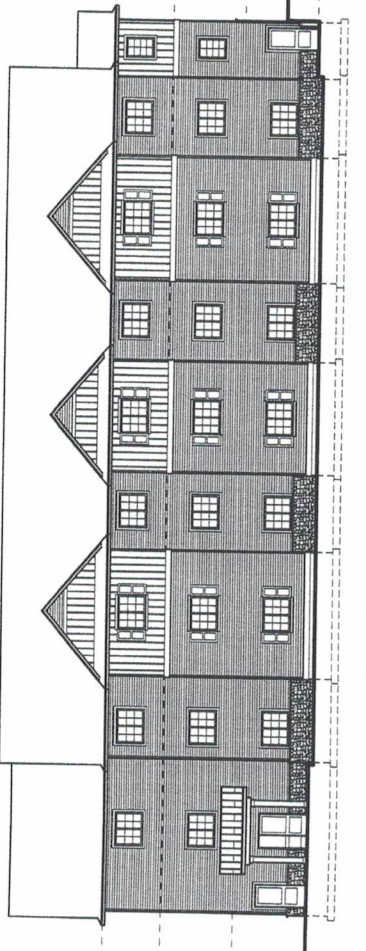

CONCEPTUAL
 EAST ELEVATION
 SCALE: 1/8" = 1'-0"



LOCATION MAP
NO SCALE

15-UNIT HOUSING PROJECT

SHELBY TRAILS

OCHC SHELBY LHDA LP
220 WALNUT STREET
SHELBY, MICHIGAN

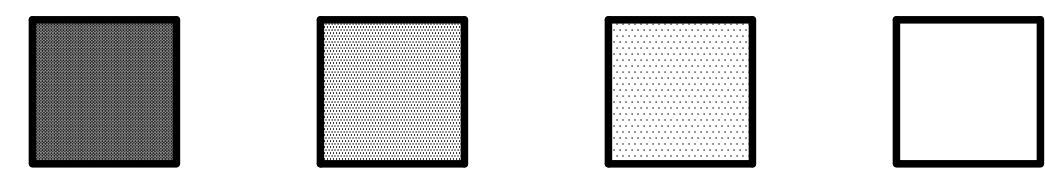

SITE PLAN REVIEW

NOVEMBER 2, 2020

RESIDENTIAL UNIT TYPES:

ONE-BEDROOM UNITS	9 STANDARD 1 BARRIER-FREE ACCESSIBLE 10 TOTAL ONE-BEDROOM UNITS
TWO-BEDROOM UNITS	4 STANDARD 1 BARRIER-FREE ACCESSIBLE 5 TOTAL TWO-BEDROOM UNITS
TOTAL UNITS:	15 RESIDENCES

SCHEDULE OF DRAWINGS:

T100	COVER SHEET
C100	EXISTING CONDITIONS
C101	PROPOSED LAYOUT PLAN
C102	PROPOSED GRADING & UTILITY PLAN
C103	DETAIL SHEET
A201	PROPOSED LOWER LEVEL PLAN
A202	PROPOSED MAIN LEVEL & UPPER LEVEL PLANS
A203	PROPOSED UNIT PLANS
A300	BUILDING ELEVATIONS



MECH./ELEC./PLB'G. ENGINEER:

Nealis Engineering
830 Cottageview Drive
Suite 102
Traverse City, MI 49684
t: 231.933.0510

CIVIL ENGINEER:

Spicer Group
302 River Street
Manistee, MI 49660
t: 231.794.5620

PROJECT TEAM

ARCHITECT:

Kendra C. Thompson
Architects, P.C.
803 Cherry Street
Manistee, MI 49660
t: 231.723.4195

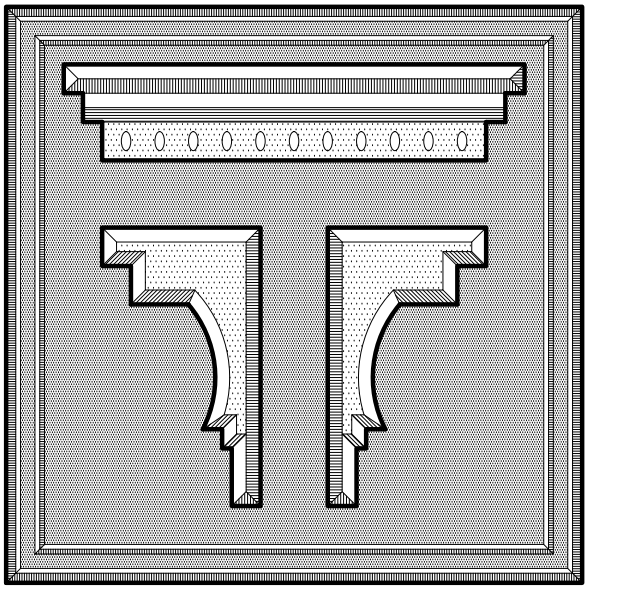

kendra c.
THOMPSON
architects, p.c.
803 Cherry Street
Manistee, MI 49660
tel: 231.723.4195
thompson.kendra@sbcglobal.net
www.kendraithompson-architects.com

NO.	REVISIONS / SUBMISSIONS	DATE
3	SITE PLAN REVIEW	11/2/2020
2	DESIGN DEVELOPMENT	10/29/2020
1	DESIGN DEVELOPMENT	10/24/2020

PROJECT NAME		
NEW HOUSING PROJECT: SHELBY TRAILS 220 WALNUT STREET SHELBY, MICHIGAN		
DRAWING TITLE		
COVER		
SEAL	DRAWN KCT	KCT PROJECT NO. KT-21902G
	REVIEWED KCT	DRAWING NO. T100
	DATE DEC 2019	SHEET NO.
	SCALE AS NOTED	1 OF 7

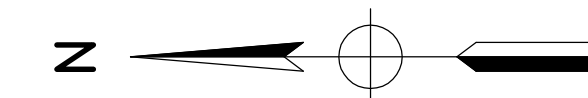

SCALE: 1" = 20'
Contour Interval = 1 foot

LEGEND

- - MANHOLE
- ⊙ - CATCHBASIN
- ⊠ - CURB CATCHBASIN
- ⊕ - FIRE HYDRANT
- ⊗ - WATER VALVE
- ⊛ - TELEPHONE POLE
- ⊙ - LIGHT POLE
- ⊠ - MAIL BOX
- ⊠ - SIGN
- ⊠ - TRANSFORMER
- ⊠ - BARRIER FREE PARKING
- ▨ - BITUMINOUS SURFACE
- ▨ - CONCRETE SURFACE
- ▨ - CONCRETE CURB
- — — - OVERHEAD POWER LINES
- — — - TREE LINE
- — — - STUMP
- ⊙ - PINE
- ⊙ - BUSH
- ⊙ - TREE
- ⊙ - TELEPHONE PEDESTAL
- ⊙ - FOUND SURVEY CORNER
- ⊙ - BENCH MARK
- — — - SANITARY SEWER LINES
- — — - STORM SEWER LINES
- — — - WATERMAINS

EXISTING SANITARY SCHEDULE
 SAN MH#1
 RIM = 817.20
 8" VCP N INV = 808.48
 8" VCP S INV = 810.03
 8" VCP W INV = 808.73

SAN MH#2
 RIM = 824.38
 8" VCP N INV = 817.43

SAN MH#3
 RIM = 820.37
 8" VCP S INV = 807.97
 8" VCP W INV = 810.77

SAN MH#4
 RIM = 811.33
 8" VCP E INV = 805.43

SAN MH#5
 RIM = 803.49
 8" VCP E INV = 794.59
 8" VCP S INV = 794.74
 8" VCP W INV = 796.59

SAN MH#6
 RIM = 805.43
 8" VCP N INV = 797.08

SAN MH#7
 RIM = 803.02
 12" VCP N INV = 793.42
 6" VCP SE INV = 798.47
 12" VCP SSE INV = 795.22
 8" VCP W INV = 793.67

EXISTING STORM SCHEDULE
 CB#1
 RIM = 802.83
 12" CONC INV = 796.83
 (PIPE AT BOTTOM DROPS INTO MAINLINE)

CB#2
 RIM = 802.07
 FILLED WITH SNOW AND DEBRIS

CB#3
 RIM = 802.00
 36" CONC N INV = 796.40
 36" CONC S INV = 796.50

CB#4
 RIM = 805.43
 36" CONC NNE INV = 796.83
 15" CMP E INV = 800.88
 24" CONC SSW INV = 796.93

CB#5
 RIM = 805.49
 15" CMP W INV = 801.44
 12" CONC S INV = 801.64

BENCHMARKS

- BM #200 - SET 60D SPIKE ON NE POWER POLE. NAVD88 EL. 825.70
- BM #201 - PAINTED "X" ON TOP OF BOLT ON S.W. SIDE OF HYDRANT. NAVD88 EL. 807.32

UTILITY NOTE

The utility locations as hereon shown are based on field observations. However, it is not possible to determine the precise location and depth of underground utilities without excavation. Therefore, we cannot guarantee the accuracy or completeness of the buried utility information hereon shown. The contractor shall call "MISS DIG" (1-800-482-7171 or 811) within three working days prior to any excavation. The contractor is responsible for verifying these utility locations prior to construction and shall make every effort to protect and/or relocate them as required. The contractor shall notify the Engineer/Surveyor as soon as possible in the event a discrepancy is found.

LEGAL DESCRIPTION

LOTS 14, 15, 16 AND 17, BLOCK 15, VILLAGE OF BARNETT, ACCORDING TO THE RECORDED PLAT THEREOF, VILLAGE OF SHELBY, OCEANA COUNTY, MICHIGAN

AND

PART OF THE ABANDONED RAILROAD RIGHT OF WAY, IN THE PLAT OF THE VILLAGE OF BARNETT, VILLAGE OF SHELBY, OCEANA COUNTY, MICHIGAN, DESCRIBED AS BEGINNING AT THE SOUTHEAST CORNER OF LOT 14, BLOCK 15 IN SAID VILLAGE OF BARNETT PLAT; THENCE 172.33 FEET ALONG A CURVE TO THE LEFT, SAID CURVE HAVING A RADIUS OF 2225.99 FEET AND IS SUBTENDED BY A CHORD WHICH BEARS N08°02'24"E, 172.29 FEET; THENCE S88°54'25"E, 135.22 FEET TO A POINT ON A CURVE; THENCE ALONG SAID CURVE TO THE RIGHT 87.41 FEET SAID CURVE HAVING A RADIUS OF 2360.78 FEET AND SUBTENDED BY A CHORD WHICH BEARS S06°36'44"E A DISTANCE OF 87.41 FEET; THENCE N80°39'25"W, 53.40 FEET; THENCE S09°18'24"W, 91.62 FEET; THENCE N89°36'49"W, 81.73 FEET TO THE POINT OF BEGINNING, CONTAINING 0.42 ACRE OF LAND, MORE OR LESS, AND SUBJECT TO ANY EASEMENTS OF RECORD.

EASEMENT DESCRIPTION:

PART OF THE ABANDONED RAILROAD RIGHT OF WAY, IN THE PLAT OF THE VILLAGE OF BARNETT, VILLAGE OF SHELBY, OCEANA COUNTY, MICHIGAN DESCRIBED AS BEGINNING AT THE NORTHEAST CORNER OF LOT 19, BLOCK 15 OF SAID VILLAGE OF BARNETT; THENCE S88°36'15"E, 34.94 FEET TO A POINT ON A CURVE; THENCE ALONG SAID CURVE TO THE RIGHT A DISTANCE OF 127.75 FEET, SAID ARC HAVING A RADIUS OF 2360.78 FEET AND SUBTENDED BY A CHORD WHICH BEARS S04°00'04"W A DISTANCE OF 127.73 FEET; THENCE N88°54'25"W, 35.04 FEET TO A POINT ON A CURVE; THENCE ALONG SAID CURVE TO THE LEFT A DISTANCE OF 127.94 FEET, SAID ARC HAVING A RADIUS OF 2325.78 FEET AND SUBTENDED BY A CHORD WHICH BEARS N04°02'32"E A DISTANCE OF 127.92 FEET TO THE POINT OF BEGINNING, CONTAINING 0.10 ACRE OF LAND, MORE OR LESS.

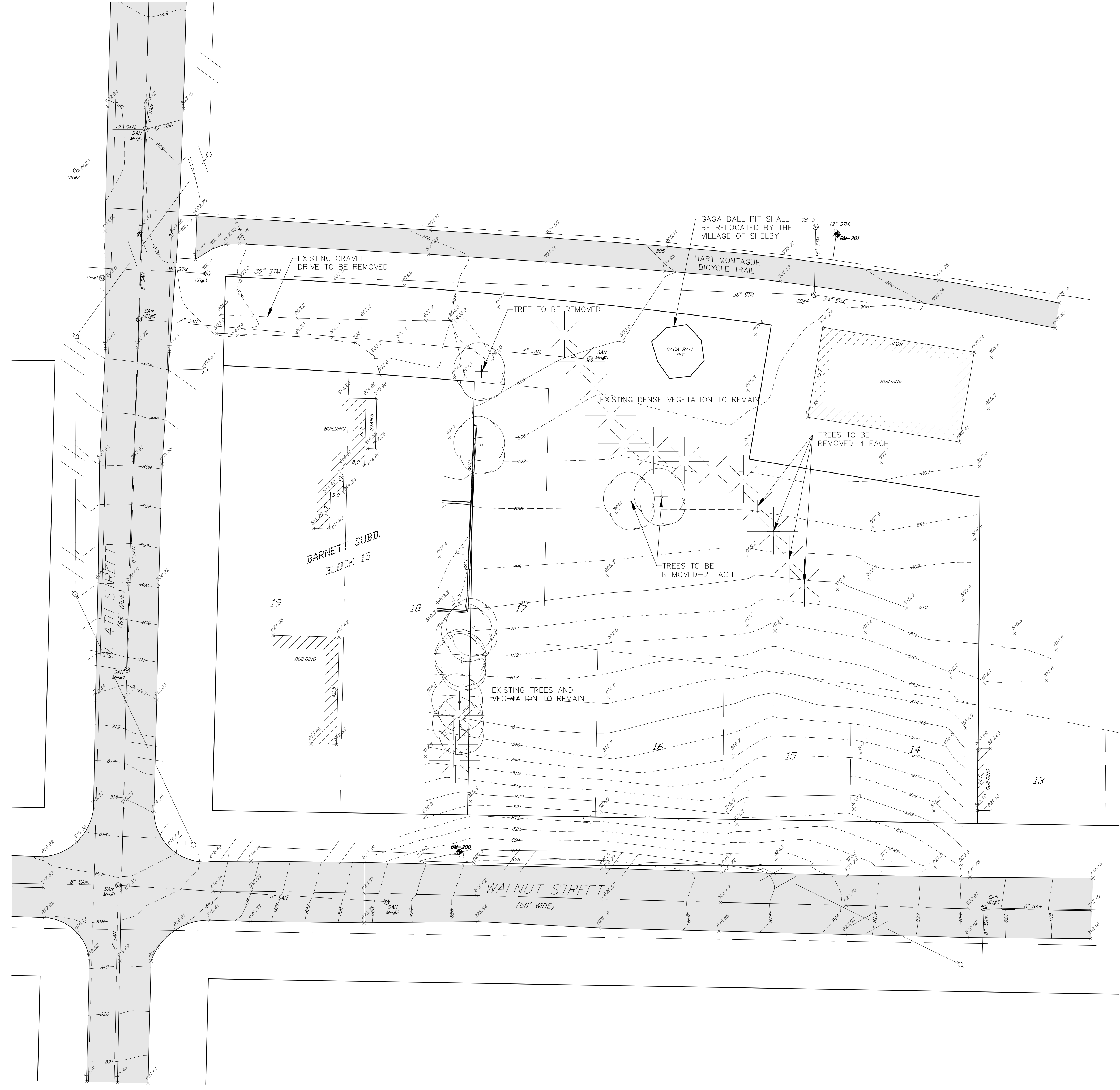

TOPOGRAPHIC SURVEY DATED 1/24/20
 PROVIDED BY:



MANISTEE OFFICE
 302 River Street
 Manistee, MI 49660
 Tel. 231-794-5620
 www.SpicerGroup.com

REV.	SITE PLAN REVIEW DESCRIPTION	DATE
		11/2/2020

Providing Complete Engineering & Surveying Services since 1972	NORDLUND & ASSOCIATES, INC. 813 E. Ludington Ave. 267 River Street Ludington, MI 49431 Manistee, MI 49660 (231) 843-3485 (231) 723-6460 FAX: (231) 843-7676	
	CLIENT: OCEANA HOUSING COMMISSION 15 UNIT HOUSING PROJECT 220 WALNUT STREET, SHELBY, MI	DRAWN BY: HM SCALE: AS SHOWN DATE: OCTOBER 2020
DESCRIPTION: EXISTING CONDITIONS	JOB NUMBER XXX-X	SHEET C100

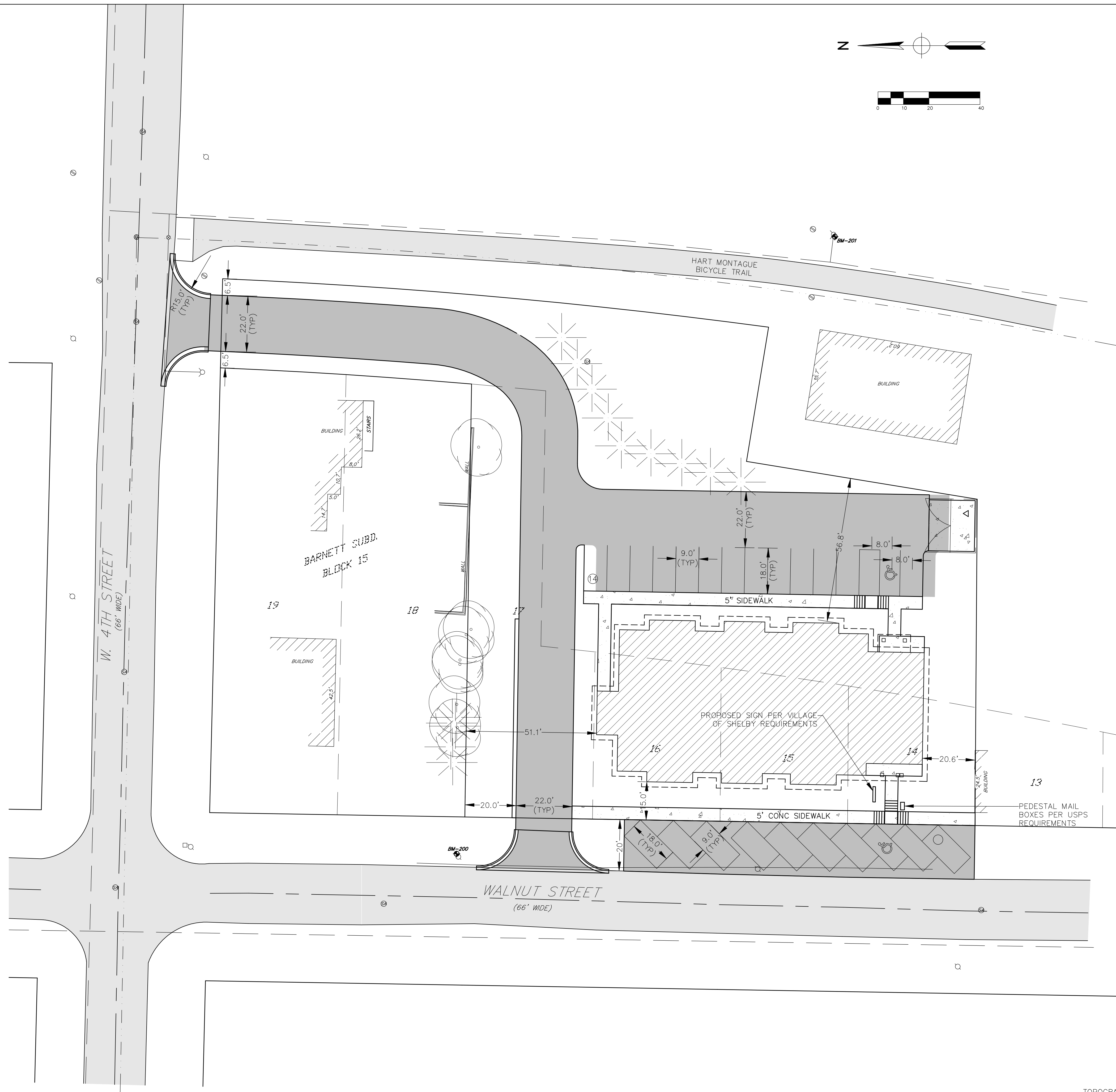
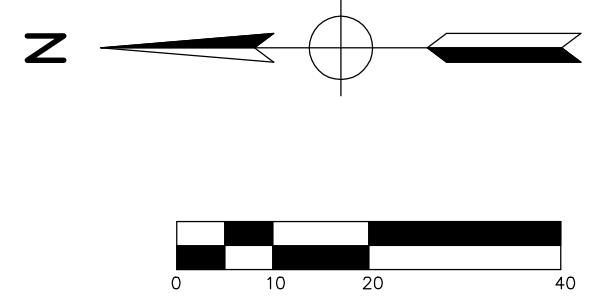

PROPOSED USE IS FOR MULTI FAMILY HOUSING
 PROPERTY ZONING = C-1
 ADJACENT ZONING = C-1
 NO REQUIRED BUILDING SET BACKS PER ZONING
 PARKING CALCULATION
 15 UNITS @ 1.5 SPACES PER UNIT = 23 SPACES REQUIRED
 PARKING PROVIDED = 23 SPACE WITH 2 VAN ACCESSIBLE BARRIER FREE

TOPOGRAPHIC SURVEY DATED 1/24/20
 PROVIDED BY:
Spicer group
 MANISTEE OFFICE
 302 River Street
 Manistee, MI 49660
 Tel. 231-794-5620
 www.SpicerGroup.com

REV.	SITE PLAN REVIEW	11/2/2020
	DESCRIPTION	DATE
Providing Complete Engineering & Surveying Services since 1972		NORDLUND & ASSOCIATES, INC. 813 E. Ludington Ave. 267 River Street Ludington, MI 49431 Manistee, MI 49660 (231) 843-3485 (231) 723-6460 FAX: (231) 843-7676
CLIENT:	OCEANA HOUSING COMMISSION 15 UNIT HOUSING PROJECT 220 WALNUT STREET, SHELBY, MI	DRAWN BY: HM CHECKED BY: HM
		SCALE: AS SHOWN
		DATE: OCTOBER 2020
DESCRIPTION:	PROPOSED LAYOUT PLAN	JOB NUMBER SHEET
		9093-13 C101

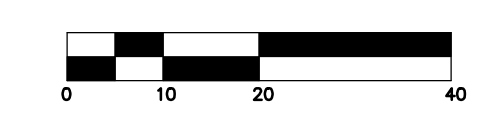
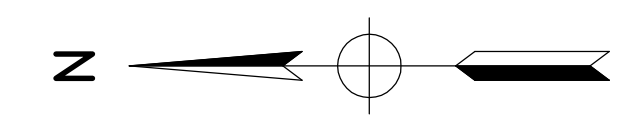

SCALE: 1" = 20'
Contour Interval = 1 foot

LEGEND

- - MANHOLE
- ⊙ - CATCHBASIN
- ⊠ - CURB CATCHBASIN
- ⊕ - FIRE HYDRANT
- ⊗ - WATER VALVE
- ⊘ - TELEPHONE POLE
- ⊙ - LIGHT POLE
- ⊠ - MAIL BOX
- ⊠ - SIGN
- ⊠ - TRANSFORMER
- ⊠ - BARRIER FREE PARKING
- ▭ - BITUMINOUS SURFACE
- ▭ - CONCRETE SURFACE
- ▭ - CONCRETE CURB
- — — — — OVERHEAD POWER LINES
- — — — — TREE LINE
- — — — — STUMP
- ⊙ - PINE
- ⊙ - BUSH
- ⊙ - TREE
- ⊙ - TELEPHONE PEDESTAL
- ⊙ - FOUND SURVEY CORNER
- ⊙ - BENCH MARK
- — — — — SANITARY SEWER LINES
- — — — — STORM SEWER LINES
- — — — — WATERMANS

EXISTING SANITARY SCHEDULE
 SAN MH#1
 RIM = 817.20
 8" VCP N INV = 808.48
 8" VCP S INV = 810.03
 8" VCP W INV = 808.73

SAN MH#2
 RIM = 824.38
 8" VCP N INV = 817.43

SAN MH#3
 RIM = 820.37
 8" VCP S INV = 807.97
 8" VCP W INV = 810.77

SAN MH#4
 RIM = 811.33
 8" VCP E INV = 805.43

SAN MH#5
 RIM = 803.49
 8" VCP E INV = 794.59
 8" VCP S INV = 794.74
 8" VCP W INV = 796.59

SAN MH#6
 RIM = 805.43
 8" VCP N INV = 797.08

SAN MH#7
 RIM = 803.02
 12" VCP N INV = 793.42
 6" VCP SE INV = 798.47
 12" VCP SSE INV = 795.22
 8" VCP W INV = 793.67

EXISTING STORM SCHEDULE
 CB#1
 RIM = 802.83
 12" CONC INV = 796.83
 (PIPE AT BOTTOM DROPS INTO MAINLINE)

CB#2
 RIM = 802.07
 FILLED WITH SNOW AND DEBRIS

CB#3
 RIM = 802.00
 36" CONC N INV = 796.40
 36" CONC S INV = 796.50

CB#4
 RIM = 805.43
 36" CONC NNE INV = 796.83
 15" CMP E INV = 800.88
 24" CONC SSW INV = 796.93

CB#5
 RIM = 805.49
 15" CMP W INV = 801.44
 12" CONC S INV = 801.64

PROPOSED STORM SCHEDULE
 ST-1
 2' DIA CB
 RIM = 808.40
 12" N INV = 805.40

ST-2
 4' DIA CB
 RIM = 810.25
 12" S INV = 804.89
 12" E INV = 802.21

ST-3
 4' DIA CB
 RIM = 803.58
 12" S INV = 800.58

ST-4
 4' DIA CB
 RIM = 804.50
 12" W INV = 801.50
 12" N INV = 800.19
 CONNECT TO EX 36" INV

BENCHMARKS

- BM #200 - SET 60D SPIKE ON NE POWER POLE. NAVD88 EL. 825.70
- BM #201 - PAINTED "X" ON TOP OF BOLT ON S.W. SIDE OF HYDRANT. NAVD88 EL. 807.32

UTILITY NOTE

The utility locations as hereon shown are based on field observations. However, it is not possible to determine the precise location and depth of underground utilities without excavation. Therefore, we cannot guarantee the accuracy or completeness of the buried utility information hereon shown. The contractor shall call "MISS DIG" (1-800-482-7171 or 811) within three working days prior to any excavation. The contractor is responsible for verifying these utility locations prior to construction and shall make every effort to protect and/or relocate them as required. The contractor shall notify the Engineer/Surveyor as soon as possible in the event a discrepancy is found.

16 GAS METERS AND 16 ELECTRICAL METERS TO BE INSTALLED—LOCATION SHALL BE COORDINATED WITH UTILITY COMPANIES

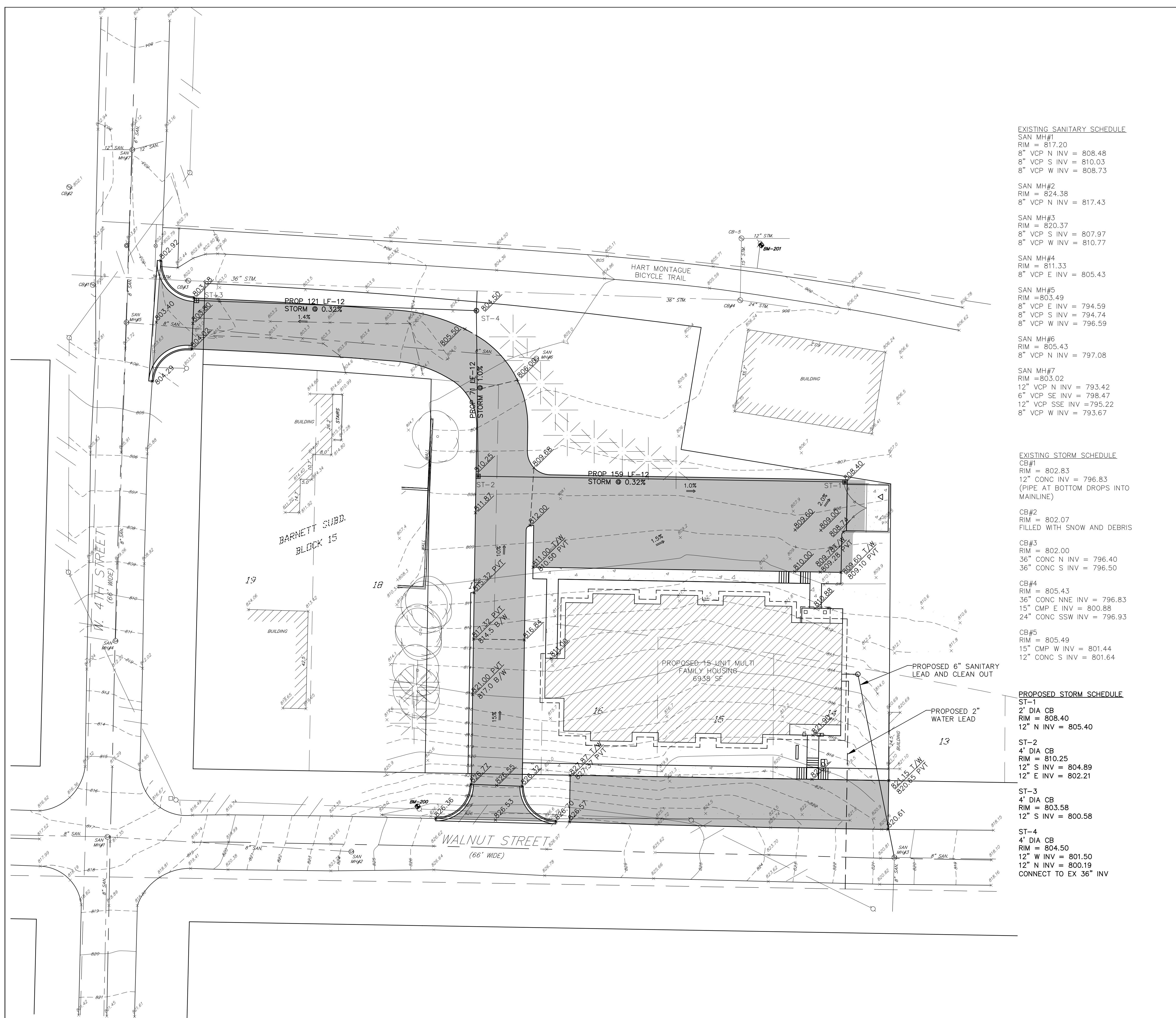

REV.	SITE PLAN REVIEW	11/2/2020
	DESCRIPTION	DATE
Providing Complete Engineering & Surveying Services since 1972		NORDLUND & ASSOCIATES, INC. 813 E. Ludington Ave. 267 River Street Ludington, MI 49431 Manistee, MI 49660 (231) 843-3485 (231) 723-6460 FAX: (231) 843-7676
CLIENT:	OCEANA HOUSING COMMISSION 15 UNIT HOUSING PROJECT 220 WALNUT STREET, SHELBY, MI	DRAWN BY: HM CHECKED BY: HM
DESCRIPTION:	PROPOSED GRADING & UTILITY PLAN	SCALE: AS SHOWN DATE: OCTOBER 2020
	JOB NUMBER	SHEET
	9093-13	C102

BITUMINOUS MIXTURE REQUIREMENTS	
HEAVY DUTY BITUMINOUS PAVEMENT SHALL BE USED IN THE DRIVING LANES OF THE PARKING AREA. HEAVY DUTY BITUMINOUS PAVEMENT SHALL HAVE THE FOLLOWING CROSS SECTION:	
12" MDT CLASS II SAND COMPACTED TO 95% MOD. PROCTOR DENSITY	
6" MDT 22A GRAVEL COMPACTED TO 98% MOD. PROCTOR DENSITY	
1.5" MDT HMA 13A COMPACTED TO 95-98% MOD. PROCTOR DENSITY	
1.5" MDT HMA 13A COMPACTED TO 95-98% MOD. PROCTOR DENSITY	
LIGHT DUTY BITUMINOUS PAVEMENT SHALL BE USED IN THE PARKING LANES. LIGHT DUTY BITUMINOUS PAVEMENT SHALL HAVE THE FOLLOWING CROSS SECTION:	
12" MDT CLASS II SAND COMPACTED TO 95% MOD. PROCTOR DENSITY	
6" MDT 22A GRAVEL COMPACTED TO 98% MOD. PROCTOR DENSITY	
2" MDT HMA 13A COMPACTED TO 95-98% MOD. PROCTOR DENSITY	

CONCRETE COMPRESSIVE STRENGTH SHALL BE 3,500 PSI IN 28 DAYS.

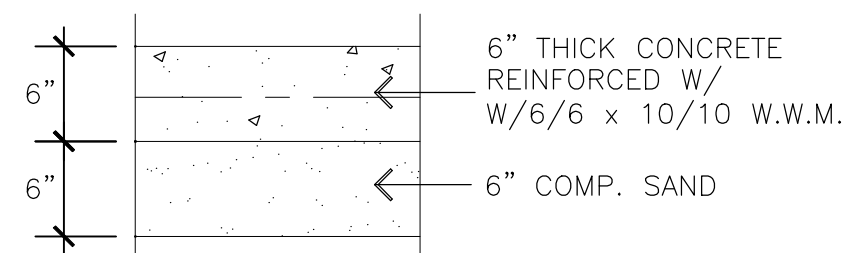

DUMPSTER PAD BASE
NOT TO SCALE

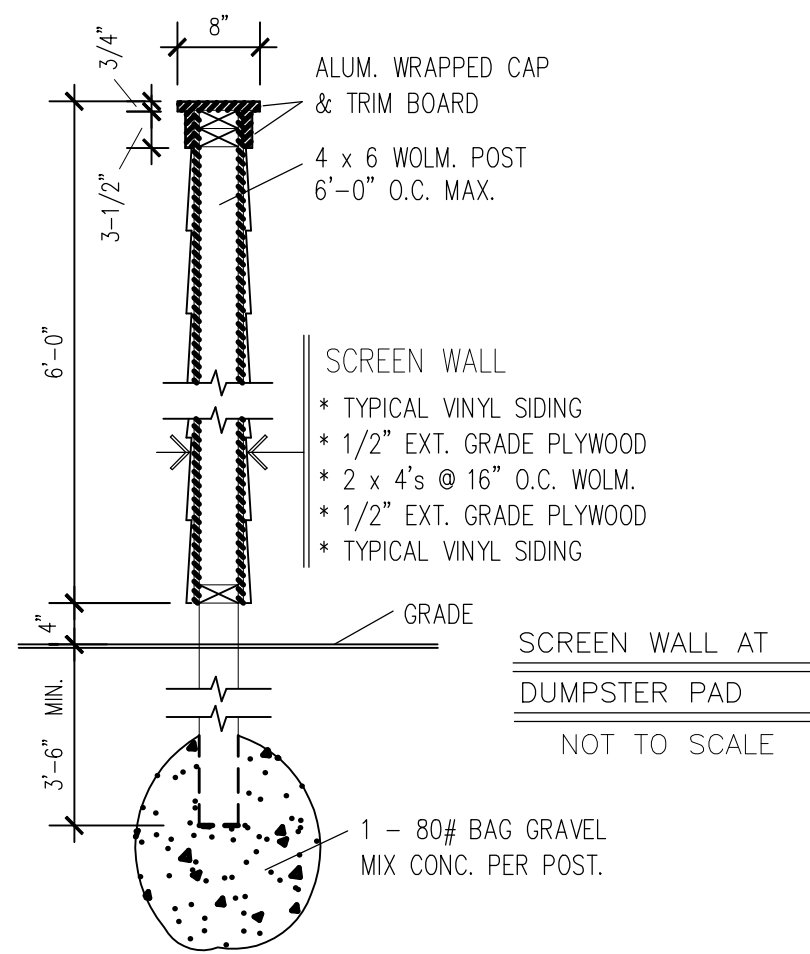

SCREEN WALL AT
DUMPSTER PAD
NOT TO SCALE

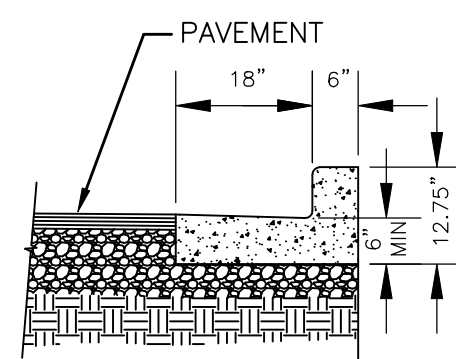

CONCRETE CURB
& GUTTER DETAIL
NOT TO SCALE

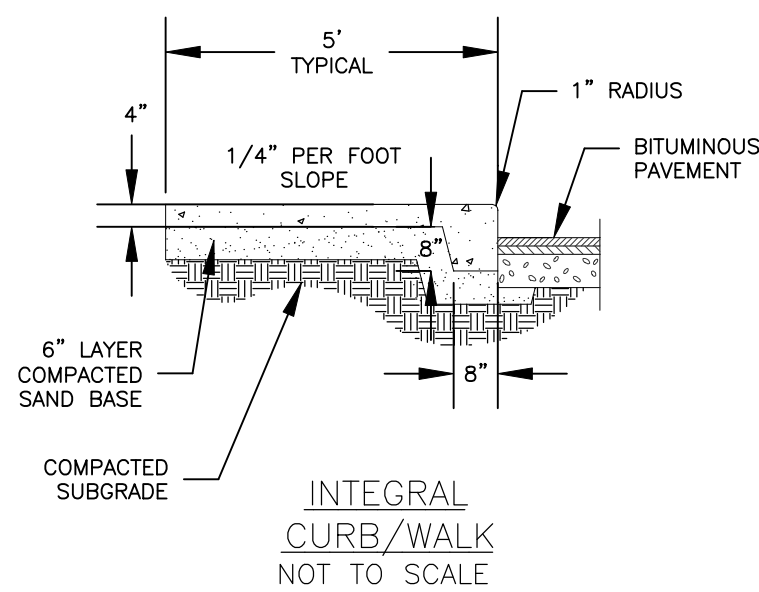

INTEGRAL
CURB/WALK
NOT TO SCALE

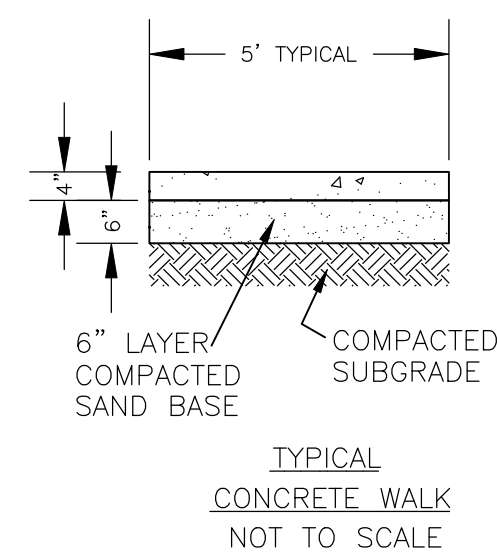

TYPICAL
CONCRETE WALK
NOT TO SCALE

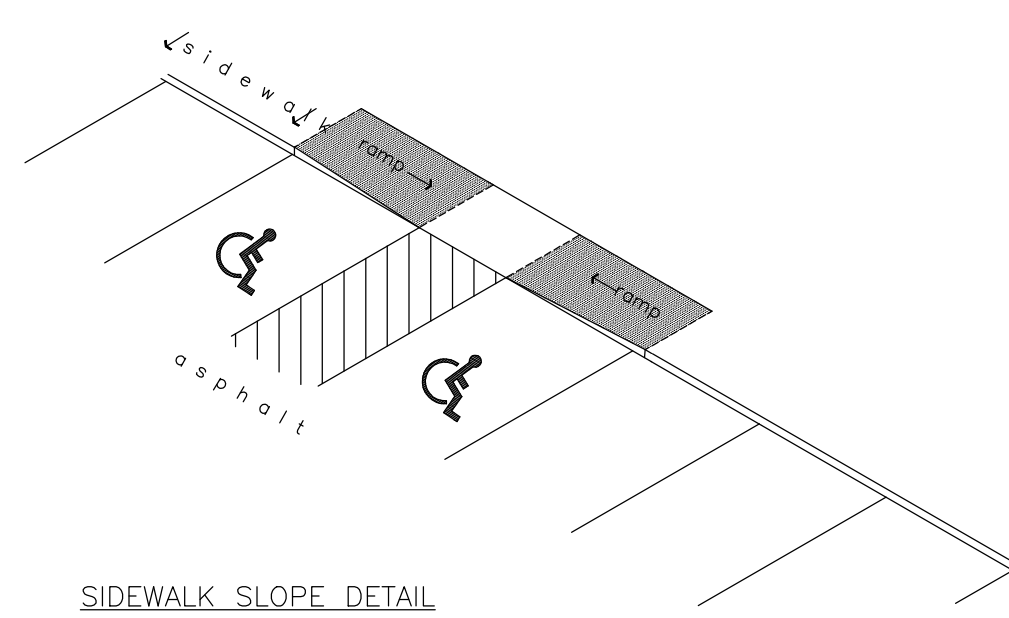

SIDEWALK SLOPE DETAIL

SITE ACCESSIBILITY DETAIL NOTES:

- REFER TO THE SITE PLAN FOR EXACT LOCATION OF BARRIER FREE PARKING, WALKWAYS AND RAMPS.
- ALL WALKWAYS, RAMPS AND BARRIER FREE PARKING SIGNAGE, ETC. SHALL MEET APPROVED "AMERICANS WITH DISABILITIES ACT" (ADA) STANDARDS AND LOCAL ACCESSIBILITY CODE.
- ONE OUT OF EVERY EIGHT (8) ACCESSIBLE PARKING SPACES, BUT NOT LESS THAN, IS REQUIRED TO BE VAN ACCESSIBLE.
- FINISHED GRADES OF PAVEMENT IN BARRIER FREE PARKING & ACCESSIBILITY AISLE SHALL NOT EXCEED 1:50 (2%) SLOPE IN ANY DIRECTION.
- ALL CONCRETE ACCESSIBLE RAMP SURFACES SHALL HAVE TRUNCATED DOMES PER ADA STANDARDS AND LOCAL ACCESSIBILITY CODE.
- ALL CONCRETE ACCESSIBLE RAMPS SHALL BE COLOR IMPREGNATED TO PROVIDE VISUAL CONTRAST (DARK TO LIGHT) WITH ADJACENT CONCRETE SURFACES.
- THE MATERIAL USED TO PROVIDE COLOR CONTRAST IS CONCRETE ACCESSIBLE RAMPLS SHALL BE AN INTEGRAL PART OF THE CONCRETE AND SHALL NOT BE PAINTED ON OR CAPABLE OF FADING OR WEARING OFF.

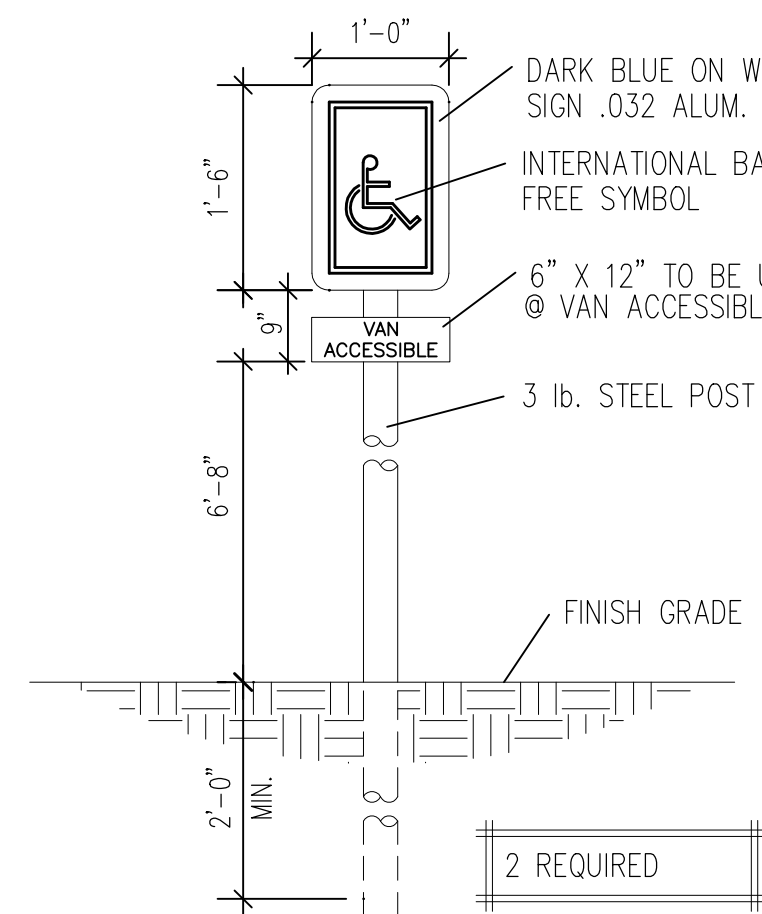

ACCESSIBLE SIGNAGE
NOT TO SCALE

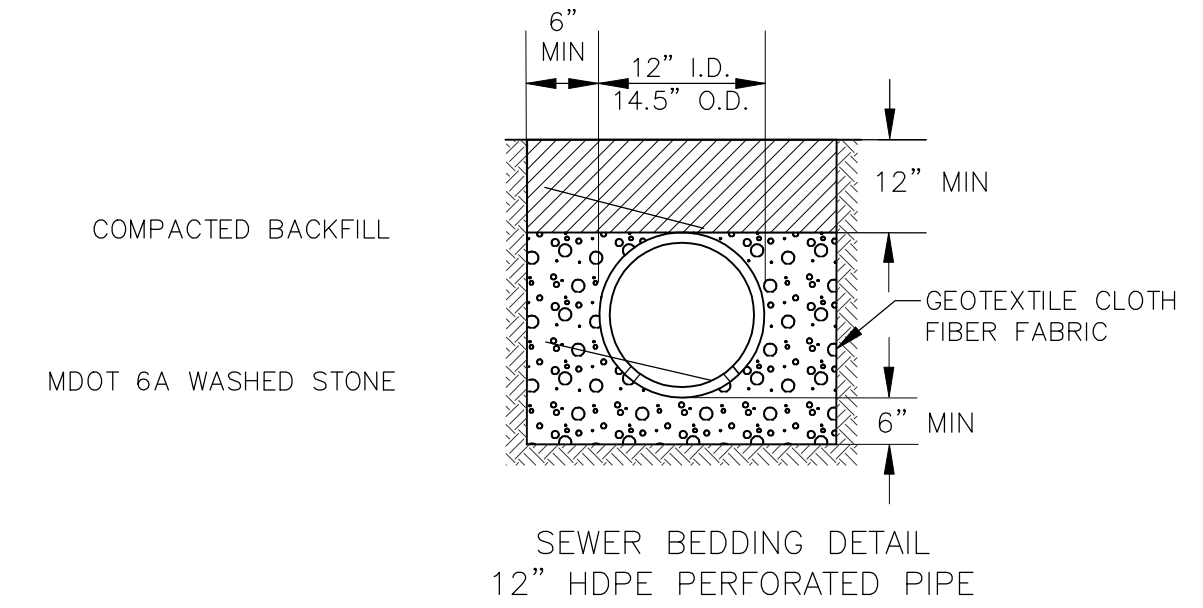

SEWER BEDDING DETAIL
12" HDPE PERFORATED PIPE

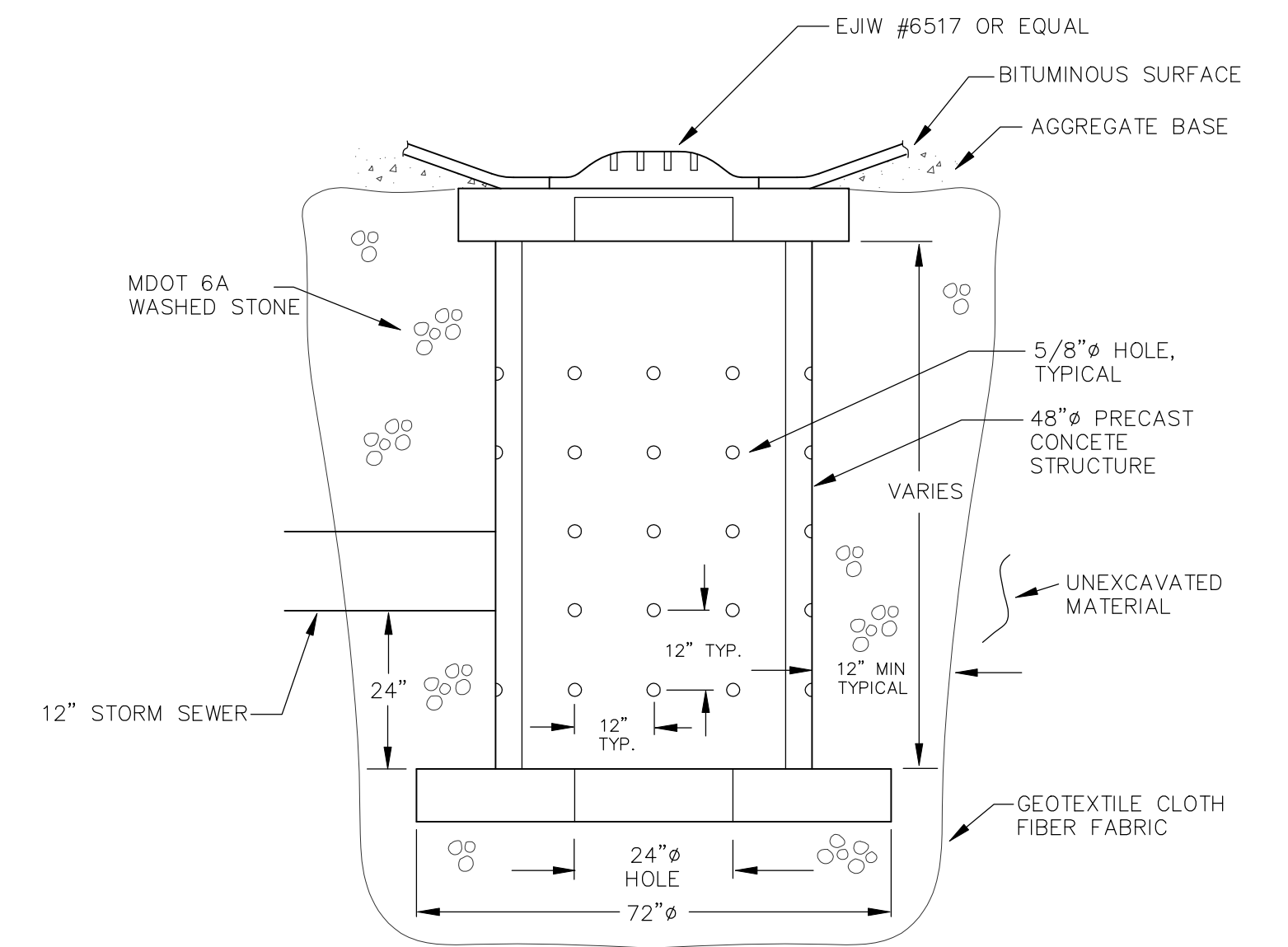

LEACHING BASIN DETAIL
NOT TO SCALE

SITE PLAN REVIEW		11/2/2020	
REV.	DESCRIPTION	BY	DATE
Providing Complete Engineering & Surveying Services since 1972		NORDLUND & ASSOCIATES, INC. 813 E. Ludington Ave. 267 River Street Ludington, MI 49431 Manistee, MI 49660 (231) 843-3485 (231) 723-6460 FAX: (231) 843-7676	
CLIENT: OCEANA HOUSING COMMISSION 15 UNIT HOUSING PROJECT 220 WALNUT STREET, SHELBY, MI		DRAWN BY: HM	CHECKED BY: HM
		SCALE: AS SHOWN	
		DATE: OCTOBER 2020	
DESCRIPTION: DETAIL SHEET		JOB NUMBER: 9093-13	SHEET: C104

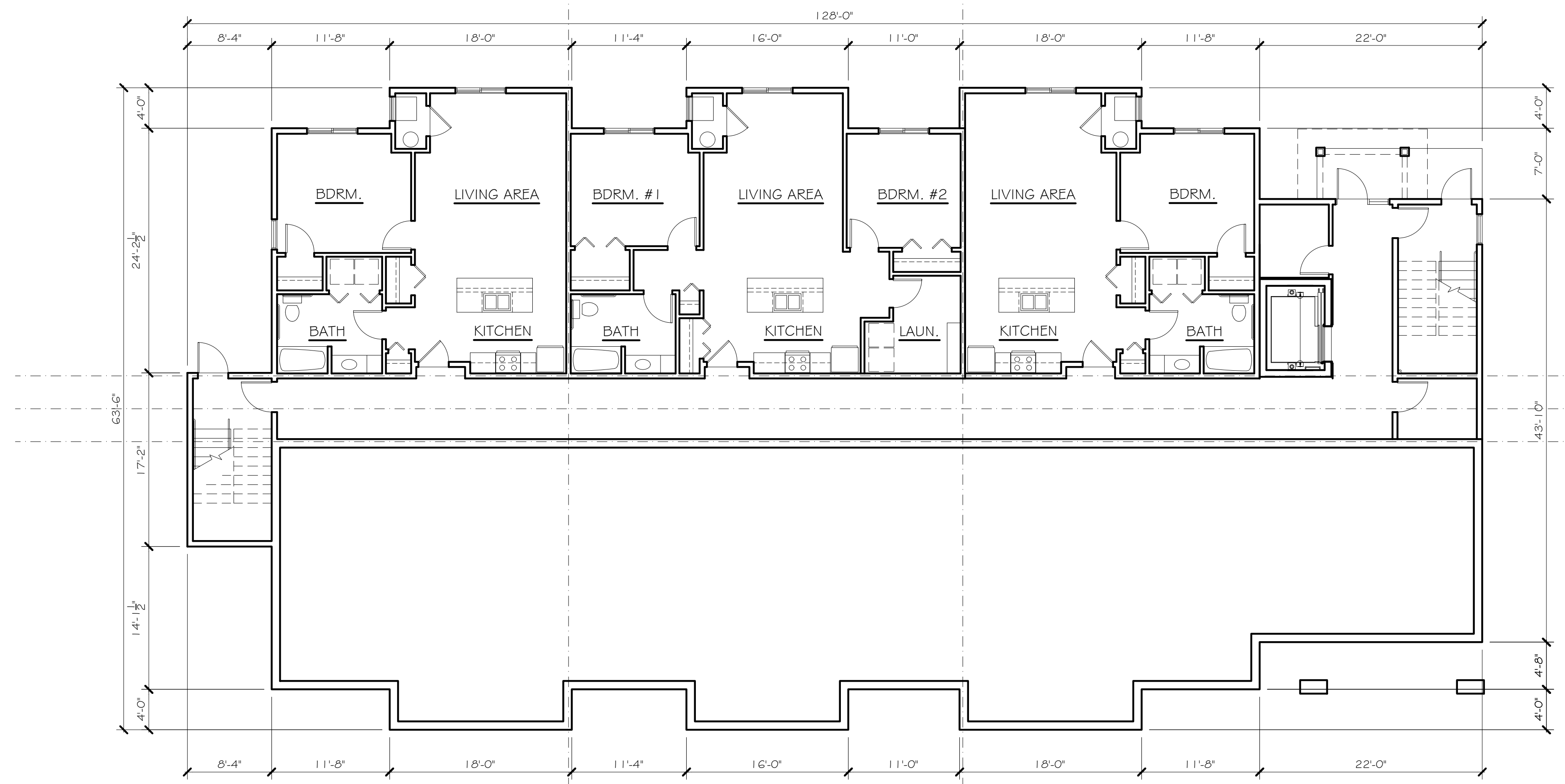

LOWER LEVEL PLAN

SCALE: 1/8" = 1'-0"

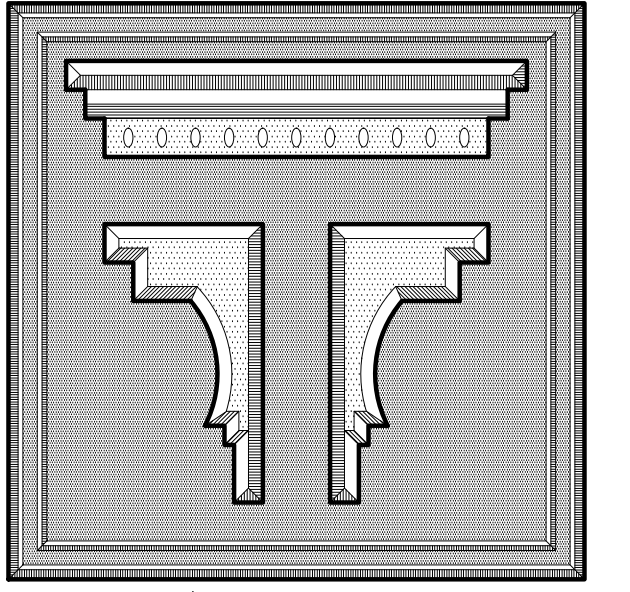
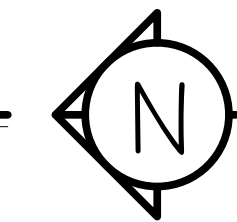

kendra c.
THOMPSON
 architects, p.c.
 803 Cherry Street
 Manistee, MI 49660
 tel: 231.723.4195
 thompson.kendra@sbcglobal.net
 www.kendraithompson-architects.com

NO.	REVISIONS / SUBMISSIONS	DATE
3	SITE PLAN REVIEW	11/2/2020
2	DESIGN DEVELOPMENT	10/29/2020
1	DESIGN DEVELOPMENT	10/24/2020

PROJECT NAME
 NEW HOUSING PROJECT:
SHELBY TRAILS
 220 WALNUT STREET
 SHELBY, MICHIGAN

DRAWING TITLE
LOWER LEVEL PLAN

SEAL	DRAWN KCT	KCT PROJECT NO. KT-219026
	REVIEWED KCT	DRAWING NO. A201
	DATE DEC 2019	SHEET NO.
	SCALE AS NOTED	3 OF 7

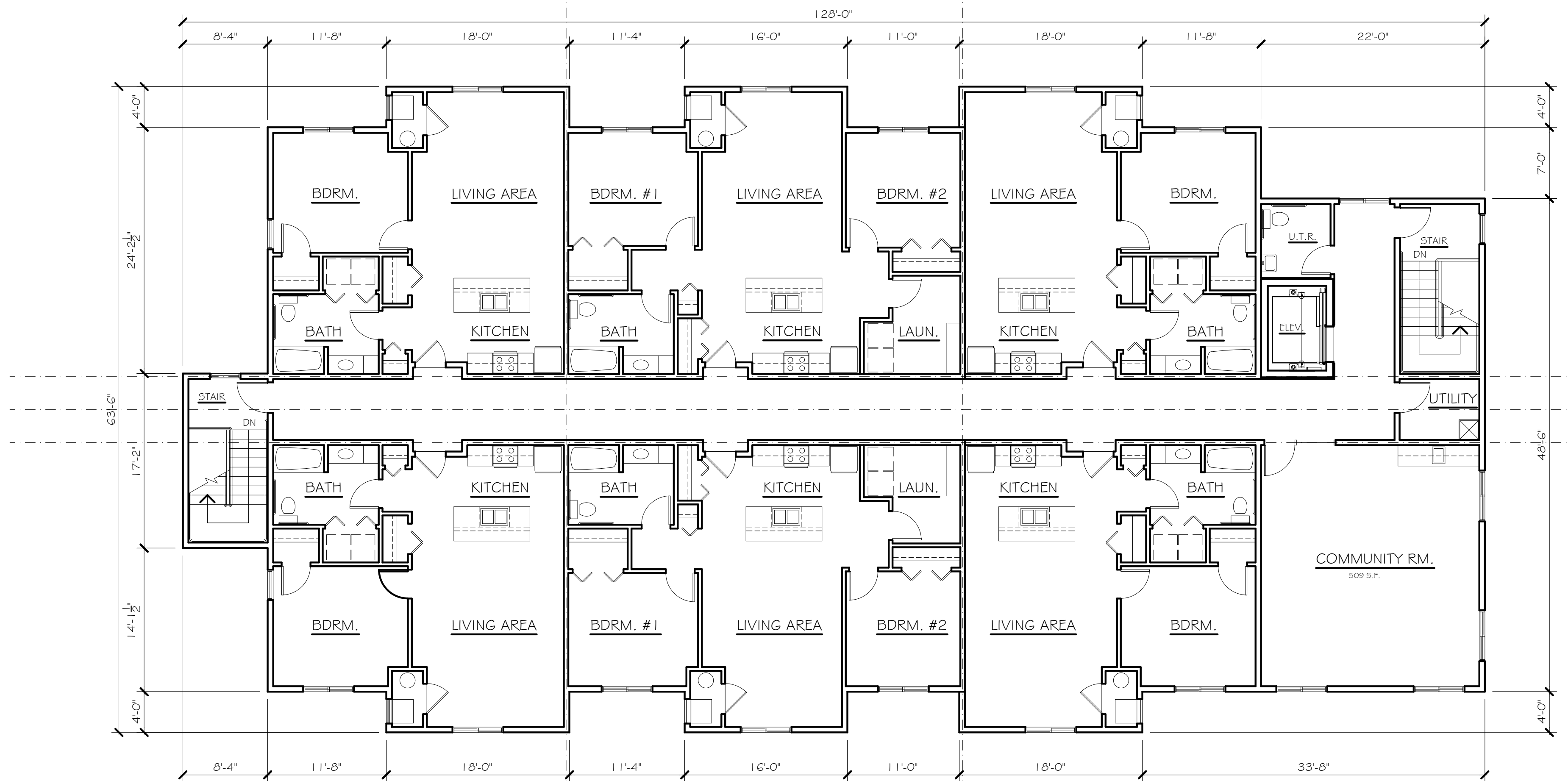

UPPER LEVEL PLAN
SCALE: 1/8" = 1'-0"



MAIN LEVEL PLAN
SCALE: 1/8" = 1'-0"

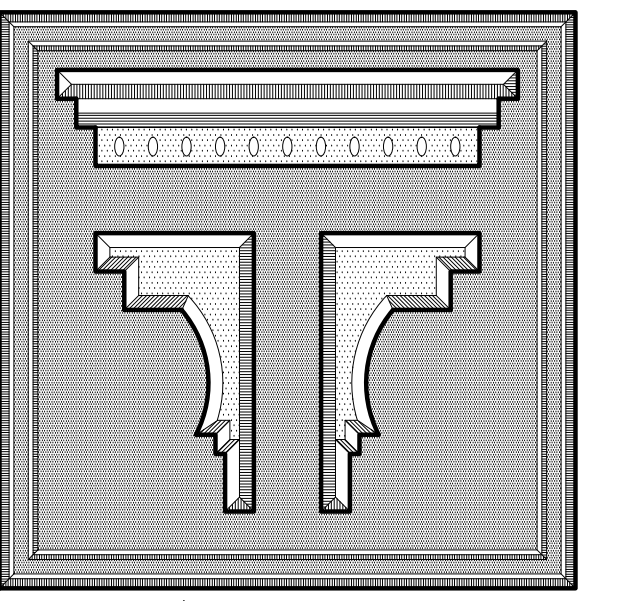

kendra c.
THOMPSON
architects, p.c.
803 Cherry Street
Manistee, MI 49660
tel: 231.723.4195
thompson.kendra@sbcglobal.net
www.kendraithompson-architects.com

NO.	REVISIONS / SUBMISSIONS	DATE
3	SITE PLAN REVIEW	11/2/2020
2	DESIGN DEVELOPMENT	10/29/2020
1	DESIGN DEVELOPMENT	10/24/2020

PROJECT NAME
NEW HOUSING PROJECT:
SHELBY TRAILS
220 WALNUT STREET
SHELBY, MICHIGAN

DRAWING TITLE
MAIN & UPPER LEVEL PLANS

SEAL	DRAWN KCT	KCT PROJECT NO. KT-219026
	REVIEWED KCT	DRAWING NO. A202
	DATE DEC 2019	SHEET NO.
	SCALE AS NOTED	4 OF 7

Copyright 2020 Kendra C. Thompson Architects, P.C.

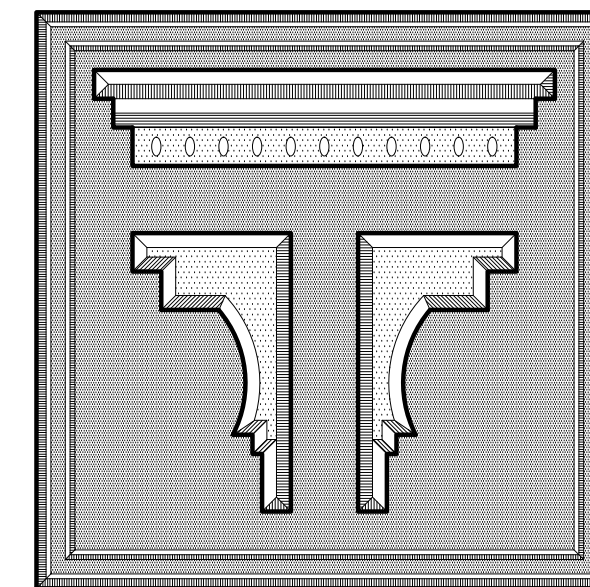

kendra c.
THOMPSON
 architects, p.c.
 803 Cherry Street
 Manistee, MI 49660
 tel: 231.723.4195
 thompson.kendra@sbcglobal.net
 www.kendraithompson-architects.com



ONE BEDROOM
 798 sf

TWO BEDROOM
 1029 sf

UNIT PLANS

SCALE: 1/4" = 1'-0"

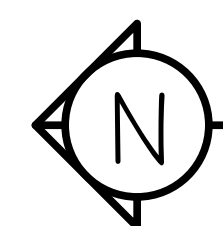

NO.	REVISIONS / SUBMISSIONS	DATE
3	SITE PLAN REVIEW	11/2/2020
2	DESIGN DEVELOPMENT	10/29/2020
1	DESIGN DEVELOPMENT	10/24/2020

PROJECT NAME
 NEW HOUSING PROJECT:
SHELBY TRAILS
 220 WALNUT STREET
 SHELBY, MICHIGAN

DRAWING TITLE
UNIT PLANS

SEAL	DRAWN KCT	KCT PROJECT NO. KT-219026
	REVIEWED KCT	DRAWING NO. A203
	DATE DEC 2019	SHEET NO.
	SCALE AS NOTED	5 OF 7

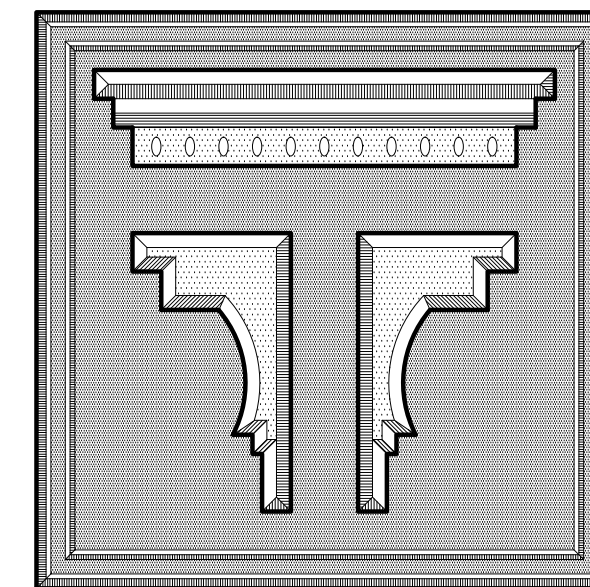

kendra c.
THOMPSON
 architects, p.c.
 803 Cherry Street
 Manistee, MI 49660
 tel: 231.723.4195
 thompson.kendra@sbcglobal.net
 www.kendraithompson-architects.com



**CONCEPTUAL
 WEST ELEVATION**

SCALE: 1/8" = 1'-0"



**CONCEPTUAL
 SOUTH ELEVATION**

SCALE: 1/8" = 1'-0"



**CONCEPTUAL
 EAST ELEVATION**

SCALE: 1/8" = 1'-0"



**CONCEPTUAL
 NORTH ELEVATION**

SCALE: 1/8" = 1'-0"

NO.	REVISIONS / SUBMISSIONS	DATE
3	SITE PLAN REVIEW	11/2/2020
2	DESIGN DEVELOPMENT	10/29/2020
1	DESIGN DEVELOPMENT	10/24/2020

PROJECT NAME
 NEW HOUSING PROJECT:
SHELBY TRAILS
 220 WALNUT STREET
 SHELBY, MICHIGAN

DRAWING TITLE
BUILDING ELEVATIONS

SEAL	DRAWN KCT	KCT PROJECT NO. KT-219026
	REVIEWED KCT	DRAWING NO. A300
	DATE DEC 2019	SHEET NO.
	SCALE AS NOTED	7 OF 7

Copyright 2020 Kendra C. Thompson Architects, P.C.