

ARC WELDING ROBOT

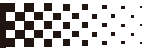

SPECIAL FOR WELDING
(Gas shielding, Argon arc, Laser, Aluminum, Stainless steel, Carbon steel)

Number of axis	6-axis		Maximum speed	Moving range
Motion radius	1500mm	J1 axis S	245°/s	$\pm 180^\circ$
Power capacity	4.5KVA	J2 axis L	210°/s	+90°~-170°
Max Payload	10KG	J3 axis U	250°/s	+160°~-92°
Protection class	IP65/IP67	J4 axis R	330°/s	$\pm 150^\circ$
Repeatability	$\pm 0.03\text{mm}$	J5 axis B	460°/s	+90°~-135°
Robot mass	145KG	J6 axis T	700°/s	$\pm 360^\circ$
Built-in air tube	$\phi 8$	J4 axis R(N.m)		22
Input/Output signals	Standard 16 in/16 out 24 VDC	J5 axis B(N.m)		22
Mounting position	Floor/ceiling	J6 axis T(N.m)		10



Installation Environment

Temperature	0-45°C	Humidity	20~80%RH(no condensing)	No corrosive or combustible gas, no water, no splashing	No excessive oil or dust
Vibrations	Below 4.9M/S2 (0.5G)	Altitude	Below 1000M	Away from electromagnetic source	Away from magnetic field

Control cabinet specifications

Overall dimension	650(width)*495(depth)*580(height)mm (with protrusions)
Approximate mass	80KG
Cooling method	Natural cooling
Power specifications	Three-phase AC220V 50/60HZ (built-in AC380V to AC220V isolation transformer)
Grounding	Industrial grounding (dedicated grounding, resistance below100Ω)
Input/Output signal	General signal:16 input,16 output
Position control method	Serial communication EtherCAT.TCP/IP
Memory capacity	JOB: 200000 steps,10000 robot commands (total 200M)
LAN(Host link)	Ethercat(1pc) TCP/IP(1pc)
Control mode	Servo position control
Ambient temperature	In use:0~ + 45°C,In storage: - 20~ + 60°C
Driver unit	AC servo system (6-axis); support external axis expansion
Relative humidity	10%~90%(no condensing)
Vibrate	Below 0.5G

Serial port I/F

RS485(1pc) RS422(1pc) RS232(1pc) CAN(1pc) USB(1pc)

Altitude

Below 1000m. Derate 1% for every additional 100m if over 1000m. Maximum 2000m.

Others

No dust, cutting fluid (including coolant), organic solvent, oil smoke, water, salt, medicine, anti-rust oil, strong microwave, ultraviolet light, X-ray, radiation exposure

Teach pendant specifications

External dimensions	280(width)*220(depth)*120(height)mm (with protrusions)
Gross weight	0.6KG
Material	Reinforced plastics
Display	8 inch color LED,640*480 pixels
Protection class	IP54
Cable Length	Standard:5m Optional:15m

Manipulator

Selector, axis operation, value, mode selection with key (teach mode/auto mode/remote mode), emergency stop, enable, USB port etc



Please read the user manual and relevant documentations before use.
 Contact official staff or distributor of MOKA if there are any errors, faults or if the robot is a harm to human safety.
 All data, drawings and specifications provided in this catalog are purely for information purposes and do not constitute a guarantee of these characteristics. The extent of goods delivered and services performed is determined by the subject matter of the specific contract. No liability accepted for errors or omissions.

Robot payload diagram

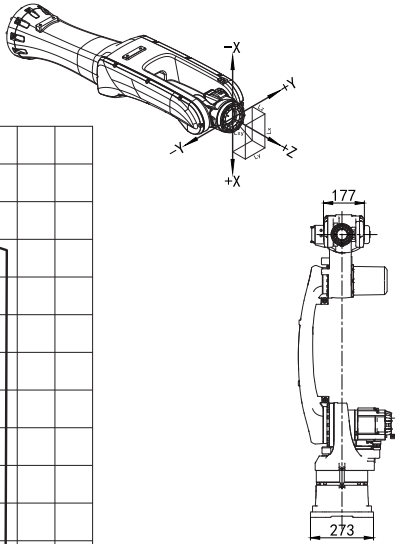
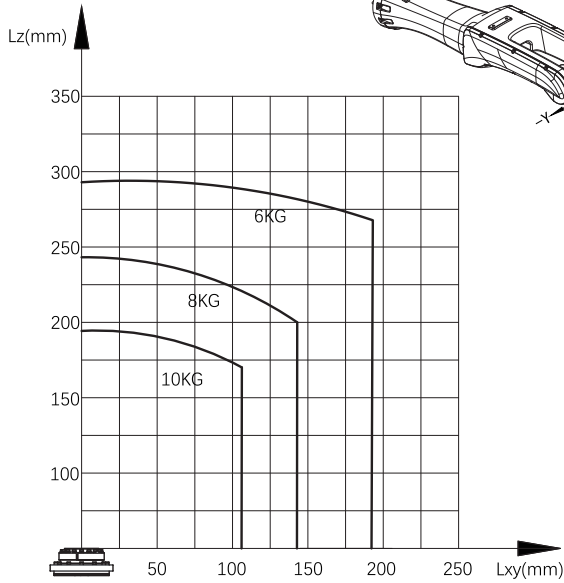

External dimensions and moving range

P moving range

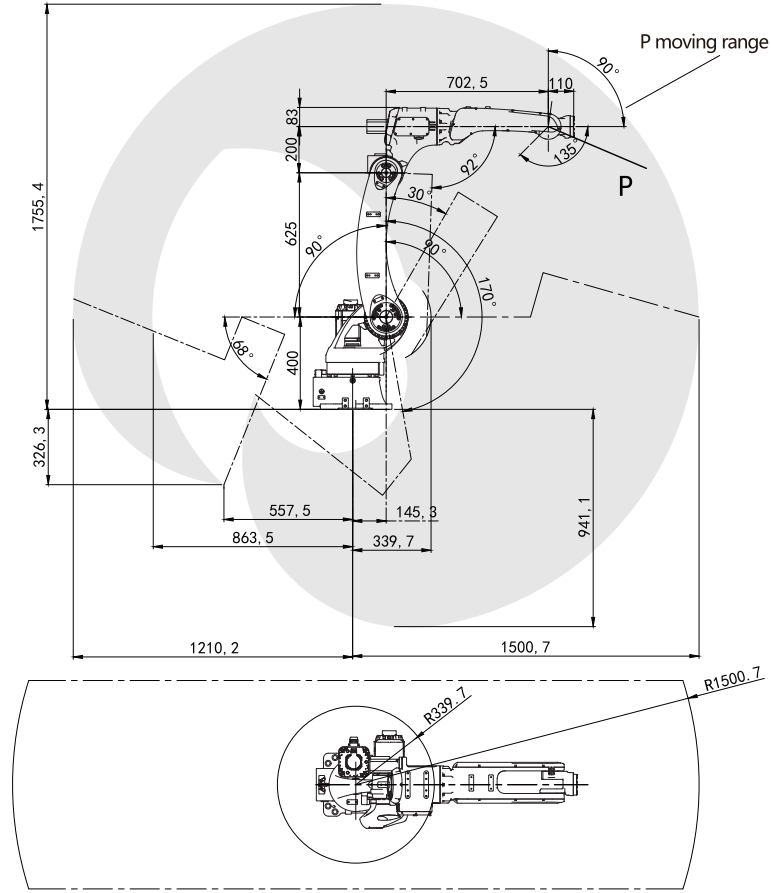

10KG
Max payload

$\pm 0.03\text{mm}$
Repeatability

1500mm
Moving range

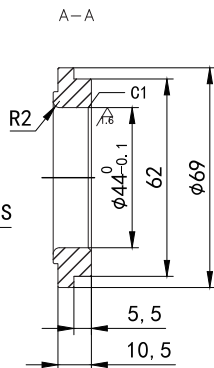
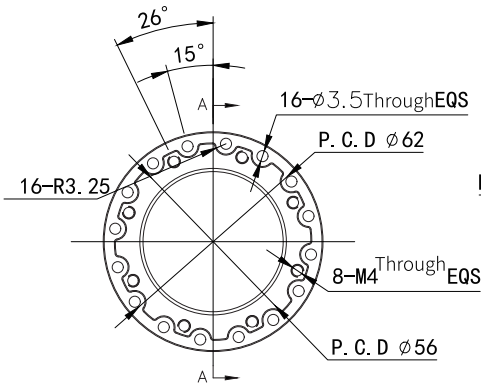

End flange installation dimensions

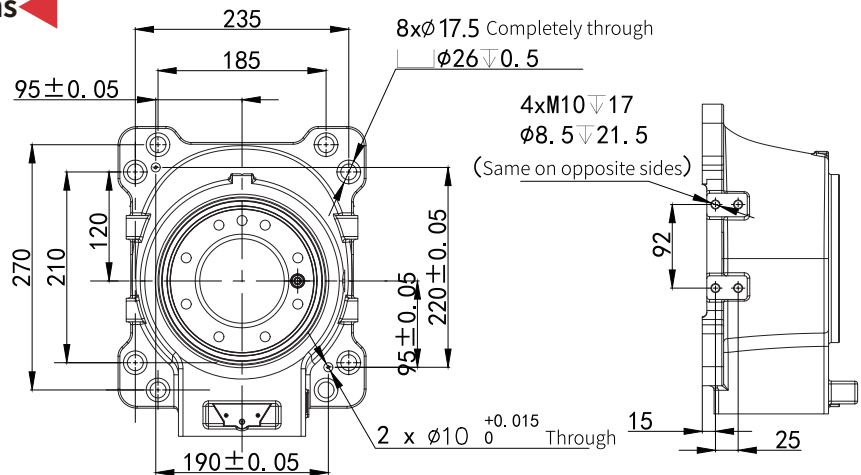
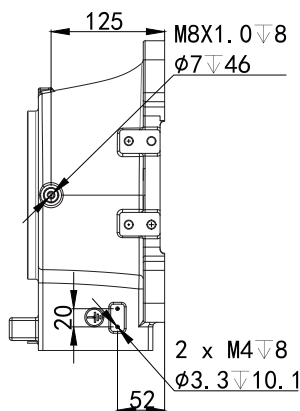

Base installation dimensions

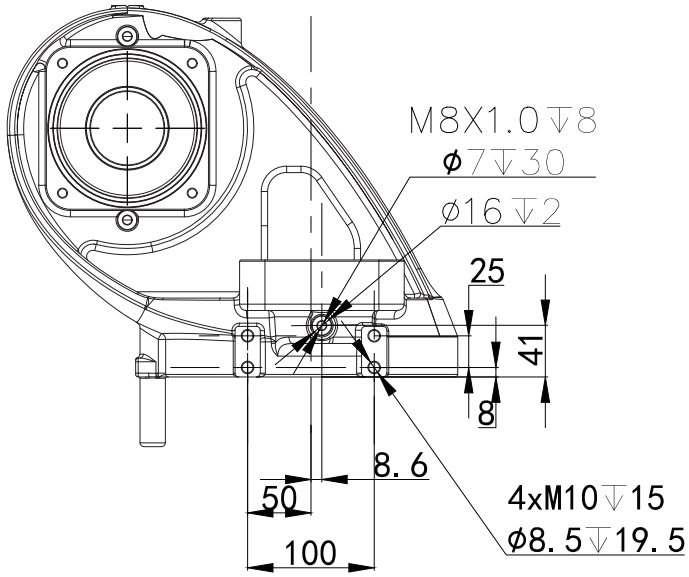
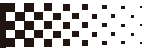

J2 transposition installation dimensions ◀

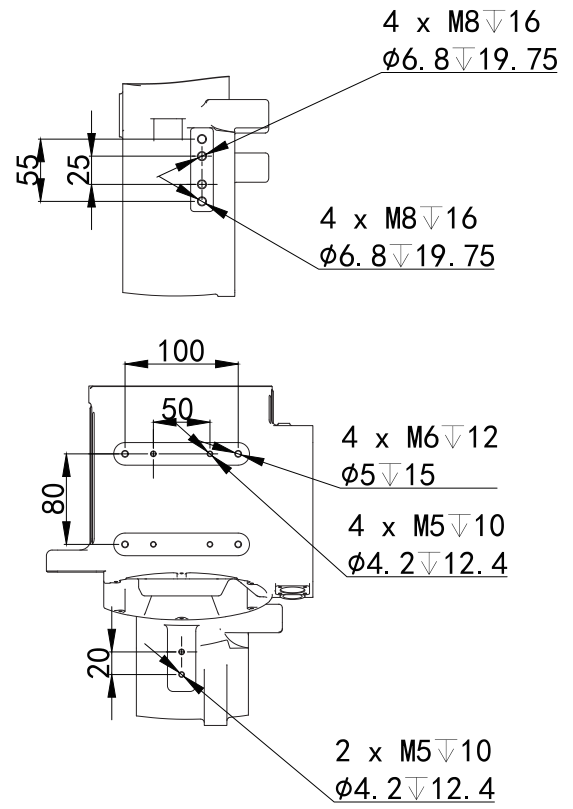

J4 motor seat installation dimensions ◀

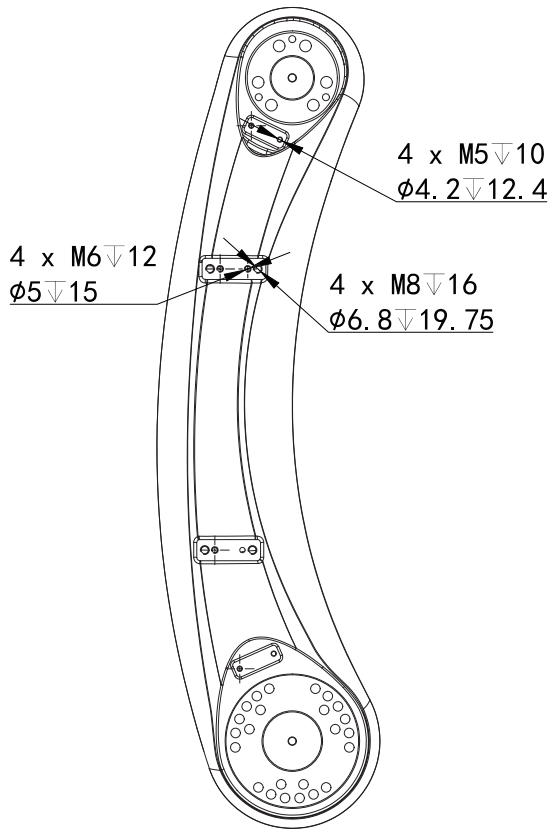

J3 arm installation dimensions ◀

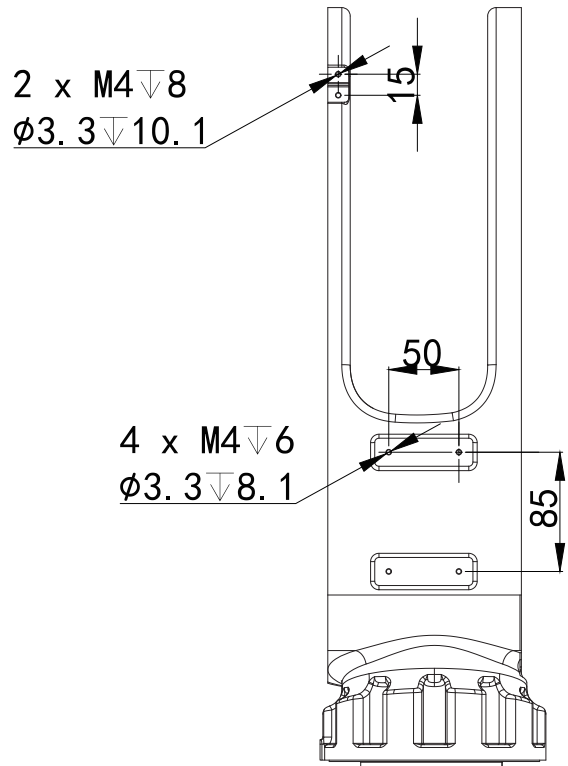

J5 wrist installation dimensions ◀

MB10W-2050

PAYLOAD : 10KG

REPEATABILITY : $\pm 0.03\text{mm}$

MOKA



SPECIAL FOR WELDING

(Gas shielding, Argon arc, Laser, Aluminum, Stainless steel, Carbon steel)

Number of axis	6-axis		Maximum speed	Moving range
Motion radius	2050mm	J1 axis S	204°/s	$\pm 180^\circ$
Power capacity	4.5KVA	J2 axis L	245°/s	+90°~-170°
Max Payload	10KG	J3 axis U	275°/s	+160°~-92°
Protection class	IP65/IP67	J4 axis R	330°/s	$\pm 150^\circ$
Repeatability	$\pm 0.03\text{mm}$	J5 axis B	460°/s	+90°~-135°
Robot mass	268KG	J6 axis T	700°/s	$\pm 360^\circ$
Built-in air tube	$\Phi 10$	J4 axis R(N.m)		25
Input/Output signals	Standard 16 in/16 out 24 VDC	J5 axis B(N.m)		25
Mounting position	Floor/ceiling	J6 axis T(N.m)		15

MADE BY MOKAROBOT

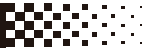

Installation Environment

Temperature	0-45°C	Humidity	20~80%RH(no condensing)	No corrosive or combustible gas, no water, no splashing	No excessive oil or dust
Vibrations	Below 4.9M/S2 (0.5G)	Altitude	Below 1000M	Away from electromagnetic source	Away from magnetic field

Control cabinet specifications

Overall dimension	650(width)*495(depth)*580(height)mm (with protrusions)
Approximate mass	80KG
Cooling method	Natural cooling
Power specifications	Three-phase AC220V 50/60HZ (built-in AC380V to AC220V isolation transformer)
Grounding	Industrial grounding (dedicated grounding, resistance below100Ω)
Input/Output signal	General signal:16 input,16 output
Position control method	Serial communication EtherCAT.TCP/IP
Memory capacity	JOB: 200000 steps,10000 robot commands (total 200M)
LAN(Host link)	Ethercat(1pc) TCP/IP(1pc)
Control mode	Servo position control
Ambient temperature	In use:0~ + 45°C,In storage: - 20~ + 60°C
Driver unit	AC servo system (6-axis); support external axis expansion
Relative humidity	10%~90%(no condensing)
Vibrate	Below 0.5G

Serial port I/F

RS485(1pc) RS422(1pc) RS232(1pc) CAN(1pc) USB(1pc)

Altitude

Below 1000m. Derate 1% for every additional 100m if over 1000m. Maximum 2000m.

Others

No dust, cutting fluid (including coolant), organic solvent, oil smoke, water, salt, medicine, anti-rust oil, strong microwave, ultraviolet light, X-ray, radiation exposure

Teach pendent specifications

External dimensions	280(width)*220(depth)*120(height)mm (with protrusions)
Gross weight	0.6KG
Material	Reinforced plastics
Display	8 inch color LED,640*480 pixels
Protection class	IP54
Cable Length	Standard:5m Optional:15m

Manipulator

Selector, axis operation, value, mode selection with key (teach mode/auto mode/remote mode), emergency stop, enable, USB port etc



Please read the user manual and relevant documentations before use.
 Contact official staff or distributor of MOKA if there are any errors, faults or if the robot is a harm to human safety.
 All data, drawings and specifications provided in this catalog are purely for information purposes and do not constitute a guarantee of these characteristics. The extent of goods delivered and services performed is determined by the subject matter of the specific contract. No liability accepted for errors or omissions.

Robot payload diagram

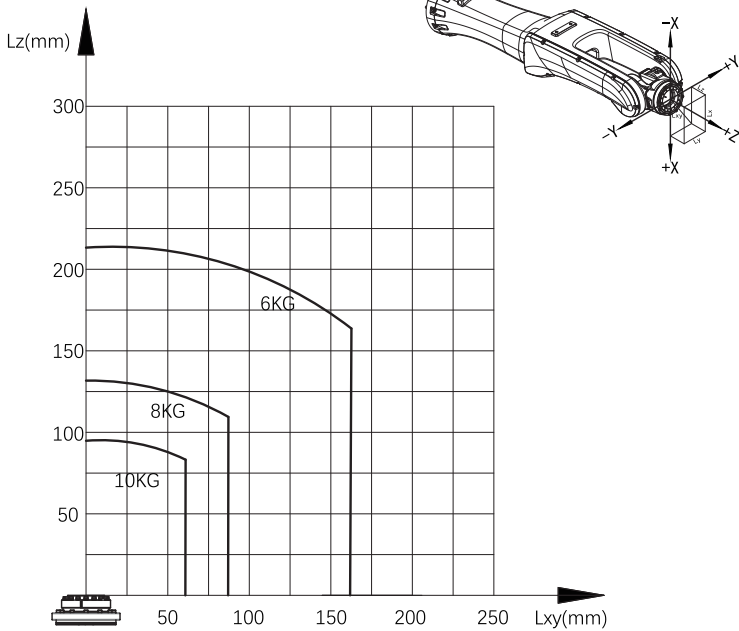

External dimensions and moving range

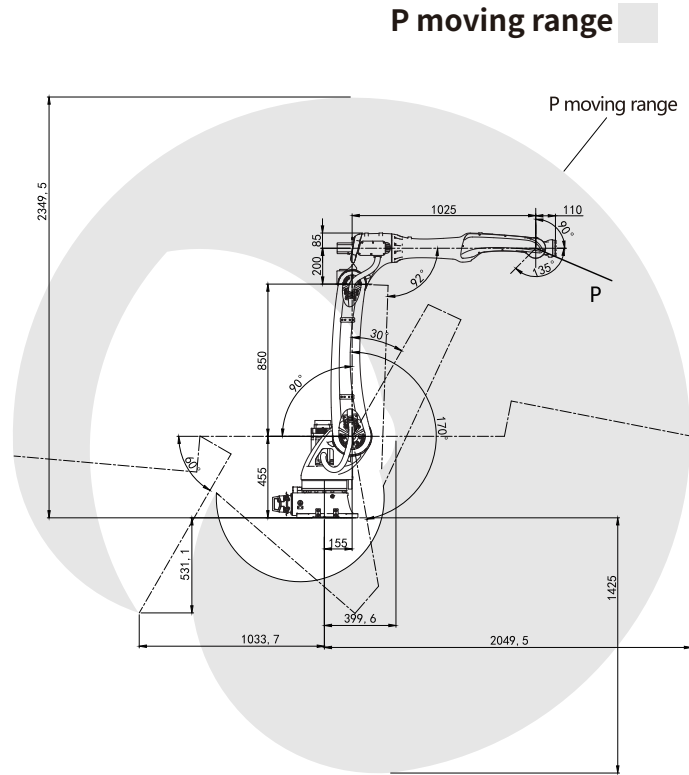

- Max payload**: 10KG
- Repeatability**: $\pm 0.03\text{mm}$
- Moving range**: 2050mm

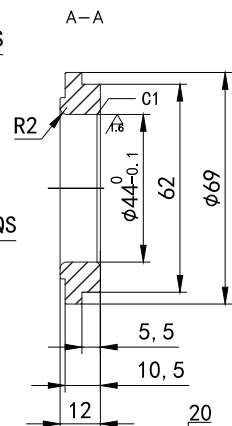
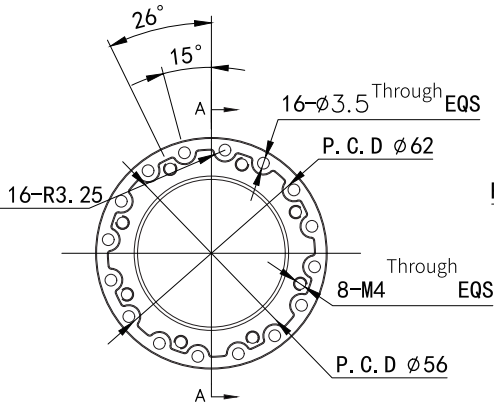

End flange installation dimensions

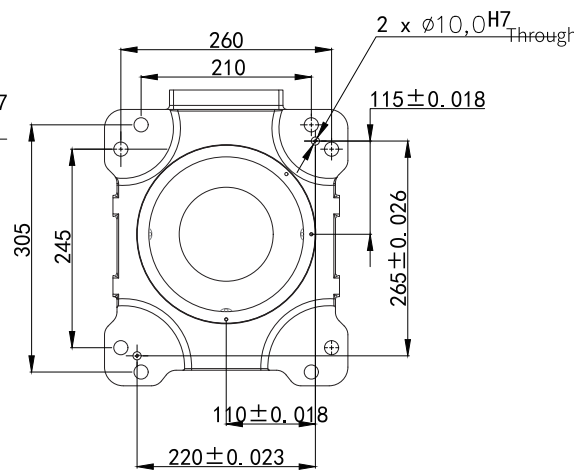
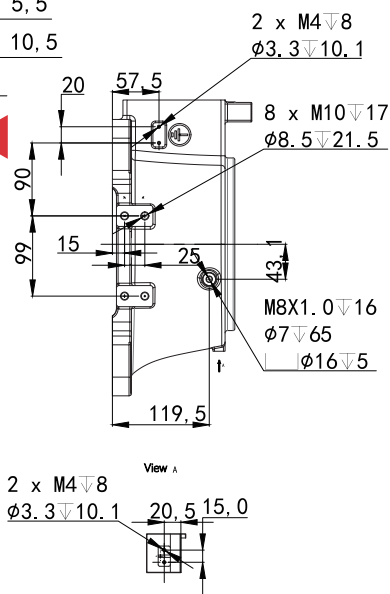

Base installation dimensions

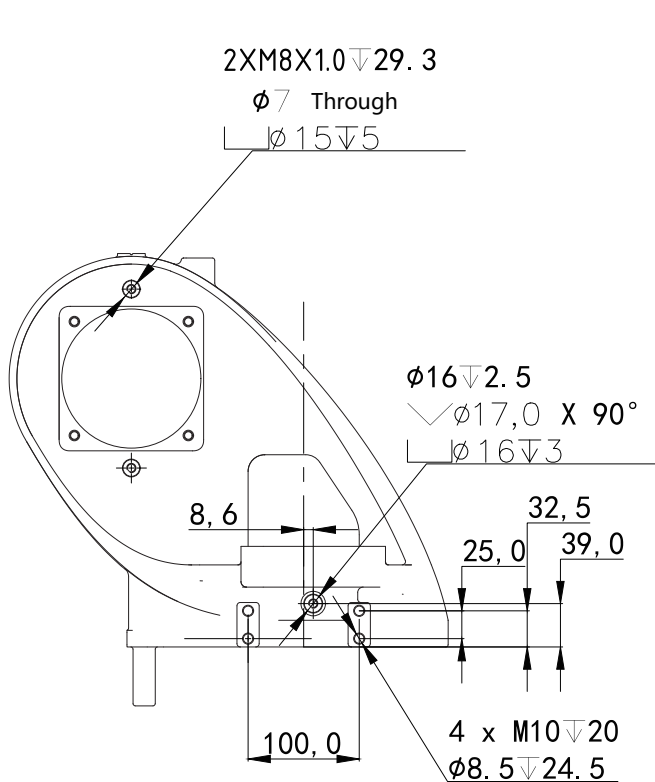

J2 transposition installation dimensions ◀

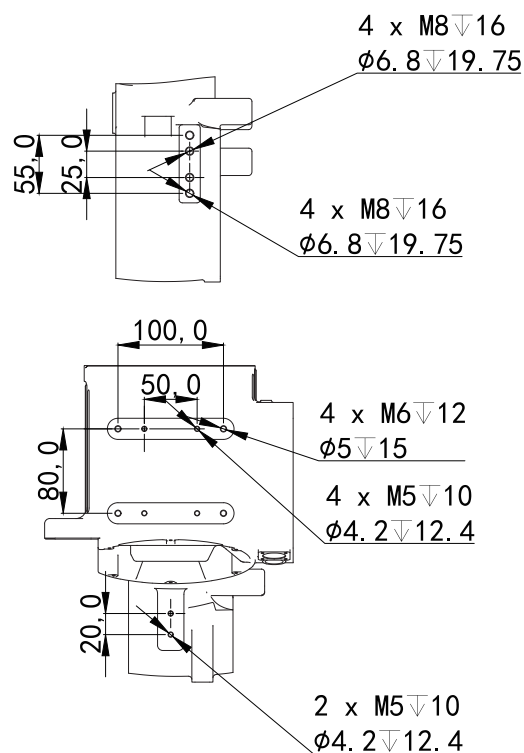

J4 motor seat installation dimensions ◀

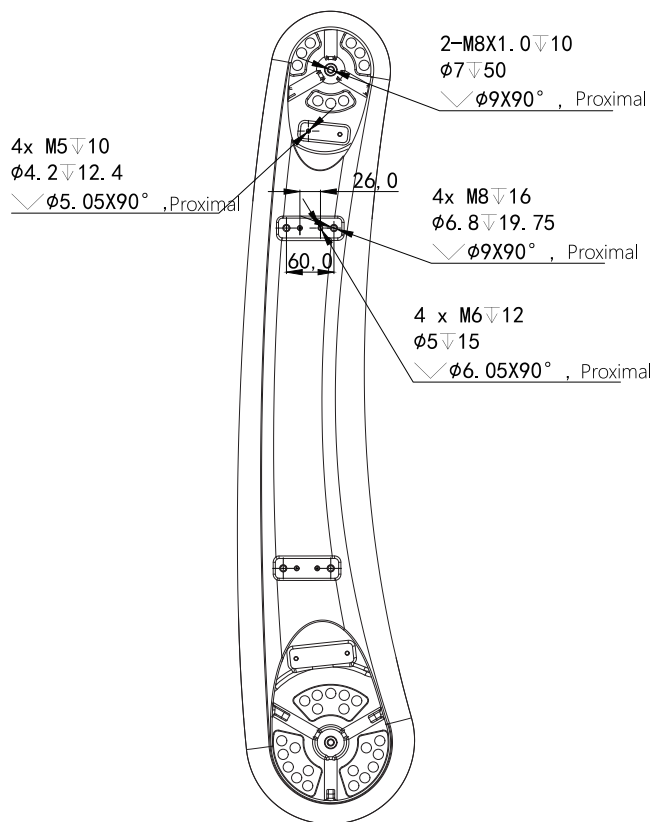

J3 arm installation dimensions ◀

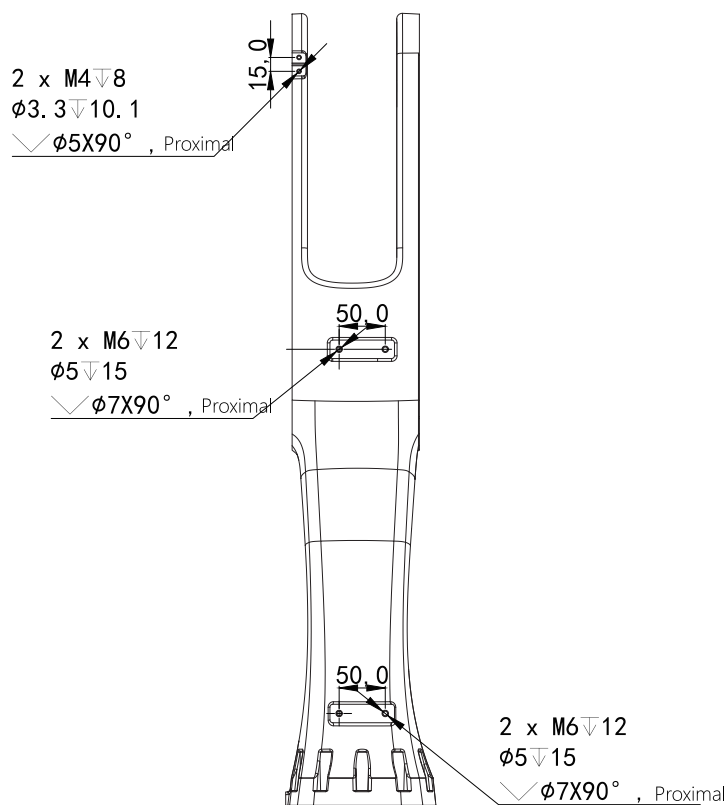

J5 wrist installation dimensions ◀

- ▶▶ Digital
- ▶▶ Low Spatter
- ▶▶ Ultra-Thin Sheet



Model	AMIG350LST
Rated Input Voltage/Frequency (V/Hz)	Three-phase 380±10%/50
Rated Input Capacity (KVA)	14
Rated Input Current (A)	21
Rated Output Voltage (V)	31.5
Rated Duty Cycle (%)	60
No-load Output Voltage (V)	96
Output Current/Voltage Range (A/V)	60/17~350/31.5
Welding Wire Diameter (mm)	0.8、1.0、1.2
Wire Feed Type	Push type
Gas Flow Rate (L/min)	15~20
Welding Torch Cooling Method	Air cooling
Enclosure Protection Class	IP23
Insulation Class	H
Dimensions (L×W×H, cm)	66×32×56
Weight (Kg)	55



ATTENTION

Please read the user manual and relevant documentations before use.

Contact official staff or distributor of MOKA if there are any errors, faults or if the robot is a harm to human safety.

All data, drawings and specifications provided in this catalog are purely for information purposes and do not constitute a guarantee of these characteristics. The extent of goods delivered and services performed is determined by the subject matter of the specific contract. No liability accepted for errors or omissions.

PERFORMANCE

Features three welding modes: low spatter, rapid spot welding, and constant voltage.

Enables ultra-low spatter welding for carbon steel ranging from 1mm to 3mm in thickness. Welding spatter is reduced by 60%.

Heat input is reduced by 10% to 20%, making thin-plate welding easier to control with minimal deformation.

Fully digital system achieves precise control of droplet transfer, ensuring consistent and stable welding quality.

Adopts soft-switching inverter technology to enhance overall machine reliability and energy efficiency.

Fully digital high-precision wire feed control system, featuring a dual-drive, dual-slave wire feed unit with encoder-based full digital control. Ensures stable wire feeding even when external factors such as power supply voltage or wire feed resistance fluctuate.

Application



▶ Electric Tricycle Welding



▶ Quick Spot Welding



0.8mm Plate Welding ◀

- ▶▶ Fast Pulse
- ▶▶ Carbon Steel & Stainless Steel



Model	NBC-500RP
Rated Input Voltage/Frequency (V/Hz)	Three-phase 380±15% 50/60
Rated Input Capacity (KVA)	24
Rated Input Current (A)	38
Rated Duty Cycle (%)	100
No-load Output Voltage (V)	76
Output Current/Voltage Range (A/V)	30/15.5~500/39
Welding Wire Diameter (mm)	0.8、1.0、1.2、1.4、1.6
Gas Flow Rate (L/min)	15~20
EMC Emission Class	A
Enclosure Protection Class	IP23
Insulation Class	H
Dimensions (L×W×H, cm)	66×32×56
Weight (Kg)	55



ATTENTION

Please read the user manual and relevant documentations before use.
 Contact official staff or distributor of MOKA if there are any errors, faults or if the robot is a harm to human safety.
 All data, drawings and specifications provided in this catalog are purely for information purposes and do not constitute a guarantee of these characteristics. The extent of goods delivered and services performed is determined by the subject matter of the specific contract. No liability accepted for errors or omissions.

WELDING PERFORMANCE

Features four welding modes: single pulse, rapid pulse, constant voltage, and deep penetration. Suitable for welding carbon steel and stainless steel.

Fully digital grating feedback motor control ensures more precise and stable wire feeding.

Can store up to 100 sets of welding parameters, which can be recalled by the robot at any time.

Equipped with contact sensing function to facilitate robot positioning, with high-voltage positioning as standard.

Real-time transmission of welding parameters to the robot, enabling arc tracking functionality.

User-friendly operation interface with one-knob adjustment for easy mastery.

One-pulse-one-droplet transfer technology for spatter-free welding.

Application



▶ Shipbuilding



▶ Wind Turbine Welding

▶ Pipe Intersection Welding

▶ Stainless Steel Welding

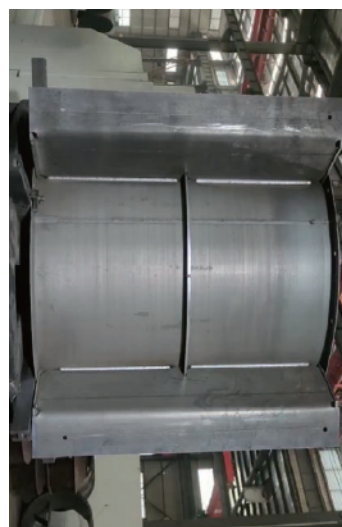
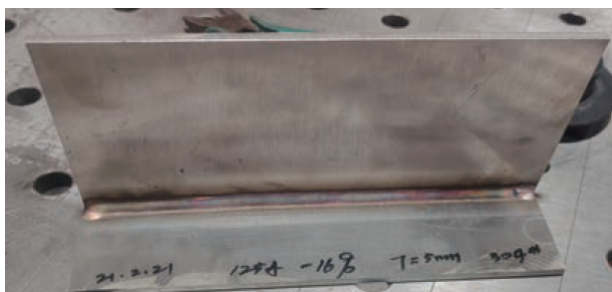

- ▶▶ Super double Pulse
- ▶▶ Scaly Weld Bead



Model	MIG-500RP
Rated Input Voltage/Frequency (V/Hz)	Three-phase 380±15% 50/60
Rated Input Capacity (KVA)	24
Rated Input Current (A)	38
Rated Output Voltage (V)	39
Rated Duty Cycle (%)	100
No-load Output Voltage (V)	76
Output Current/Voltage Range (A/V)	30/15.5~500/39
Welding Wire Diameter (mm)	0.8、1.0、1.2、1.4、1.6
Wire Feed Type	Push type
Gas Flow Rate (L/min)	15~20
Welding Torch Cooling Method	Air cooling
Enclosure Protection Class	IP23
Insulation Class	H
Dimensions (L×W×H, cm)	66×32×56
Weight (Kg)	55



ATTENTION

Please read the user manual and relevant documentations before use.
 Contact official staff or distributor of MOKA if there are any errors, faults or if the robot is a harm to human safety.
 All data, drawings and specifications provided in this catalog are purely for information purposes and do not constitute a guarantee of these characteristics. The extent of goods delivered and services performed is determined by the subject matter of the specific contract. No liability accepted for errors or omissions.

WELDING PERFORMANCE

Features four welding modes: constant voltage, single pulse, double pulse, and super double pulse.

It can weld carbon steel, stainless steel, aluminum and its alloys, copper and its alloys, and other non-ferrous metals.

It is equipped with a super double pulse welding function for carbon steel, stainless steel, and aluminum alloys.

It can achieve spatter-free super double pulse welding on aluminum alloy workpieces with a thickness of 1.2–4 mm. The scaly weld bead formation is comparable to that of TIG welding, and the welding efficiency is higher than TIG welding.

Mainly used in bicycles, scooters, leisure furniture, new energy vehicles, and other fields.

Application



▶ **Motorcycle Frame**



▶ **Scooter**



▶ **Leisure Furniture**



▶ **Shared Bicycle**



▶ **Other Applications**

350A Air-Cooled Welding Torch TRM352P



Rating 350A CO₂
270A mixed gases M21 (ISO 14175)
Duty cycle 100%

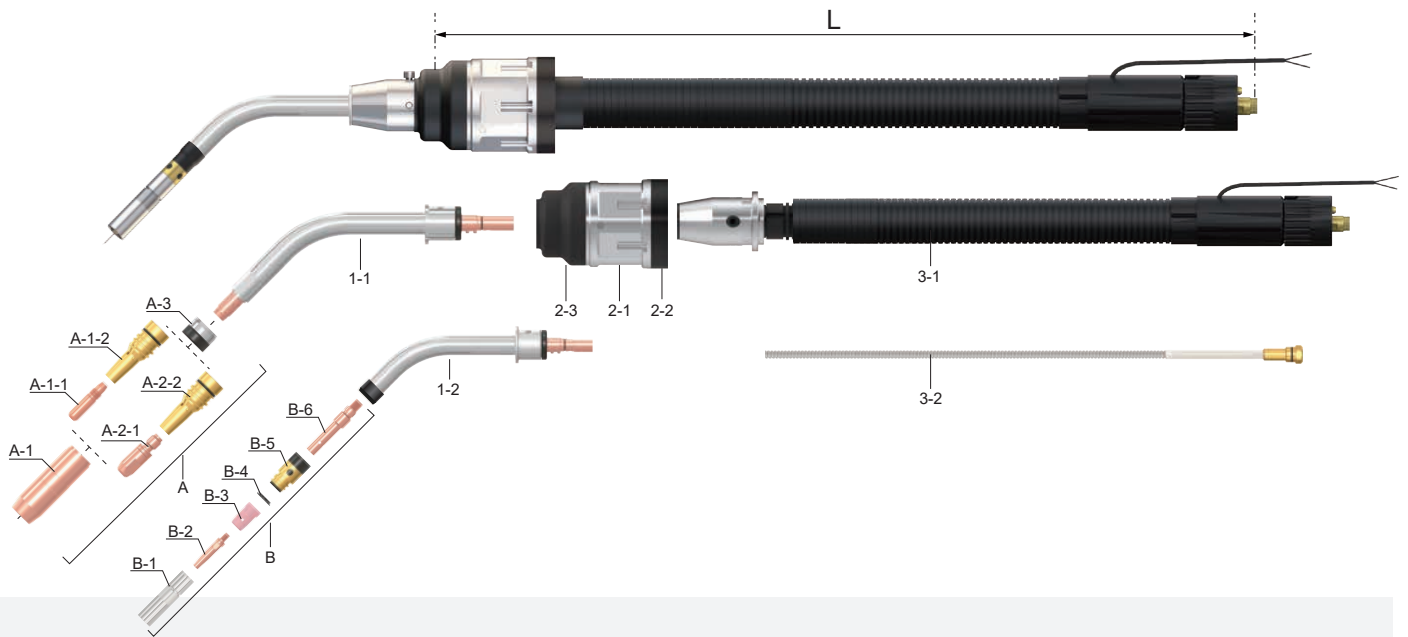

TCP DATA

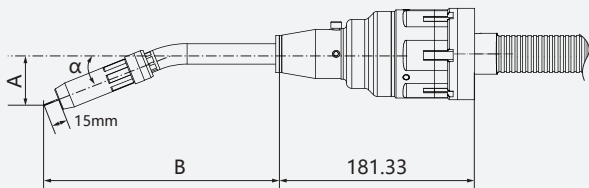

α	A(mm)	B(mm)	Angle	Neck Part No.
31°	103.3	224.66	31°	TRM501-P31-B
31°	103.3	393.16	31°	TRM501-P31L
45°	129.5	221.86	45°	TRM501-P45L
45°	129.5	276.86	45°	TRM501-P45L1

COLLISION SENSOR DATA SHEET

ITEM	TRM316-01-N6	TRM316-01-N10
Size	Diameter Φ 85/Height 89mm	Diameter Φ 85/Height 89mm
Weight	600g	600g
Sensing accuracy	Deflection in X/Y direction 0.9°~1.5°	Deflection in X/Y direction 0.9°~1.5°
Maximum deflection	X/Y deflection approx. 10°	X/Y deflection approx. 10°
Repeatability(400mm)	Within 0.15mm	Within 0.15mm
Trigger force	About 30-45N in X/Y (400mm) direction	About 60-70N in X/Y (400mm) direction
IP protection level	IP21	IP21
Switching capacity	10A/250VAC	10A/250VAC
Ambient temperature	-10°C to +55°C	-10°C to +55°C
Relative humidity	70% at 20 °C during operation	70% at 20 °C during operation

ORDER GUIDE

Item	Order NO.	Product Description
ROBOT TORCH	TRM352(P)	Through-arm air cooled robot welding torch

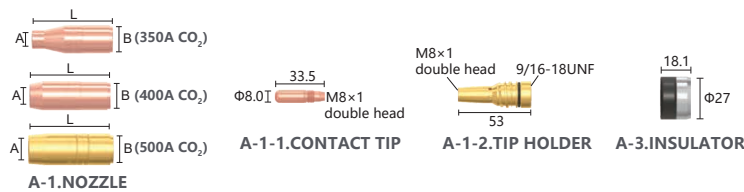

1. TORCH NECK ASSEMBLY

Item	Order NO.	Product Description
1-1. GOOSE NECK	TRM501-22	Goose neck(22°,one button quick change)
	TRM501-22L	Goose neck(22°, extended, one button quick change)
	TRM501-45	Goose neck(45°,one button quick change)
	TRM501-45L	Goose neck(45°, extended, one button quick change)
	TRM501-45L1	Goose neck(45°, extended, one button quick change)
	TRM501-45L2	Goose neck(45°, extended, one button quick change)
	TRM501-60	Goose neck(60°,one button quick change)

GOOSE NECK CONSUMABLES

Item	Order NO.	Product Description
A-1.NOZZLE	TRM012-14-50	L=70.0, A =Φ13, B=Φ24, contact tip flush
	TRM012-16-50	L=73.2, A =Φ13, B=Φ24, contact tip recess 3.2mm
	TRM012-18-50	L=66.8, A=Φ13, B=Φ24, contact tip stick out 3.2mm
	TRM012-14-62	L=70.0, A =Φ16, B=Φ24, contact tip flush
	TRM012-16-62	L=73.2, A =Φ16, B=Φ24, contact tip recess 3.2mm
	TRM012-18-62	L=66.8, A=Φ16, B=Φ24, contact tip stick out 3.2mm
A-1-1.CONTACT TIP	TRM035-02-08	CuCrZr, Φ0.8 wire (steel)
	TRM035-02-10	CuCrZr, Φ1.0 wire (steel)
	TRM035-02-12	CuCrZr, Φ1.2 wire (steel)
	TRM035-02-14	CuCrZr, Φ1.4 wire (steel)
	TRM035-02-16	CuCrZr, Φ1.6 wire (steel)
A-1-2.TIP HOLDER	TRM042-04	Brass
A-3.INSULATOR	TRM501-05R	American type R series

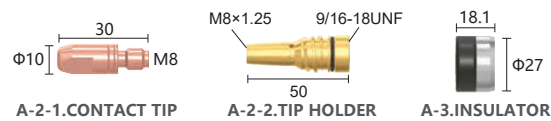

GOOSE NECK CONSUMABLES(EURO SERIES)

Item	Order NO.	Product Description
A-2-1.CONTACT TIP	TRM035-02-08	CuCrZr, Φ0.8 wire (steel)
	TRM035-02-10	CuCrZr, Φ1.0 wire (steel)
	TRM035-02-12	CuCrZr, Φ1.2 wire (steel)
	TRM035-02-14	CuCrZr, Φ1.4 wire (steel)
	TRM035-02-16	CuCrZr, Φ1.6 wire (steel)
A-2-2.TIP HOLDER	TRM042-04	Brass
A-3.INSULATOR	TRM501-05R	

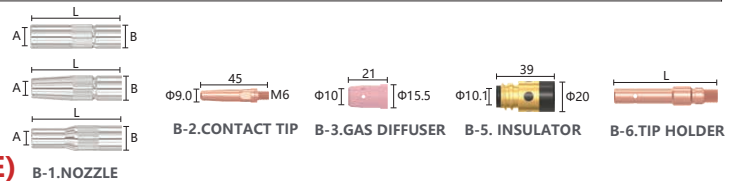

GOOSE NECK CONSUMABLES(JAPANESE STYE)

Item	Order NO.	Product Description
1-2. GOOSE NECK	TRM501-P31-B	Goose neck(Japanese type, 31° , one button quick change)
	TRM501-P31L	Goose neck(Japanese type, 31° long, one button quick change)
	TRM501-P45L	Goose neck(Japanese type, 45° middle, one button quick change)
	TRM501-P45L1	Goose neck(Japanese type, 45° long, one button quick change)
B-1.NOZZLE	TMP012-3-16	L=73.0mm,A=Φ16mm,B=Φ20mm
	TMP012-3-13	L=73.0mm,A=Φ13mm,B=Φ20mm
	TMP012-3-12	L=73.0mm,A=Φ12mm,B=Φ20mm
	TMP012-3B-10	L=73.0mm,A=Φ10mm,B=Φ20mm
	TMP012-3B-12	L=73.0mm, A=Φ12mm,B=Φ20mm
	B-2.CONTACT TIP	TMP030-2-R08
TMP030-2-R10		CuCrZr, φ1.0 wire (steel)
TMP030-2-R12		CuCrZr, φ1.2 wire (steel)
B-3.GAS DIFFUSER	TMP040-3	Pink
B-4.SPRING WASHER	TMP041-3-2	
B-5.INSULATOR	TMPTFZ35101-LX	
B-6.TIP HOLDER	TMP053-1C	L=68.5, contact tip recess 3.0mm
	TMP053-2C	L=75.0, contact tip stick out 3.5mm
	TMP053-3C	L=71.5, contact tip flush

2.ANTI-COLLISION UNIT

Item	Order NO.	Product Description
2-1. COLLISION SENSOR	TRM316-01-N6	Through-arm hollow collision sensor (standard goose neck)
	TRM316-01-N10	Through-arm hollow collision sensor (L/L1/L2 goose neck)
2-2. Flange	See P50-51 flange selection table	Including the installed screws.
2-3. DUST COVER	TRM508-061-1-4-A	Black

3.CABLE ASSEMBLY

Item	Order NO.	Product Description
3-1. CABLE ASSEMBLY	TRM352-DL	Cable assembly
	TRM150-08-23	One-piece, overall length 2.3m, (steel) wire 0.8-0.9mm
3-2. LINER	TRM150-12-23	One-piece, overall length 2.3m, (steel) wire 1.0-1.2mm
	TRM150-16-23	One-piece, overall length 2.3m, (steel) wire 1.4-1.6mm

* If the cable length exceeds 2 metres, please contact sales in advance when ordering the length of the wire feeder tube.

550A Liquid-Cooled Welding Torch TRM602WHD



Rating 550A CO₂
500A mixed gases M21 (ISO 14175)
Duty cycle 100%

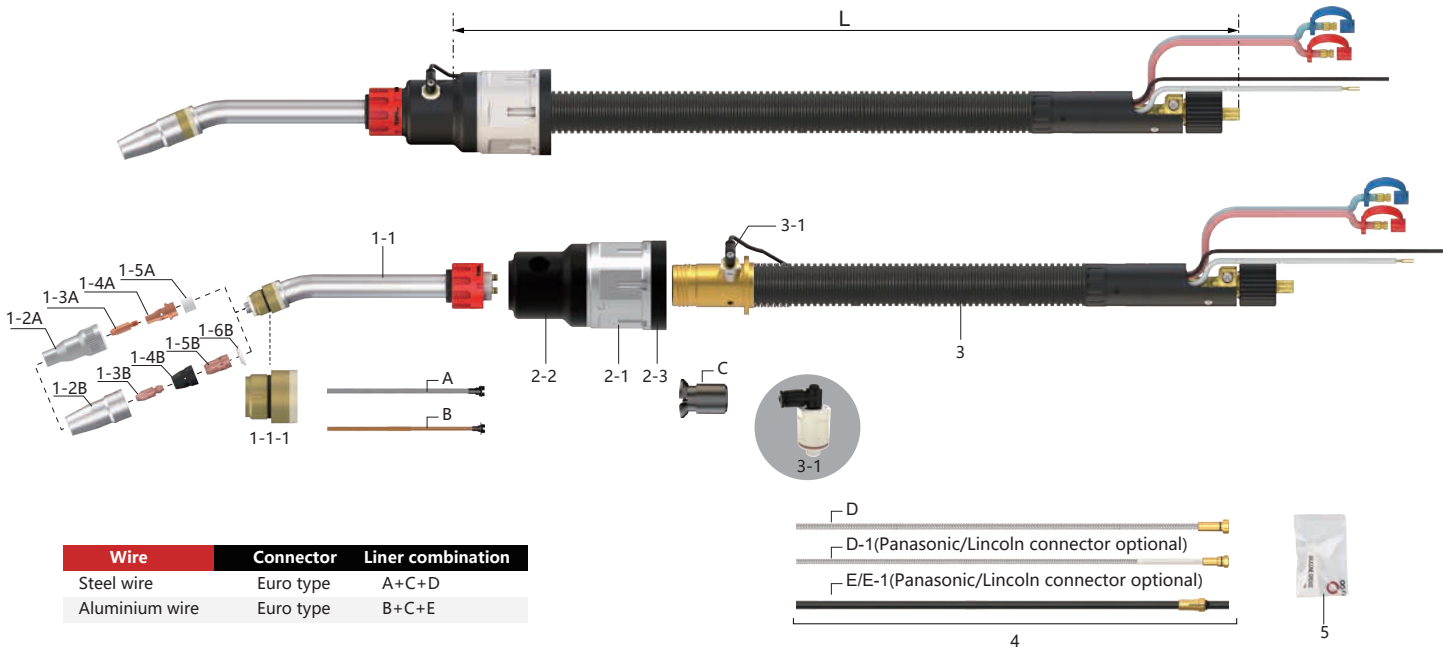

TCP DATA

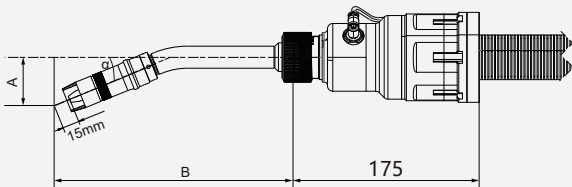

α	A(mm)	B(mm)	Angle	Neck Part No.
22°	44.3	291.6	22°	550WTE51-22L240H023
22°	44.3	392.6	22°	550WTE51-22L341H023
22°	44.3	452.6	22°	550WTE51-22L401H023
22°	44.3	549.99	22°	550WTE51-22L499H023
36°	76.6	289.57	36°	550WTE51-36L245H044
36°	76.6	377.25	36°	550WTE51-36L333H044
36°	76.6	531.47	36°	550WTE51-36L487H044
45°	111.27	272.96	45°	550WTE51-45L234H073
45°	111.27	372.96	45°	550WTE51-45L334H073
45°	111.27	454.56	45°	550WTE51-45L416H073
45°	111.27	514.6	45°	550WTE51-45L476H073
180°	0	298.45	180°	550WTE51-180L243H0
180°	0	399.45	180°	550WTE51-180L344H0
22°	44.3	218.06	22°	550WTE51-22L167H023

COLLISION SENSOR DATA SHEET

ITEM	TRM316-01-N6	TRM316-01-N10	TRM316-01-N16
Size	Diameter Φ 85/Height 89mm	Diameter Φ 85/Height 89mm	Diameter Φ 85/Height 89mm
Weight	600g	600g	600g
Sensing accuracy	Deflection in X/Y direction 0.9°~1.5 °	Deflection in X/Y direction 0.9°~1.5 °	Deflection in X/Y direction 0.9°~1.5 °
Maximum deflection	X/Y deflection approx. 10 °	X/Y deflection approx. 10 °	X/Y deflection approx. 6 °
Repeatability(400mm)	Within 0.15mm	Within 0.15mm	Within 0.15mm
Trigger force	About 30~45N in X/Y (400mm) direction	About 60~70N in X/Y (400mm) direction	About 90~100N in X/Y (400mm) direction
IP protection level	IP21	IP21	IP21
Switching capacity	10A/250VAC	10A/250VAC	10A/250VAC
Ambient temperature	-10°C to +55°C	-10°C to +55°C	-10°C to +55°C
Relative humidity	70% at 20 °C during operation	70% at 20 °C during operation	70% at 20 °C during operation

↳ **Suitable Industries:**

- > Construction Machinery Industry
- > Steel Structure Industry

ORDER GUIDE

Item	Order NO.	Product Description
ROBOT TORCH	TRM602WHD	Through-arm liquid cooled robot welding torch(Optional wire brake function)

1.TORCH NECK ASSEMBLY

Item	Order NO.	Product Description
1-1. GOOSE NECK	550WTE51-22L240H023	22°, standard, straight length 150mm
	550WTE51-22L341H023	22°, extended 101mm, straight length 251mm
	550WTE51-22L401H023	22°, extended 161mm, straight length 311mm
	550WTE51-22L499H023	22°, extended 259mm, straight length 409mm
	550WTE51-36L245H044	36°, standard, straight length 145mm
	550WTE51-36L333H044	36°, extended 88mm, straight length 233mm
	550WTE51-36L487H044	36°, extended 242mm, straight length 387mm
	550WTE51-45L234H073	45°, standard, straight length 117mm
	550WTE51-45L334H073	45°, extended 100mm, straight length 217mm
	550WTE51-45L416H073	45°, extended 182mm, straight length 299mm
	550WTE51-45L476H073	45°, extended 242mm, straight length 359mm
	550WTE51-180L243H0	Straight neck, total length 272mm
	550WTE51-180L344H0	Straight neck, total length 373mm
	550WTE51-22L167H023	22°, short neck, straight length 78mm
	1-1-1. NOZZLE HOLDER	550WTE51-03-ZJ
A. NECK LINER	TRM154-08-60	(Steel) wire Φ 0.8-0.9mm
	TRM154-12-60	(Steel) wire Φ 1.0-1.2mm
	TRM154-16-60	(Steel) wire Φ 1.4-1.6mm
C. WIRE GUIDE BUSHING	TRM602W-061JS-11	Wire guide bushing(Φ 0.8mm- Φ 1.6mm)

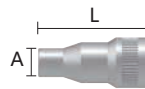

1-2A.NOZZLE

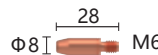

1-3A.CONTACT TIP

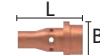

1-4A.TIP HOLDER



1-5A.INSULATOR

GOOSE NECK CONSUMABLES (M6)

Item	Order NO.	Product Description
1-2A. NOZZLE	TRM015-62-14C	Tip flush (nickel plating) ; L=63.5mm, A=14mm
	TRM015-61-13C	Tip recess (nickel plating) ; L=65.5mm, A=13mm
1-3A. CONTACT TIP	TRM035-12-08	CuCrZr, Φ 0.8 wire (steel)
	TRM035-12-10	CuCrZr, Φ 1.0 wire (steel)
	TRM035-12-12	CuCrZr, Φ 1.2 wire (steel)
	TRM035-12-14	CuCrZr, Φ 1.4 wire (steel)
	TRM035-12-16	CuCrZr, Φ 1.6 wire (steel)
	1-4A. TIP HOLDER	TRM046-05
1-5A. INSULATOR	550WTE51-16	Insulator (White)

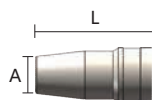

1-2B.NOZZLE



1-3B.CONTACT TIP



1-4B.CONTACT TIP

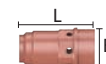

1-5B.TIP HOLDER



1-6B.INSULATOR

GOOSE NECK CONSUMABLES (M8)

Item	Order NO.	Product Description
1-2B. NOZZLE	TRM015-62-16C	Tip flush (nickel plating) ; L=63.5mm, A=16mm
	TRM015-63-16C	Tip stick out (nickel plating) ; L=60.5mm, A=16mm
	TRM015-62-14C	Tip flush (nickel plating) ; L=63.5mm, A=14mm
	TRM015-61-17C	Tip recess (nickel plating) ; L=65.5mm, A=17mm

550A Liquid-Cooled Welding Torch TRM602WHD



Rating 550A CO₂
500A mixed gases M21 (ISO 14175)
Duty cycle 100%



GOOSE NECK CONSUMABLES (M8)

Item	Order NO.	Product Description
1-3B. CONTACT TIP	TRM035-03-10	Φ1.0 (ultra long life, steel)
	TRM035-03-12	Φ1.2 (ultra long life, steel)
	TRM035-03-14	Φ1.4 (ultra long life, steel)
	TRM035-03-16	Φ1.6 (ultra long life, steel)
	TRM035-02-08	CuCrZr, Φ0.8 wire (steel)
	TRM035-02-10	CuCrZr, Φ1.0 wire (steel)
	TRM035-02-12	CuCrZr, Φ1.2 wire (steel)
	TRM035-02-14	CuCrZr, Φ1.4 wire (steel)
	TRM035-02-16	CuCrZr, Φ1.6 wire (steel)
1-4B. GAS DIFFUSER	3.1.4.0845	Black
1-5B. TIP HOLDER	TRM046-04	M8 L=27mm, B=M12X1
1-6B. INSULATOR	550WTE51-15	Insulator (White)

2.ANTI-COLLISION UNIT

Item	Order NO.	Product Description
2-1. COLLISION SENSOR	TRM316-01-N6	Suitable for 22L167
	TRM316-01-N10	Suitable for 22L240,22L341,36L245,36L333,45L234,45L334,180L243,180L344
	TRM316-01-N16	Suitable for 22L401,22L409,36L487,45L416,45L476
2-2. DUST COVER	TRM602W-061JS-15	Select when with wire brake function
	TRM602W-061JS-14	Select when without wire brake function
2-3. FLANGE	See P50-51 flange selection table	Including installed screws

3.CABLE ASSEMBLY

Item	Order NO.	Product Description
3. CABLE ASSEMBLY	TRM602W-DL	Liquid cooled cable assembly(Optional wire brake function)
3-1. WIRE BRAKE CYLINDER (Optional)	TRM602W-061JS-QG	Wire brake cylinder (component)

4.LINER OPTIONAL COMBINATION

Item	Order NO.	Product Description
D. LINER(Euro type)	TRM152B-08-23	(Steel) wire Φ0.8-0.9mm
	TRM152B-12-23	(Steel) wire Φ1.0-1.2mm
	TRM152B-16-23	(Steel) wire Φ1.4-1.6mm
D-1. LINER (Panasonic/Lincoln connector optional)	TRM150-08-23	(steel) wire Φ0.8-0.9mm
	TRM150-12-23	(steel) wire Φ1.0-1.2mm
	TRM150-16-23	(steel) wire Φ1.4-1.6mm

* If the cable length exceeds 2 metres, please contact sales in advance when ordering the length of the wire feeder tube.

5.ACCESSORY BAG

Item	Order NO.	Product Description
5. ACCESSORY BAG	TRM-AP-WT	Including seal and grease on goose necks and connectors

↳ Suitable Industries:

- > Construction Machinery Industry
- > Steel Structure Industry

ALUMINUM LINER CONFIGURATION

Item	Order NO.	Product Description
1-3A. CONTACT TIP (M6)	TRM035-12-08A	CuCrZr, Φ 0.8 wire (aluminium)
	TRM035-12-10A	CuCrZr, Φ 1.0 wire (aluminium)
	TRM035-12-12A	CuCrZr, Φ 1.2 wire (aluminium)
	TRM035-12-14A	CuCrZr, Φ 1.4 wire (aluminium)
	TRM035-12-16A	CuCrZr, Φ 1.6 wire (aluminium)
	TRM035-11-08A	Copper, Φ 0.8 wire (aluminium)
	TRM035-11-10A	Copper, Φ 1.0 wire (aluminium)
	TRM035-11-12A	Copper, Φ 1.2 wire (aluminium)
	TRM035-11-14A	Copper, Φ 1.4 wire (aluminium)
	TRM035-11-16A	Copper, Φ 1.6 wire (aluminium)
1-3B. CONTACT TIP (M8)	TRM035-02-08A	CuCrZr, Φ 0.8mm wire (aluminium)
	TRM035-02-10A	CuCrZr, Φ 1.0mm wire (aluminium)
	TRM035-02-12A	CuCrZr, Φ 1.2mm wire (aluminium)
	TRM035-02-14A	CuCrZr, Φ 1.4mm wire (aluminium)
	TRM035-02-16A	CuCrZr, Φ 1.6mm wire (aluminium)
B. NECK LINER	TRM154-08A-XX	(Aluminium) wire Φ 0.8-0.9mm
	TRM154-12A-XX	(Aluminium) wire Φ 1.0-1.2mm
	TRM154-16A-XX	(Aluminium) wire Φ 1.4-1.6mm
C. WIRE GUIDE BUSHING	TRM602W-061JS-11	Wire guide bushing(Φ 0.8mm- Φ 1.6mm)
E. LINER(Euro type)	TRM153B-10A-23	(aluminium) wire Φ 0.8-0.9mm
	TRM153B-12A-23	(aluminium) wire Φ 1.0-1.2mm
	TRM153B-16A-23	(aluminium) wire Φ 1.4-1.6mm
E-1. LINER (Panasonic/Lincoln connector optional)	TRM150N-08A-23	(aluminium) wire Φ 0.8-0.9mm
	TRM150N-12A-23	(aluminium) wire Φ 1.0-1.2mm
	TRM150N-16A-23	(aluminium) wire Φ 1.4-1.6mm

* If the cable length exceeds 2 metres, please contact sales in advance when ordering the length of the wire feeder tube.

Pneumatic Cleaning Station SC220A SE



Wire cutting ability Solid wire: max1.6mm
Flux-cored wire: max 3.2mm
Pneumatic motor About 650rpm / maximum torque 8N.m



1-1



1-2



1-3



1-4



1-5

ORDER GUIDE

1-1.PNEUMATIC CLEANING STATION

Order NO.	Product Description
SC220ASE-Z2	Used for robot torch to remove spatters and cut off excessive welding wire(Height 1070mm)

1-2.PNEUMATIC CLEANING STATION

Order NO.	Product Description
SC220ASE	Used for robot torch to remove spatters and cut off excessive welding wire(Height 330mm)



1-3.ANTI-SPATTER LIQUID

	Product Description
SC221A-PS	Anti-spatter liquid 250ml
SC200A-PS	Anti-spatter liquid 500ml



1-4.WIRE CUTTER

Order NO.	Product Description
SC200A-JS	Cut off excessive welding wire



1-5.REAMER

Order NO.	Product Description
ANC-0907-40	Suitable for nozzle inner dia. 10, contact tip outer dia. 6
ANC-1007-40	Suitable for nozzle inner dia. 11, contact tip outer dia. 6
ANC-1107-40	Suitable for nozzle inner dia. 12, contact tip outer dia. 6
ANC-1207-40	Suitable for nozzle inner dia. 13, contact tip outer dia. 6
ANC-1209-40	Suitable for nozzle inner dia. 13, contact tip outer dia. 8
ANC-1309-40	Suitable for nozzle inner dia. 14, contact tip outer dia. 8
ANC-1409-40	Suitable for nozzle inner dia. 15, contact tip outer dia. 8
ANC-1509-40	Suitable for nozzle inner dia. 16, contact tip outer dia. 8
ANC-1210-40	Suitable for nozzle inner dia. 13, contact tip outer dia. 9
ANC-1310-40	Suitable for nozzle inner dia. 14, contact tip outer dia. 9
ANC-1410-40	Suitable for nozzle inner dia. 15, contact tip outer dia. 9
ANC-1510-40	Suitable for nozzle inner dia. 16, contact tip outer dia. 9
ANC-1411-40	Suitable for nozzle inner dia. 15, contact tip outer dia. 10
ANC-1511-40	Suitable for nozzle inner dia. 16, contact tip outer dia. 10
ANC-1611-40	Suitable for nozzle inner dia. 17, contact tip outer dia. 10
ANC-1711-40	Suitable for nozzle inner dia. 18, contact tip outer dia. 10
ANC-1713-40	Suitable for nozzle inner dia. 18, contact tip outer dia. 12
ANC-1813-40	Suitable for nozzle inner dia. 19, contact tip outer dia. 12
ANC-1913-40	Suitable for nozzle inner dia. 20, contact tip outer dia. 12

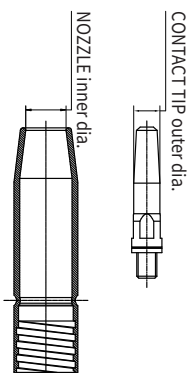

*For more reamer model, please contact our sales staff.