

FRONT VIEW

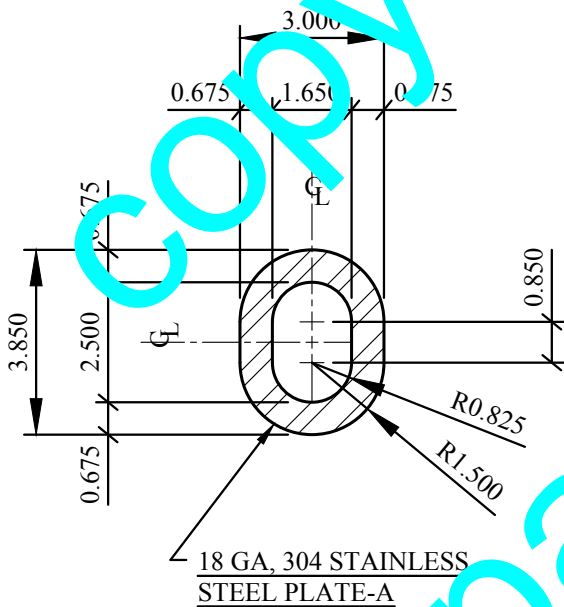

**EXTERNAL BRAKE / CLUTCH
PEDAL ROD BOOT**



FRONT VIEW

PATENT PENDING

◇			
◇1	5/6/16	KWH	REVISED NOTES
REV	DATE	BY	DESCRIPTION

DETAILS OF: EXTERNAL BRAKE / CLUTCH PEDAL ROD BOOT
 FOR JJSRODS.COM
 LOCATION WINGATE, NC
 DESIGNER JEFF JOHNSON
 DEVELOPER JEFF JOHNSON
 DRAWN 05/05/16 BY HOWELL DETAILING SERVICE, INC

PART NOTES:

1. SCALE: 3" = 1'-0", (UNO).
2. ALL DIMENSIONS ARE SHOWN IN INCHES.

PART #

JJS-32341916-1