

UPS Remote Status Panel

Description:

UPS Remote Status Panel (URSP) is used to remotely monitor the alarm condition and real time state of any UPS. The URSP is wall mounted and can be located up to 1,000 feet from the UPS. The panel uses LED's to visually display the monitored UPS input status, the output that is being used and any UPS fault conditions. The URSP also has an audible alarm to warn of UPS fault conditions.

UPS AC Input	UPS Charger / Rectifier	UPS System Batteries	UPS Inverter
UPS Output	Load on Bypass	UPS Fault	UPS Overload
UPS Input Failure	UPS Low Battery	Audible Alarm Silenced	Battery BU Status

Assembly Overview

- ◆ Remotely monitor UPS systems from up to 1,000 ft.
- ◆ Visual indication with audible alarm
- ◆ Internal battery backup
- ◆ Powder coat finish
- ◆ ETL listed to UL 1778 and CSA certified

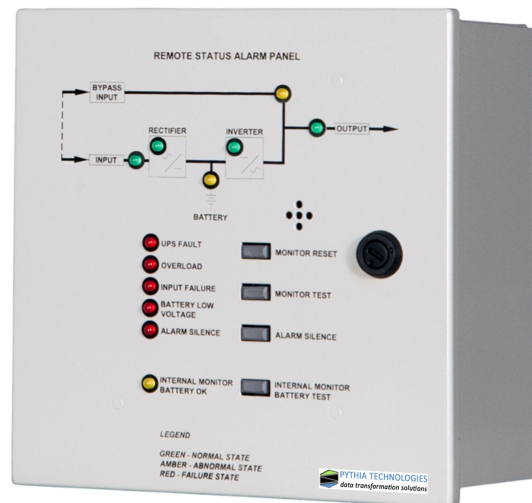

Assembly

CS0-UPS

External Power Supply Adapter

Dimensions

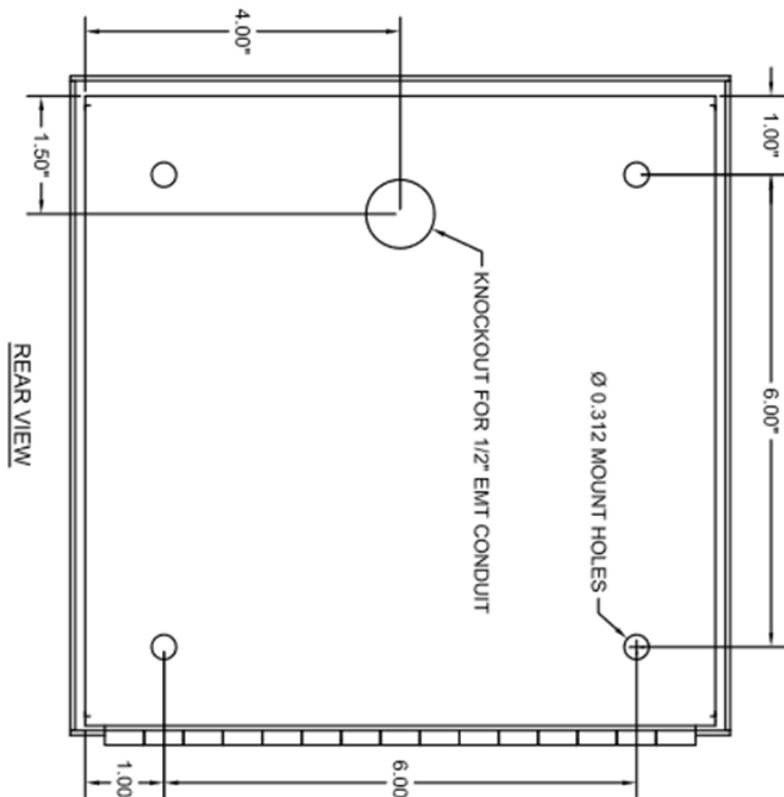
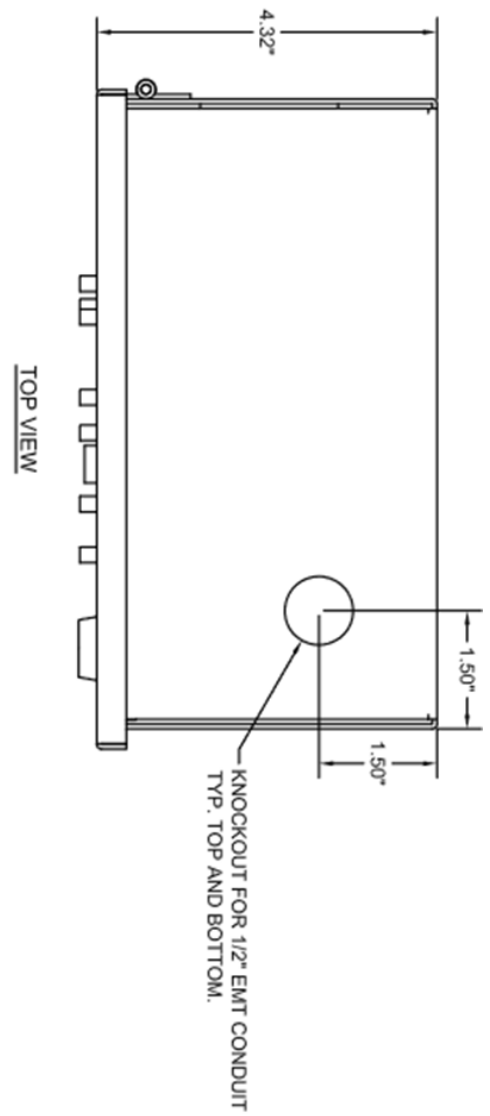
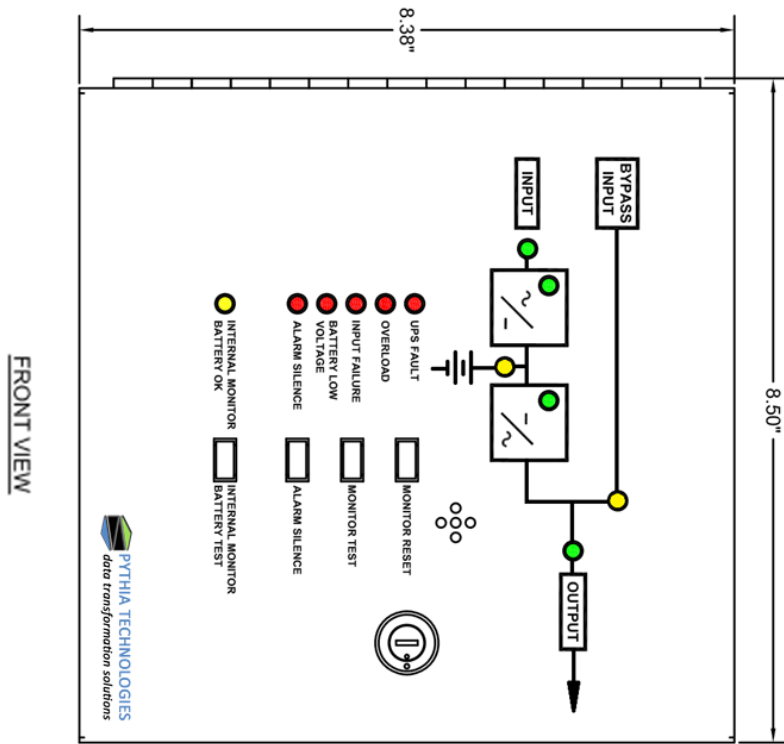

Connections

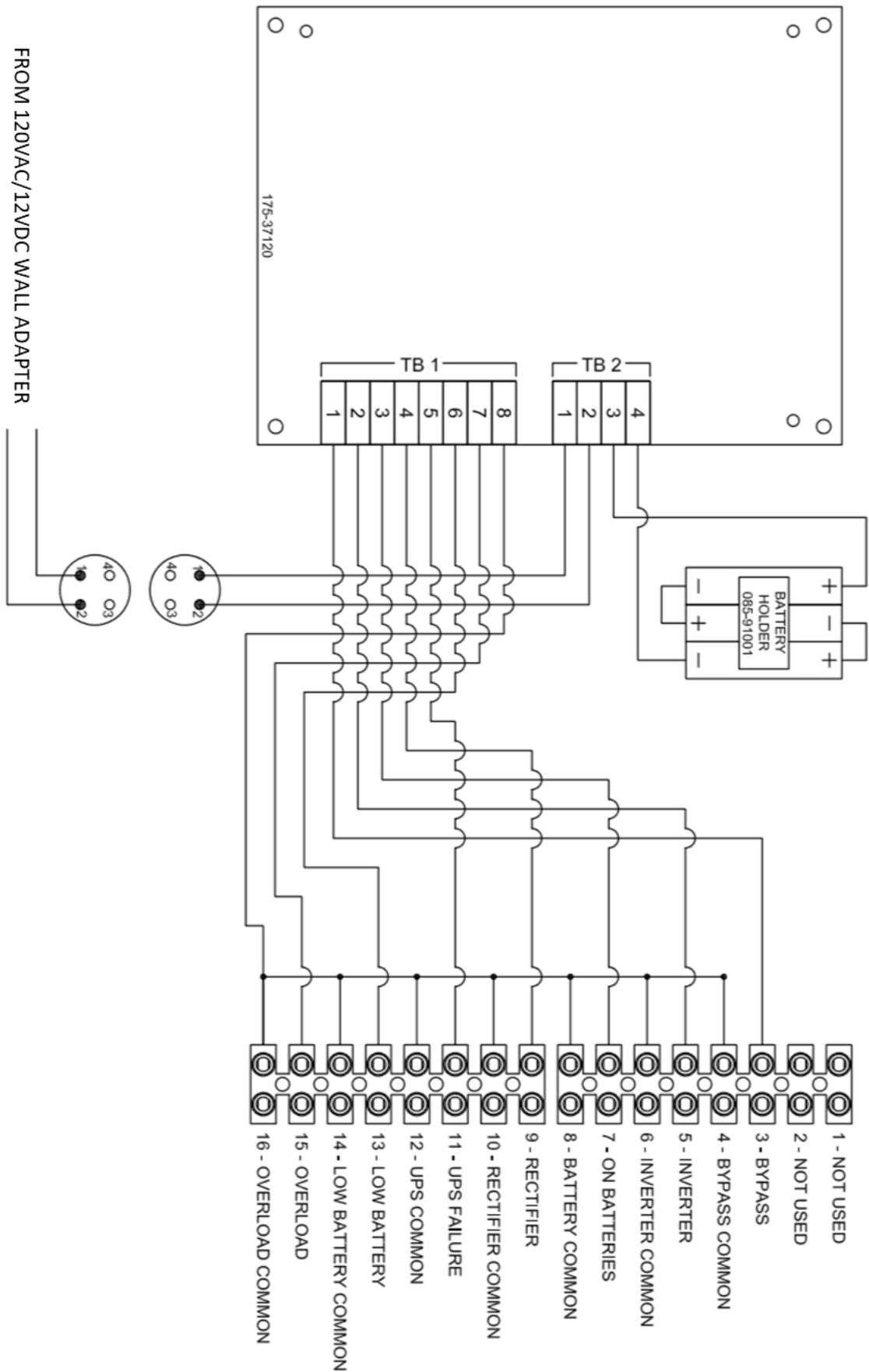

Key Features:

Monitor all UPS critical alarms

Remote contacts can be 1000 feet away

Audible and Visual indicators of Alarms

Battery backed up for extended uptime

UL and CSA Listed

SPECIFICATIONS

Communications	None
Alarm Inputs	7
Input Type	Dry-contact only / zero voltage relays or contacts
Dimensions	8.4" x 8.5" x 4.35"
Weight	6.0lbs
Certification	UL 1778, CSA

Other Specifications

none

Ordering

CS0-UPS

Call for alternative assembly pricing



PYTHIA TECHNOLOGIES
data transformation solutions

175 S. Sandusky Street, Suite 321 Delaware OH 43015 Tel. 614.363.2272 Fax 740.693.8409

Sales@pythiatech.com

© 2018 Pythia Technologies, Inc.

All rights reserved throughout the world.

Specification may change at anytime without notice.

Document #: SPEC_CS0-UPS_001_0818