

PONYSHOES QUICK SET UP AND RULES GUIDE

Please visit the website at www.ponyshoesgame.com

GAME SET UP

- PLACE GAME BOARD ON EDGE SO SLOTS ARE VERTICAL AS SHOWN IN DIAG. A.
- INSERT LEGS INTO SLOTS.
- SWIFTLY ROTATE UPRIGHT

DIAGRAM A

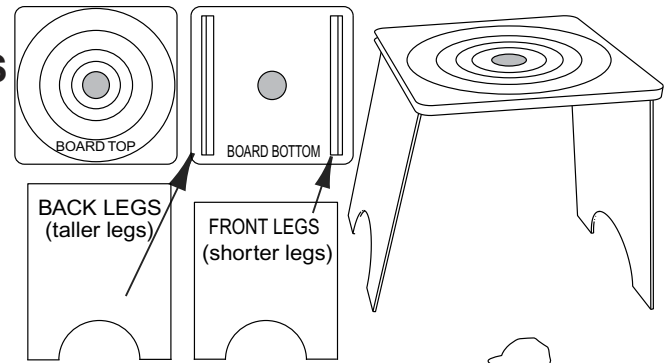

GAME PLAY

- PONYSHOES IS PLAYED WITH 2 OR 4 PLAYERS AND CAN BE PLAYED ON 1 OR 2 BOARDS.
- 4 PLAYER GAMES ARE BEST WITH A 2 BOARD SET-UP.

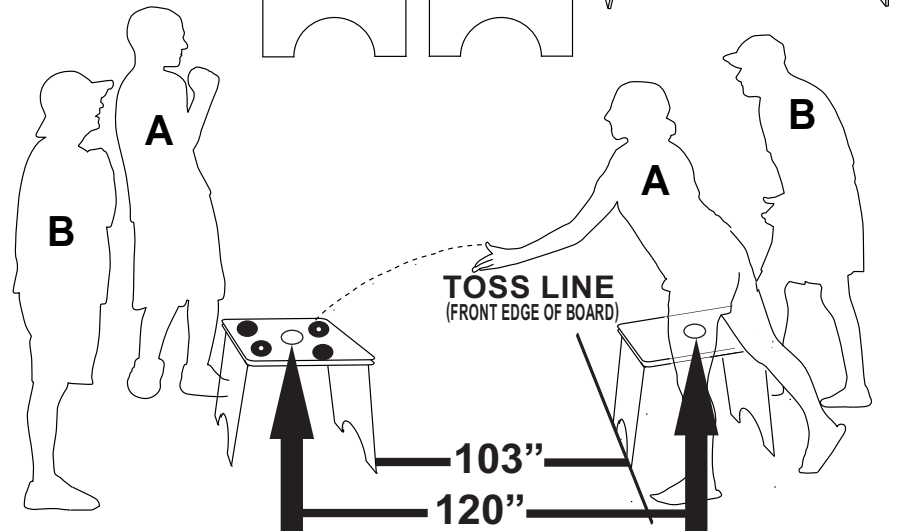

REGULATION TOURNAMENT DISTANCE IS 120" CENTER TO CENTER ON HOLES.

For single game board, REGULATION DISTANCE IS 103" FROM TOSS LINE TO FRONT.

SCORING

- PONYSHOES IS SCORED LIKE HORSESHOES WITH ALTERNATE SHOTS AND CAN BE PLAYED TO 11 OR 21, WIN BY 2.
- ONLY 1 TEAM OR 1 PLAYER CAN SCORE POINTS PER ROUND, PUCKS ARE TOSSED 2 PER TEAM OR PER PERSON WITH ALTERNATE SHOTS. A FLIP OF A COIN OR TOSS 1 PUCK EACH AND THE CLOSEST DETERMINES WHO GOES 1ST.
- 1,2,3,4 OR 6 POINTS CAN BE SCORED BY 1 TEAM PER ROUND

THE PLAYERS FEET MUST REMAIN BEHIND THE FRONT EDGE OF THE BOARD WHEN TOSSING THE SHOE.

