

FIRE DISTRICT RESIDENTIAL ACCESS & WATER SUPPLY PERMIT INFORMATION

- RESIDENTIAL ACCESS & WATER SUPPLY PERMIT APPLICATION FOR LOTS CREATED BY AN ADMINISTRATIVE LAND DIVISION. (LIMIT 4 LOT SUBDIVISION)
- Subdivisions of 5 lots or more shall meet access and water supply requirements of the 2018 IFC regardless of house size.

Access Road Guidelines

Privately maintained Roadway Width, Surface and Turnaround Requirements:

- All access roads serving dwellings shall have a minimum improved driving surface width of 20 feet.
- All roads and bridges shall be designed to meet a 75,000 lb fire apparatus load. Roads and bridges shall be inspected and certified by the applicant's engineer prior to obtaining a certificate of occupancy.
- If the access road exceeds 150 feet in length then a turnaround is required to be placed within 150 feet of the dwellings. See turnaround examples below.
- A vertical clearance of 13 feet 6 inches is required over the width of the access road.
- Existing driveways that add a second residence shall meet the minimum requirements of 4" thick ¾ minus gravel base or equivalent recycled asphalt paving (RAP), graded and compacted with a 20 foot wide all weather driving surface.
- New driveways shall provide a subbase if longer than 150 feet. The subbase shall be 9" of uncrushed aggregate (pit-run). The base shall be 4" thick ¾ minus gravel base or equivalent recycled asphalt paving (RAP), graded and compacted with a 20 foot wide all weather driving surface.
- Driveways serving two (2) properties and all private roads shall have a recorded road users maintenance agreement that describes the responsible parties for construction and maintenance, including repairs, and necessary improvements to accommodate additional accesses in the future. The agreement shall also list any construction warranties applicable to the specific driveway or privateroad.

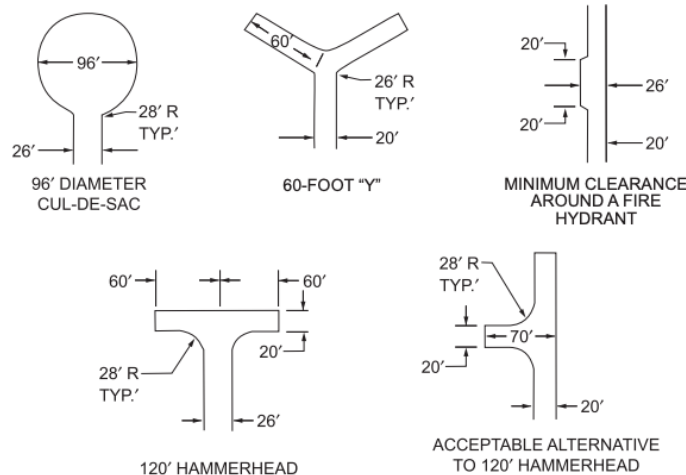

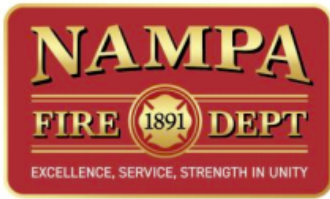

FIRE DISTRICT RESIDENTIAL ACCESS & WATER SUPPLY PERMIT INFORMATION

WATER SUPPLY FOR FIRE SUPPRESSION

Fire flow square footage is determined by total occupiable space under the roof deck, including garages, bonus rooms, basements, and exterior porches/patios. (Building plans may be required for review to calculate the actual square footage). Dwellings over 3,600 SF are required to have approved fire suppression water supply.

The following are the only approved water supply options:

Municipal Water System- A fire hydrant, supplied by a municipal water system capable of the required fire flow per 2018 International Fire Code, Appendix B.

Private and/or Community Well- A fire hydrant, supplied by a private and/or community water system, located within 1,200 feet driving distance of the residence. The hydrant shall be capable of supplying the required fire flow for the structure. To be considered as a water supply the owner/applicant will be required to provide fire flow information from the water purveyor that verifies the well is capable of the required fire flow.

Elevated and Pressure Tanks- A fire hydrant, supplied by a tank with a water capacity of 180,000 gallons, located within 1,200 feet driving distance of the residence.

NFPA 13D Fire Sprinkler System- In lieu of the water systems above an NFPA 13D fire sprinkler system may be installed in the residence. Plans for the design of the fire sprinkler system are required to be submitted to the fire jurisdiction for review and approval. Installation inspections of the system will be carried out by the fire jurisdiction.



Middleton Rural Fire District
Star Fire Protection District

Victor Islas

DEPUTY CHIEF

Fire District Headquarters
11665 W. State St.
Star, Idaho 83669

Office: (208) 563-0121
Mobile: (208) 860-1078
vislas@starfirerescue.org



FIRE DISTRICT RESIDENTIAL ACCESS & WATER SUPPLY PERMIT APPLICATION

PAGE 1 TO BE COMPLETED BY APPLICANT

Date:

Contractor:	Contact:	<input type="checkbox"/> Owner Build
Address:	City:	Zip:
Phone/Mobile:	Email Address:	
Owner(s):		
Address:	City:	Zip:
Phone/Mobile:	Email Address:	

PROJECT INFORMATION

Site Address:			
Parcel Number:	Subdivision:	Lot:	Block:
Total Acers:	Total Sq. Ft.:	Stories Above Grade:	Stories Below Grade:
<input type="checkbox"/> Home is located on 5+ acers outside of impact area. (Idaho Administrative Procedure Act. Title 41, Chapter 2, 41-253)			

ACCESS/ROAD	WATER SUPPLY
<p>A site plan is required for each permit application</p> <p><input type="checkbox"/> Home is in a platted subdivision (provide plat plan):</p> <p>Show on your site plan how you will comply with the access requirements found on page of the application.</p> <p>Length: _____ Width: _____ Turning Radius: _____</p> <p>Vertical Clearance: _____ Grade: _____</p> <p>Turnaround: <input type="checkbox"/> Yes <input type="checkbox"/> No Bridges: <input type="checkbox"/> Yes <input type="checkbox"/> No</p> <p>Electric Gate: <input type="checkbox"/> Yes <input type="checkbox"/> No Surface: _____</p>	<p>Minimum fire suppression water supply requirements:</p> <p><input type="checkbox"/> Less than 3,600 sq. ft. - No additional water supply required.</p> <p><input type="checkbox"/> Over 3,600 sq. ft. one of the following options is required:</p> <ul style="list-style-type: none"> <input type="checkbox"/> Municipal Water Supply <input type="checkbox"/> Elevated Tank <input type="checkbox"/> Pressure Tank <input type="checkbox"/> Pond built per NFPA 1142 <input type="checkbox"/> Private/Community Well providing the required fire flow. <input type="checkbox"/> NPFA 13D Fire Sprinkler System installed in residence. <input type="checkbox"/> AHJ alternative method accepted. <p><i>*Note: Separation through construction will not be accepted.</i></p>

APPLICANT COMMENTS

APPLICANT SIGNATURE

**By signing this application, the owner/applicant agrees to the statements made on this application:*

Owner/Applicant Signature:	Date:
----------------------------	-------