

ARIZONA | SHOWER DOOR

Original Euro Curved Slider Installation

The Euro Curved Slider requires an additional ZV927 bumper installed with one #6 x 1/4" screw provided where the bottom hump of the outside panel will make contact with the ZTE1203 wall jamb. An optional bumper and screw is also provided for the top if needed.

(Drill a 1/8" pilot hole to attach screw.)

** The curve stays the same direction as image bellow

*** The inside panel is determined by the showerhead location

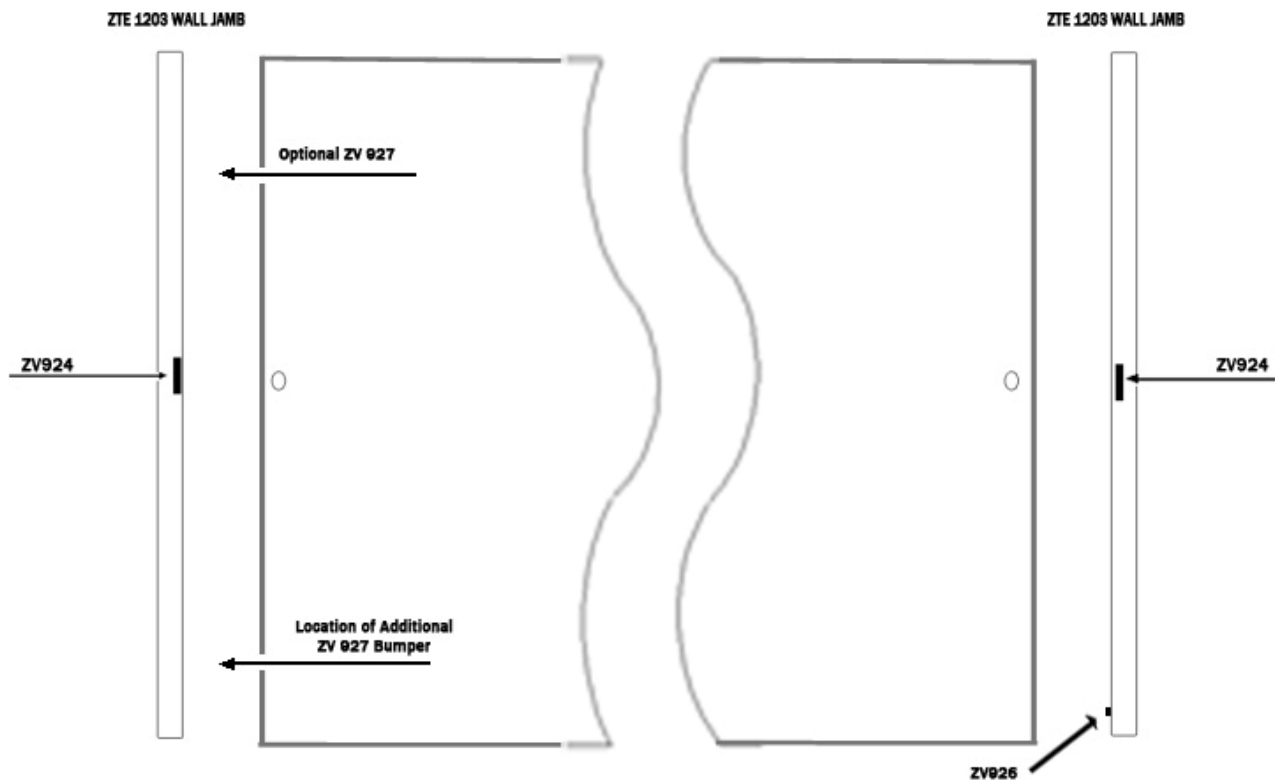

ARIZONA | SHOWER DOOR

New Euro Curved Slider Installation Notes

The Euro Curved Slider requires two additional ZV927 bumper installed with one #6 x 1/4" screw provided where the bottom hump of the inside panel and the top hump of the outside panel will make contact with the ZTE1203 wall jamb.

**The curve stays the same direction as image below

*** The inside panel is determined by the showerhead location

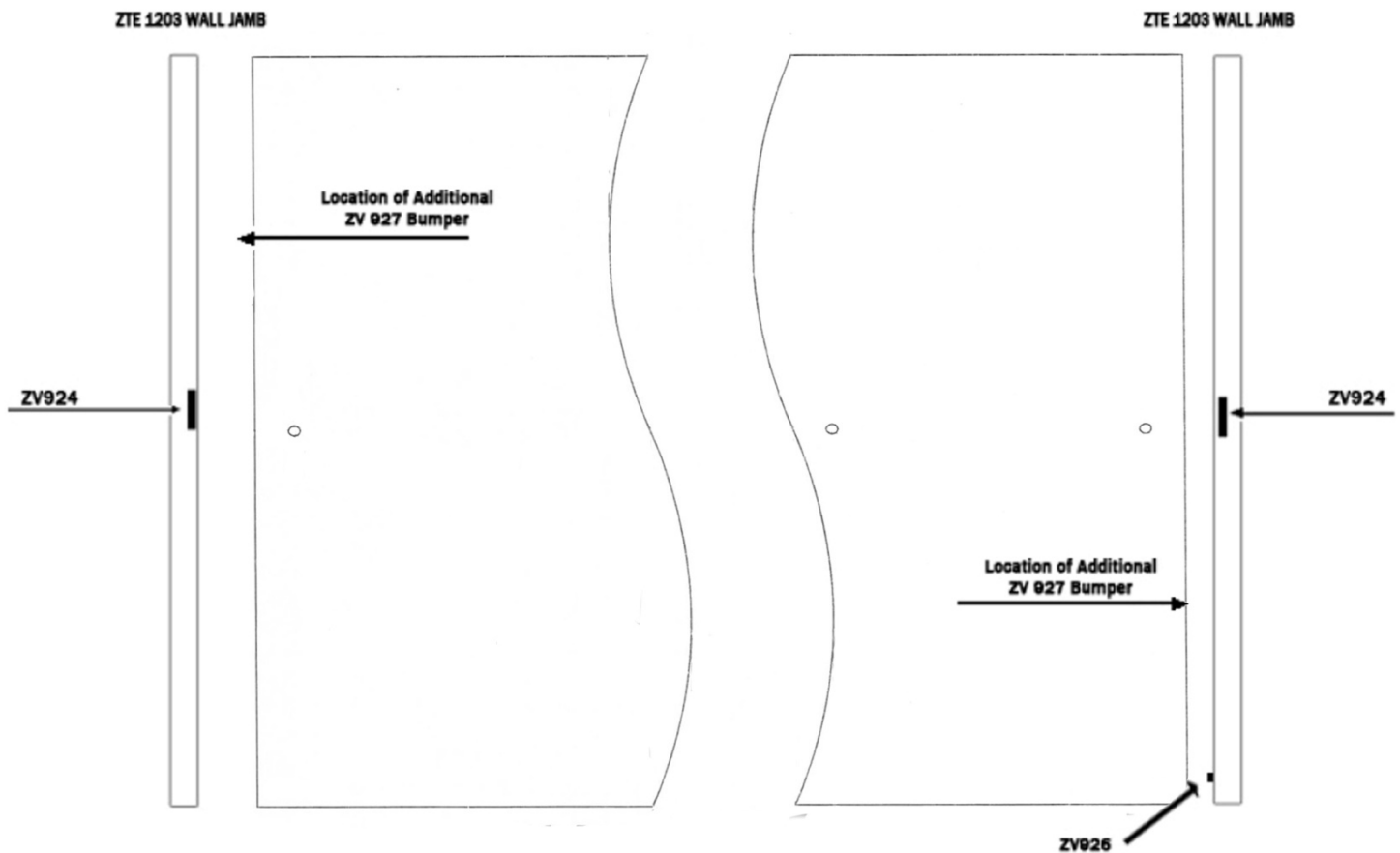

INSTALLATION INSTRUCTIONS

Model
ETE/ESE-1/4

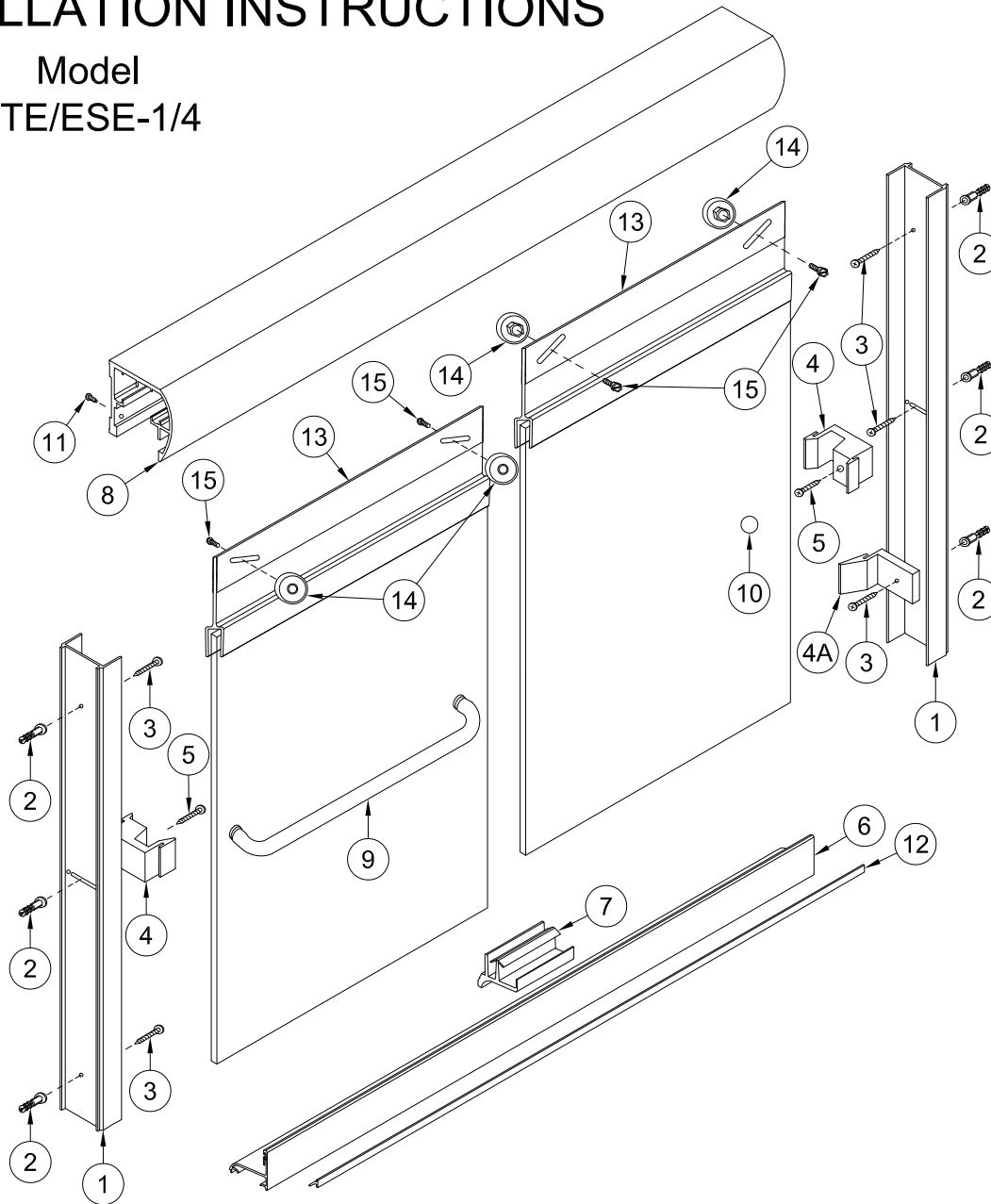

#	Description	Qty	Part #	Picture
1	Wall Jamb	2	ZTE-1203	
2	Screw Anchor	6	ZV-935	
3	#8X1 1/4 Pan Head Screw	6		
4	Bumper	2	ZV-924	
4A	Bottom Bumper	1	ZV-926	
5	#6/32X1/2 Machine Screw	2		
6	Curb	1	ZTE-1222	
7	Center Guide	1	ZV920-3	
8	Header	1	ZTE-1601	
9	Towel Bar	1	ASD24T	
10	Pull Handle	1	ASD1	
11	#6X3/8 Pan Head Screw	2		
12	Curb Vinyl	1	ZV-918	
13	Full Top Rail	2	ZTE-3214	
14	Roller Wheel	4	ZA-99	
14	#8/32x3/8 CH	4		

When ordering replacement parts, please provide the following information:

1. Part Number
2. Part Name
3. Model Number
4. Specify design (if any)

To install your Shower Enclosure you will need the following:

- Level
- 1/8" and 9/64" Drill Bits
- (Tile) 3/16" Masonary Bit
- Phillips Screwdriver
- Sealant
- Hack Saw

Arizona Corporate Office
2801 W. Indian School Rd
Phoenix, AZ 85017
800-255-1901 PH
602-447-8208 FAX

Florida
8100-1 Westside Industrial Dr
Jacksonville, FL 32219
855-695-8899 PH
904-786-9025 FAX

Illinois
2601 Bond St #1
University Park, IL 60484
800-861-6120 PH
708-235-0729 FAX

Oregon
2057 Lars Way
Medford, OR 97501
866-773-7905 PH
541-773-7909 FAX

Colorado
3871 Revere Street
Denver, CO 80239
866-574-1766 PH
303-574-1775 FAX

Utah
2594 S. 3600 West Suite A
West Valley City, UT 84119
877-402-5007 PH
801-972-3111 FAX

ARIZONA SHOWER DOOR

Tools you will need for this install

- ✓ Exploded View drawing of shower door
- ✓ 3/16" Masonry drill bit (use 9/64" drill bit for fiberglass)
- ✓ 1/8" drill bit
- ✓ Drill
- ✓ 4' Level
- ✓ Saw (Electric Chop saw or Hacksaw)
- ✓ Side cutting pliers
- ✓ #2 Phillips drill bit
- ✓ #2 Phillips screwdriver
- ✓ Tape Measure
- ✓ Pencil or Pen
- ✓ Caulking Gun
- ✓ 1-Tube of 100% Clear Silicone (no latex!)
- ✓ Vacuum Cleaner or Brush for clean up
- ✓ Glass Cleaner and Paper Towels
- ✓ Rubber Mallet
- ✓ File

INSTALLATION INSTRUCTIONS
FOR

MODEL ETE-1/4/ESE-1/4

Note: These instructions will refer to the item #'s in the Exploded View drawing. For example, #1, #2, #3 etc...
Please read through **all** of the instructions to get an over-view **before** you install the door.

1) Find the centerline of where the unit will be installed. This will usually be the center of the ledge of the bath tub or the curb of the shower pan. Place a centerline mark at each end of the tub ledge or curb where it meets the wall. This mark will also represent the center of the ZTE1203 wall jamb (item #1 in exploded view). Place the wall jamb against the wall and on top of the ledge or curb aligning centerline marks. If your shower is fiberglass you might have to file the backside corner of the ZTE1203 to a radius so the jamb sits as flush as possible on the ledge or curb. Use a level to position the jamb plumb, then mark the installation holes with a pen or pencil. Repeat this procedure for the other jamb. Now drill the 6 holes with a 3/16" masonry bit (9/64" for fiberglass, & without anchors). Then insert the 6)-ZV935 screw anchors (#9) in the holes. Fasten the ZTE1203 wall jambs in place using the #8X1-1/4 Phillips Pan Head screws provided (#3). **Important Note:** The ZV926 Bottom Bumper (#4A) needs to be installed with the bottom screw on the jamb, on the showerhead side of the unit, with the angled side of the bumper going to the inside of the shower. Refer to the exploded view. Attach

the ZV924 Bumpers (#4) using the 2-#6/32X1/2 Machine screws (#5) keeping in mind that the inside panel will be on the showerhead side of the shower.

2) Measure the distance between the inside of the wall jambs (just above the tub ledge or curb). Measure tight and deduct 1/16" to 1/8" to get the cut size of the ZTE1222 Curb (#6). Cut to size. Apply silicone where wall jambs meet tub or curb. Then run a bead along the underneath of the ZTE1222 Curb. Slide the curb down between the wall jambs and onto the tub/shower. Make sure the curb is solid and doesn't rock back and forth. If it is not solid secure it with two of the #6X3/8" Pan Head Screws (#13) provided by drilling with a 1/8" drill bit through the outside leg of the wall jamb at the bottom, into the face of the curb and inserting the screws.

3) Measure the distance from wall to wall across the top of the jambs. Cut the ZTE1601 Header (#8) to that dimension minus -1/16". Slide the header down over the top of the wall jambs. The header does not need to be secured with screws.

4) Setting of the glass. The inside panel will be set first. This will be done as you stand on the **outside** of the shower. Grip one of the panels on each side so that the rollers are facing **away** from you. Lift the panel so that the bottom edge of the glass clears the top of the ZTE1222 Curb as you lower it into the shower. **Do not set the glass down on its edge. Be very careful to not hit the edge on anything.** Continue lowering the panel down

until the top rollers can be guided up into the inside roller track of the header. Lift up glass then slowly lower the rollers into the inside roller track and let the panel hang in its vertical position. The outside panel will be installed the same way. Make sure the rollers are facing **to-ward** you. A helper would be valuable at this point to hold the inside panel on an angle toward the inside so that the outside panel can be lowered and positioned to be installed into the outside roller track. The inside panel will be positioned at the showerhead side of the shower while the outside panel will be positioned opposite the showerhead. This is to ensure that no water escapes through the overlap.

5) Adjust Rollers. The roller wheels are mounted to angled slots in the top rail on the glass. Lowering the roller in the slot raises the glass. Raising the roller in the slot lowers the glass. Start out with the rollers mounted in the middle of the angled slot. If the panel needs to be adjusted you can remove the panel, adjust with a screwdriver then, reset the panel. This might be done one or two times until you achieve proper alignment. The end result should be that the vertical edge of the panel is parallel to your wall jamb to achieve maximum coverage.

6) Attach the ZV920 Center Guide (#7). Slide both panels to one end. The front lip of the guide slips into the slot on the inside of the

front edge of the ZTE1222 Curb. Position the guide just to the side of the panels, slip the front lip in, then snap the guide down over the inside of the curb. Slide the guide over carefully. When the doors are in a closed position the center guide should be centered in the overlap of the glass. For added security you can attach the guide after it is snapped in place by drilling with a 1/8" drill bit through the snap in leg into the curb(from the inside of the shower) then running a #6X3/8 screw into the hole.

7) Attach the ASD-1 (#10) Knob Pull by inserting the threaded bolt with grommet through the hole. This will be the inside panel with one hole which will be on the showerhead side of the opening. The knob should be on the inside. Also make sure the plastic washers provided are on each side of the glass. Use the small Allen wrench provided to insert into the small hole on the bolt head. Turn and tighten the bolt until the knob is secure. Over tightening can cause the glass to blow up.

8) Attach the towel bar on the outside panel with two holes using the same method as the knob in step 7.

9) Run a bead of silicone on the gap between the metal and the shower surface inside and out. Fill all joints and gaps where metal meets metal and fill with a fine bead.

INSTALLATION INSTRUCTIONS

Model LETE/LESE

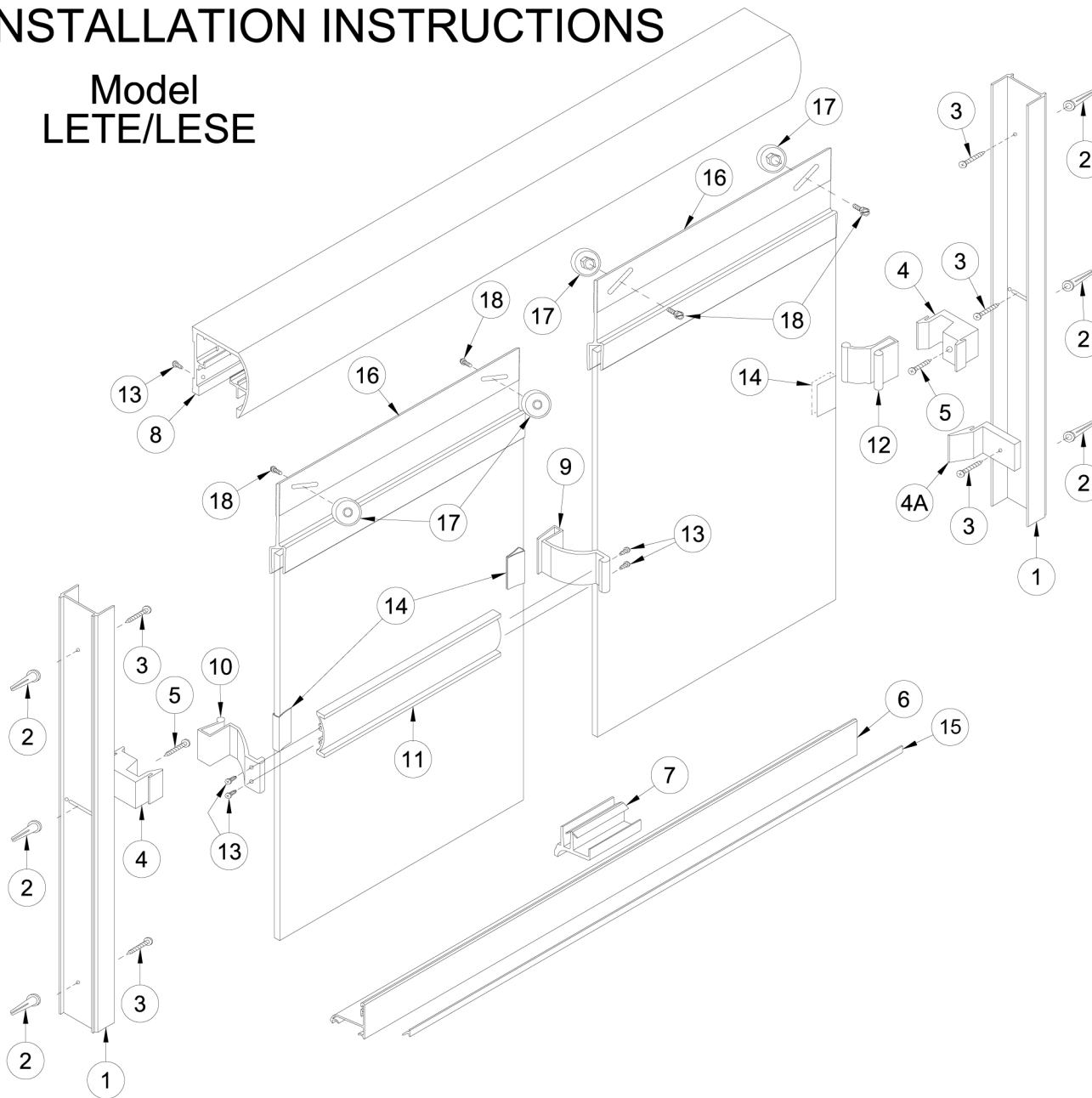

#	Description	Qty	Part #	Picture
1	Wall Jamb	2	ZTE-1203	
2	Screw Anchor	6	ZV-935	
3	#8X1 1/4 Pan Head Screw	6		
4	Bumper	2	ZV-924	
4A	Bottom Bumper	1	ZV-926	
5	#6/32X1/2 Machine Screw	2		
6	Curb	1	ZTE-1222	
7	Center Guide	1	ZV-920-3	
8	Header	1	ZTE-6201	
9	T-Bar Bracket	1	ZTE1206-1.5	
10	T-Bar Bracket w/Pull	1	ZTE1206 P-1.5	
11	Towel Bar	1	ZTE-3205	
12	Pull	1	ZTE1207-1.5	
13	#6X3/8 Pan Head Screw	6		
14	Handle Vinyl	3	ZV-916	
15	Curb Vinyl	1	ZV-918	
16	Full Top Rail	2	ZTE-3208	
17	Roller Wheel	4	ZA-99	
18	#8/32x3/8 CH	4		

When ordering replacement parts, please provide the following information:

1. Part Number
2. Part Name
3. Model Number
4. Specify design (if any)

To install your Shower Enclosure you will need the following:

- Level
- 1/8" and 9/64" Drill Bits
- (Tile) 3/16" Masonry Bit
- Phillips Screwdriver
- Sealant
- Hack Saw

Arizona Corporate Office
2801 W. Indian School Rd
Phoenix, AZ 85017
800-255-1901 PH
602-447-8208 FAX

Florida
8100-1 Westside Industrial Dr
Jacksonville, FL 32219
855-695-8899 PH
904-786-9025 FAX

Illinois
2601 Bond St #1
University Park, IL 60484
800-861-6120 PH
708-235-0729 FAX

Oregon
2057 Lars Way
Medford, OR 97501
866-773-7905 PH
541-773-7909 FAX

Colorado
3871 Revere Street
Denver, CO 80239
866-574-1766 PH
303-574-1775 FAX

Utah
2594 S. 3600 West Suite A
West Valley City, UT 84119
877-402-5007 PH
801-972-3111 FAX

ARIZONA SHOWER DOOR

Tools you will need for this install

- ✓ Exploded View drawing of shower door
- ✓ 3/16" Masonry drill bit (use 9/64" drill bit for fiberglass)
- ✓ 1/8" drill bit
- ✓ Drill
- ✓ 4' Level
- ✓ Saw (Electric Chop saw or Hacksaw)
- ✓ Side cutting pliers
- ✓ #2 Phillips drill bit
- ✓ #2 Phillips screwdriver
- ✓ Tape Measure
- ✓ Pencil or Pen
- ✓ Caulking Gun
- ✓ 1-Tube of 100% Clear Silicone (no latex!)
- ✓ Vacuum Cleaner or Brush for clean up
- ✓ Glass Cleaner and Paper Towels
- ✓ Rubber Mallet
- ✓ File

Installation Instructions for

Model LETE/LESE

Note: These instructions will refer to the item #'s in the Exploded View drawing. For example, #1, #2, #3 etc... Please read through **all** of the instructions to get an over-view **before** you install the door.

1) Find the centerline of where the unit will be installed. This will usually be the center of the ledge of the bath tub or the curb of the shower pan. Place a centerline mark at each end of the tub ledge or curb where it meets the wall. This mark will also represent the center of the ZTE1203 wall jamb (item #1 in exploded view). Place the wall jamb against the wall and on top of the ledge or curb aligning centerline marks

(A). If your shower is fiberglass you might have to file the backside corner of the ZTE1203 to a radius so the jamb sits as flush as possible on the ledge or curb. Use a level to position the jamb plumb, then mark the installation holes

with a pen or pencil **(B)**. Repeat this procedure for the other jamb. Now drill the 6 holes with a 3/16" masonry bit (9/64" for fiberglass, & without anchors). Then insert the 6)-ZV935 screw anchors (#9) in the holes. Fasten the ZTE1203 wall jambs in place using the #8X1-1/4 Phillips Pan Head screws provided (#3) **(C)**.

Important Note: The ZV926 Bottom Bumper (#4A) needs to be installed with the bottom screw on the jamb, on the showerhead side of the unit, with the angled side of the bumper going to the inside of the shower **(D)**. Refer to the exploded view. Attach

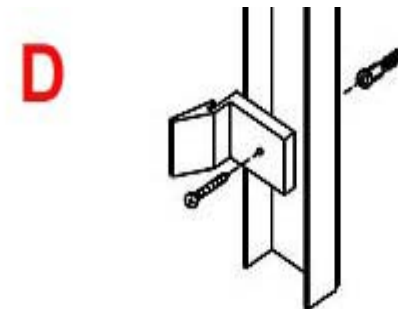
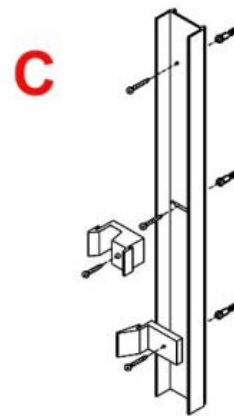
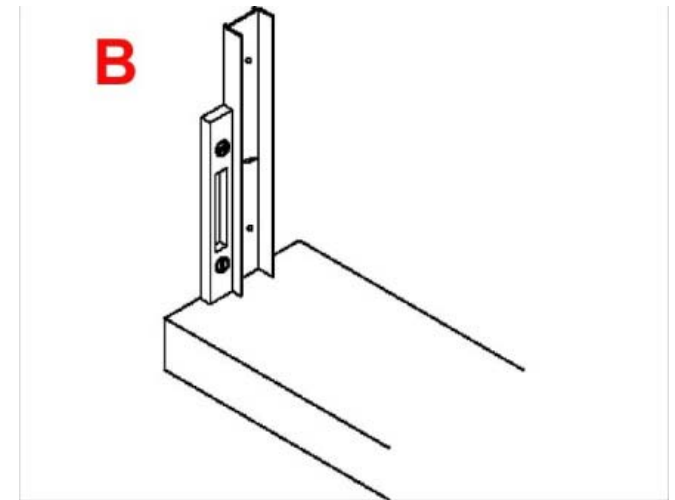
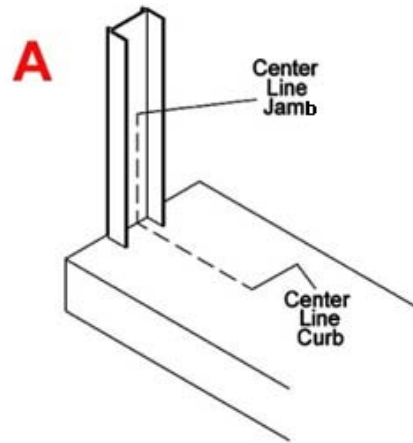

the ZV924 Bumpers (#4) using the 2-#6/32X1/2 Machine screws (#5) keeping in mind that the inside panel will be on the showerhead side of the shower.

2) Measure the distance between the inside of the wall jambs (just above the tub ledge or curb). Measure tight and deduct 1/16" to 1/8" to get the cut size of the ZTE1222 Curb (#6) **(E)**. Cut to size. Apply silicone where wall jambs meet tub or curb. Then run a bead along the underneath of the ZTE1222 Curb **(F)**. Slide the curb down between the wall jambs and onto the tub/shower. Make sure the curb is solid and doesn't rock back and forth. If it is not solid secure it with two of the #6X3/8" Pan Head Screws (#13) provided by drilling with a 1/8" drill bit through the outside leg of the wall jamb at the bottom, into the face of the curb and inserting the screws **(G)**.

3) Measure the distance from wall to wall across the top of the jambs. Cut the ZTE6201 Header (#8) to that dimension minus -1/16". Slide the header down over the top of the wall jambs. The header does not need to be secured with screws **(H)**.

4) Setting of the glass. The inside panel will be set first. This will be done as you stand on the **outside** of the shower. Grip one of the panels on each side so that the rollers are facing **away** from you. Lift the panel so that the bottom edge of the glass clears the top of the ZTE1222 Curb as you lower it into the shower. **Do not set the glass down on its edge. Be very careful to not hit the edge on anything.** Continue lowering the panel down

E

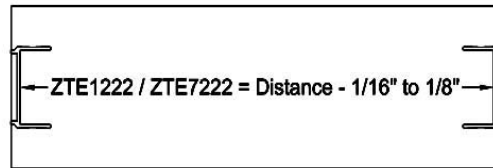

F

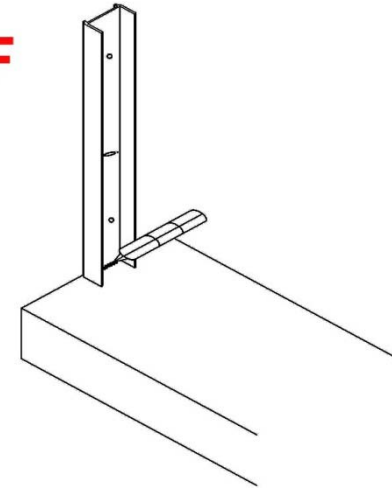

F2

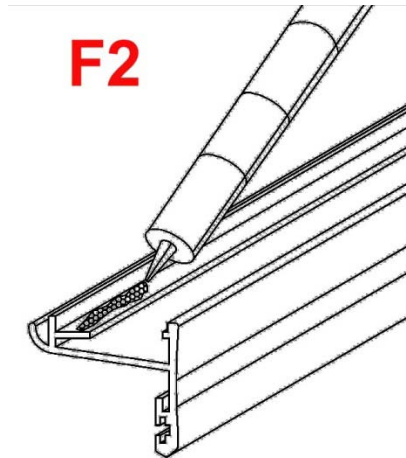

G

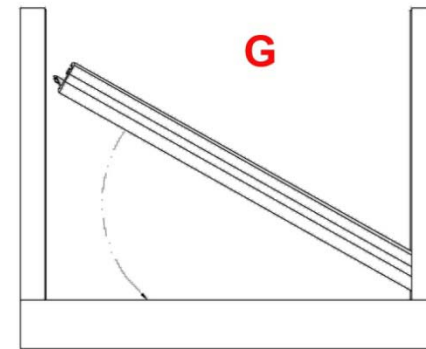

G2

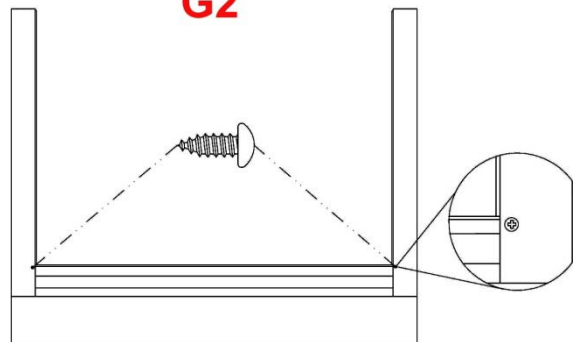

H

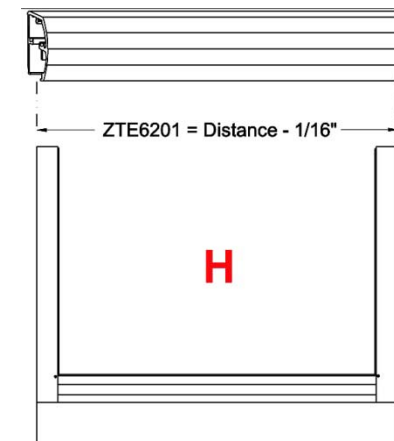

until the top rollers can be guided up into the inside roller track of the header. Lift up glass then slowly lower the rollers into the inside roller track and let the panel hang in its vertical position. The outside panel will be installed the same way. Make sure the rollers are facing **to-ward** you. A helper would be valuable at this point to hold the inside panel on an angle toward the inside so that the outside panel can be lowered and positioned to be installed into the outside roller track. The inside panel will be positioned at the showerhead side of the shower while the outside panel will be positioned opposite the showerhead. This is to ensure that no water escapes through the overlap **(I)**.

5) Adjust Rollers (J). The roller wheels are mounted to angled slots in the top rail on the glass. Lowering the roller in the slot raises the glass. Raising the roller in the slot lowers the glass. Start out with the rollers mounted in the middle of the angled slot. If the panel needs to be adjusted you can remove the panel, adjust with a screwdriver then, reset the panel. This might be done one or two times until you achieve proper alignment. The end result should be that the vertical edge of the panel is parallel to your wall jamb to achieve maximum coverage.

6) Attach the ZV920 Center Guide (#7). Slide both panels to one end. The front lip of the guide slips into the slot on the inside of the

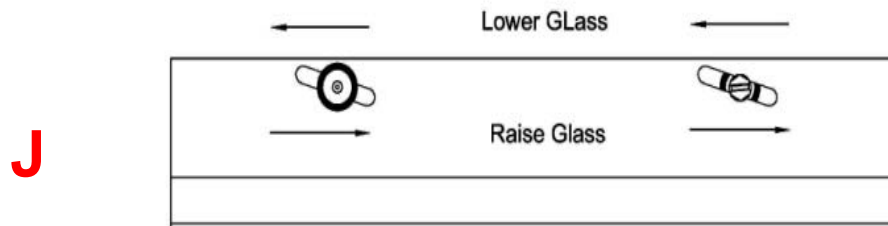
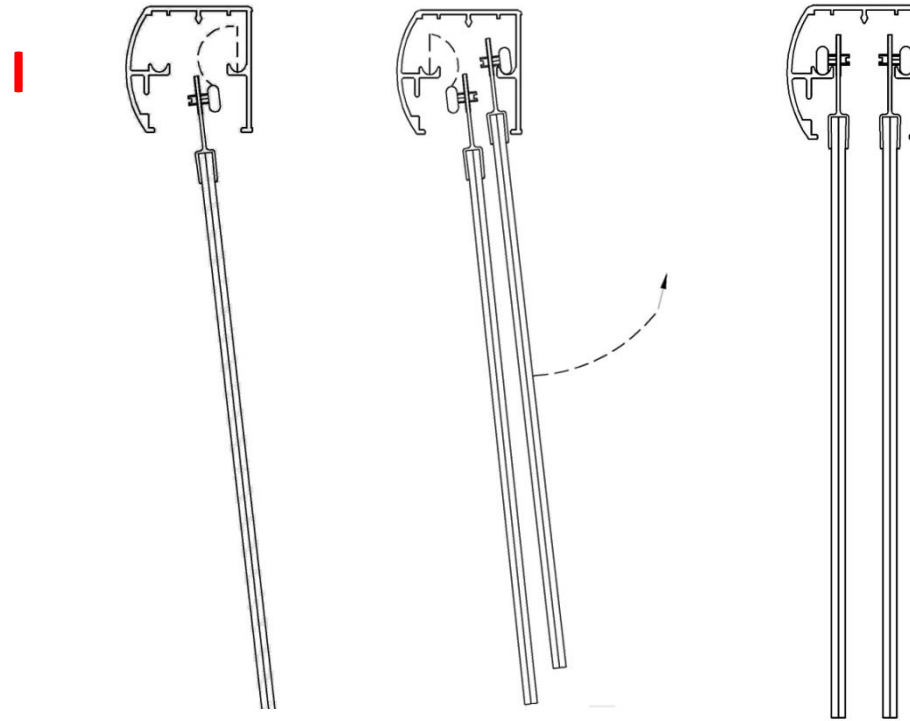

front edge of the ZTE1222 Curb. Position the guide just to the side of the panels, slip the front lip in, then snap the guide down over the inside of the curb. Slide the guide over carefully. When the doors are in a closed position the center guide should be centered in the overlap of the glass **(K)**. For added security you can attach the guide after it is snapped in place by drilling with a 1/8" drill bit through the snap in leg into the curb(from the inside of the shower) then running a #6X3/8 screw into the hole.

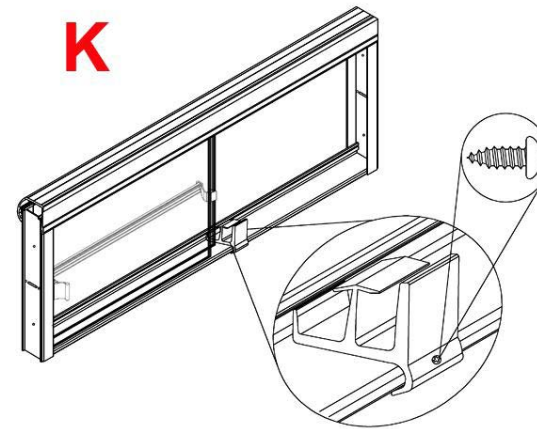

7) Attach the Handle **(L)** ZTE1207-1.5 (#12) by placing the Handle Gasket ZV916 (#14) over the edge of the glass aligning it with the middle wall jamb bumper (ZV924) on the shower head side panel. Then place the handle over the gasket and gently tap onto the glass with a rubber mallet.

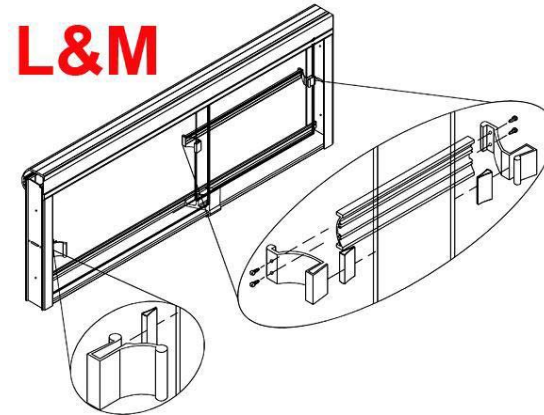

8) Attach the Towel Bar **(M)** using the ZTE1206-1.5 (#9) and the ZTE1206P-1.5 (#10) Brackets. Follow the same procedure as step 7 aligning the brackets with the middle wall jamb bumper. The 1206P will be used on the wall jamb side of the towel bar while the 1206 will go on the overlap side. After you attach the brackets slide the Towel Bar ZTE3205 (#11) into the brackets and secure with 4-#6X3/8 screws.

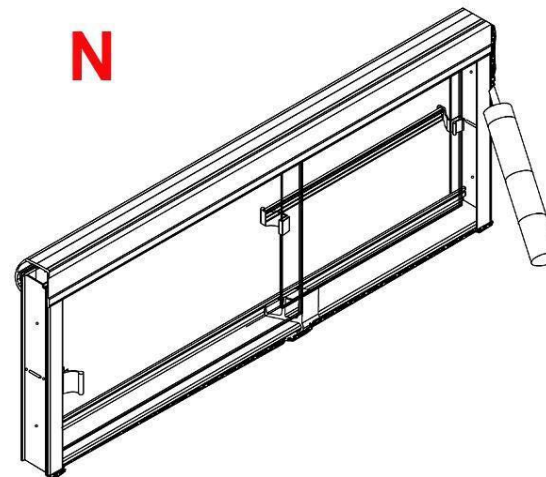

9) Run a bead of silicone on the gap between the metal and the shower surface inside and out. Fill all joints and gaps where metal meets metal and fill with a fine bead. **(N)**

INSTALLATION INSTRUCTIONS

Model
LETET/LESET- 3/16"
LETER/LESER- 1/4"

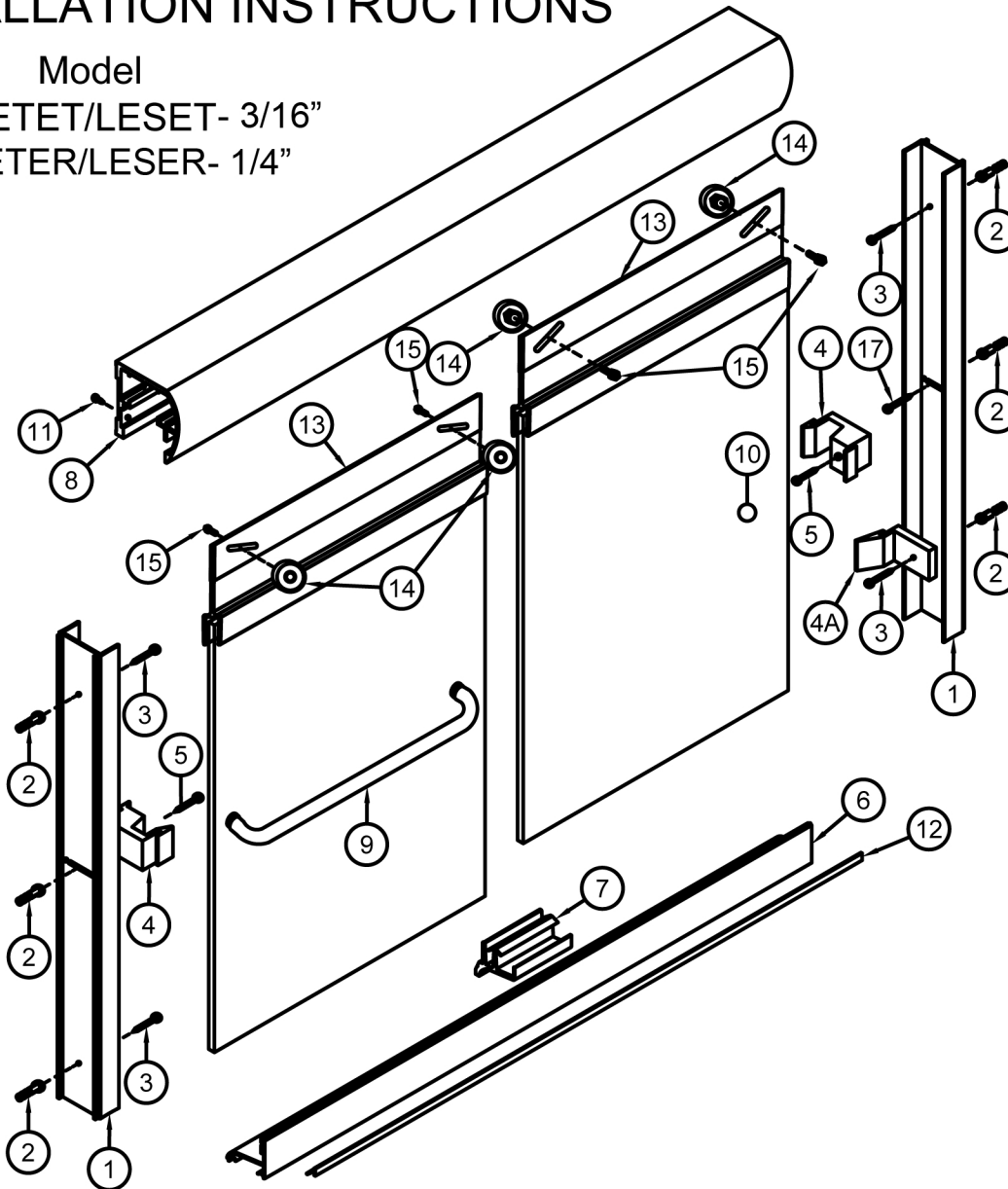

When ordering replacement parts, please provide the following information:

1. Part Number
2. Part Name
3. Model Number
4. Specify design (if any)

To install your Shower Enclosure you will need the following:

- Level
- 1/8" and 9/64" Drill Bits
- (Tile) 3/16" Masonry Bit
- Phillips Screwdriver
- Sealant
- Hack Saw

#	Description	Qty	Part #	Picture
1	Wall Jamb	2	ZTE-1203	
2	Screw Anchor	6	ZV-935	
3	#8X1 1/4 Pan Head Screw	6		
4	Bumper	2	ZV-924	
4A	Bottom Bumper	1	ZV-926	
5	#6/32X1/2 Machine Screw	2		
6	Curb	1	ZTE-1222	
7	Center Guide	1	ZV920-3	
8	Header	1	ZTE-6201	
Glass with 1/2" Holes				
9	Towel Bar	1	ASD24T	
10	Pull Handle	1	ASD1	
Glass with 7/8" Holes				
9	Towel Bar	1	ASD24R	
10	Pull Handle	1	ASD1R	
11	#6X3/8 Pan Head Screw	2		
12	Curb Vinyl	1	ZV-918	
13	Full Top Rail 3/16"	2	ZTE-3208	
	Full Top Rail 1/4"	2	ZTE-3214	
14	Roller Wheel	4	ZA-99	
15	#8/32x3/8 CH	4		

Arizona Corporate Office
2801 W. Indian School Rd
Phoenix, AZ 85017
800-255-1901 PH
602-447-8208 FAX

Florida
8100-1 Westside Industrial Dr
Jacksonville, FL 32219
855-695-8899 PH
904-786-9025 FAX

Illinois
2601 Bond St #1
University Park, IL 60484
800-861-6120 PH
708-235-0729 FAX

Oregon
2057 Lars Way
Medford, OR 97501
866-773-7905 PH
541-773-7909 FAX

Colorado
3871 Revere Street
Denver, CO 80239
866-574-1766 PH
303-574-1775 FAX

Utah
2594 S. 3600 West Suite A
West Valley City, UT 84119
877-402-5007 PH
801-972-3111 FAX

ARIZONA SHOWER DOOR

Tools you will need for this install

- ✓ Exploded View drawing of shower door
- ✓ 3/16" Masonry drill bit (use 9/64" drill bit for fiberglass)
- ✓ 1/8" drill bit
- ✓ Drill
- ✓ 4' Level
- ✓ Saw (Electric Chop saw or Hacksaw)
- ✓ Side cutting pliers
- ✓ #2 Phillips drill bit
- ✓ #2 Phillips screwdriver
- ✓ Tape Measure
- ✓ Pencil or Pen
- ✓ Caulking Gun
- ✓ 1-Tube of 100% Clear Silicone (no latex!)
- ✓ Vacuum Cleaner or Brush for clean up
- ✓ Glass Cleaner and Paper Towels
- ✓ Rubber Mallet
- ✓ File

INSTALLATION INSTRUCTIONS
FOR

MODEL LETET/LESET

Note: These instructions will refer to the item #'s in the Exploded View drawing. For example, #1, #2, #3 etc...
Please read through **all** of the instructions to get an over-view **before** you install the door.

1) Find the centerline of where the unit will be installed. This will usually be the center of the ledge of the bath tub or the curb of the shower pan. Place a centerline mark at each end of the tub ledge or curb where it meets the wall. This mark will also represent the center of the ZTE1203 wall jamb (item #1 in exploded view). Place the wall jamb against the wall and on top of the ledge or curb aligning centerline marks

(A). If your shower is fiberglass you might have to file the backside corner of the ZTE1203 to a radius so the jamb sits as flush as possible on the ledge or curb. Use a level to position the jamb plumb, then mark the installation holes

with a pen or pencil **(B)**. Repeat this procedure for the other jamb. Now drill the 6 holes with a 3/16" masonry bit (9/64" for fiberglass, & without anchors). Then insert the 6)-ZV935 screw anchors (#9) in the holes. Fasten the ZTE1203 wall jambs in place using the #8X1-1/4 Phillips Pan Head screws provided (#3) **(C)**.

Important Note: The ZV926 Bottom Bumper (#4A) needs to be installed with the bottom screw on the jamb, on the showerhead side of the unit, with the angled side of the bumper going to the inside of the shower **(D)**. Refer to the exploded view. Attach

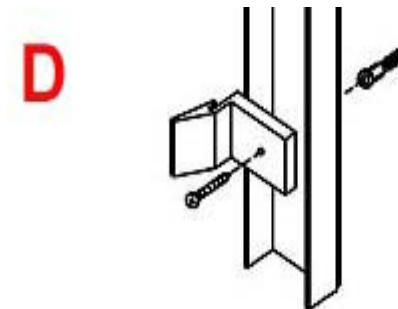
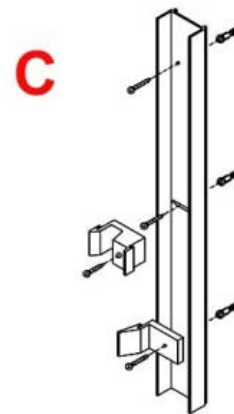
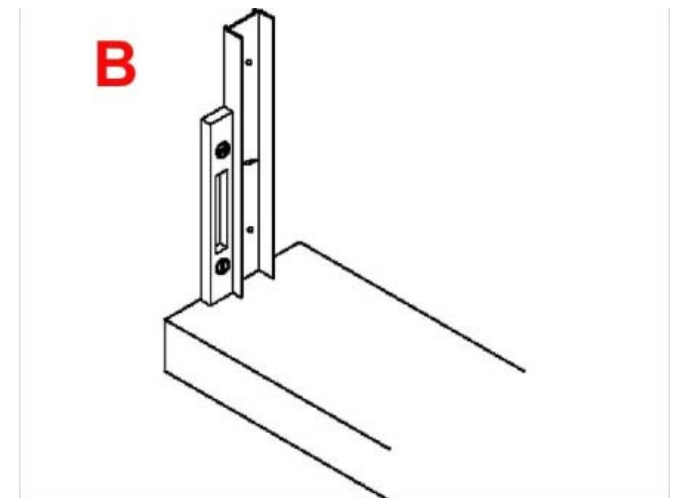
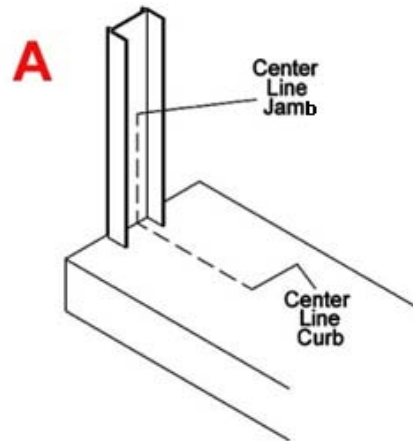

the ZV924 Bumpers (#4) using the 2-#6/32X1/2 Machine screws (#5) keeping in mind that the inside panel will be on the showerhead side of the shower.

2) Measure the distance between the inside of the wall jambs (just above the tub ledge or curb). Measure tight and deduct 1/16" to 1/8" to get the cut size of the ZTE1222 Curb (#6) **(E)**. Cut to size. Apply silicone where wall jambs meet tub or curb. Then run a bead along the underneath of the ZTE1222 Curb **(F)**. Slide the curb down between the wall jambs and onto the tub/shower. Make sure the curb is solid and doesn't rock back and forth. If it is not solid secure it with two of the #6X3/8" Pan Head Screws (#13) provided by drilling with a 1/8" drill bit through the outside leg of the wall jamb at the bottom, into the face of the curb and inserting the screws **(G)**.

3) Measure the distance from wall to wall across the top of the jambs. Cut the ZTE6201 Header (#8) to that dimension minus -1/16". Slide the header down over the top of the wall jambs. The header does not need to be secured with screws **(H)**.

4) Setting of the glass. The inside panel will be set first. This will be done as you stand on the **outside** of the shower. Grip one of the panels on each side so that the rollers are facing **away** from you. Lift the panel so that the bottom edge of the glass clears the top of the ZTE1222 Curb as you lower it into the shower. **Do not set the glass down on its edge. Be very careful to not hit the edge on anything.** Continue lowering the panel down

E

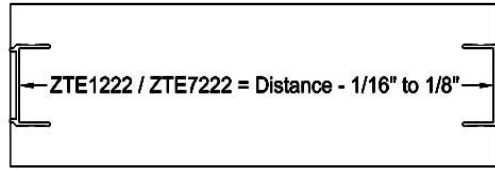

F

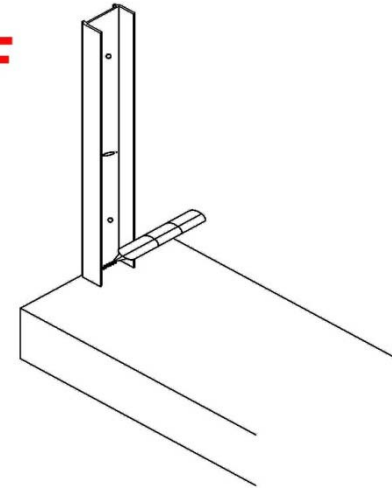

F2

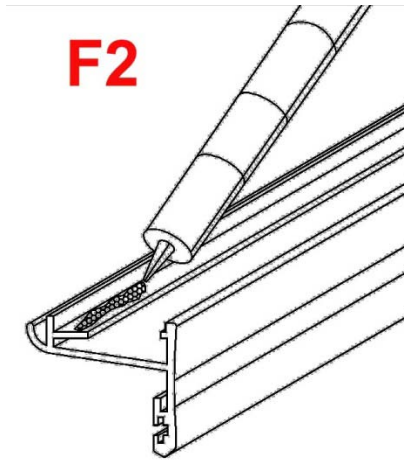

G

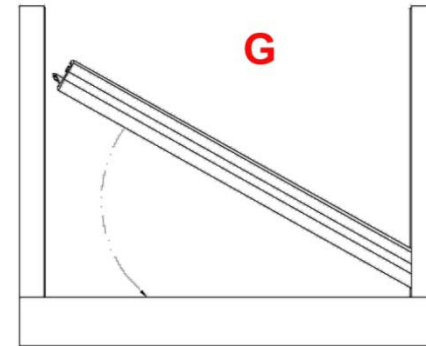

G2

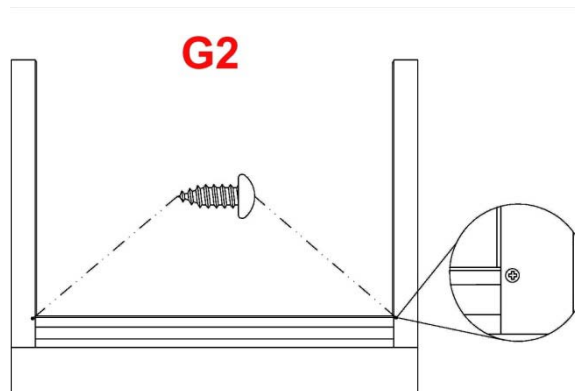

H

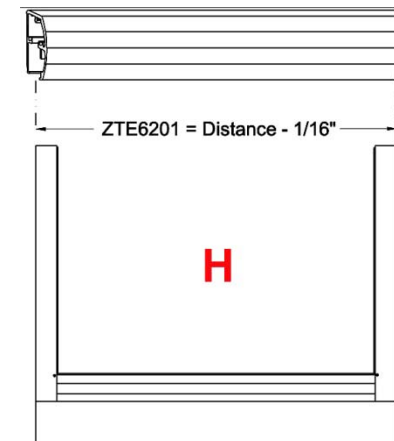

inside roller track of the header. Lift up glass then slowly lower the rollers into the inside roller track and let the panel hang in its vertical position. The outside panel will be installed the same way. Make sure the rollers are facing **to-ward** you. A helper would be valuable at this point to hold the inside panel on an angle toward the inside so that the outside panel can be lowered and positioned to be installed into the outside roller track. The inside panel will be positioned at the showerhead side of the shower while the outside panel will be positioned opposite the showerhead. This is to ensure that no water escapes through the overlap **(I)**.

5) Adjust Rollers. (J) The roller wheels are mounted to angled slots in the top rail on the glass. Lowering the roller in the slot raises the glass. Raising the roller in the slot lowers the glass. Start out with the rollers mounted in the middle of the angled slot. If the panel needs to be adjusted you can remove the panel, adjust with a screwdriver then, reset the panel. This might be done one or two times until you achieve proper alignment. The end result should be that the vertical edge of the panel is parallel to your wall jamb to achieve maximum coverage.

6) Attach the ZV920 Center Guide (#7). Slide both panels to one end. The front lip of the guide slips into the slot on the inside of the

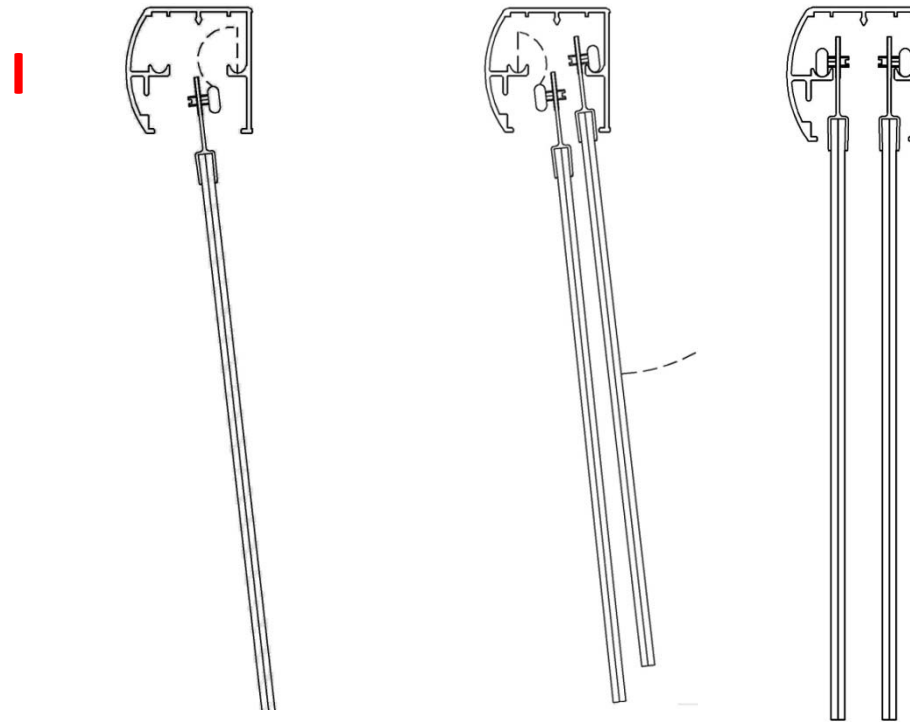

J

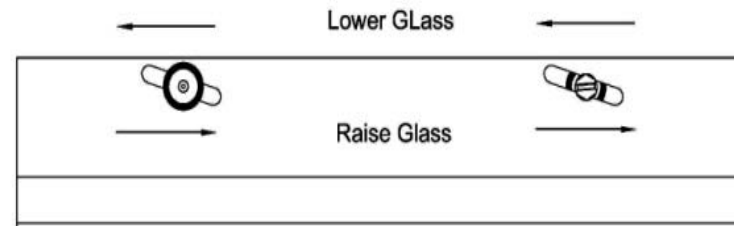

front edge of the ZTE1222 Curb. Position the guide just to the side of the panels, slip the front lip in, then snap the guide down over the inside of the curb. Slide the guide over carefully. When the doors are in a closed position the center guide should be centered in the overlap of the glass **(K)**. For added security you can attach the guide after it is snapped in place by drilling with a 1/8" drill bit through the snap in leg into the curb (from the inside of the shower) then running a #6X3/8 screw into the hole.

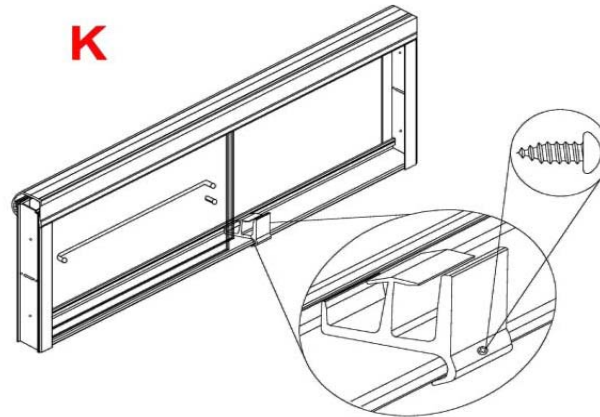

7) *please see attached before proceeding Attach the ASD-1 (#10) Knob Pull **(L)** by inserting the threaded bolt with grommet through the hole. This will be the inside panel with one hole which will be on the showerhead side of the opening. The knob should be on the inside. Also make sure the plastic washers provided are on each side of the glass. Use the small Allen wrench provided to insert into the small hole on the bolt head. Turn and tighten the bolt until the knob is secure. Over tightening can cause the glass to blow up.

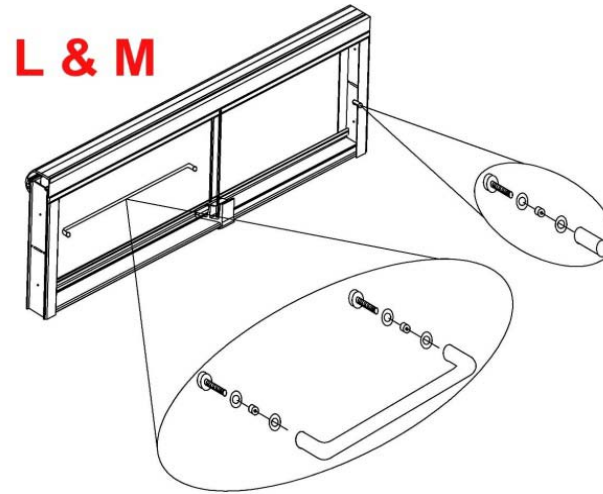

8) Attach the towel bar **(M)** on the outside panel with two holes using the same method as the knob in step 7.

9) Run a bead of silicone on the gap between the metal and the shower surface inside and out. Fill all joints and gaps where metal meets metal and fill with a fine bead **(N)**.

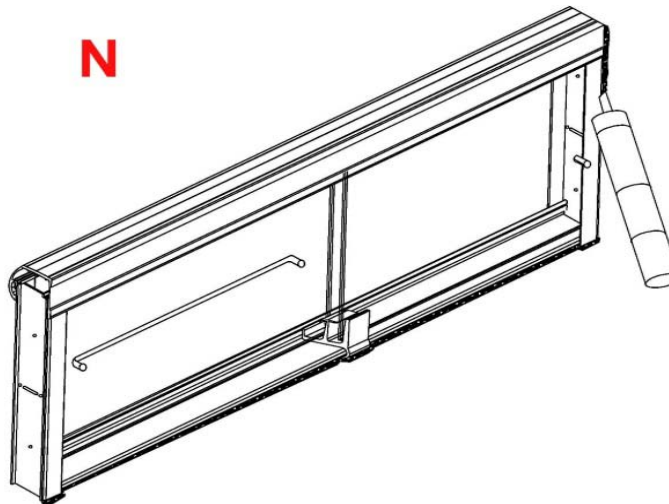

* Towel bar and Pull Handle Addendum

Due to design changes in the **LETET, LESET, ETE, and ESE** Series of bypass shower enclosures. There are now two separate types of pull handle and towel bars. The (ASD1) pull handle and the (ASD#T) towel bar are designed for glass with 1/2" holes. While the (ASD1R) pull handle and (ASD#R) towel bar are designed for glass with 7/8" holes. While ordering replacement parts please specify hole dimension.(1/2" or 7/8").

*** # = centerline width of the towel bar (ex: 18", 24", and 27") ***