

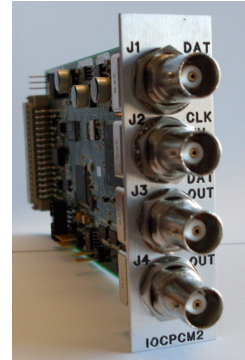

IOCPCM2 PCM GENERATOR MODULE



FEATURES

- PCM data acquisition output module (encoder)
- IRIG 106 Class I and II compatible output
- TTL DATA and 0° CLK
- Programmable features:
 - ◊ Output rate: 1 Kbps to 20 Mbps
 - ◊ Output codes: NRZ-L, BiØ-L, RNRZL-15
 - ◊ Frame sync pattern: First Two words
 - ◊ Word length: 8 to 16 bits
 - ◊ Frame length: Up to 1024 words/frame
 - ◊ Sub-frame generator
- Supports expansion to second chassis

OVERVIEW

The IOCPCM2 module is the data and clock generation portion of a telemetry encoder system. This module is responsible for setting the output data rate, code, frame sync pattern, bit length, word length, and sub-frame . It receives the remaining data from up to 13 data acquisition modules installed in the AL2873 chassis. This module supports an expansion option that extends the PCM stream to a second chassis and 13 additional acquisition modules.

Two setup screens are provided that allows the user to configure the module. The PCM module defines the PCM frame and sub-frame while the individual data acquisition modules fill the PCM format per their individual settings. Any word location not allocated by a data acquisition module is filled with zeros. An additional 13 data acquisition modules can be configured in an expansion chassis and included PCM data stream. The IOCPCM2 Data and Clock inputs are setup to receive data and clock from an expansion chassis IOCPCM2 module.

Control of the IOCPCM2 is accomplished via the front panel keypad and 3" x 2" LCD or Ethernet and the APEX software package. When configured the current setup is retained in non-volatile memory and is automatically restored on power up with a recovery time of less than 20 seconds.

APPLICATION NOTES

The IOCCPM2 is the data generation portion of a data acquisition system. This module is used in conjunction with the suite of data acquisition boards that plug into the AL2873 chassis. A fully configured system is capable of acquiring analog, digital, PC Com ports, Audio, and IRIG timing. Several typical signals are receiver AGC levels, Bit Sync and Frame Sync lock status, station timing, station voice, GPS RS-232 outputs, and serial data streams from antenna position encoders.

System block diagrams are shown below.

Figure 1: Fully Populated Chassis

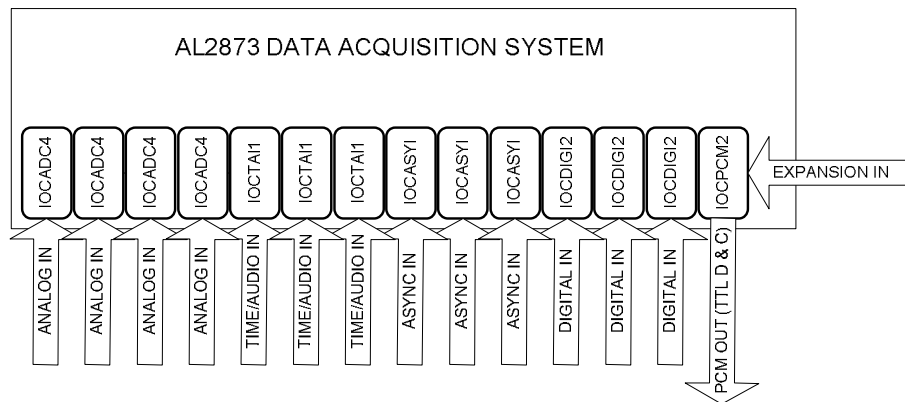
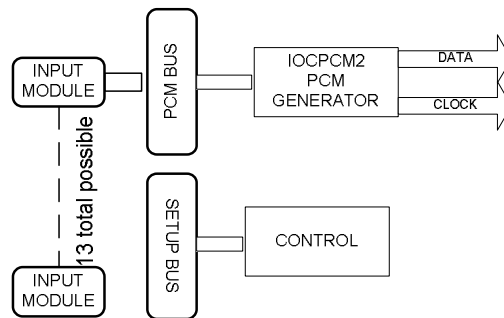

Figure 2: Functional Block Diagram



SPECIFICATIONS

GENERAL

- Single slot module (3" x 6" x 0.9")
- One module per chassis

INPUT (expansion chassis use only)

- TTL data and 0° clock
- Termination: 51Ω and 75Ω jumper selectable
- Codes: NRZ-L

OUTPUT

- TTL Data and 0° Clock / BNC connectors
- 51Ω / 75Ω driver
- Codes: NRZ-L, BiØ-L, RNRZ-15

ENVIRONMENTAL

- Operating temperature: 0° to 50° C
- Relative humidity: 15% to 95%; non-condensing
- Altitude: Sea level to 10,000 feet

POWER

- +5V input from AL2873 chassis backplane

MEAN TIME BETWEEN FAILURES

- ~ 100,000 hours