



**WATERFALL AUDIO**  
SOUND DESIGNERS



MADE IN FRANCE



DISCOVER OUR COLLECTION...



04	FLOORSTANDING GLASS SPEAKERS
10	ON WALL & ON SHELF COMPACT SPEAKERS
16	OPTIONAL ACCESSORIES FOR COMPACT SPEAKERS
18	INTEGRABLE IN WALL SPEAKERS
22	INTEGRABLE ACTIVE SUBWOOFER
26	CLASSIC ACTIVE SUBWOOFERS
31	HOME CINEMA LIVING ROOM
35	HOME CINEMA DEDICATED ROOM
42	DSP AMPLIFIER RS700 SPECIAL EDITION
46	EXCLUSIVE TECHNOLOGIES JESTREAM & HEATSTREAM
50	CUSTOM DESIGN SPEAKER LAGOON YACHTS

# FLOORSTANDING GLASS SPEAKERS

Timeless and unique, a distinctive concept,  
an experience beyond comparison.



Iguasçu XT

Pure refinement with its harmonious proportions, Iguasçu XT, is the most compact of our floorstanding speakers delivering harmonious and pure sound.



Victoria XT

Emblematic of our range, Victoria XT is the 4th generation of a speaker designed in the wake of the new millennium. Pure and elegant lines, breathtaking sound in every style of music.

For the past 25 years, Waterfall has transformed a loudspeaker into a rare work of art in the industry. Our glass speakers blend in your interior and bring this special distinctive touch. Their transparency allows them to fit into any style of decor with classic elegance. We use safety glass for our speakers.



# FLOORSTANDING GLASS SPEAKERS

Discover our new Niagara XT series.



### Niagara XT1

The Niagara XT1 delivers exceptional sound reproduction. It offers in a more compact format (1m height) all the assets of its big sister XT2, including a fabulous horn crafted from solid wood.

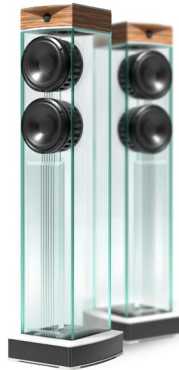

### Niagara XT2

The Niagara XT2 integrates all the codes of luxury from the original version (created in 2007), adding an exclusive touch with its solid wood horn that makes each pair absolutely unique.



### Niagara XT3

The Niagara XT3 represents the culmination of more than 25 years of experience in the fields of very high materials and acoustics technologies. Its glass horn remains an object without equivalent.

The highly original use of glass for our speakers has led us to rethink the various techniques used for conventional loudspeaker in their shapes and functions. Our constant quest for performance and complete integration has driven us to develop innovating technologies and state of the art manufacturing processes.



## TECHNICAL DETAILS

IGUASCU XT

TYPE	2 way - 3 drivers
RECOMMENDED AMPLIFIER (WITHOUT CLIPPING)*	40 - 150 Watts
PEAK POWER	300 Watts
IMPEDANCE (AVERAGE/MINI)	8 / 4 Ohms
EFFICIENCY (2.83V/1M)	88 dB
FREQUENCY RESPONSE (+/- 3 dB)	50 Hz - 28 kHz
ULTRA LOW FREQUENCY DRIVER	1 x 210 mm / 8» Atohm UFR210
BASS / MIDRANGE DRIVER	1 x 150 mm / 6» Atohm LD150
TWEETER	1 x 20 mm / 0.75" Atohm SD20
DIMENSIONS (width x depth x height in mm) (approx. inches)	250 x 250 x 870 / 9.84» x 9.84» x 34.25»
WEIGHT Kg (approx. lbs.)	14 kg / 30.8 lbs

VICTORIA XT

TYPE	2 ½ way - 4 drivers
RECOMMENDED AMPLIFIER (WITHOUT CLIPPING)*	40 -200 Watts
PEAK POWER	400 Watts
IMPEDANCE (AVERAGE/MINI)	8 / 4 ohms
EFFICIENCY (2.83V/1M)	89 dB
FREQUENCY RESPONSE (+/- 3 dB)	42 Hz - 28 kHz
ULTRA LOW FREQUENCY DRIVER	1 x 210 mm / 8" Atohm UFR210
BASS / MIDRANGE DRIVER	2 x 150 mm / 6" Atohm LD150
TWEETER	1 x 20 mm / 0.75" Atohm SD20
DIMENSIONS (width x depth x height in mm) (approx. inches)	250 x 250 x 1010 / 9.84" x 9.84" x 39.76"
WEIGHT Kg (approx. lbs.)	17 kg / 37.4 lbs

JETSTREAM TECHNOLOGY

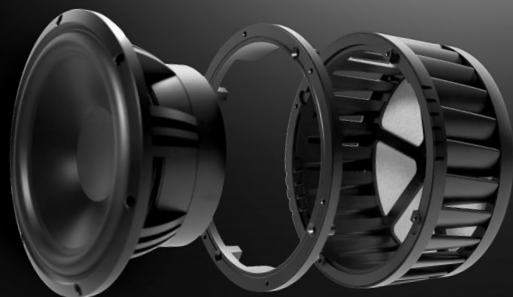

\* Power without clipping; the use of an amplifier beyond its limits provokes clipping of the signal which might lead to destruction of the speaker (burnt voice coils). These damages are not covered by warranty.

## TECHNICAL DETAILS

NIAGARA XT1

TYPE	2 ½ way – 4 drivers
RECOMMENDED AMPLIFIER (WITHOUT CLIPPING)*	40 - 200 Watts
PEAK POWER	400 Watts
IMPEDANCE (AVERAGE/MINI)	8 / 4 ohms
EFFICIENCY (2.83V/1M)	89 dB
FREQUENCY RESPONSE (+/- 3dB)	42 Hz - 28 kHz
ULTRA LOW FREQUENCY DRIVER	1 x 210 mm, Atohm UFR210
BASS / MIDRANGE DRIVER	2 x 150 mm, Atohm LD150
TWEETER	1 x 20 mm, Atohm SD20X + wood horn
DIMENSIONS (width x depth x height in mm)	250,00 x 280,65 x 991,20
WEIGHT Kg (approx. lbs.)	20 kg

NIAGARA XT2

TYPE	2 ½ way – 4 drivers
RECOMMENDED AMPLIFIER (WITHOUT CLIPPING)*	40 -250 Watts
PEAK POWER	500 Watts
IMPEDANCE (AVERAGE/MINI)	8 / 4 ohms
EFFICIENCY (2.83V/1M)	90 dB
FREQUENCY RESPONSE (+/- 3dB)	35 Hz - 28 kHz
ULTRA LOW FREQUENCY DRIVER	1 x 210 mm, Atohm UFR210
BASS / MIDRANGE DRIVER	2 x 180 mm, Atohm LD180
TWEETER	1 x 20 mm, Atohm SD20X + wood horn
DIMENSIONS (width x depth x height in mm)	300,00 x 346,25 x 1169,20
WEIGHT Kg (approx. lbs.)	40 kg

NIAGARA XT3

TYPE	2 ½ way – 4 drivers
RECOMMENDED AMPLIFIER (WITHOUT CLIPPING)*	40 -250 Watts
PEAK POWER	500 Watts
IMPEDANCE (AVERAGE/MINI)	8 / 4 ohms
EFFICIENCY (2.83V/1M)	90 dB
FREQUENCY RESPONSE (+/- 3dB)	35 Hz - 28 kHz
ULTRA LOW FREQUENCY DRIVER	1 x 210 mm, Atohm UFR210
BASS / MIDRANGE DRIVER	2 x 180 mm, Atohm LD180
TWEETER	1 x 20 mm, Atohm SD20X + glass horn
DIMENSIONS (width x depth x height in mm)	300,00 x 346,25 x 1169,20
WEIGHT Kg (approx. lbs.)	44 kg

\* Power without clipping: the use of an amplifier beyond its limits provokes clipping of the signal which might lead to destruction of the speaker (burnt voice coils). These damages are not covered by warranty.

# ON WALL & ON SHELF COMPACT SPEAKERS

Luxury and minimalism. Compact and powerful.



Sério

Immerse yourself into your music with this Serio mini satellite.

Glass and aluminium in black or white with matching grill, wall bracket included.



Hurricane Evo

Compact and stylish, with harmonious shapes, Hurricane Evo is a totally versatile speaker.

Glass and aluminium in black or white with matching grill, wall bracket included.



Elora Evo L/R

Elegant and classy, Elora Evo LR is a real "must have" and one of a kind on the market.

Glass and aluminium, wall bracket included. Black or white optional grills available, compatible with Vesa 75 supports.



Elora Evo Center

To be used as a center speaker in our home cinema applications.

Glass and aluminium, wall bracket included. Black or white optional grills available, compatible with Vesa 75 supports.

## INNOVATIONS CONDENSED

These « on-wall » speakers deliver a remarkable pure sound with no comparison, in respect of their small thin size, thanks to the use of our patented Heatstream technology.

When coupled with one of our subwoofers you will be dazzled by their stereo or home cinema performance.







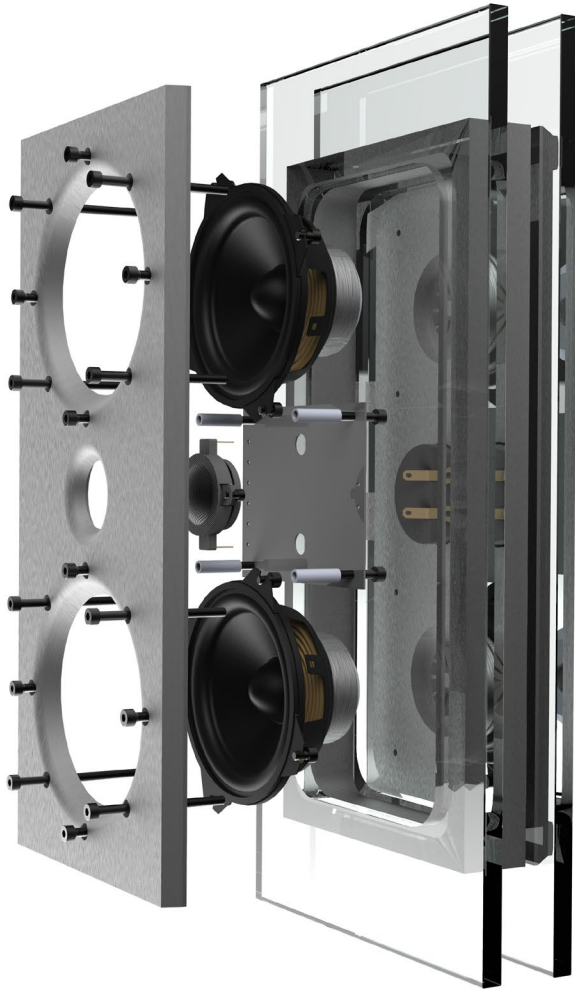

*Elora Evo Technical View*

## TECHNICAL DETAILS

SERIO

TYPE	Full range - 1 driver, closed
RECOMMENDED AMPLIFIER *	30 - 80 Watts
PEAK POWER	150 Watts
IMPEDANCE (AVERAGE/MINI)	8 / 4 Ohms
EFFICIENCY (2.83V/1M)	87 dB
FREQUENCY RESPONSE (+/- 3 dB)	180 Hz - 20 kHz
FULL RANGE DRIVER	1 x 80 mm / 3" Atohm LD80
DIMENSIONS (width x depth x height in mm) (approx. inches)	125 x 80 x 125 / 4.92" x 3.15" x 4.92"
WEIGHT Kg / approx. lbs	1 kg / 2.2 lbs

HURRICANE EVO

TYPE	2 way - 2 drivers, closed
RECOMMENDED AMPLIFIER *	50 - 150 Watts
PEAK POWER	300 Watts
IMPEDANCE (AVERAGE/MINI)	8 / 4 Ohms
EFFICIENCY (2.83V/1M)	87 dB
FREQUENCY RESPONSE (+/- 3 dB)	120 Hz - 28 kHz
BASS / MIDRANGE DRIVER	1 x 100 mm / 4" Atohm LD100
TWEETER	1 x 20 mm / 0.75" Atohm SD20
DIMENSIONS (width x depth x height in mm) (approx. inches)	185 x 76.5 x 277 / 7.28" x 3" x 10.91"
WEIGHT Kg / approx. lbs	2.0 kg / 4.4 lbs

ELORA EVO CENTER & L/R

TYPE	2 ½ way - 3 drivers, closed
RECOMMENDED AMPLIFIER *	30 - 250 Watts
PEAK POWER	400 Watts
IMPEDANCE (AVERAGE/MINI)	8 / 4 Ohms
EFFICIENCY (2.83V/1M)	90 dB
FREQUENCY RESPONSE (+/- 3 dB)	120 Hz - 28 kHz
BASS / MIDRANGE DRIVER	2 x 100 mm / 4" Atohm LD100
TWEETER	1 x 20 mm / 0.75" Atohm SD20
DIMENSIONS (width x depth x height in mm) (approx. inches)	190 x 80 x 420 / 7.48" x 3.15" x 16.54"
WEIGHT Kg / approx. lbs	6 kg / 13.2 lbs

\* Important note : the use of an amplifier beyond its limits, provokes clipping of the signal which might lead to destruction of the speaker (burnt voices coils), these damages are not covered by our warranty.

## OPTIONAL ACCESSORIES FOR COMPACT SPEAKERS



### Elora Evo grill

Magnetic  
Black or white

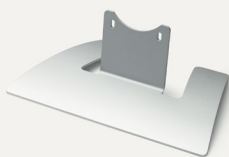

### Elora Evo shelf stand

Aluminium  
Compatible L/R and Center



### Hurricane Evo shelf stand

Metal  
Black or white



### Hurricane Evo wall bracket

For horizontal position



### Audio cable

100m roll, 2 mm<sup>2</sup>



# INTEGRABLE IN WALL SPEAKERS

High-End integration.  
A versatile 3 in 1 solution to fit into your interior.

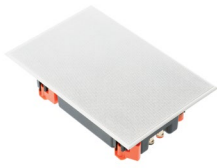

**Hurricane In Wall  
Classic**

A classic flush mount white paintable grill featuring our Hurricane Evo speaker nested in a high tech back box to ensure perfect sound reproduction.



**Hurricane In Wall  
Black Glass**

A unique version integrating an elegant black glass finish, featuring our Hurricane Evo speaker nested in a high tech back box to ensure perfect sound reproduction.



**Hurricane In Wall  
White Glass**

A unique version integrating an elegant white glass finish, featuring our Hurricane Evo speaker nested in a high tech back box to ensure perfect sound reproduction.

## DELIVERING TRUE WATERFALL PURE SOUND

Unlike many inwall speakers which are open at the back, our speakers are delivered with a back box which guarantees optimal conditions for the driver. Designed around a low depth structure (73mm) incorporating our high tech back box made up of high density fiber ABS chassis, a true damping treatment with a special material, as well as an asphalt plate to provide complete inertia.



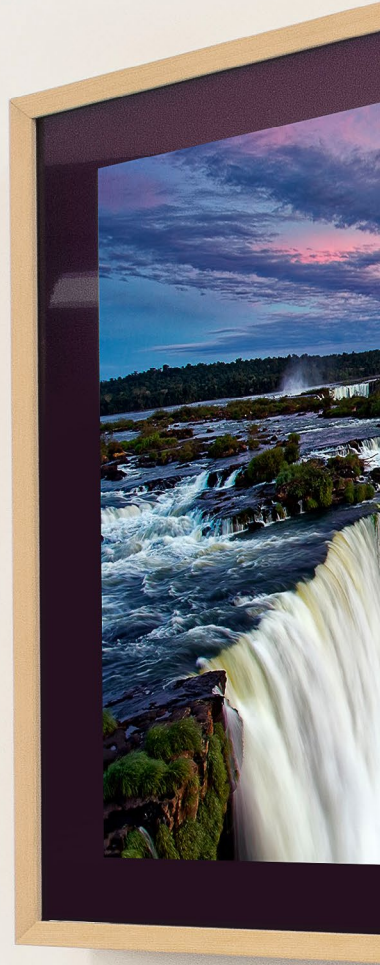

## TECHNICAL DETAILS

### HURRICANE IN WALL CLASSIC

TYPE	2 way - 2 drivers, closed
RECOMMENDED AMPLIFIER *	50 - 150 Watts
PEAK POWER	300 Watts
IMPEDANCE (AVERAGE/MINI)	8 / 4 Ohms
EFFICIENCY (2.83V/1M)	87 dB
FREQUENCY RESPONSE (+/- 3 dB)	90 Hz - 28 kHz
BASS / MIDRANGE DRIVER	1 x 100 mm / 4" Atohm LD100
TWEETER	1 x 20 mm / 0.75" Atohm SD20
DIMENSIONS (width x depth x height in mm) (approx. inches)	178 x 77 x 274 / 7" x 2.03" x 10.79"
WEIGHT Kg / approx lbs	2,5 kg / 5,5 lbs

### HURRICANE IN WALL BLACK GLASS

TYPE	2 way - 2 drivers, closed
RECOMMENDED AMPLIFIER *	50 - 150 Watts
PEAK POWER	300 Watts
IMPEDANCE (AVERAGE/MINI)	8 / 4 Ohms
EFFICIENCY (2.83V/1M)	87 dB
FREQUENCY RESPONSE (+/- 3 dB)	90 Hz - 28 kHz
BASS / MIDRANGE DRIVER	1 x 100 mm / 4" Atohm LD100
TWEETER	1 x 20 mm / 0.75" Atohm SD20
DIMENSIONS (width x depth x height in mm) (approx. inches)	185 x 101 x 277 / 7" x 4" x 10.79"
WEIGHT Kg / Approx lbs	3,0 kg / 6,6 lbs

### HURRICANE IN WALL WHITE GLASS

TYPE	2 way - 2 drivers, closed
RECOMMENDED AMPLIFIER *	50 - 150 Watts
PEAK POWER	300 Watts
IMPEDANCE (AVERAGE/MINI)	8 / 4 Ohms
EFFICIENCY (2.83V/1M)	87 dB
FREQUENCY RESPONSE (+/- 3 dB)	90 Hz - 28 kHz
BASS / MIDRANGE DRIVER	1 x 100 mm / 4" Atohm LD100
TWEETER	1 x 20 mm / 0.75" Atohm SD20
DIMENSIONS (width x depth x height in mm) (approx. inches)	185 x 101 x 277 / 7" x 4" x 10.79"
WEIGHT Kg / approx. lbs	3,0 kg / 6,6 lbs

\* Important note : the use of an amplifier beyond its limits, provokes clipping of the signal which might lead to destruction of the speaker (burnt voices coils), these damages are not covered by our warranty.

# INTEGRABLE ACTIVE SUBWOOFER

## FLEX200

A flexible subwoofer, dedicated to integration.  
A new innovating and design concept featuring multiple applications.  
A designer friendly looking front panel which can be painted  
to your desired colour, hiding all equipment.



**FLEX200**

Optimal performances for SUB FLEX200, driver and bass reflex radiating simultaneously into the room for natural and thundering bass response.

Whether you have a stereo or a home cinema configuration, bringing a subwoofer to your system will add low frequencies and increase the feeling of action and drama in your films and your favourite music.

Subwoofer FLEX200 will add low-end punch, making a definite difference in dynamics.



# INTEGRATION POSSIBILITIES

Minimum thickness required  
100mm

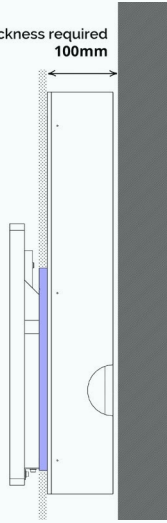

-  Adjustable thickness frame  
12, 19, 24, 31 et 38 mm
-  Standard partition  
BA13, 2x BA13, BA13 + BA18, 2x BA18
-  Main wall

## IN WALL INTEGRATION (DRY WALL)

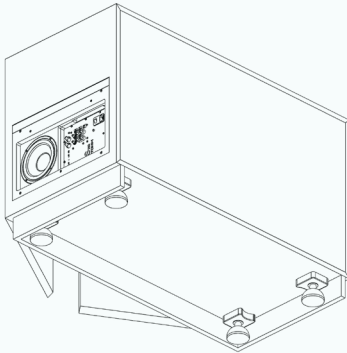

INTEGRATION INTO CUSTOM  
MADE FURNITURE

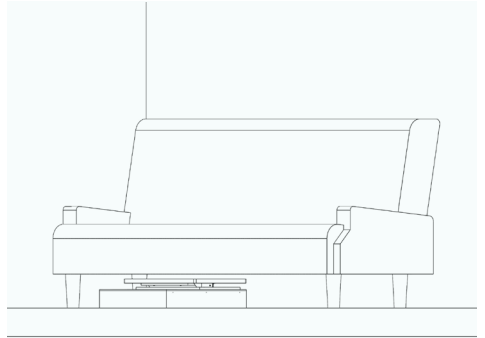

UNDER FURNITURE INTEGRATION  
(SOFA, BED...)



## TECHNICAL DETAILS

SUBWOOFER FLEX200

TYPE	Active / bass reflex
INTEGRATED AMPLIFIER	200 Watts / X-GUARD Technology*
PEAK POWER	250 Watts
FREQUENCY RESPONSE (+/- 3 dB)	40 Hz - 150 Hz
PHASE CONTROL	Switch 0 / 180°
CROSSOVER FREQUENCIES	Variable 40 Hz to 150 Hz or LFE mode
BASS DRIVER	1 x 180mm / 7" ATOHM D180
DIMENSIONS (width x depth x height in mm)	500 x (Variable from 99 to 180) x 599
(approx. inches)	19,69 x (Variable from 3,89 to 7,09) x 23,58
WEIGHT Kg / approx. lbs	22,5 kg / 55,12 Lbs

\* X-GUARD TECHNOLOGY guarantees the perfect match between the amplifier and the driver. It preserves phase integrity of the signal and maximal dynamic for pure deep and natural low frequencies.

## ACTIVE SUBWOOFERS

Pure, deep and natural bass are the foundations of your music and films. Our subwoofers deliver dense and striking low frequencies with rare musical quality and extraordinary impact.



**HFM-200X**

With its 18 cm driver this compact and powerful subwoofer reaches its optimal performances with Serio or Hurricane speakers in rooms under 30m<sup>2</sup>.

Available in black or white satin finish.



**HF2-250X**

With its 23 cm driver, elegant proportions and moderate size, this subwoofer is explosive, a wise choice to create compact hifi systems or home cinema with amazing sound quality.

Available in black or white satin finish.



**HF3-500X**

With its 2 x 23 cm drivers, the HF3-500X is particularly comfortable in large rooms. Very musical, it delivers exceptional infra low frequencies. No soundtrack will resist it.

Available in black or white satin finish.

Low frequency reproduction without distortion at high volume is a difficult task ! In such a compact space it is a real challenge, but with ATOHM drivers capacities and optimized amplification we invite you to discover low frequency in a different way.





## TECHNICAL DETAILS

HFM-200X

TYPE	Active - bass reflex
INTEGRATED AMPLIFIER	200 Watts / X-GUARD TECHNOLOGY *
PEAK POWER	250 Watts
FREQUENCY RESPONSE (+/- 3 dB)	40 Hz - 150 Hz
PHASE CONTROL	Switch 0° / 180°
CROSSOVER FREQUENCIES	Variable 40 Hz to 150 Hz or LFE mode
BASS DRIVER	1 x 180 mm / 7" ATOHM D180
DIMENSIONS (width x depth x height in mm) (approx. inches)	220 x 350 x 320 / 8.66" x 13.78" x 12.60"
WEIGHT Kg / approx. lbs	12 kg / 26.4 lbs

HF2-250X

TYPE	Active - bass reflex
INTEGRATED AMPLIFIER	250 Watts / X-GUARD TECHNOLOGY *
PEAK POWER	300 Watts
FREQUENCY RESPONSE (+/- 3 dB)	33 Hz - 150 Hz
PHASE CONTROL	Switch 0° / 180°
CROSSOVER FREQUENCIES	Variable 40 Hz to 150 Hz or LFE mode
BASS DRIVER	1 x 230 mm / 9" ATOHM LD230
DIMENSIONS (width x depth x height in mm) (approx. inches)	250 x 430 x 410 / 9.84" x 16.93" x 16.14"
WEIGHT Kg / approx. lbs	20 kg / 44 lbs

HF3-500X

TYPE	Active - bass reflex
INTEGRATED AMPLIFIER	500 Watts / X-GUARD TECHNOLOGY *
PEAK POWER	650 Watts
FREQUENCY RESPONSE (+/- 3 dB)	29 Hz - 150 Hz
PHASE CONTROL	Switch 0° / 180°
CROSSOVER FREQUENCIES	Variable 40 Hz to 150 Hz or LFE mode
BASS DRIVER	2 X 230 mm / 9" ATOHM LD230
DIMENSIONS (width x depth x height in mm) (approx. inches)	290 x 490 x 520 / 11.42" x 19.29" x 20.47"
WEIGHT Kg / approx. lbs	30 kg / 66 lbs

\* X-GUARD TECHNOLOGY guarantees the perfect match between the amplifier and the driver. It preserves phase integrity of the signal and maximal dynamic for pure deep and natural low frequencies.



# HOME CINEMA LIVING ROOM

—

## LIFESTYLE CINEMA IN YOUR LIVING ROOM

Multichannel sound brings a third dimension to the cinema experience. Discover five home cinema packs to fit your rooms and discover your music and films in a new way.

Our speakers are all matched sonically and our various packs are determined in function of your interior, to bring you a real cinematic and immersive surround sound exposure.

# HOME CINEMA LIVING ROOM



**Pack 1**

Minimalist, discreet and efficient, perfect for a small living room or bedroom.



**Pack 2**

Fill up your room with sound, not your floor space, also for a small living room or bedroom.



**Pack 3**

Compact with outstanding musical sound performance.



**Pack 4**

Luxury cinema solution for unequalled performance with style.



**Pack 5**

Ultimate solution : a new dimension and look for luxury home cinema or for pure hifi.

These packages offer depth, add light and shade, and spatialize everything seen on your cinema screen. Our speakers are pure and precise and when associated to our impactful subwoofers, you will find yourself submerged by new fantastic feelings. Never has home cinema been so captivating. Depending of your room size and other integration restraints, our diverse range of packs will bring the right solution to your needs.





# HOME CINEMA DEDICATED ROOM

—

## PRO CUSTOM SERIES

The « Professional Custom Series » range was initiated following the request from many customers to extend the Waterfall Experience in sound well into the private residential cinema rooms. This new "In wall" range proposes the Waterfall sound signature in XXL version.

These speakers are mainly designed to be installed behind a sonically transparent screen, LCR300, LCR500 and SUB600S have a remarkable small depth (less than 21cm / 8.26") compared with other similar products on the market.

The SAT150 with only 9.9cm / 3.9" can easily be installed in partition walls or in ceiling, as surround or even used as front speaker in small rooms.

# HOME CINEMA DEDICATED ROOM

XXL SOUND / XXS THICKNESS  
Be prepared for breathtaking sound.



**SAT150**

With its mere 9.9 cm (3.89") depth, our SAT150 offers a great flexibility.



**LCR300**

Multipurpose sound and exceptional power for this compact speaker.



**LCR500**

Most powerful and detailed. Dedicated to large rooms.



**SUB600S**

Phenomenal power in the infra low frequencies and tight bass.

This collection is the answer to the most demanding movie buffs, it delivers great acoustic pressure with no distortion just like some of the best professional studio monitors. Power and precision for your private cinema room.

Three speaker models dedicated to various room sizes. One powerful subwoofer to be multiplied according to room size. Our Professional Custom Series collection brings a compact solution and allows you to **save space** by installing them "In wall" behind an acoustically transparent screen (only 21 cm / 8,26" depth).





**WATERFALL AUDIO**  
Professional Custom Series

## TECHNICAL DETAILS

SAT150	<p>TYPE</p> <p>RECOMMENDED AMPLIFIER *</p> <p>PEAK POWER</p> <p>IMPEDANCE (AVERAGE/MINI)</p> <p>EFFICIENCY (2.83V/1M)</p> <p>FREQUENCY RESPONSE (+/- 3 dB)</p> <p>BASS / MIDRANGE DRIVER</p> <p>TWEETER</p> <p>DIMENSIONS (width x depth x height in mm) (approx. inches)</p> <p>WEIGHT Kg (approx. lbs.)</p>	<p>2 way - 2 drivers, closed</p> <p>80 - 150 Watts</p> <p>300 Watts</p> <p>8 / 4 Ohms</p> <p>88 dB</p> <p>80 Hz - 28 kHz</p> <p>1 x 150 mm / 6" Atohm LD150</p> <p>1 x 20mm / 0.75" Atohm SD20</p> <p>570 x 98 x 430 / 22.44" x 3.86" x 16.93"</p> <p>10 kg / 22 lbs</p>
LCR300	<p>TYPE</p> <p>RECOMMENDED AMPLIFIER *</p> <p>PEAK POWER</p> <p>IMPEDANCE (AVERAGE/MINI)</p> <p>EFFICIENCY (2.83V/1M)</p> <p>FREQUENCY RESPONSE (+/- 3 dB)</p> <p>BASS DRIVER</p> <p>MIDRANGE DRIVER</p> <p>TWEETER</p> <p>DIMENSIONS (width x depth x height in mm) (approx. inches)</p> <p>WEIGHT Kg (approx. lbs.)</p>	<p>3 way - 4 drivers, closed</p> <p>100 - 300 Watts</p> <p>500 Watts</p> <p>8 / 4 Ohms</p> <p>91 dB</p> <p>80 Hz - 28 kHz</p> <p>2 x 150 mm / 6" Atohm LD150</p> <p>1 x 150 mm / 6" Atohm LD150</p> <p>1 x 20mm / 0.75" Atohm SD20</p> <p>570 x 204 x 430 / 22.44" x 8.03" x 16.93"</p> <p>17 kg / 37.4 lbs</p>
LCR500	<p>TYPE</p> <p>RECOMMENDED AMPLIFIER *</p> <p>PEAK POWER</p> <p>IMPEDANCE (AVERAGE/MINI)</p> <p>EFFICIENCY (2.83V/1M)</p> <p>FREQUENCY RESPONSE (+/- 3 dB)</p> <p>BASS DRIVER</p> <p>MIDRANGE DRIVER</p> <p>TWEETER</p> <p>DIMENSIONS (width x depth x height in mm) (approx. inches)</p> <p>WEIGHT Kg (approx. lbs.)</p>	<p>3 way - 4 drivers, bass-reflex</p> <p>150 - 500 Watts</p> <p>750 Watts</p> <p>8 / 4 Ohms</p> <p>92 dB</p> <p>60 Hz - 28 kHz</p> <p>2 x 180mm / 7" Atohm LD180</p> <p>1 x 150mm / 6" Atohm LD150</p> <p>1 x 28mm / 1.1" Atohm SD28</p> <p>570 x 197 x 751 / 22.44" x 7.76" x 29.57"</p> <p>31 kg / 68 lbs</p>

\* Important note : the use of an amplifier beyond its limits, provokes clipping of the signal which might lead to destruction of the speaker (burnt voices coils), these damages are not covered by our warranty.

# SUB600S

## KEYSTONE OF OUR SYSTEM

Phenomenal power in the infra low frequencies, SUB600S delivers thundering impact with extraordinary musical qualities, it will awaken your senses in a way that you have never experienced before.

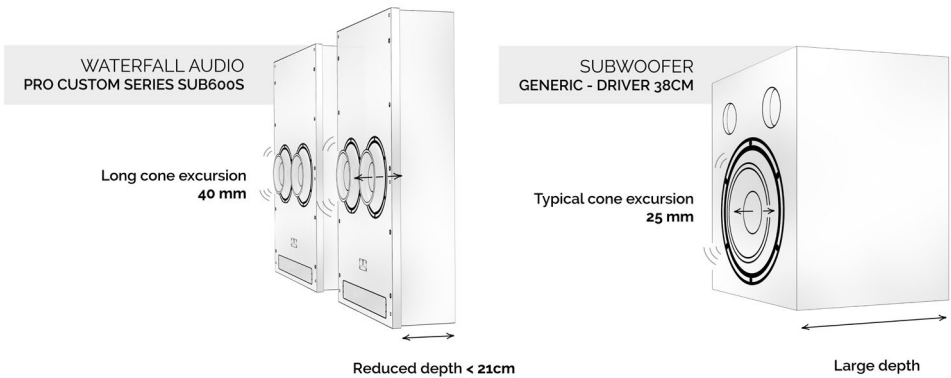

### KEY ADVANTAGES OF USING 4 X LONG EXCURSION DRIVER INSTEAD OF 1 X 38CM

1. 4 drivers provide more air displacement :  
Comparison of air movement capacity ( $\pi \times r^2 \times h$  in  $cm^3$ ) of :  
 $4 \times 23 \text{ cm } (r=11.5 \text{ cm} / 4.0 \text{ cm cone excursion}) > 1 \times 38 \text{ cm } (r=19 \text{ cm} / 2.5 \text{ cm cone excursion})$   
 $4 \times \pi \times 11.5^2 \times 4.0 = \mathbf{6\ 647 \text{ cm}^3} > 1 \times \pi \times 19^2 \times 2.5 = \mathbf{2\ 835 \text{ cm}^3}$
2. Each moving part (cone + voice coil) weighs 75g instead of 250g for a 38 cm : less inertia provides better impulse response with clear bass at low and high levels.
3. 4 overpowerfull driver magnets delivering incredible fast and furious bass.
4. 4 voice coils providing better heat dissipation and power handling.



## TECHNICAL DETAILS

SUB600S

TYPE	2 drivers - bass reflex
RECOMMENDED AMPLIFIER *	RS700 (2 x SUB600S) or S500EX (1 x SUB600S)
IMPEDANCE (AVERAGE/MINI)	8 / 4 Ohms
EFFICIENCY (2.83V/1M)	90 dB
FREQUENCY RESPONSE (+/- 3 dB)	29 Hz - 150 Hz
BASS DRIVER	2 x 230 mm / 9" Atohm LD230EX
DIMENSIONS (width x depth x height in mm) (approx. inches)	570 x 197 x 875 / 22.44" x 7.76" x 34.45"
WEIGHT Kg (approx. lbs.)	34 kg / 75 lbs

\* Important note : The RS700 program W1.0 is optimized for LCR300, LCR500, and SUB600S.

# DSP AMPLIFIER

## RS700 WATERFALL SPECIAL EDITION

BY ATOHM

The ultimate advanced power amplifier.



### RS700

Absolute luxury materials  
A breath taking experience awaits you.

Admire the design: solid brushed aluminium front plates and discover this "one of a kind" amplifier packed with 5 exclusive Technologies, driven by our proprietary DSP, it will enhance any of your music and films with unmatched performance.

More than 6000 hours of research and development  
for this exceptional amplifier.

The purpose of the RS700-WATERFALL AUDIO SPECIAL EDITION is to offer the best performances with a perfect control of all the parameters in total safety, making it the perfect amplifier to work in the cinema application with the Waterfall "Pro Custom Series" sub & speakers.

It has the advantage of being a rackable Unit.

ATHM

WATERFALL AUDIO  
SPECIAL EDITION



## EXCLUSIVE PROPRIETARY TECHNOLOGIES DRIVEN BY THE DSP

**X-GUARD™** Real time processing control of the driver's cone excursion ("SUB" mode)

**U-GUARD™** Real time processing control of power/voltage and advanced soft clipping to protect subs and speakers

**T-GUARD™** Real time processing control of thermal level of power stage and voice coil temperature of subs and speakers

**X-TEND™** Bass extension processing in the infra low frequency (20-35 Hz bandwidth). Active in "SUB" mode

**CSC™** (Cinema Screen Compensation)  
Progressive correction of the frequency response (>1Khz) to compensate the screen sound absorption for Left, Center and Right speakers (CSC™ only on "Speaker" mode)

## EXTENDED CONNECTIVITY

**XLR/RCA** analog inputs

**XLR outputs** driven by DSP for specific applications

**Innovative digital link** between RS700 (DIGITAL SPDIF IN/OUT)

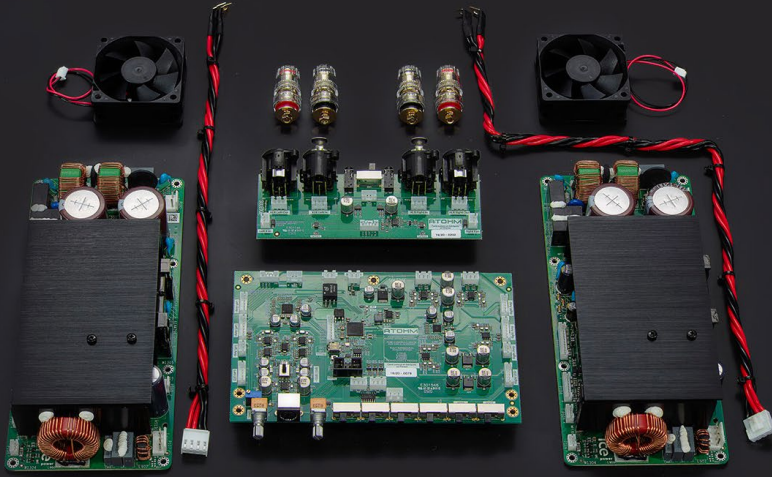

## TECHNICAL DETAILS (DSP PROGRAM W1.0\*)

RS700

NOMINAL POWER/4 OHMS	2 x 700 W RMS
NOMINAL LOAD IMPEDANCE	4 - 16 Ohms
FREQUENCY RESPONSE IN SPEAKER MODE	2 Hz - 45 kHz (-3dB)
FREQUENCY RESPONSE IN SUB MODE	2 Hz to 35-150 Hz or 2 Hz - 350 Hz (LFE)
DAMPING FACTOR (1 KHZ / 4 OHMS)	> 1000
DISTORTION THD+N AT NOMINAL POWER	Less than 0.06%
SIGNAL TO NOISE RATIO	110 dB
DSP INTELLIGENCE	32 bits - 295 MHz Sigma DSP
SAMPLING FREQUENCY	96 kHz - 24 bits audio resolution
DIMENSIONS (width x depth x height in mm) (approx. inches)	482 x 88 x 348 mm (rack) 450 x 88 x 348 mm (standard)
WEIGHT Kg (approx. lbs.)	8.7 Kg / 17,64 Lbs

\* Important note : The program W1.0 is optimized for LCR300, LCR500, and SUB600S.

# EXCLUSIVE TECHNOLOGY

## JETSTREAM TECHNOLOGY



*Applied to floorstanding speakers :*  
**Victoria XT - Niagara XT2 - Niagara XT3 - Niagara XT1 - Iguasçu XT**

### Glass brings one technical advantage & one challenge.

The ideal speaker enclosure should be as rigid & inert as possible. A glass enclosure is close to that and more inert than a wooden structure, so there will be no vibration from it.

The challenge is how to damp the energy inside the box. Our **"Jetstream Technology"** is the answer, with its high-tech jet engine appearance, it controls the speaker(s) within a reflective structure such as a glass enclosure.



BASED ON AN ALUMINUM TURBINE STRUCTURE,  
INTEGRATED INTO THE REAR OF THE SPEAKER,  
THIS EXCLUSIVE TECHNOLOGY HAS 5 MAIN FUNCTIONS :

It limits the return of the rear wave on the cone

It dampens mid and high frequencies

It preserves airflow for perfect bass response

It optimizes heat dissipation

It ensures the mechanical decoupling of the mid-bass driver and the glass structure.

# PROPRIETARY TECHNOLOGIES

## HEATSTREAM TECHNOLOGY\*



*Applied to on-wall speakers :*  
**Elora Evo, Hurricane Evo & Serio**

During long listening periods at high sonic levels, the drivers receive a lot of power and the voice coil tends to heat up considerably causing the driver to lose some of its efficiency and some electrical parameters are also modified.

Traditionally only the magnet is dissipating that excess heat on its own, but in compact speakers the magnets are reduced in size and therefore have a limited capacity to cool down on their own, leading to overheating and distortion.

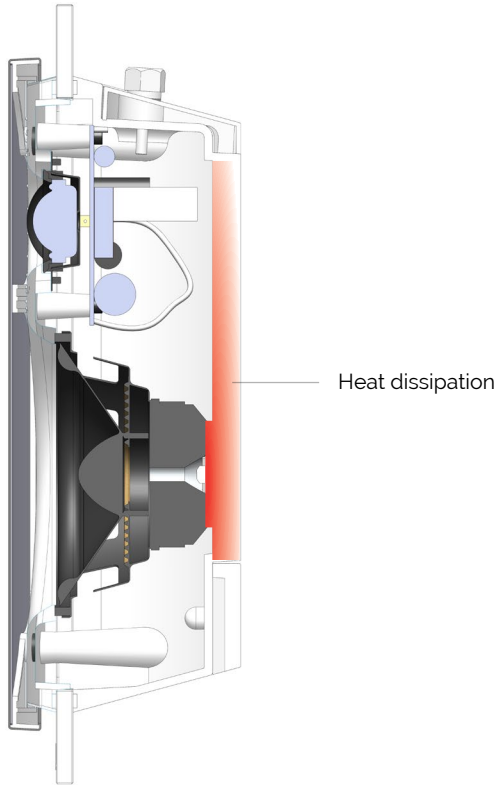

The purpose of this patented technology is to limit these effects and to provide an exceptionally high power handling by coupling the driver magnet to the aluminium cabinet. Excess heat is dissipated from the voice coil; the speaker enclosure becomes a heat dissipater.

With Heatstream technology, we reach unprecedented power handling levels and sonic characteristics, previously unheard of in such a compact design.

# CUSTOM DESIGN SPEAKER LAGOON YACHTS

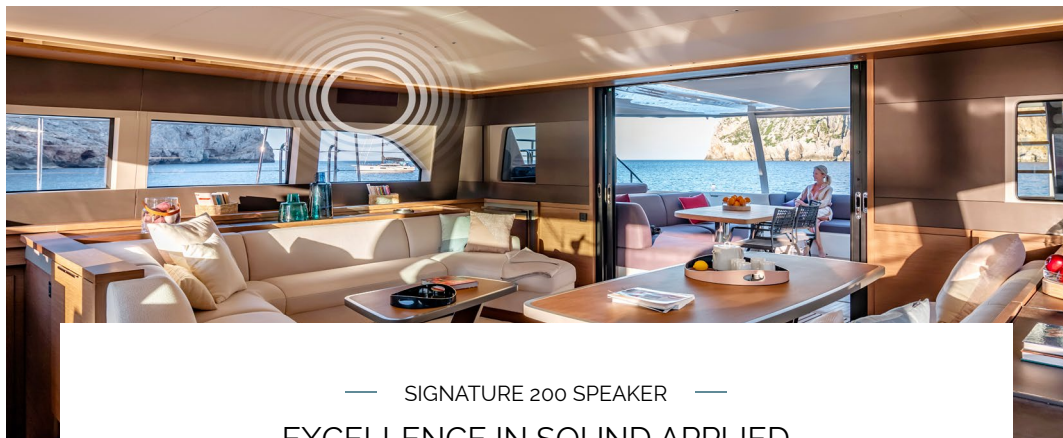

— SIGNATURE 200 SPEAKER —

## EXCELLENCE IN SOUND APPLIED TO LAGOON LUXURY CATAMARANS

A thousand miles away from standard solutions, Waterfall Audio design department in partnership with Access Images developed the SIGNATURE200, an exceptional compact speaker with outstanding performances to specifically fit into the SIXTY and SEVENTY catamaran series architecture. With this exclusive and specific design Waterfall Audio shares its excellence in sound across the seas worldwide.

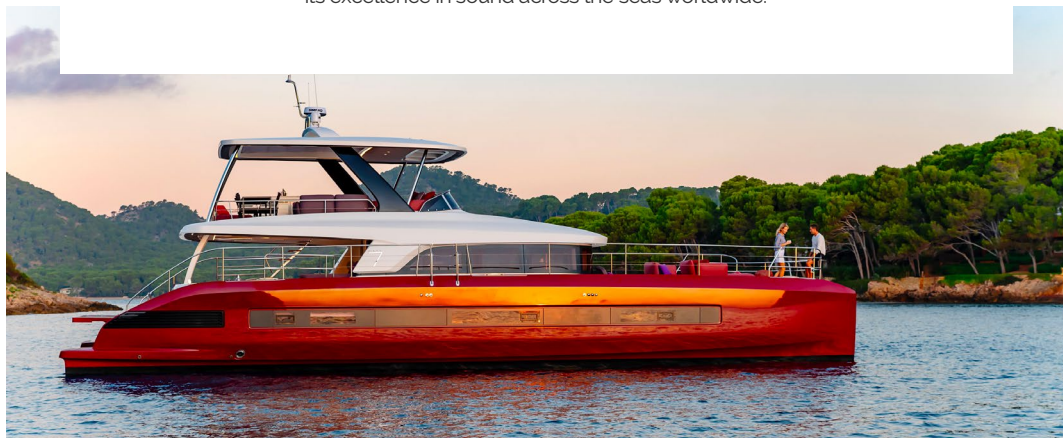

CRÉDITS PHOTOS : NICOLAS CLARIS



— CUSTOMIZED SPEAKER —

## SIGNATURE 200

Using very high-tech components and highly technical expertise, the "SIGNATURE 200" is installed in a «mirror» configuration, in order to optimize the sonic experience in a wide listening area.

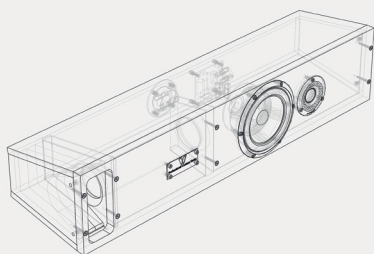

### SIGNATURE 200 TECHNICAL DETAILS

- Specific time alignment crossover for controlled sound distribution
- Neodymium tweeter for the finest precision in your favourite music.
- Bass driver featuring a special alloy membrane for pure and impactful sound
- Air vent with linear air flow for natural and deep infrasonic bass.

For further information,  
please contact your nearest dealer  
or distributor or visit our website :

[www.waterfallaudio.com](http://www.waterfallaudio.com)

Création graphique : Studio614

Crédits Photographies :

Sébastien Veraguas - VSI (Cinema Room)  
Art Cinema (Serio - Poland) - Chris B Design (Serio)  
Nicolas Claris (Lagoon - Beneteau)

## **WATERFALL AUDIO**

ZA Les Praderies - 83570 Carcès - France

Phone : +33 (0)4 98 05 11 30  
[export@waterfallaudio.com](mailto:export@waterfallaudio.com)

Made in France. 5 years warranty on speakers, 2 years warranty on amplifiers (parts & service).  
We operate a policy of continuous improvement and reserve the right to amend designs and specifications without prior notice.



All drivers are developed and manufactured by ATOHM (France)



