

LBC Manufacturing

“EZ-Tank”

GRAVITY FLOW Liquid

Bleach Chlorinator

US Patent Pending

"Copyright Notice"

No part of this publication may be reproduced, stored in any retrieval system, or transmitted in any form or by any means, electronic, mechanical, photocopying recording, or otherwise without the prior written permission of LBC MFG.

LBC Manufacturing
P.O. Box 454
Fayetteville, TEXAS 78940

(979) 826-0139 off.

www.liquidchlorinator.com



THIS PRODUCT WAS EVALUATED AS A
CHLORINE DISINFECTION DEVICE AND MEETS OR EXCEEDS
THE APPLICABLE REQUIREMENTS OF STANDARD 46

RECOMMENDED INSTALLATION INSTRUCTIONS

**** LBC Manufacturing recommends installation by TCEQ licensed and trained installers. ****

1. Locate the Aerobic System Holding/Pump tank
2. Remove the green access lid mounting screws and remove green access lid.
3. Install vertical sensing pipe into Holding/Pump tank. Ensure sensing pipe is resting on the bottom of the Holding/Pump tank. Cut the sensing pipe off below the top of the Holding/Pump tank lid, and secure the sensing pipe to remain vertical in the Holding/Pump tank
4. Using PVC Cleaner and PVC glue, attach the barb fitting adapter (supplied on the end of EZ-Tanks vinyl tubing) to the sensing pipe.
5. Place the EZ-Tank reservoir inside the holding tank access riser. (EZ-Tank reservoir rests on the secondary safety lid inside the holding tank access riser. If the holding tank access riser does not have a secondary safety lid, replace with new access riser that accommodates the secondary safety lid to code.)
6. Next, drill 4.25 inch hole in center of holding tank access lid. (this allows the fill lid to be accessed without having to reopen the holding tank lid) Next, Re-Install holding tank access lid and replace mounting and safety screws.
7. Open EZ-Tank gasketed fill lid. Fill with 6% -10% sodium hypochlorite. Once filled, Replace the gasketed fill lid ensuring a firm secure seal. (If the fill lid is not tightened securely, a vacuum will not form and reservoir will empty sodium hypochlorite contents into Holding/Pump tank prematurely.)

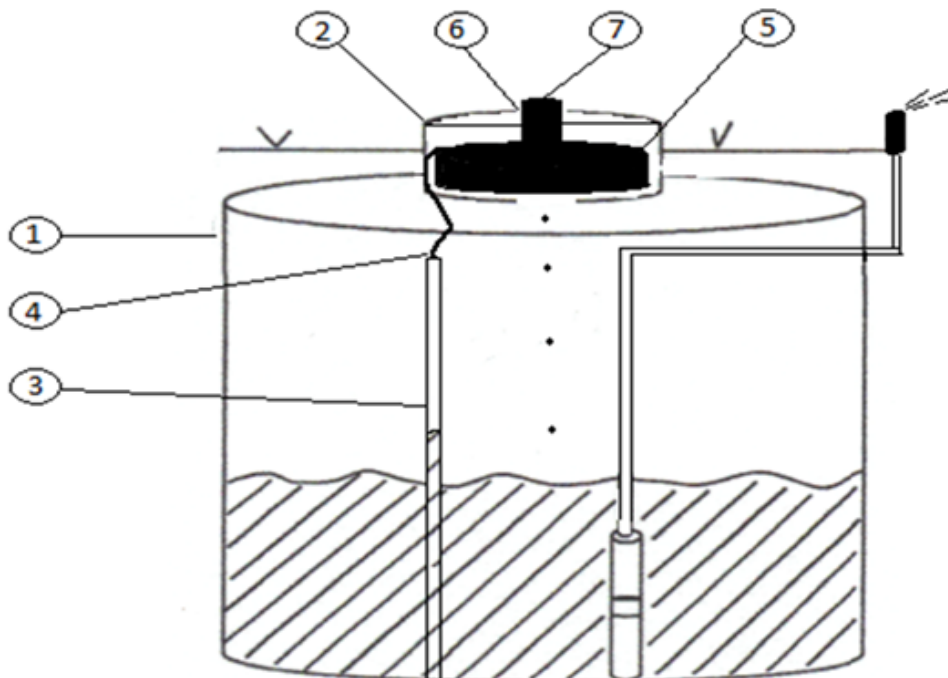

CHLORINE DISINFECTION DEVICE PERFORMANCE

The LBC MFG “EZ-Tank” is a proven disinfection device that meets the applicable requirements of NSF standard 46 for Chlorine disinfection devices. The EZ-Tank is listed as a certified chlorine disinfection device for secondary treated effluent. Certification requires the device to be used with 6-10% sodium hypochlorite (household bleach) The EZ-Tank Disinfection device is a gravity flow product that applies disinfectant to a holding tank as the water level rises thus giving the ultimate amount of contact time for the disinfectant to work.

THE LIQUID CHLORINATION PROCESS

LBC Manufacturing designed and built the “EZ-Tank” to provide years of trouble-free service. It is constructed from durable Polyethylene material which can withstand the corrosive nature of Sodium Hypochlorite (Household Bleach). It has been tested to NSF/ANSI Std 46 and has proven to function more consistently, at a lower operating cost, than any other disinfection method.

The basic function of the Liquid Bleach Chlorinator is to introduce disinfectant to the effluent water in the Holding/Pump tank as the effluent enters. The longer the contact time the disinfectant has to interact with pathogens, the better it disinfects. The ideal method is maximum contact time for minimal pathogen survival.

LIQUID CHLORINATOR OPERATION AND MAINTENANCE

It is the Owner's *Responsibility* to operate and maintain the Liquid Chlorinator to the best of their ability.

If Service is required, refer to the Data/Service Plate located on the Fill Lid of the Liquid Chlorinator.

The Liquid Chlorinator uses 6-10% Sodium Hypochlorite (Household Bleach). Do not use any other products and or chemicals other than specified. Always maintain a constant supply of disinfectant / Bleach in the Chlorinator Housing at all times. The rate of disinfectant/Bleach usage will vary with individual homeowner water usage. If disinfectant usage increases or decreases, call the service provider.

If flood waters, ants, chemicals etc.. other than Sodium Hypochlorite, enters the Chlorinator Housing, call for service.

****** Always use Personal Protective Equipment when Filling or Servicing the Chlorinator******

MONTHLY : Open the Chlorinator Fill Lid and Visually Inspect the liquid level the chlorine reservoir. Maintain a constant supply of Sodium Hypochlorite (Household Bleach) in the Chlorinator Housing and reservoir at all times. Check Sprinkler discharge for Chlorine residual. If Service is required, refer to the Data/Service Plate located on the Fill Lid of the chlorinator reservoir

PERIODICALLY: Open the Chlorinator Fill Lid and Visually Inspect the Chlorinator for debris such as dirt, grass clippings etc. Check Sprinkler discharge for Chlorine residual. If Service is required, refer to the Data/Service Plate located on the Fill Lid of the Chlorinator reservoir.

YEARLY: Visually inspect the Chlorinator Housing for any damage from lawnmowers, etc.
Remove dirt/ant build up , grass, etc. from Chlorinator Housing Fill Lid. Check Sprinkler discharge for Chlorine residual.
If Service is required, refer to the Data/Service Plate located on the Fill Lid of the Chlorinator reservoir

FOR INTERMITTENT PERIODS OR EXTENDED PERIODS OF NON-USE

The EZ_Tank is designed to function under normal use or Intermittent periods of use. If periods of non use exceed 6 months , drain Chlorinator Housing and refill with 6-10% Sodium Hypochlorite. If Service is required, refer to the Data/Service Plate located on the Fill Lid of the Chlorinator reservoir.

OFF LOADING AND PACKING INSTRUCTIONS

"WARNING!!! DO NOT DROP OR CRUSH"

It is the Owner's *Responsibility* to operate and maintain the Liquid Chlorinator to the best of their ability. If Service is required, refer to the Data/Service Plate located on the Fill Lid of the Liquid Chlorinator.

******Always use Personal Protective Equipment when Filling or Servicing the Chlorinator******

TROUBLESHOOTING/REPAIR INSTRUCTIONS

General Visual Inspection

1. Check to ensure Aerobic System is functioning properly.
2. Collect effluent sample from sprinkler head and perform chlorine test.

If no chlorine is detected, refer to section below.

Chlorinator not functioning properly:

1. Check Level of sodium hypochlorite in reservoir
2. Check to ensure Flooding event has not occurred. If Flooding event has occurred, drain Chlorinator Housing and reservoir and refill with 6-10% Sodium Hypochlorite.

Sources for Replacement Parts

Replacement parts or components may be purchased at

P.O. Box 454, Fayetteville, TX 78940 / Office (979)-826-0139
www.liquidchlorinator.com

INSTALLER OF RECORD _____

ADDRESS OF INSTALLER _____

INSTALLER PHONE # _____

AEROBIC SYSTEM INFO _____

DATE OF INSTALLATION _____

