

Special Issue
DEC 2011

SPOKE' N WORD



The Langley Mostly British Motoring Club

The LANGLEY MOSTLY BRITISH Motoring club had the opportunity to visit the world famous Earl Tucker at Tuckers Tin Farm in Surrey . Earl and his wife spent time with the group showing his car collection and his brothers trains . From Hot Rods, not Earl's favourite, to classic American cars and memorabilia galore , Earl has it all.





A great Idea for
your bathroom
mirror.



SPOKE' N WORD



MARK YOUR CALENDARS

Event date	Event	Location	Registration	Contact
April 22, 2012	St George's Day British Motoring show	Fort Langley Community Hall	Registration at www.lambscarclub.com	John or Betty Walkden lambsmc@telus.net
June 16th 2012	Czorny Center Dad's day	Czorny Centre Surrey BC	See www.lambscarclub.com	lambsmc@telus.net
June 24, 2012	Druids and Fluids Drive	Langley Surrey area	See www.lambscarclub.com	lambsmc@telus.net
Sept 22	Fall Crawl	Langley Surrey area	See www.lambscarclub.com	lambsmc@telus.net

LAMBERS:

In case anyone is interested, the registration for the 2012 edition of **Spring Thaw** is now open. Details and registration particulars are at:

<http://www.classicaradventures.com/2011/12/2012-spring-thaw-adventure-entries-open/>

Send you **FOR SALE** Items to the web and see the dollars come in?

Check it out!!! Contact mrmartinross@gmail.com



search ID: njun144

"IN FIFTY YEARS, THIS CAR WILL BE A CLASSIC AND YOU'LL GET BACK FIVE TIMES WHAT YOU PAID FOR IT!"

Special Issue
October 2011

SPOKE' N WORD



The Langley Mostly British Motoring Club

LAMB cars shine at the Langley Cruise In 2011

It was a hot summer's day on Sept 10th at the Langley 2011 Cruise in. While we were surrounded by the nostalgic cars of the American giants, the British flag waved proudly over the Lamb Cars at the show. Visitors in the tens of thousands descended on the show and many stopped and talked about the cars in our group.

The weather was great and we had some shade throughout the day at the Douglas Park show area. There were over 250 cars in the park with many in full restoration dating back to the early 1900's

Be sure to mark your calendars for next year and the British cars can once again strut their stuff and leave some additional oil marks in the Cruise In.

If you more pictures send them to the club email and we will post on the web.

Cars shown included

Ed Cowx- 68 TR 250
James Bond – 97 Aston Martin DB7
Carole Borgens – 65 Jaguar 3.8S
Victor Russell - 59 TR3A
Kathy Hahn – 59 Bug Eye Sprite
Kerry Turner – 63 Morris Traveller
Mike Boyle- '97 Lotus Esprit V8
Lyle Pona – 52 MGTD, 63 and 64 Corvairs
Fred Van Aggelen - 58 Morris Oxford
Marty Ross - 58 Morris Minor 1000

FALL 2012

SPOKE' N WORD



WAX on WAX Off

The first of many opportunities to learn about detailing your car was presented October 3 at Foreman's Auto Body . Gary Wedemeyer from Meguiar's demonstrated how to get the best results using many application and polish methods.

Attendance was 30, all keeners wanting to learn more about the finer points of protecting their cars' finish, including some of us with "show" cars needing to improve our product knowledge. It's one thing to read the label in the store, but quite another to be shown correct application techniques which get the most from the product. Seeing Meguiar's new product line was added to the experience.

Watch for Session 2 planned for the Spring



Mark your Calendars
2013 St George's Day
Motoring Show is
April 21 2013
at the Fort Langley
Community Hall on
Glover Road

Membership Dues are
due by December 31 for
the 2013 calendar year.



Auto jumble successful in spite of the weather



A wet day did not dampen the spirits of all in attendance. Sold out indoor tables, a crush of bodies intent on purchasing parts, and an almost "reunion" sense of camaraderie in the building contributed to the great success of this, the first of our AutoJumble events

The event finished with an over \$250 profit that was donated to the Big Brothers and Sisters of Langley from the club, exceptional since all costs were kept low, especially tables at \$20. and no admission fee. The kitchen did well, sales were brisk and coffee and muffins were complimentary to the early set-up crowd. Outside table space was not filled due to the weather, and only one car for the Car Corral.

Those with sales tables reported good sales and an enjoyable day. Many members from other clubs from Vancouver to Chilliwack came out to see what was for sale, and it turned into a great day to catch up at end of season.

Your executive is already scouting out larger buildings for next year and will be able to finalize plans, date and location by December. Another successful LAMB event completes and will be added to the 2013 calendar, possibly somewhat earlier in the year for weather concerns.

LAMB Members Fly High

Being a LAMB Member has great benefits. Great cars, great times and now a great addition of a membership to the **Langley Museum of Flight**.

The membership provides LAMB members with access to the Museum and their special events. Museum membership also provides free entry into the **Seattle Museum of Flight, Chilliwack Military Museum and BC Rail Museum**. **In addition there is a 15% discount off purchases in the Gift Shop. You will receive the quarterly newsletter and enjoy all guest privileges.** These memberships are for the named person and you will receive your card in January; your spouse or guest accompanying you into the museum will pay the regular entry fee.

We look forward to an expanded relationship with the museum, over time, and anticipate coordinating events together. This is a welcome offering for our club and we thank the museum for extending their generosity.

Next time you drive by, look for the recently donated Conair "Firecat", in red and white on the runway side of the museum.



<http://canadianflight.org/>

If My Body Was a Car

Scary how true it is!!

If my body was a car, this is the time I would be thinking about trading it in for a newer model. I've got bumps and dents and scratches in my finish and my paint job is getting a little dull ...
 But that's not the worst of it. My headlights are out of focus and it's especially hard to see things up close. My traction is not as graceful as it once was.. I slip and slide and skid and bump into things even in the best of weather.. My whitewalls are stained with varicose veins.
 It takes me hours to reach my maximum speed. My fuel rate burns inefficiently. But here's the worst of it --
 Almost every time I sneeze, cough or sputter, either my radiator leaks or my exhaust backfires!

Just a Chuckle!



"With a classic British sports car it's the only way you're guaranteed the wind in your hair."



"it's easy, lady...just follow the oil leaks!"

Hi Gang

Spotted this cartoon from July 1954 on the future of cars Looks like we are getting close

Will It Come To This?

"COMFORT" GADGETS ARE MAKING DRIVERS LAZY, ACCORDING TO A TORONTO DOCTOR.

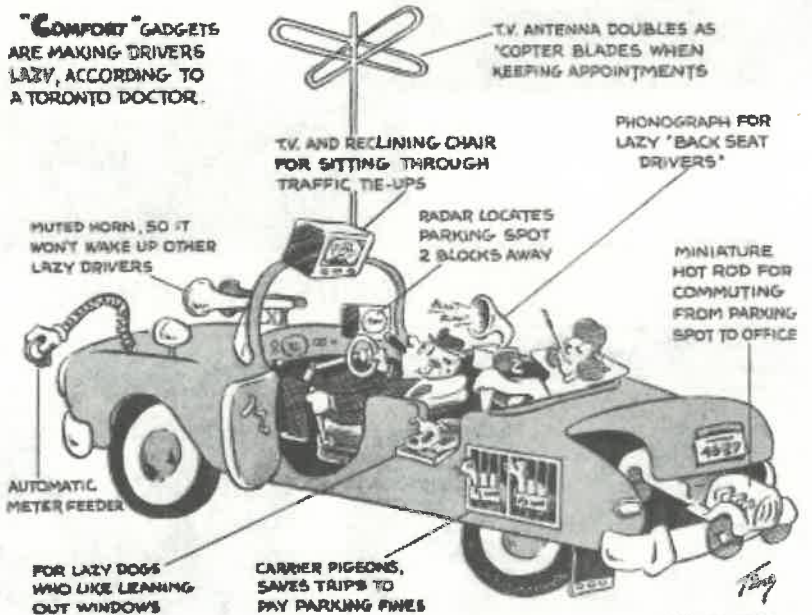

July 24, 1954

Got a joke, cartoon or a funny story, send it along and we will share with LAMBers
 mrmartinross@gmail.com

Largest Swap Meet and Classic Car Show in California

On October 14th in Pomona, just east of LA, I had the chance to go to a car swap meet that you would not believe. There was well over 800 booths of various car parts, memorabilia and specialty products on display. People started arriving a 5 am for the swap meet. I got there at 8 am and the parking lot was full. It holds 10000 cars.



At the same time they had a car corral for selling cars that had over 250 cars and show area of 1000 cars.

I could have spent all day but it was 106 degree F and my old body said to go lie-down. I was tempted to buy, sadly I came home with a Tee shirt

Apparently they do this 5 times a year. They hold the same event with just Harley and other Motorcycle parts.



For us O.F. as we change rides



Make your **scooter** customized with these fibreglass shells

Welcome New Members

New members

#101	Adrian Moore/Trish McAuley	1976 TR6 / 1967Herald
#102	Dave Gray	65 Hillman, 52Morris, 69 Morgan, 56Land Rover
#103	Joel & Tracy Stobbe	59Jaguar Mk IX
#104	Keith Major	'70Austin 1800
#105	Bill Grant	Morris 50,59,60 +53 Vaux Ute
#106	Darrell Unrau	62 MGA, 66 Jag 3.8, 88 Jag V Plas
#107	Kelly McPerson	TR3, 7, Spitfire

Returning members

#49 Kurt & Brenda Locken TVR's

In memoriam

Randy Schultz's wife, Jane, passed away recently. Jane had attended our 10th anniversary barbeque. In lieu of flowers, the club will send a donation to Randy's charity of choice

Upcoming Events

December 13, Club meeting Willowbrook Lanes 7:30

Yearly Dues \$30 deadline Dec 31, 2012

Regalia



LAMB Regalia for Sale

Club Jacket – Mens or ladies only Women's size Large in stock Only ; \$45.00

LAMB Grill Badges \$30.00

St. George's Show T-Shirts \$5.00

Contact : John Walkden - lambmc.telus.net



LANGLEY AREA MOSTLY BRITISH MOTORING CLUB

President : Michael Boyle - michaelboyle@shaw.ca

Vice President - Lyle Pona lpona@shaw.ca

Past President - Carole Borgens caroleborgens@shaw.ca

Secretary:
Denis Copley mrdee@telus.net

Treasurer John Walkden lambmc@telus.net

Membership- Victor Russell vtruss59@hotmail.com

Website: Martin Ross mrmartinross@gmail.com

Appointed positions ::
Newsletter Editor Marty Ross
Scrapbook/Historian John Walkden
Events The Executive
Regalia John Walkden

Club Website: www.lambscarclub.com
Club email address: lambmc@telus.net

The club, nor its members, take responsibility for inaccuracies, errors and omissions in this publication.

Tips and takes

Float Adjustments on SU carb

A critical, yet often overlooked area of SU carbs is the proper setting of the floats. This is a very important step! Setting the float level so that you don't run out of gas while driving will get you from point A to point B, but if you're going to do it, why not do it right?

Well, because it can be a pain in the butt. However, if your float levels are not set correctly, the level of fuel in the nozzles will not be correct either, exposing more or less of the needle than is optimum ([more info](#)). If you have visited the SU links above, you will have read a few different methods for setting the floats. I recommend using a float gauge (if you have one) or some method of visual inspection of the float level:

- Mark a line on the sides of your float bowls that is 22mm-24mm from the top lip of the bowls.
- Attach a length of clear plastic tubing (ala fish tank stuff) to the outlet on the bottom of the float bowl. *Be careful, you're dealing with gas!*
- If you have a mechanical fuel pump, disconnect the coil. Electric pump guys can never mind. To make it easier on your starter, you should also remove the spark plugs.
- Make sure your car is out of gear and the parking brake is on.
- Turn over your motor (key to "ON" for electric pump guys) until the fuel in the plastic line stabilizes. Compare this to the mark you made on the float bowl.
- Adjust your float lever until the fuel in the line matches up with the mark on the float bowl.
- Lather, rinse, repeat.
- Now go and reset the throttle balance, sync the carbs, set the mixture, and you're off!! Simple...

From <http://www.jetlink.net/~okayfine/su/sumain.html>

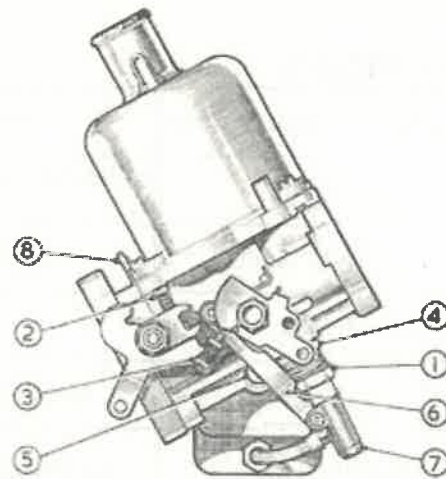

FIG. 3.2 EXTERNAL VIEW OF THE H54 CARBURETTOR.
1 Jet adjusting nut. 2 Throttle stop screw. 3 Choke or fast idle screw. 4 Jet locking nut. 5 Float chamber securing nut. 6 Jet link. 7 Jet head. 8 Vacuum ignition take off.

Got a car for sale or want to buy!!!!

Send you information to
mrmartinross@gmail.com
and we will put it on the
website for FREE



A 1950's labour intensive Dagenham production line at the Ford factory.

Send us the Tips so we can all benefit from your expertise, findings and knowledge

Show Edition
June 2012

SPOKE' N WORD



Don't Rain on Our Parade

May 21, was a raining drizzly day for a parade but that did not dampen the enthusiasm for the 90th May Day parade in Fort Langley.

The clouds parted for most of the parade route making the audience and organizers pleased with the turnout.

The club had 5 cars for the event to carry the councillors and Mayor Jack Frose in the parade and while the councillors and Mayor Frose decided to walk, our cars carried their banners throughout the parade. Carole Borgens and her 1965 S type Jaguar lead the way followed by Marty Ross' 1958 Morris, new member, David Smith and his Jensen Healy, Mike Boyle and a Lotus Elan and Chris Bennett and his classy 1961 Jaguar XK150

The crowds were all along the parade route with great comments on our club cars.

The event is a fund raiser for the club and contributes to the events and activities of the club throughout the year

We encourage all to join the fun and include their cars in the next parade.



Welcome to our new members

Byron Taylor	Jaguar XJ6
Hugh & Nancy Dick	1949 Triumph 2000 Roadster
David & Margret Smith	Jensen Healy
Adrian Moore/Trish McAuley	TR6 / Herald
Dave Gray	Hillman, Morris, Morgan, Land Rover

Upcoming Events

- Langley Parade June 16 Czorny
- Center Dad's Day June 16
- Druids & Fluids Drive June 24
- Canada Day – Langley July 1 Minter Gardens Show July 15
- Langley Cruise-In September 8
- www.langleycruise-in.com
- Hougen Park British Picnic
- Fraser Valley Club September 9
- Fall Crawl September 22, 23

More Events

Other Events and Car Shows

June		July	
Jun 01 to 03 TCT- W.Cdn Vintage Trailer Revival Mission, BC (604) 813-7305	Jun-16 Hot Rods & Classics Customer Appreciation Night Chilliwack, BC (604) 792-9005	Jul-01 Jelly Bean Autocrafters Canada Day Show & Shine Surrey, BC (604) 594-6800	Burns Lake Show & Shine Burns Lake, BC (250) 692-5721
Vntg Trlr Jun-01 2nd Geoff McElgunn Scholarship Show & Shine Coquitlam, BC () -	Open- 6pm Jun-16 Langley Summer Sizzle Poker Run Langley, BC (604) 534-6044	Open Jul-01 "Woody's on Brunette" Show & Shine Coquitlam, BC (604) 939-7034	Open Jul-20 Aldergrove Festival Days 3rd Show & Shine Aldergrove, BC (604) 607-0247
Open Jun-02 Burnaby Heights Hats Off Day Show & Shine Burnaby, BC (604) 802-0490	Jun-16 Maximum Nova Acadian Cruise Surrey, BC (604) 302-8852 Nova/Acadian Chevyl	Open Jul-08 Mopar Madness Langley, BC (604) 930-4963	Open Jul-21 Bob & Dan's 15th Marine Pub Run Burnaby, BC (604) 435-2245
Open Jun 02 to 03 LeMay America's Car Museum Grand Opening Tacoma, WA (253) 779-8490	Jun-16 Mustang Hell's Gate Cruise Coquitlam, BC (604) 931-5045	Jul-08 Royal City Show & Shine New Westminster, BC (604) 524-4996	Open Jul-21 Oldsmobile Rocket Round UP Olds, AB (780) 417-4062
Jun-03 Model A Sunday Fort Langley, BC (604) 856-9796	Mustangs Jun-16 Czorny Center Dad's Day Surrey, BC www.lambscarclub.com	Open Jul-08 A&W Newton Show & Shine for Parkinsons Surrey, BC (604) 307-4565	Open Jul-21 Wellbrook Winery Classic Car/Motorcycle Show & Shine Delta, BC (604) 946-1868
Jun-03 Waterfront Festival "Open Class" Car Show Anacortes, WA (360) 299-9303	British Jun-17 Old Car Sunday In The Park Mission, BC (604) 463-4298	Open Jul 13 to 15 Cam Jammers Rod Run 2012 Lumby, BC (250) 546-0156	Open Jul-22 Boulevard 500 Car, Truck, Motorcycle Show & Shine Coquitlam, BC (604) 534-6044
Open Jun-06 Tim Hortons(United Blvd) Camp Day Show & Shine Coquitlam, BC (604) 515-4252	Open Jun-24 Victoria Swap meet Saanichton, BC (250) 654-0265	Jul 14 to 15 Duncan Antique Truck Show Duncan, BC (250) 743-7818	Pre-80 Open Jul-22 Langley Quarter Midget Assoc.Show & Shine Aldergrove, BC (604) 607-0247
Open Jun-09 AZZKIKR Custom Cycles 6th Show & Shine Surrey, BC (604) 539-1930	Jun-24 Chilliwack "Village Classic" Show & Shine Chilliwack, BC (604) 792-4576	Jul-14 Kilby Historic Site Car Show Harrison Mills, BC (604) 796-9576	Open Jul-22 Edgemont Village Show & Shine North Vancouver, BC (604) 980-8742
Jun-09 Newton Community Festival Car Show Surrey, BC (604) 501-5540	Pre 74 Jun-24 Napa Auto Parts Show & Shine Langley, BC (604) 513-9458	Classic Vintage Jul-14 Marpole Summerfest Show & Shine TBD Marpole,(Vancouver), BC (604) 802-0490	Pre-reg/open Jul-22 Agassiz/Harrison Lions Street Meet Agassiz, BC (604) 795-0282
Open Jun-10 19th Annual Church Parade Chilliwack, BC (604) 792-6290	Open Jun-24 Druids and Fluids Drive Langley, BC www.lambscarclub.com	Open Jul-14 ACM Car Show at LeMay Car Museum Tacoma, WA (253) 779-8490	Open Jul-22 12th "Tutto Italiano" Italian Car/Motorcycle Display Vancouver, BC (604) 430-3337
Open Jun-10 Morgan Crossing Car & Motorcycle Show Surrey, BC (778) 545-2673	British Jun-16 KMS Tools Coquitlam Show & Shine Coquitlam, BC (604) 522-5599	Show Jul-15 V.I.M.A. Summer Spectacular Victoria, BC (250) 881-1423	Italian Jul-15 Minter Gardens Classic Car Show Rosedale, BC (604) 794-7191
Pre-73		Show	

For Full Event Listing see :
<http://www.autoeventlist.com>

Show Edition
April 27th 2012

SPOKE' N WORD



The 7th Annual St. George's Day British Motoring show in Fort Langley was a huge success with over 75 cars, motorcycles, bus, taxis and vintage British motorcycles on hand. The crowds were large, and with Carole's promise of sunshine we basked in 20 degrees for most of the day.



The club was well represented with 27 cars overall, including Ian Newby's Double Decker bus, and taxi fleet. Ian commented he was worn out talking about the bus and taxis by the end of the day. The show was also highlighted by Dave Baron's 1954 Bentley, and a special appearance by Barry Lafbery's 1949 Rover 75. Not to be outdone, our new members Nancy and Hugh Dick, featured their 1949 fully restored Triumph Roadster 2000, which had the crowds buzzing all day. Jim and Irma Cave showed their rare Portafold trailer with matching Metropolitan tow car; a great crowd-pleaser.

Two new ideas were introduced this year; a silent auction and a raffle of a 1955 Chevy replica pedal car (donated by A&W), which raised over \$650 for Big Brothers and Big Sisters of Langley. It is expected after all expenses are accounted for another \$300-\$400 will be added to the donation.



Many thanks to all of the volunteers who manned the tables, sold tickets and made sure the day went without any problems. As well, a large thank you to Betty Walkden for again taking care of the registration.









Show Edition
April 27th 2012

SPOKE' N WORD



The 7th Annual St. George's Day British Motoring show in Fort Langley was a huge success with over 75 cars, motorcycles, bus, taxis and vintage British motorcycles on hand. The crowds were large, and with Carole's promise of sunshine we basked in 20 degrees for most of the day.

The club was well represented with 27 cars overall, including Ian Newby's Double Decker bus, and taxi fleet. Ian commented he was worn out talking about the bus and taxis by the end of the day. The show was also highlighted by Dave Baron's 1954 Bentley, and a special appearance by Barry Lafbery's 1949 Rover 75. Not to be outdone, our new members Nancy and Hugh Dick, featured their 1949 fully restored Triumph Roadster 2000, which had the crowds buzzing all day. Jim and Irma Cave showed their rare Portafold trailer with matching Metropolitan tow car; a great crowd-pleaser.

Two new ideas were introduced this year; a silent auction and a raffle of a 1955 Chevy replica pedal car (donated by A&W), which raised over \$650 for Big Brothers and Big Sisters of Langley. It is expected after all expenses are accounted for another \$300-\$400 will be added to the donation.

Many thanks to all of the volunteers who manned the tables, sold tickets and made sure the day went without any problems. As well, a large thank you to Betty Walkden for again taking care of the registration.









Show Edition
June 2012

SPOKE' N WORD



Don't Rain on Our Parade

May 21, was a raining drizzly day for a parade but that did not dampen the enthusiasm for the 90th May Day parade in Fort Langley.

The clouds parted for most of the parade route making the audience and organizers pleased with the turnout.

The club had 5 cars for the event to carry the councillors and Mayor Jack Frose in the parade and while the councillors and Mayor Frose decided to walk, our cars carried their banners throughout the parade. Carole Borgens and her 1965 S type Jaguar lead the way followed by Marty Ross' 1958 Morris, new member, David Smith and his Jensen Healy, Mike Boyle and a Lotus Elan and Chris Bennett and his class 1961 Jaguar XK150

The crowds were all along the parade route with great comments on our club cars.

The event is a fund raiser for the club and contributes to the events and activities of the club throughout the year

We encourage all to join the fun and include their cars in the next parade.

Welcome to our new members

Byron Taylor	Jaguar XJ6
Hugh & Nancy Dick	1949 Triumph 2000 Roadster
David & Margret Smith	Jensen Healy
Adrian Moore/Trish McAuley	TR6 / Herald
Dave Gray	Hillman, Morris, Morgan, Land Rover

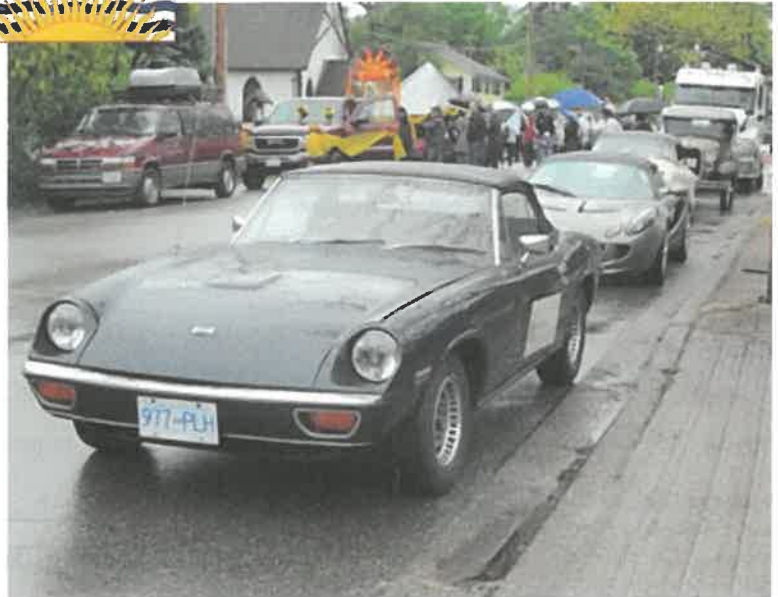

Upcoming Events

- Langley Parade June 16 Czorny
- Center Dad's Day June 16
- Druids & Fluids Drive June 24
- Canada Day – Langley July 1 Minter Gardens Show July 15
- Langley Cruise-In September 8
- www.langleycruisein.com
- Hougen Park British Picnic
- Fraser Valley Club September 9
- Fall Crawl September 22, 23

More Events

Other Events and Car Shows

June

Jun 01 to 03
TCT- W.Cdn Vintage Trailer Revival
Mission, BC (604) 813-7305

Vntg Trlr
Jun-01
2nd Geoff McElgunn Scholarship Show & Shine
Coquitlam, BC (-)

Open
Jun-02
Burnaby Heights Hats Off Day Show & Shine
Burnaby, BC (604) 802-0490

Open
Jun 02 to 03
LeMay America's Car Museum Grand Opening
Tacoma, WA (253) 779-8490

Jun-03
Model A Sunday

Fort Langley, BC (604) 856-9796
A/T Fords
Jun-03
Waterfront Festival "Open Class" Car Show
Anacortes, WA (360) 299-9303

Open
Jun-06
Tim Hortons(United Blvd) Camp Day Show & Shine
Coquitlam, BC (604) 515-4252

Open
Jun-09
AZZKIKR Custom Cycles 6th Show & Shine
Surrey, BC (604) 539-1930
Motorcycles Hotrods

Jun-09
Newton Community Festival Car Show
Surrey, BC (604) 501-5540

Open

Jun-10
19th Annual Church Parade
Chilliwack, BC (604) 792-6290

Open

Jun-10
Morgan Crossing Car & Motorcycle Show
Surrey, BC (778) 545-2673

Open
Jun-16
KMS Tools Coquitlam Show &

Jun-16
Hot Rods & Classics Customer Appreciation Night
Chilliwack, BC (604) 792-9005

Open- 6pm
Jun-16
Langley Summer Sizzle Poker Run
Langley, BC (604) 534-6044

Pre-Reg Open

Jun-16
Maximum Nova Acadian Cruise
Surrey, BC (604) 302-8852
Nova/Acadian Chevyl

Jun-16
Mustang Hell's Gate Cruise
Coquitlam , BC (604) 931-5045

Mustangs

Jun-16
Czorny Center Dad's Day
Surrey, BC www.lambscarclub.com

British

Jun-17
Old Car Sunday In The Park
Mission, BC (604) 463-4298

Open

Jun-24
Victoria Swap meet
Saanichton, BC (250) 654-0265

Jun-24
Chilliwack "Village Classic" Show & Shine
Chilliwack, BC (604) 792-4576
Pre 74.

Jun-24
Napa Auto Parts Show & Shine
Langley, BC (604) 513-9458

Open
Jun-24
Druids and Fluids Drive
Langley, BC
www.lambscarclub.com

British

July

Jul-01
Jelly Bean Autocrafters Canada Day Show & Shine
Surrey, BC (604) 594-6800

Open
Jul-01
"Woody's on Brunette" Show & Shine
Coquitlam, BC (604) 939-7034

Open
Jul-08
Mopar Madness
Langley, BC (604) 930-4963
Mopars
Jul-08
Royal City Show & Shine
New Westminster, BC (604) 524-4996

Open
Jul-08
A&W New on Show & Shine for Parkinsons
Surrey, BC (604) 307-4565

Open
Jul 13 to 15
Cam Jammers Rod Run 2012
Lumby, BC (250) 546-0156
Pre 72
Jul 14 to 15
Duncan Antique Truck Show
Duncan, BC (250) 743-7818
Trucks
Jul-14
Kilby Historic Site Car Show
Harrison Mills, BC (604) 796-9576

Classic Vintage
Jul-14
Marpole Summerfest Show & Shine
TBD Marpole,(Vancouver), BC (604) 802-0490

Open
Jul-14
ACM Car Show at LeMay Car Museum
Tacoma, WA (253) 779-8490

Show

Jul-15
V.I.M.A. Summer Spectacular
Victoria, BC (250) 881-1423

Open
Jul-15
Minter Gardens Classic Car Show

Burns Lake Show & Shine
Burns Lake, BC (250) 692-5721

Open

Jul-20
Aldergrove Festival Days 3rd Show & Shine
Aldergrove, BC (604) 607-0247

Open

Jul-21
Bob & Dan's 15th Marine Pub Run
Burnaby, BC (604) 435-2245

Open

Jul-21
Oldsmobile Rocket Round UP
Olds, AB (780) 417-4062

Olds

Jul-21
Wellbrook Winery Classic Car/Motorcycle Show & Shine
Delta, BC (604) 946-1868

Open

Jul-22
Boulevard 500 Car, Truck, Motorcycle Show & Shine
Coquitlam, BC (604) 534-6044

Pre-80 Open

Jul-22
Langley Quarter Midget Assoc.Show & Shine
Aldergrove, BC (604) 607-0247

Open
Jul-22
Edgemont Village Show & Shine
North Vancouver, BC (604) 980-8742

Pre-reg/open
Jul-22
Agassiz/Harrison Lions Street Meet
Agassiz, BC (604) 795-0282

Open
Jul-22
12th "Tutto Italiano" Italian Car/Motorcycle Display
Vancouver, BC (604) 430-3337

Italian

For Full Event Listing see :
<http://www.autoeventlist.com>

SUMMER
EDITION

SPOKE' N WORD



Member BBQ

Lyle and Diane Pona were gracious hosts of a BBQ after the parade for the members and guests. It was great afternoon of rare sunshine. Good Food and a few laughs were the order of the day. Make sure you read your emails for information on events like this. We want to see you there.



CANADA DAY SHOW

The Langley Canada Day show was held at langley Secondary off 216th avenue. We had a good showing of 12 cars at the show and even Weather cooperated. It was a good event and could better with a little for planning by the Langley Committee. Many thanks to the attendees and Carole for her time and efforts.

LAMB 10th Birthday Celebration

LAMB 10th Anniversary Picnic and BBQ
Mark your calendars for the 10th anniversary, AUGUST 26, 2012 picnic and celebration at Adrian Percival house in Aldergrove. Meet al the Lamb Clubs members and some guests from the past.

This will be our biggest event and we need everyone to attend with their cars. Lots of room , food and fun. Contact John Walkden for details or email lambsmc@telus.net (sorry no Roast lamb on the Menu)



We all Love a parade ... Especially LAMB Cars.....

The Club has bee active in several parades over the spring and summer season. The Fort Langley Parade in May, the Langley Days Parade in June and lately the Aldergrove Days parade in July. All three events we were the entourage for the Langley mayor and Councillors. These are fun events for the club and the more the merrier for the events. A great time was had by all.

Auto Jumble OCT. 14 th

Time to clear out the basement, garage, shed and carports of lonely car parts and make some money as well. Our 1st of hopefully many, car parts and memorabilia sale will be held at **Location-Harmsworth Hall, 7170 232 St, Langley, across from the Chevron near Hwy 1, Exit 66.** There will be some space for car sales with proceeds from the registration of the Car Corral donated to Big Brothers. Book tables and outdoor space now as space is limited. Tell your friends and other British Autophiles that this is a day to locate those hard to find parts and accessories.

Registration forms are available on line or by contacting lambmc@telus.net

Mark Sunday October 14th on your calendar!
LAMB is having our 1st British Parts Autojumble

BRITISH PARTS
AUTO JUMBLE

Time-10:00AM-4:00 PM
British Car Sales Corral
Spares, Parts, Tools,
Literature, Magazines,
Collectables and
lots good times
British Food on sale

Contact lambmc@telus.net
Location-Harmsworth Hall,
7170 232 St, Langley,
across from the Chevron near Hwy 1,
Exit 66

Table or Outdoor Space
\$20.00

See www.lambscarclub.com details. Registration on reverse

Upcoming Events

- August 1 Lotus Car Club, east Fort Langley Drive (contact Mike), Start 7:30 p.m. Walnut Grove A & W (204St/88Ave.)
- August 4 - Cloverdale Berry Fest, small car show, \$20/car.
- August 9 - LAMB Club Meeting
- August 19 - Ladner Quilt Walk and Car Show, \$20/car
- August 26 - LAMB 10th Anniversary BBQ (at Adrian's property). Details Forthcoming
- Sept. 8 - Langley Cruise-In – meet early so we can drive in park together \$25/car (contact John)
- Sept. 9 - Fraser Valley British Motoring Club Hougen Park Picnic – Chilliwack Exit 99 (contact John)
- Sept. 13 - LAMB Club Meeting
- Sept. 28 - Fall Crawl to Summerland. Note new date. (contact Bence)
- Oct. 11 - LAMB Club Meeting
- Oct. 14 - LAMB Autojumble Sale and British Car Corral. Book your space early as there are only 14 inside tables (2-1/2' x 6'), \$20/table and 10 outdoor spots (10' x 10'), \$20/spot. Car Corral at \$20/car. To secure a place Please pay up front – no reserving without paying. (contact John)

September
EDITION

SPOKE' N WORD



LAMB 10th Birthday Celebration a Success

The 10th Anniversary celebration was a big success with 50 or so past and present members attending. The weather co-operated and Adrian Percival and his family put on a great BBQ and allowed us entry to his fabulous yard for the cars.

It was great event and social for the Lamb Group. 10 years ago, John Walkden, Kathy Hahn and Victor Russell started the group as casual organization for many British Car owners no matter what vintage, model or style.

Now we are a great group of cars and people who celebrate the vintage British cars with events such as the Fall Crawl, St. Georges day, Langley Cruise In and have lots of friends in other clubs and groups that join our bevy of cars.

Victor commented that we need to do this again in at least 5 years as it is not only fun but a great time to touch base with the members and non members.

By the way the motor cars provided a great show and Adrian's place made them shine even more

Many thanks to those who attended and the club executive for organizing the event.





Cloverdale Berry Festival

On August 4th, the Cloverdale berry festival had their annual show and shine. The hottest day of the year provided for a challenge to stay cool in the new Brick Yard mall where a flock of British cars were on display.

This is the first year the car show group used the new mall at Hwy 15 and Hwy 10. Many thanks to the Rexall and Starbucks for their air conditioning.

There were 15 cars and a truck on display and Hugh and Nancy's 1949 Triumph 2000 roadster took home second place, while Ed Cowx's TR250 had third.

One of the stars was an Austin A40 pick up that Roy Mitchell brought.

This could be a good future show for LAMB cars and other British cars. More signs and more active displays are planned for the 2013 show.



Ladner Quilt and Car Show Draws Big Crowds

August 19th, the Ladner Car show and Quilt Walk displayed over 300 cars throughout the Ladner village area.

We had 5 cars in the show including Hugh and Nancy's Triumph 2000 Roadster, John Walkden's MG, Dave Smith's Jensen Healey, Dave Baron's Bentley and Bob Smith's TR 7.

To compliment our cars, a Jag XKE, 2 Austin 7, a 55 Jag, a Mini and a few other British cars were part of the show as well. A good day was had by all.



Auto Jumble OCT. 14 th

Time to clear out the basement, garage, shed and carports of lonely car parts and make some money as well. Our 1st of hopefully many, car parts and memorabilia sale will be held at **Location-Harmsworth Hall, 7170 232 St, Langley, across from the Chevron near Hwy 1, Exit 66.** There will be some space for car sales with proceeds from the registration of the Car Corral donated to Big Brothers. Book tables and outdoor space now as space is limited. Tell your friends and other British Autophiles that this is a day to locate those hard to find parts and accessories.

Registration forms are available on line at www.lambscarclub.com or by contacting ambmc@telus.net

Upcoming Events

- Sept. 8 - Langley Cruise-In – meet early so we can drive in park together \$25/car contact Carole for preregistration.
- Sept. 9 - Fraser Valley British Motoring Club Hougen Park Picnic – Chilliwack Exit 99
- Sept. 13 - LAMB Club Meeting – new time 7:30 pm
- Sept 15 - Czorny show 2-4pm – Contact Carole
- Sept. 15 & 16- Fall Crawl to Summerland. Note new date. (contact Bence)
- Oct. 11 - LAMB Club Meeting – new time 7:30 pm
- Oct. 14 - LAMB Autojumble Sale and British Car Coral. Book your space early as there are only 14 inside tables (2-1/2' x 6'), \$20/table and 10 outdoor spots (10' x 10'), \$20/spot. Car Corral at \$20/car. To secure a place Please pay up front – no reserving without paying. (contact John)

Time for a Fall Clean Out of parts and accessories or a chance to Buy, Sell or Swap some !!!!!



Check the website for updates and contact information

2013

SPOKE' N WORD



Langley Area Mostly British Motoring Club



Mark your Calendars

**2013 St George's Day
Motoring Show is
April 21 2013
at the Fort Langley
Community Hall on
Glover Road**

**Registration available
on our Website**

In This Issue

- Events
- Tyres
- Just a Chuckle
- Auto Jumble
- St George's Day Show

It's hard to believe we are into march already. As someone reminded me that slope of life seem to be more slippery the older we get.

As we dust of the cars, replace the oil from the driveway, and figure why Lucas invented the wiring system, it's almost time for the St George's Day British Motoring Show in Fort Langley. Registration has been posted on the website. We encourage all members to attend in full force and bring along friends from other clubs to join in the fun.

This year we have managed to get a pedal car replica of a MINI from Langley Mini to raffle off to raise funds for Big Brothers, Big Sisters of Langley. Plus great music, the Canadian Museum of flight Airplanes and much more. Raffle Tickets will be available at the March 14, LAMB meeting at Willowbrook lanes and the show registration table during the show.

The St George's Day event team is well on the way to setting up the show, with Carole Borgens leading the way along with the Executive team.

The show is April 21, 10 - 4 pm at the Forth Langley Community Hall on Glover Road. Rain or shine (it never rains on our event, thanks Carole)

See you there.



Photo by Cam Hutchins www.carnut.ca

Flying High at Christmaswell a little later

The LAMB group celebrated Christmas in January with a dinner at Adrian's at the Airport in Langley. The dinner had 30 LAMBMC members and guests attending and although it was a little foggy and cool, the group raved about the food and atmosphere.

There were prizes and limited speeches. Just the way it should be.

Great food, Great Company and Good Times!



Don't forget that LAMB members are also members of the Canadian Museum Flight in LANGLEY.

Call Victor for Details

Just a Chuckle!

A Jugular: Classic Car preferred by the wealthier vampire

Song Parodies by Spinal Tappets

Listen to some revised classics including "While My TR Gently Leaks", "Rust in the Tin" and "Losing my Transmission" to name a few, or catch videos of the band performing classics such as "Johnny's Got a Brand New Stag". Folks, this is **Spinal Tappets. (website link below)**

http://www.snic-braaapp.org/UAT/index.php?option=com_content&view=article&id=8&Itemid=8



John's Car pre Bent Bonnet award
LAMBMC ANNUAL "BENT BONNET AWARD"



For surviving the untimely coming together, last summer, of a deer and the bonnet of their MGB, this, the not exactly coveted "BENT BONNET AWARD", was presented to John and Betty Walkden at the dinner at Adrian's at the Airport Event in January

It will be held by them until this time next year when it will be awarded to another member of LAMB, whose misadventure, we hope, also results in only bent metal

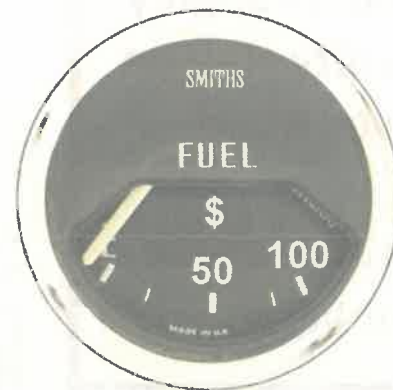

Got a joke, cartoon or a funny story, send it along and we will share with LAMBers
mrmartinross@gmail.com

Auto Jumble Set for Fall 2013

Gentlemen...and Ladies.... Start your cleaning!
We have booked September 29th for next Auto Jumble.
The Place Sullivan Hall at 63 ave and 152 Street in Surrey..

Details will be available soon on the website
www.lambscarclub.com.

Contact John Walkden at lambmc@telus.net for details

Upcoming Events

Wax on Wax off 2

Meguiar's Polishing Clinic 2 is scheduled for Wednesday, May 8, 6pm at Foreman's Auto Service, Langley. Wet sanding and polishing will be demonstrated as well as the correct use of many cleaning and polishing products. Sandwiches, coffee and pastries provided. For more info call Carole at [604-857-1837](tel:604-857-1837) or c_b@shaw.ca.

Sunday April 21, 2013 LAMBS - St Georges Motoring Show Fort Langley –
www.lambscarclub.com

Saturday, April 27th and Sunday April 28, 2013. Fraser Valley
Located at Otter Farm and Home Co-operative, 3650- 248 Street, Aldergrove, B.C.
<http://fraservalley.vccc.com/>

Saturday, May 18, 2013 Vancouver ABFM
http://www.westerndriver.com/?page_id=5288

Friday/Saturday May 24 and 25, 2013 - Coastal Swap Meet - Abbotsford - All Cars

Sunday June 23, 2013 - Vintage Car Club of Canada – Victoria Swap Meet

Saturday July 6, 2013 – CFB Esquimalt Chrome and Wheels Show

Sunday July 21, 2013 - Minter Gardens Classic Car Show - Chilliwack BC.

Friday July 19- Aldergrove days Show and Shine – Aldergrove High School

Regalia

LAMB Regalia for Sale

Club Jacket Women's size Large Only ; \$45.00

LAMB Grill Badges \$30.00

St. George's Show T-Shirts \$5.00

Contact : John Walkden – lambmc.telus.net



LANGLEY AREA MOSTLY BRITISH MOTORING CLUB

President : Lyle Pona
lpona@shaw.ca

Vice President – David Smith

Past President – Michael Boyle
michaelboyle@shaw.ca

Secretary:
Denis Copley mrdee@telus.net

Treasurer John Walkden
lambmc@telus.net

Membership- Victor
vtruss59@hotmail.com

Website: Martin Ross
mrmartinross@gmail.com

Appointed positions will be:
Newsletter Editor Marty Ross
Scrapbook/Historian John Walkden
Events The Executive
Regalia John Walkden

Club Website: www.lambscarclub.com
Club email
address: lambmc@telus.net

The club, nor its members take responsibility for inaccuracies , errors and omissions in this publication.

Tyre Markings

Tips and takes

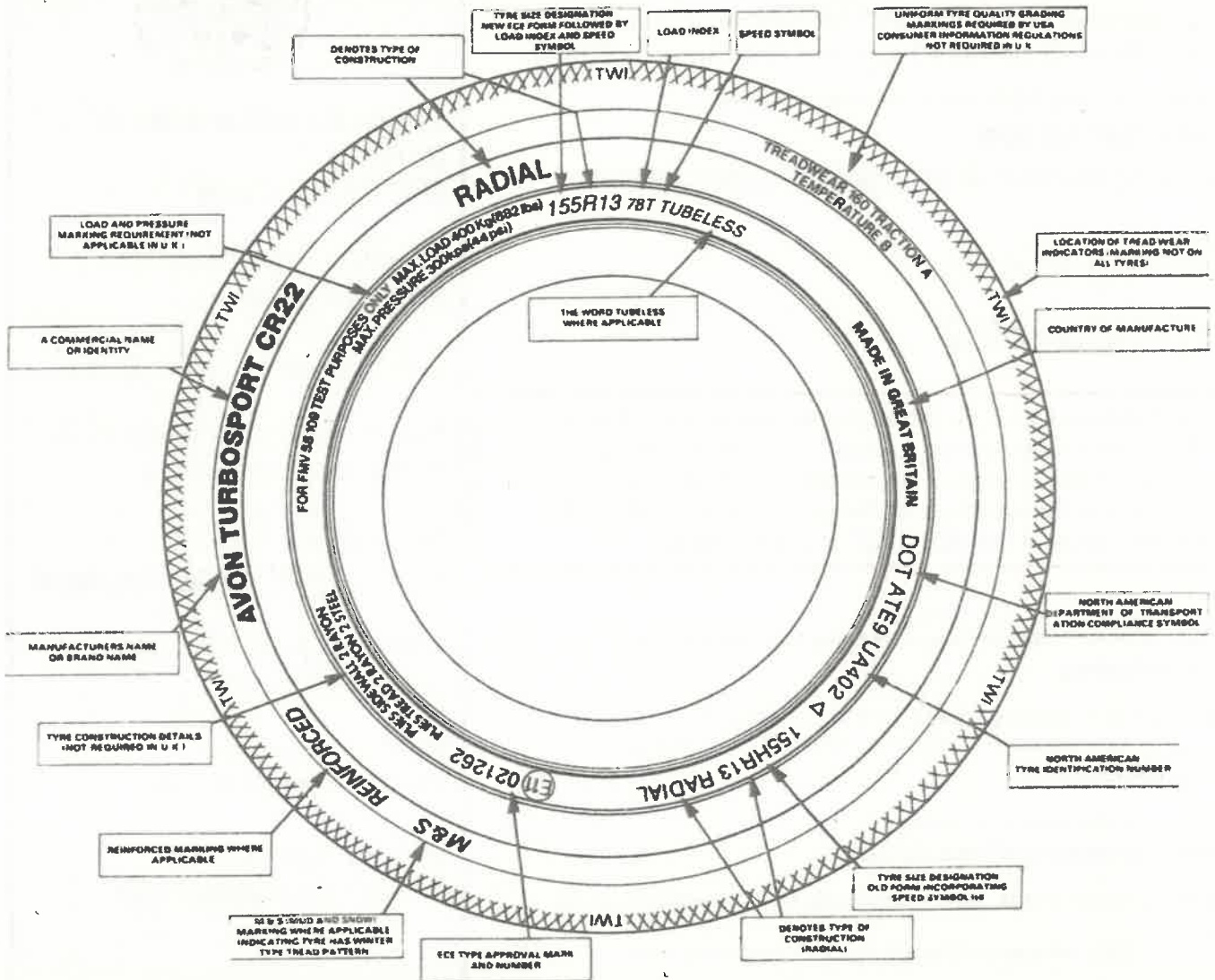

Got a car for sale or want to buy!!!! Parts, spares

Send you information to mrmartinross@gmail.com and we will put it on the website for FREE

Links to our Friends in Other Clubs

Olde English car Club – www.oecc.ca
 MG-Jaguar club – jaguarmg.com/
 Lotus Car Club--www.lotuscarclub.ca
 Rover Car Club-- www.roverclub.ca/
 Fraser Valley car Club www.britishcarclub.ca

Send us the Tips so we can all benefit from your expertise, findings and knowledge

**SPRING
2013**

SPOKE' N WORD



Langley Area Mostly British Motoring Club



**Big Brothers Big Sisters
of Langley**



Big Brothers Big Sisters receive Big Cheque from LAMB

Mary Reeves, from Big Brothers and Big Sisters of Langley were presented with a cheque for \$914.00 for the monies raised from the Kid's Mini Car Raffle held at the St George's Day Motoring Show in Fort Langley.

Cheque was presented by Lyle Pona, President of LAMB and Andrew Liu of Langley Mini

Weather didn't dampen our spirits.

The 8th annual St. George's Day British Motoring Show started a little wet and cool but the sun shone through by lunchtime and the display of 69 plus cars sizzled in the afternoon.

The show featured many LAMB cars and was highlighted with some very nice Jaguar's on the prowl. Twin XKE Jaguars manufactured only 11 days apart created a lot of interest, along with Morgan, MG, Triumph, Vauxhall, Lotus, Rolls Royce, Austin Healey, Morris, Met, Rover, London Taxis and of course, the Alvis Rolls Royce Ferret army vehicle that rumbled in with the fleet from Ian and Doreen Newby. What a fantastic showing!

A new feature this year was Nigel Mathews of Hagerty Insurance presenting the Hagerty Preservation Award. Nigel selected the Newbys' London Double Decker Bus, and the entire crew was on hand to accept the award.

The Mayor's Choice Award was presented by Mayor Jack Froese and his wife Debbie to the outstanding silver/blue Morgan belonging to Ken Miles.

This year we had a MINI battery powered replica car for kids, donated by Langley MINI to raise money for Big Brothers and Big Sisters of Langley. At the end of the day over \$900 was raised for them with raffle ticket sales. The winner, Denise, was thrilled and we are sure her Grandchildren will also be thrilled with their new gift.

At the end of the show a number of vehicles and their owners stayed and talked to interested visitors and enjoyed the sunshine (thanks again Carole). All cars started obediently at day's end (is this a record?) Next time yours doesn't and you can't identify the problem, think of the complexity of the Alvis Rolls Royce Ferret which refused to start. Where to begin...the carburetor adjustment for altitude; who knew? It was set for Las Vegas and didn't so much like "sea level". After its' keeper, Glen, gave it an attitude (altitude) adjustment it fired right up in smart military fashion.

Glen also shared this tidbit from earlier in the day. A girl of about 8 years had climbed down inside the Ferret and as she emerged, she turned toward the rear where its' communications antennae are mounted. Upon spotting them she said, "Look mom, WiFi". Priceless.

Thank-you, to everyone who braved the early morning rain to bring cars, and also to those who arrived later. Your participation made the day.

In This Issue

- **Events**
- **Just a Chuckle**
- **Auto Jumble**

www.lambscarclub.com

St. George's Day 2013

A few Pics from the Day



RUN TO THE SUN – SUN PEAKS CLASSIC CARS

Bring your family and friends to 'Run to the Sun: Classic Car Gathering', enjoy live music and view a collection of classic cars, including MG, Jaguar, Ferrari, Mercedes-Benz, and so many more - there'll be much to admire for the car connoisseur.

A full weekend event with receptions, Show 'n' Shine, wine & tapas, and so much more – including the fun awards at main stage!

Show 'n' Shine will take place in the Sun Peaks village from 11:00am to 3:00pm on Saturday September 21, with a bouncy castle and face painting for the kids! Cars will be on display along the village stroll.

Registration is open to all Classic Car groups and owners but space is limited – don't hesitate to register before space sells out.

SINGLE CAR REGISTRATION FEE: \$15 + GST (pre-registration required)

Show 'n' Shine registrants will receive a Dash Plaque, lunch voucher for burger and beer at Masas's Bar & Grill, and will be considered in the judging.

WEEKEND SCHEDULE FOR REGISTRANTS:

Friday, September 20

> Onsite Check-in, 2:00pm to 6:00pm

> Welcome Meet & Greet, 4:00pm to 11:00pm

Hosted by Fraser Valley British Motor Club, Morrissey's Public House

Contact: Larry Payeur, larrypayeur@hotmail.com

Saturday, September 21

> Onsite Check-in, 7:00am to 9:00am

> Show 'n' Shine, 11:00am to 3:00pm

> Judging at the Main Stage, 3:15pm

FATHER'S DAY Open House

Join us with your Car for Father's Day at the Canadian Museum of Flight . We will have a mini show for all attending the Museum./ A great Photo op and a chance to show British pride at the museum

Call Victor for Details



MEGUIAR'S part deux

The 40 people in attendance May 8th for the MEGUIAR'S polishing clinic were enlightened and educated by the information and demonstrations. Moving through the crowd during the evening the words consistently heard were: "I didn't know that before", and "I learned a lot", or "Now I'm not afraid to use the power polisher or", and a few of us declared we now had the understanding and confidence to use a clay bar.

Participants were encouraged to be 'hands-on' during evening. Those who used the power polishers and the clay bar for the first time last night were wowed by their new understanding. Gary from MEGUIAR'S told the audience, "It's not rocket science", but when we are faced with the potential of ruining the paint on our 'baby', it becomes a daunting task to select and use the correct tools.

Our LAMB club will definitely want to do another session, perhaps including interior detailing or engines and wheels. Whatever it is, we will once again have an enthusiastic following.

Our thanks to Foreman's Auto Service and Gary Wedemeyer from MEGUIAR'S for their outstanding efforts to make this a success.

Tips and Takes

By Michael Grant
Moss Motors



Recommended Oil Usage

For classic cars without a catalytic converter: Use non-API certified oil Viscosity 20W-50 ZDDP at 0.12 percent or 1,200 PPM

For vehicles driven frequently: Use oil formulated for classic cars (Moss 220-810, 220-815) Contains rust and corrosion inhibitors Viscosity 20W-50 ZDDP at 0.12 percent or 1,200 PPM

For classics driven less frequently: Use API SM oil Viscosity 20W-50 ZDDP at 0.08 or 800 PPM Add 4-oz. ZDDPlus to 4 quarts to get 0.14 to 0.15 percent ZDDP Add 4-oz. ZDDPlus to 5 quarts to get 0.11 to 0.12 percent ZDDP

Note: A more detailed version of this article with tech tips is available at britishmotoring.net.

Which oil should I use in my classic car?

It's incredibly important to ask this question. Why? The reduced level of zinc dialkyldithiophosphate (known as ZDDP, ZDP or ZnDTP) in modern motor oil has been linked to increasing numbers of tappet and camshaft failures in vintage engines.

What Exactly Is the Problem?

The cam/tappet failure problems often begin with a freshly rebuilt engine that starts making expensive-sounding noises. Inspection might reveal that the bottom of one or more tappets is gone. Instead of a smooth, machined surface, the face of the tappet will look like the surface of the moon. If the problem is the camshaft, it will exhibit one or more worn lobes.

Just one failed tappet or cam lobe will create a problem, as the damage results from direct metal-to-metal contact. With metal debris in the sump, there is no choice but to tear down and rebuild the engine. Choosing an assembly lube and motor oil is critical in preventing this metal-to-metal contact.

Corrosion, which occurs over time when classics are not driven, is another serious issue. Normal motor oil is designed to lubricate, not to coat or protect metal surfaces from corrosion. All oil absorbs moisture from the atmosphere. Running the engine will eliminate this moisture, but leaving a car to sit for extended periods of time will lead to corrosion. Using an oil product that forms a clinging protective film on the exposed metal parts can minimize this problem. If the oil contains special corrosion inhibitors, all the better.

Repair shops specializing in British cars have been dealing with these issues for years, and most have developed a combination of parts, machine work, engine prep and lubricants to reduce these problems. Many shops cite assembly lube, oil and the amount of ZDDP in the oil as major concerns.

What Is ZDDP?

Zinc dialkyldithiophosphate is an oil supplement that has served as the primary extreme pressure (EP) ingredient in all quality motor oils for the past 70 years—until recently. What does it do? When exposed to heat and pressure, ZDDP forms a protective film on metal surfaces that prevents parts (cam lobes and tappets, for example) from making metal-to-metal contact.

Why Do I Suddenly Need ZDDP?

ZDDP has been phased out because it damages catalytic converters. Small amounts of zinc and phosphorus in the ZDDP coat the catalytic material, reducing the effective life of the converter. The ZDDP level in motor oil was reduced from 0.15 to 0.12 percent (1,500 to 1,200 PPM) in 1993, and further reduced from 0.08 to 0.06 percent (800 to 600 PPM) in API SM-grade oil in 2004. But is this level enough for an older engine, especially when it isn't run frequently? And is it enough to protect the cam and lifters in a freshly rebuilt older engine during the critical break-in period?

The experience of hundreds of professional engine rebuilders, cam manufacturers and restorers indicates the mandated ZDDP level is not enough. The Engine Builders Association concluded that 75 percent of reported cam/tappet failures were due to the reduction in ZDDP. Association Technical Bulletin 2333R (November 2007) says current engine oils used by engine manufacturers in new car production should not be used for initial flat tappet/camshaft break-in. It recommends adding additional zinc for camshaft and lifter break-in. Most cam manufacturers also have specific instructions regarding assembly lube and break-in oil, citing cam/ tappet failures.

Send us the Tips so we can all benefit from your expertise,
findings and knowledge

www.lambscarclub.com

Auto Jumble Set for Fall 2013



Gentlemen...and Ladies.... Start your cleaning!
We have booked September 29th for next Auto Jumble.
The Place Sullivan Hall at 63 ave and 152 Street in Surrey..

Details will be available soon on the website
www.lambscarclub.com.

Contact John Walkden at lambmc@telus.net for details

Upcoming Events

Saturday, May 18, 2013 Vancouver ABFM
http://www.westerndriver.com/?page_id=5288

Monday May 20, Fort Langley Days Parade – Contact Carole

May 25th – Aldergrove Parade – Call Carole B

Friday/Saturday May 24 and 25, 2013 - Coastal Swap Meet - Abbotsford - All Cars

Saturday June 15 – Czorny Family Day Show – Contact Carole

Saturday June 22 Highland Games
– contact Simon at simonscott43@me.com

Saturday July 6, 2013 – CFB Esquimalt Chrome and Wheels Show

Sunday July 21, 2013 - Minter Gardens Classic Car Show - Chilliwack BC.

Friday July 19- Aldergrove days Show and Shine – Aldergrove High School

Regalia

LAMB Regalia for Sale

Club Jacket Women's size Large Only ; \$45.00

LAMB Grill Badges \$30.00

St. George's Show T-Shirts \$5.00

Contact : John Walkden - lambmc.telus.net



LANGLEY AREA MOSTLY BRITISH MOTORING CLUB

President : Lyle Pona
lpona@shaw.ca

Vice President – David Smith
dnmsmith47@yahoo.ca

Past President – Michael Boyle
michaelboyle@shaw.ca

Secretary:
Denis Copley mrdee@telus.net

Treasurer John Walkden
lambmc@telus.net

Membership- Victor Russell
vtruss59@hotmail.com

Website: Martin Ross
mrmartinross@gmail.com

Appointed positions will be:
Newsletter Editor Marty Ross
Scrapbook/Historian John Walkden
Events The Executive
Regalia John Walkden

Club Website: www.lambscarclub.com
Club email
address: lambmc@telus.net

The club, nor its members take no
responsibility for inaccuracies ,
errors and omissions in this
publication.

Fall 2013
EDITION

SPOKE' N WORD



Run to the Sun-Good Show



LAMB'S 2nd Annual Auto Jumble

Over 130 braved the wet weather and attended our second Auto Jumble at Sullivan Hall in Surrey. 18 vendors had tables in the hall and one brave soul outside in the parking lot. According to the vendors, and from the club viewpoint the day was very successful. Our thanks to John and Betty Walkden for their organization, and to the other members who helped with set-up, tear-down, and in the kitchen, the club booth and at the door.

Plus we added 6 new members at the event.

Next year's date has been set for Sunday, September 28, same place same time



LAMBS Flock to Cruise-In

12 Lamb cars appeared at Douglas Park for the Langley Cruise In this year. The show was a great success with lots of attention to our British cars. In attendance were Alex Green and his London Taxi, Chris Bennett and his Jaguar XK150, Kerry Turner with his 1950 MGTD and Morris Traveler, John Walkden and the Rover, Carole and her XJ-S Jaguar, Marty Ross and the Morris Minor 1000 and cut away engine, Lyle Pona and the MGTD, Fred VanAggelen and his Morris Oxford and Denis Copley and his Austin Healey.

We got lots of great press as well with the Langley Advance promoting the club in an article on the Wednesday prior to the show.

Not BAAAAHD

Hougen Park British Car Picnic

Another great day in the valley with the Fraser Valley British Car club sponsoring this picnic in the park event at Hougen park. Over 10 Lamb cars were in attendance along with 70 or so Fraser Valley and other British cars.

LAMB supports Simpson Manor

Simpson Manor is a 96 resident, 84 room long term care home in Fort Langley. In support of one our members, the club had 18 cars at the manor for a mini show on September 11, 2013. The show was appreciated by all who attended both from the facility and those driving by. "Our community is important to us and that is why we so pleased to be able to do this type of event" stated Lyle Pona, President of the LAMB Motoring Club.



TECH TIP S

POLARITY CHANGE by Dave DuBois <http://homepages.donobi.net/sufuelpumps/>

To change the polarity of any positive ground vehicle to negative ground, proceed as follows:

1. Reverse the leads to the battery such that the negative terminal is connected to ground.
2. Reverse the primary leads to the ignition coil (i.e. the leads to the terminals marked either + and - or SW and CB).
3. If the vehicle is equipped with an ammeter reverse the leads to the ammeter.
4. In the case of the 65 - 67 MGB it is necessary to reverse the pickup leads to the tachometer and have the tachometer rewired for negative ground. To reverse the pickup leads, look for the white wire that loops through the pickup adapter on the back of the tachometer (the white wire comes out of the harness, loops through the adapter and goes back into the harness). Mark the incoming wire in two places, about an inch apart with some colored tape; mark the outgoing wire the same way with some different colored tape. Cut both wires between the points marked by the tape, strip and splice the wires to the wires with opposite colored tape. Insulate the splices with tape or shrink sleeving.

Note: The tachometer will have to be changed internally to operate in a negative ground environment as follows: To reverse the power wire and earth wire inside the unit, it is necessary to remove the chrome ring, the glass face and the glare shroud. The chrome ring is usually removed with great difficulty by prying the tabs with a small screwdriver, then rotating until the tabs can fit through the slots in the case. Remove the two screws on the back of the unit that hold the internals to the case (not the two whose heads fit in holes in the case), and allow those internals to drop carefully into your hand. Don't bend the needle! The spade terminal is the power connection. Just next to this is the earth connection. A resistor is soldered to one of these connections, and a green wire to the other. Unsolder these ends of the green wire and the resistor from their current positions. Re-solder the green wire to where the resistor was connected, and the resistor to where the green wire was connected. Reassemble the unit after cleaning the glass.

5. If the fuel pump has been transistorized, if it is a late production pump with a diode installed, have it rewired for negative ground.
6. If there is any auxiliary equipment installed in the car (CB, Radio, Stereo, after market electronic tachometer, etc.), they will need to be replaced or, if they are a dual polarity unit, the power and ground leads will have to be switched.
7. Remove both leads from the generator. Connect a 12 gauge jumper wire to the field (small) terminal of the generator. Quickly touch the other end of the jumper wire to the terminal of the starter solenoid that has the battery cable coming to it two or three times (wire should be touched to the battery terminal just long enough to produce a spark). Disconnect the jumper wire from the generator and reconnect the original wires to their respective terminals.
8. At this point, the polarity (ground) has been changed and the car can be started.

An MG Midget pulled alongside a Rolls-Royce at a traffic light.

"Do you have a car phone?" its driver asked the guy in the Rolls. "Of course I do," replied the haughty deluxe-car driver.

"Well, do you have a fax machine?" The driver in the Rolls sighed. "I have that too."

"Then do you have a double bed in the back?" the Midget driver wanted to know. Ashen-faced, the Rolls driver sped off. That afternoon, he had a mechanic install a double bed in his auto.

A week later, the Rolls driver passes the same MG Midget, which is parked on the side of the road—back windows fogged up and steam pouring out. The arrogant driver pulls over, gets out of the Rolls and bangs on the Midget's back window until the driver sticks his head out. "I want you to know that I had a double bed installed," brags the Rolls driver. The Midget driver is unimpressed. "You got me out of the shower to tell me that?"

Panther Precision Machine tour a "wheel good" show

Over 30 people attended a tour of Panther Precision Wheel facility on 130th Street in Surrey. Panther is an aluminum wheel repair and refinishing specialist and restores wheels for all kinds of vehicles including some British cars. Their work is very good and the manager Paul Levasseur showed us the shop and the complete process of taking a damaged wheel to perfectly shiny and straight. It was a great evening of knowledge and camaraderie



Ladner Car Show and Quilt Walk attracts lots of British cars this year

Where can you find over 400 cars and a custom quilt show.... beautiful downtown Ladner. This is one of the best shows of the year and while this year we had a spot of the wet stuff, the day was outstanding. John Walkden, Marty Ross, Dave Baron and Kerry Turner were on hand to show off our club cars. We also had the Morris Minor flat head cut away engine on display. This was very popular with the dad's, showing how engines work to their children.

LANGLEY AREA MOSTLY BRITISH MOTORING CLUB

President : Lyle Pona
lpona@shaw.ca

Vice President – David Smith
dnmsmith47@yahoo.ca

Past President – Michael Boyle
michaelboyle@shaw.ca

Secretary:
Denis Copley mrdee@telus.net

Treasurer John Walkden
lambmc@telus.net

Membership- Victor Russell
vtruss59@hotmail.com

Website: Martin Ross
mrmartinross@gmail.com

Appointed positions will be:
Newsletter Editor Marty Ross
Scrapbook/Historian John Walkden
Events The Executive
Regalia John Walkden

Club Website: www.lambscarclub.com
Club email
address: lambmc@telus.net

The club, nor its members take no responsibility for inaccuracies , errors and omissions in this publication.

Check the website for updates and contact information

2013

SPOKE' N WORD



Langley Area Mostly British Motoring Club



Everyone loves a parade and that includes the councillors of Langley City and Township. They especially love the LAMB cars and this year we escorted the council in 3 parades in May and June.

ALL British Field Meet 2013

Well it tried hard to rain on the event again at VanDuesen Gardens in Vancouver for the ABFM 2013. However the sun broke through and all was well at the show with over 600 cars and other vehicles on display. This year show featured the 100 year anniversary of the Healy and 100 years of manufacturing at the Morris Cowley plant in Oxford, home to the Morris, Mini, Rover and the new BMW Mini.

LAMB was well represented, not only at the show, but on the podium as we had winners and runner ups in several classes. Prize winners included: Jim and Irma Cave (Met and Port-a-fold Trailer), Jim Bond (lotus) John Walkden (Rover), Trish and Adrian (Triumph), Doreen and Ian Newby, (Ferret) Barry Lafbery (Rover), Carole Borgens (Jaguar).

Not bad for a little club in Langley BC.





Highland Games a Real Fling

This year's Highland Games in Coquitlam on June 22 was a great success. The weather cooperated and the day was perfect for British motoring and Scottish pride.

Over 20 motoring vehicles were present at the showing including some nice jaguars, Triumphs, Morris(s) and Double Decker bus and taxi from the Newby's collection. Carole Borgens, Marty Ross, Mal Wood and Bill Grant showed the colours of the club.

With the sad passing of Mike Powley earlier this year, Simon Scott organized the event and everything went off without a hitch. (Mike would be proud). There were lots of exhibits, competitions and refreshments including a whiskey tasting and information tent.

Mark your calendars for 2104 for June 21 Games. As Simon commented it is the "best free parking spot you can have at the games"



Canadian Museum of Flight Show Fathers Day Open House and Car show

The Father's Days celebration was in full flight with 17 British cars on display at the Canadian Museum of Flight at the Langley Airport. The museum held their annual open house highlighted with Lamb cars and other club vehicles in front of the main entrance.

This could be our second big event of the year as everyone enjoyed the day and with a little promotion we could increase traffic and cars at the show.



Dazzle Your Senses

Minter 's last show

Brian Minter, owner operator of Minter Gardens in Agassiz announced in late June that the Minter gardens site will be closing permanently in October 2013. the gardens has been the site of the annual classic car show for the past 11 years.

"The show is a highlight of the year and caps off the car show season in the valley" stated John Walkden. it will be missed both by LAMB and the Fraser Valley Clubs.

11th Classic Car Show
Sunday July 21, 9am-4pm
Petal Pushers meet Pedal Pushers at the 11th Annual Classic Car Show! Together with the Fraser Valley British Motor Club, we welcome guests to the final car show at Minter Gardens.
Contact - c-park@telus.net

Specialty Vehicle Association of BC



At the June general meeting, Kent Roberts presented information about the Specialty Vehicle Association of BC, of which LAMB is a member. The SVABC is dedicated to work with individuals, clubs and associations to preserve the vintage and collector type motor vehicle and motor cycle hobby.

Benefits of Membership

- Retain & protect your rights & rates already negotiated under the Collector Plate Program
 - Your voice with Gov't Agencies
 - Advice/assistance in obtaining your Collector Plate
 - Interpretation of Inspection Standards
 - Assistance in Registering your favourite ride
 - Focal point for dealing with the Gov't on matters that influence the hobby
 - Security
 - Membership is directly proportional to the amount of negotiation power the organization has when dealing with ICBC and other Government Depts. Without membership there is no voice. Clubs from many areas of the province are members.
- We encourage all members to consider adding their membership to their list and create a voice for our hobby in BC. Membership is \$5.00 annually.
- For more information see their website at <http://www.sva.bc.ca/>

FOR SALE?

Don't Forget to list your vehicles and parts on our website. It's Free and connects you to lots of British car fans.

www.lambscarclub.com

Parkinson Show at A&W In Surrey

July 7th a fund raising Show and Shine s held at the A&W on King George near 73rd Avenue in Surrey. Over 100 cars were in attendance for the all day event. Lyle Pona and his wife Diane showed their 1965 Mustang Convertible while Marty Ross had the faithful old Morris Minor to show the hot rodders how cars were made to look.

(Hmm maybe a chance to add some power and get more than 42 HP)

Another great event for a good cause.



Czorny Car Display and BBQ Well Appreciated

On June 15 the LAMB group and a few other clubs had a small show at the Czorny Alzheimer Center in Surrey for their patients and families . In all 10 cars displayed at the facility. The day was highlighted by a Hot dog BBQ put on by the center. The staff decorated the parking area with flags and streamers.

A great day for a good cause

British car plant clocks up 100 years of production

—Russell Campbell Classic Motoring Magazine Mar 2013



One of the country's most famous car manufacturing sites will celebrate 100 years of car production on 28 March. That date marks 100 years to the day when the first Bull nose Morris Oxford rolled off the production line a few hundred meters from where the modern factory stands now building BMW's MINI.



In the past century, the site has produced cars for MG, Wolseley, Riley, Austin, Austin-Healey, Mini, Triumph and Rover, plus models such as the Mini, Morris Minor and Austin-Healey Sprite.



The plant has had eight custodians, starting with William Morris who passed ownership to his company Morris Motors, which then merged with Austin to form the British Motor Corporation.

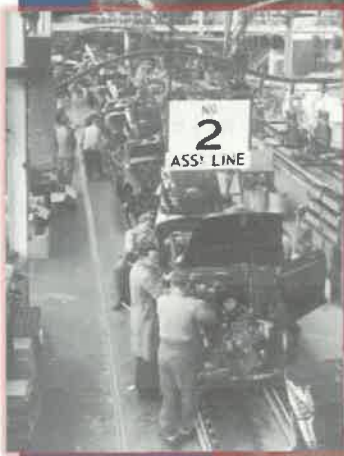

In 1967, BMC became British Motor Holdings after merging with Jaguar and, a year later, the British Leyland Motor Corporation, after joining forces with the Leyland Truck Company.

Nationalisation followed in 1974 with the company being christened the Rover Group, before BMW took over the group and the site.

Aside from building cars, during wartime the grounds also produced Tiger Moths and carried out 80,000 repairs on Spitfires and Hurricanes.



Chinese Will Begin Building Formerly British MG Cars



In memoriam

It with heavy hearts that we announce the passing of Byron Taylor, a LAMB member for the past 2 years. Byron was diagnosed with cancer that took his life this June. Our thoughts go with the family. A celebration of life will be planned for later this summer.

Upcoming Events :

New Westminster Show and Shine- July 14

Minter Gardens Show July 21

Aldergrove Fair days - Car show - Friday July 29th

Cloverdale Show and Shine- August 10

Ladner Quilt and Car show - August 18

Langley Cruise in - September 9

Autojumble – September 29th - Sullivan Station

20/table. Car corral \$10/car. Contact John Walkden

Regalia



LAMB Regalia for Sale

Club Jacket Women's size Large Only ; \$45.00

LAMB Grill Badges \$30.00

St. George's Show T-Shirts \$5.00

Contact : John Walkden - lambmc.telus.net



LANGLEY AREA MOSTLY BRITISH MOTORING CLUB

President : Lyle Pona
lpona@shaw.ca

Vice President – David Smith
dnmsmith47@yahoo.ca

Past President – Michael Boyle
michaelboyle@shaw.ca

Secretary:
Denis Copley mrdee@telus.net

Treasurer John Walkden
lambmc@telus.net

Membership- Victor Russell
vtruss59@hotmail.com

Website: Martin Ross
mrmartinross@gmail.com

Appointed positions will be:
Newsletter Editor Marty Ross
Scrapbook/Historian John Walkden
Events The Executive
Regalia John Walkden

Club Website: www.lambscarclub.com
Club email
address: lambmc@telus.net

The club, nor its members take no responsibility for inaccuracies , errors and omissions in this publication.

October
2016
EDITION

SPOKE' N WORD



AUTO JUMBLE

Good Deals, Great Food, Lots of Fun

This year's Auto Jumble was a huge success. September 25th our 5th annual Auto Jumble (cool words for spare junk sale) was held at the Sullivan Hall in Surrey. The event drew over 160 buyers for the 18 tables and 3 trailers full of parts and antiques for homes and cars. By all accounts everyone enjoyed the day. Thanks to John and Betty, Gord and Marion and Keith for setting up the event and the various members who manned the kitchen and front desk..

Stave Lake tour a great day on the road

_____ cars participated in a drive and tour on Sunday September 18, 2016. The event organized by Gordon Rawlings met at in Langley at 9am and the group drove to the Stave Lake Power Plant for a tour. The tour was very good. The group then proceeded to Mission for Lunch and then to the Fox and Fiddle in Langley

The best part was that the Rain held off for the day.

Thanks Gord for your coordination and efforts .



Summer Barbeque

What a feast at Kelly MacPherson's in August. Both a feast of great British cars on display and the food. We owe Kelly and Lisa a great deal of thanks for hosting, and putting up with us, at their home in Langley.

Thank you very much



CRUISE-IN 2016

Once again a great turnout for this year's cruise in in Langley. 14 cars were on display for the general public. Once again we were located in Douglas Park giving the groups a great spot to display the cars.

Thanks to all the member who were there with and without their vehicles. Your support makes this event one our best of the year.



Cloverdale Railway Event

35 People attended the Fraser valley Historic Railway in Cloverdale in August! the event provided the group with a chnace to see where the trains are rebuilt, ride some cars, and take a trip on the train.

One of the members comment it was great day capped by a "chance to stop traffic on Hwy 19 and wave to everyone" Thanks John for organizing this for the club.

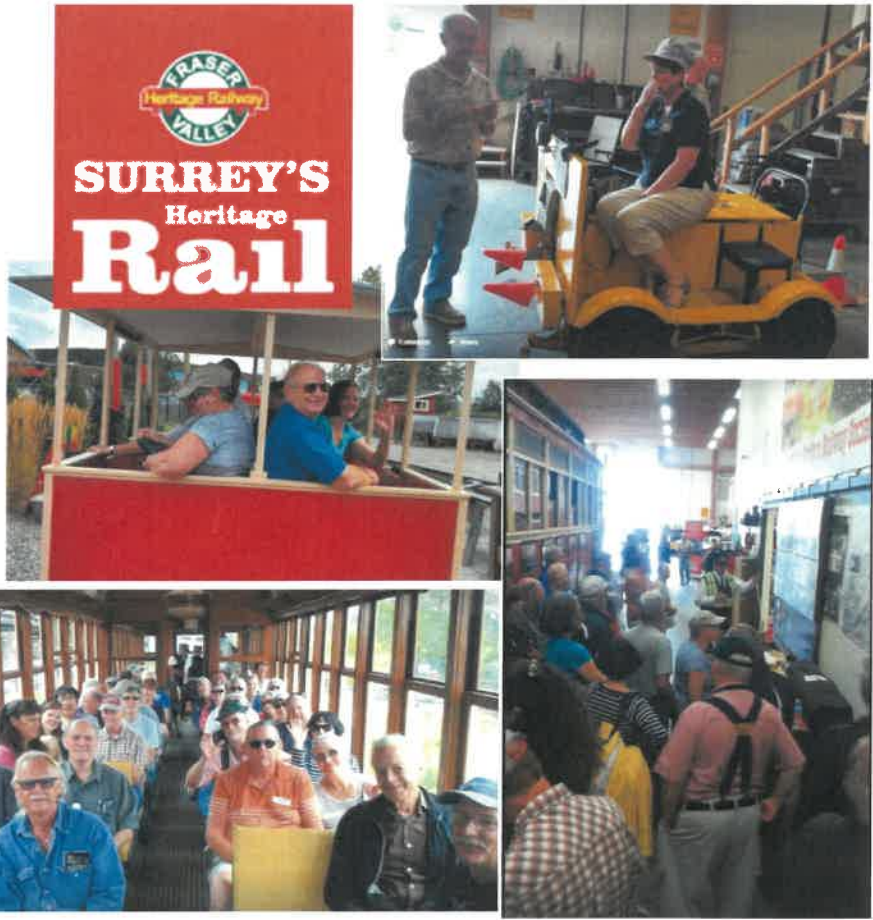

Welcome new members

We have 4 new members in September
 -Eddy Jalbert – 72 MJB and 76 MG Midget
 -Bruce Webster – 59 MGA
 -Christine Guay – 97 Jaguar VJ-6 Vanden Plas
 -Lew Lewandowski – 77 MGB
 Welcome to everyone and we look forward to meeting you at the next meeting October

Cars For Sale on the website



1998 Sportpack Rover Mini



1959 Morris Minor 1000 Convertible

Have parts to sell send the list to Marty Ross and we will include on the website and the Spoke'n' Word and we will publish on the website as well