

SECTION A-A
GRIP SCREW LOCATION

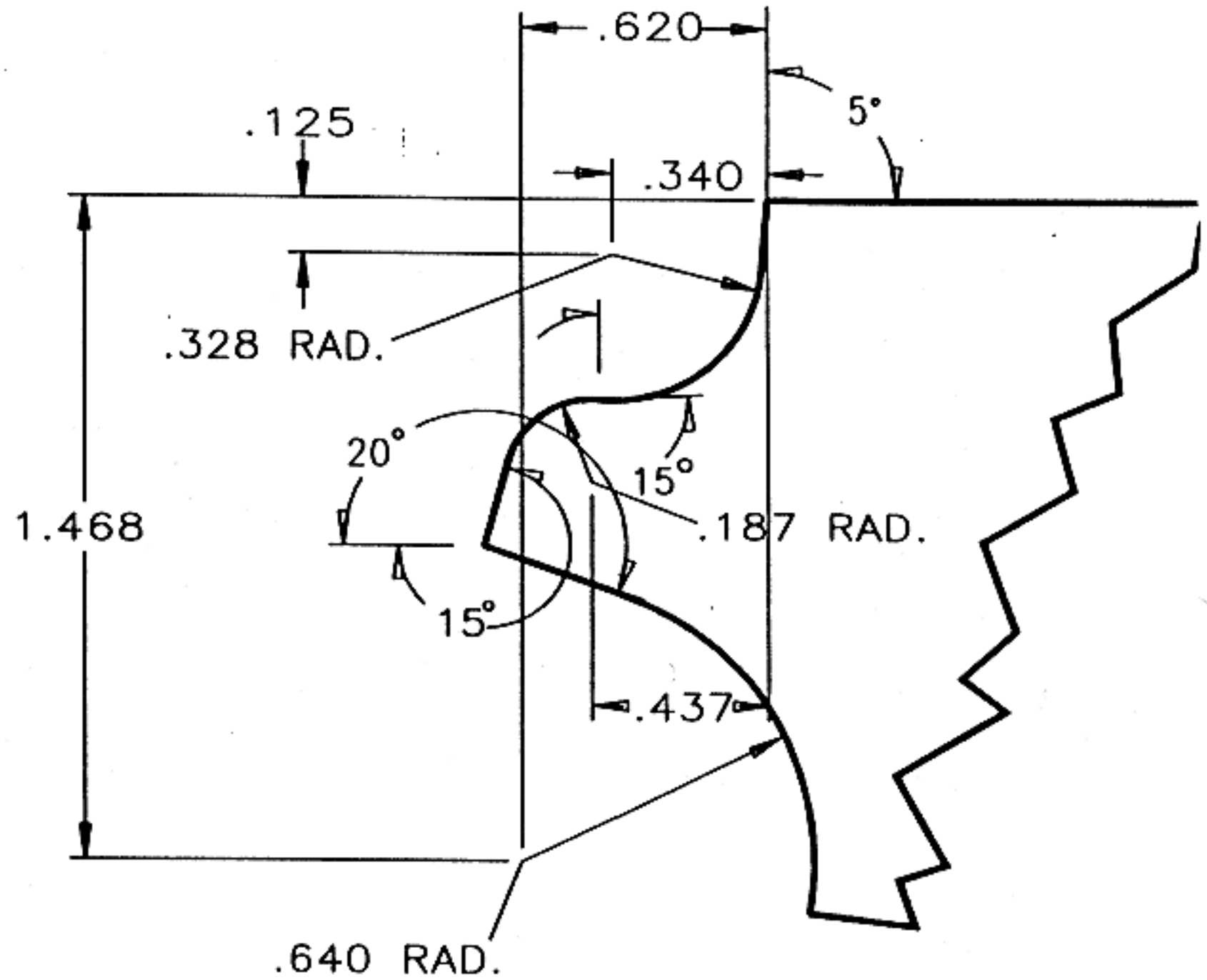

DETAIL #30

FRAME TANG

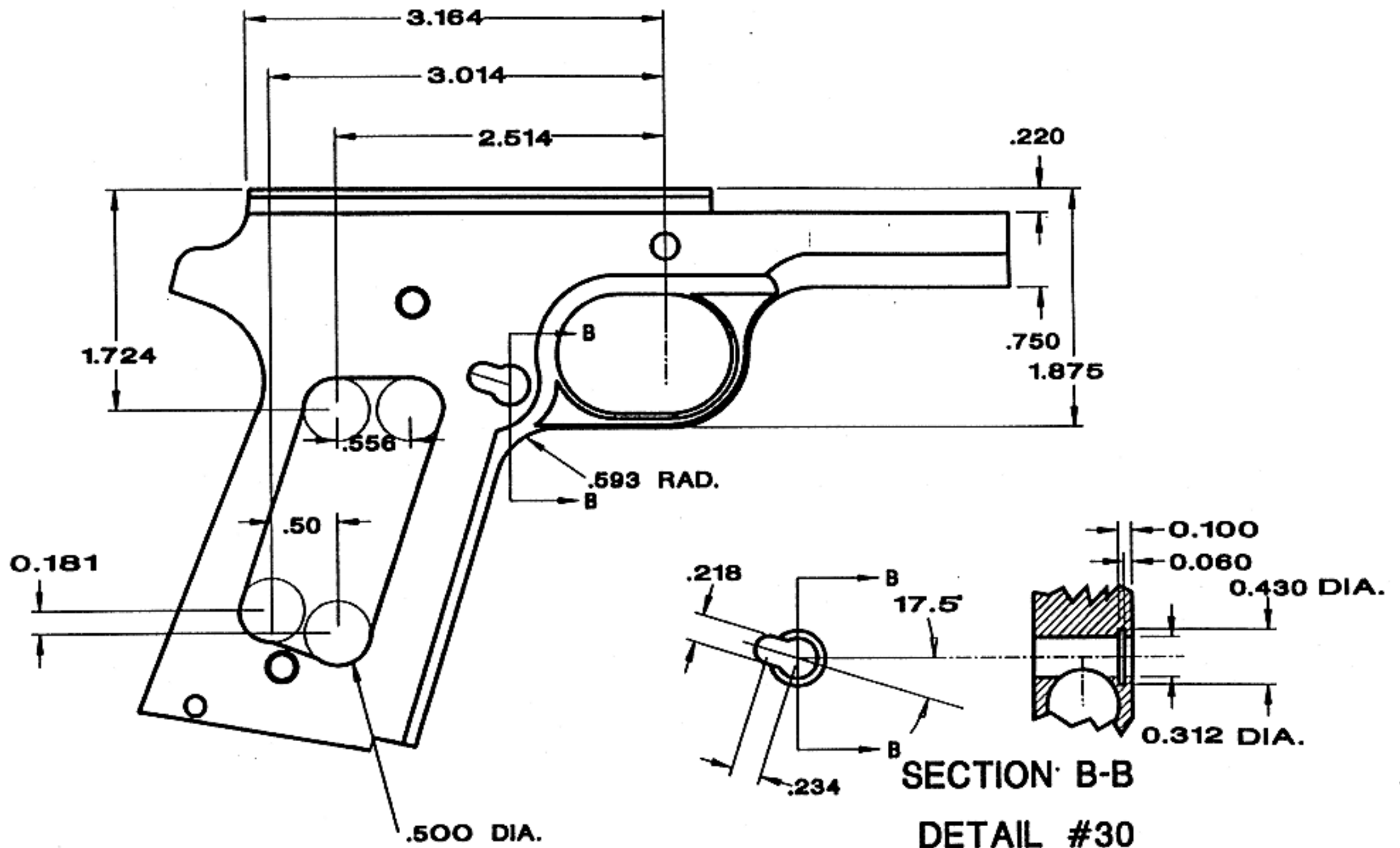

**RIGHT SIDE
 MAG. CATCH DETAIL**

FRONT END VIEW
FRAME
#30

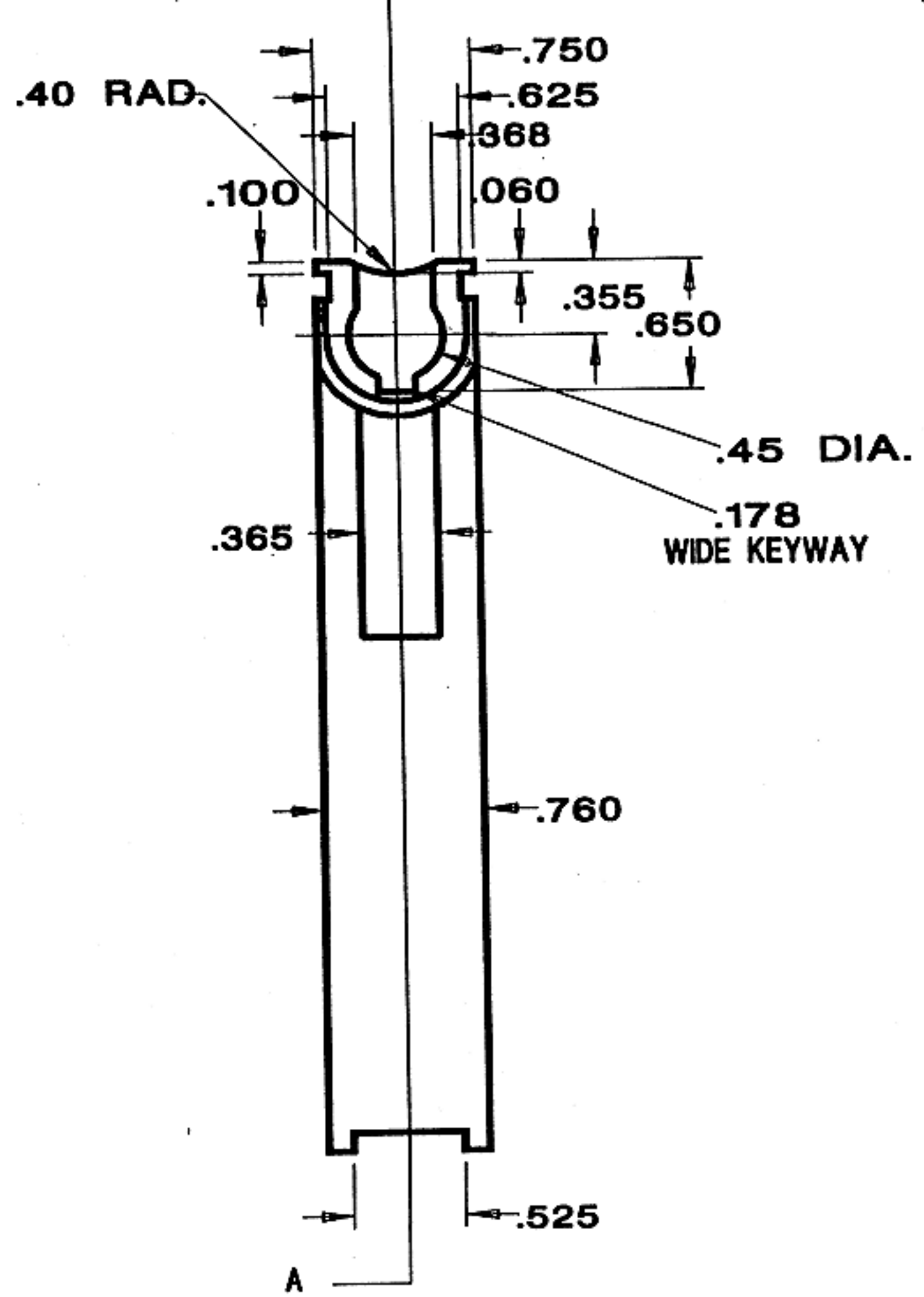

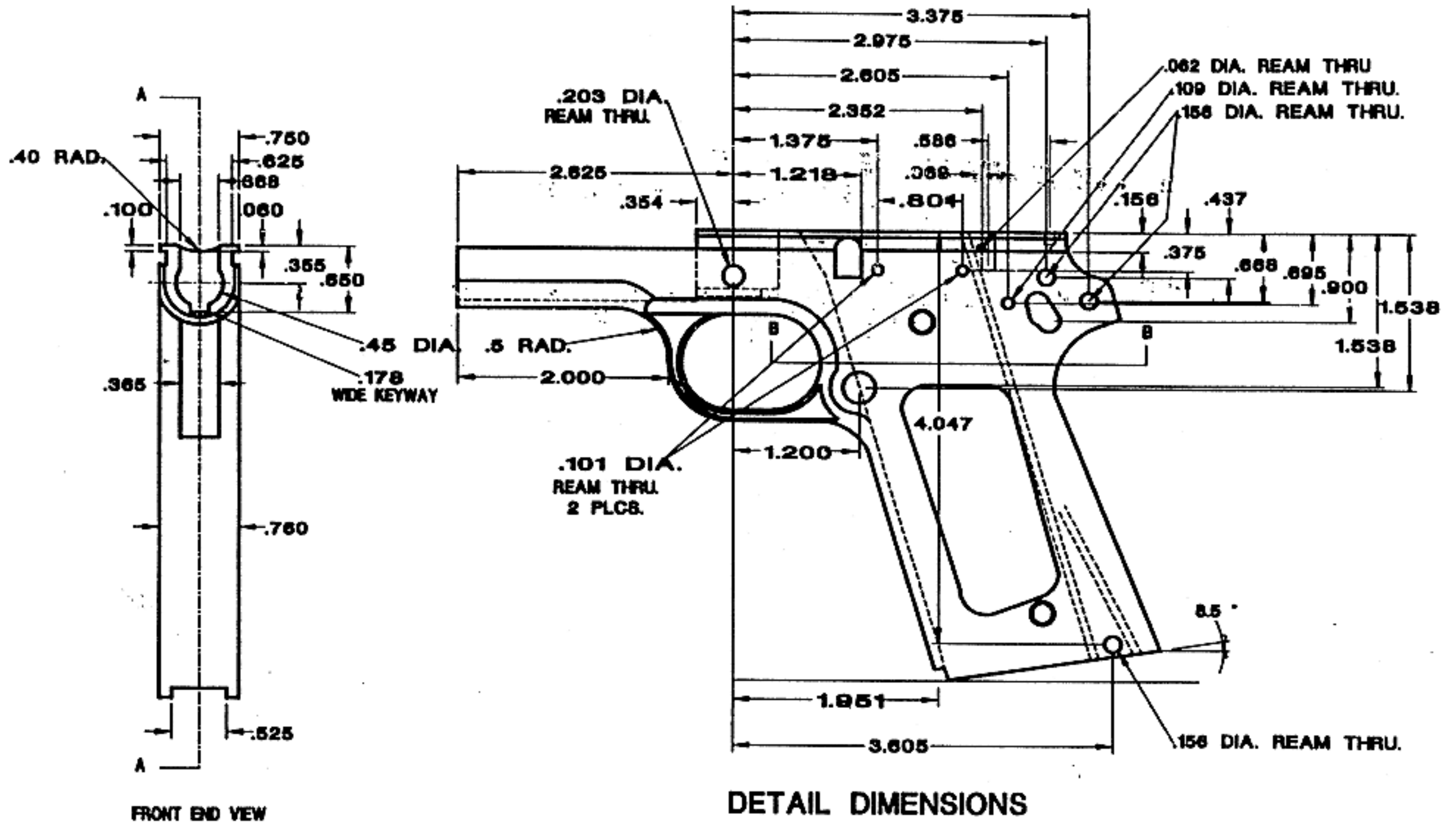

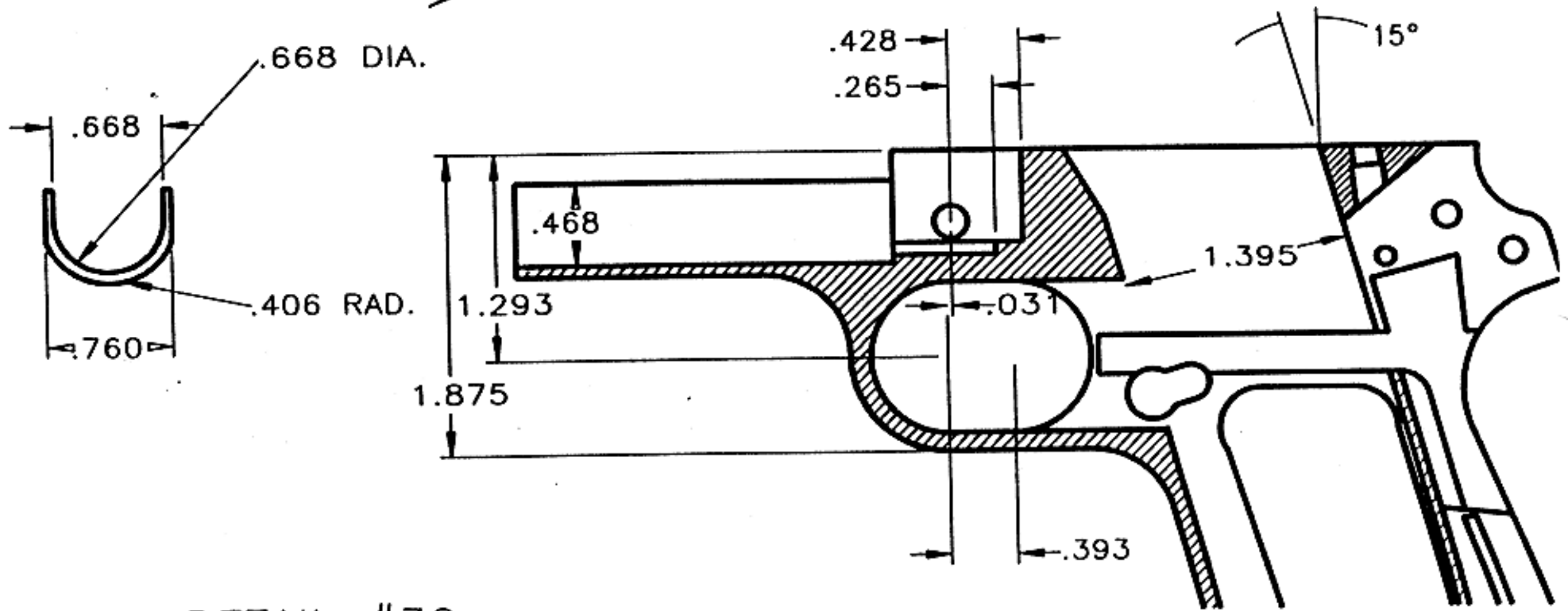
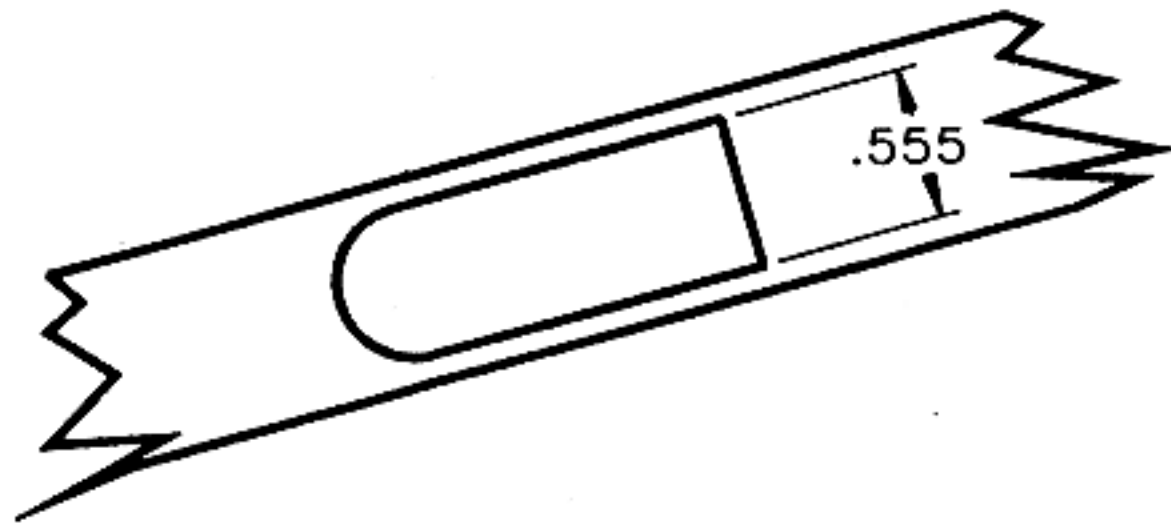

DETAIL #30

SECTION A-A
MAG. OPENING

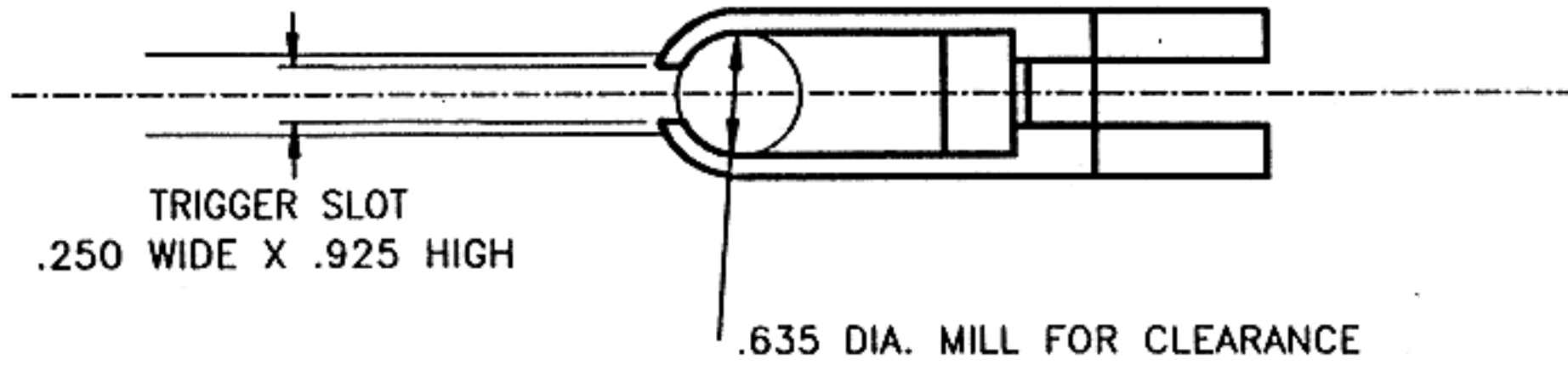

SECTION C-C
TRIGGER SECTION

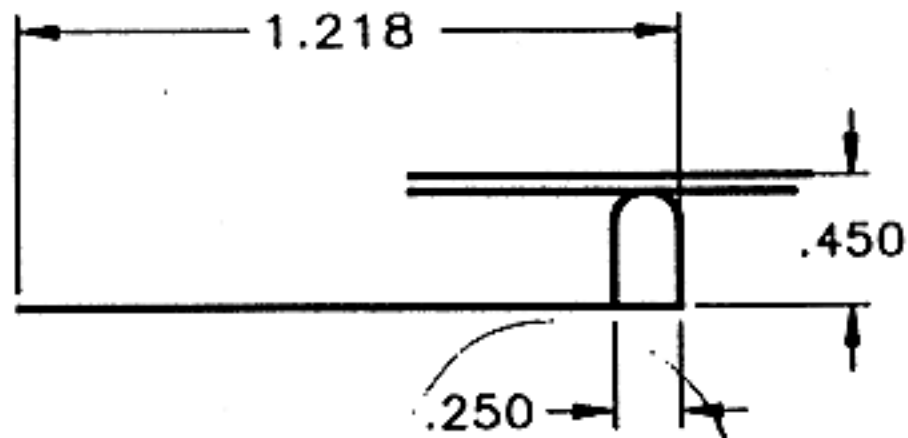

SLIDE STOP
SLOT DTEAIL

DETAIL #30

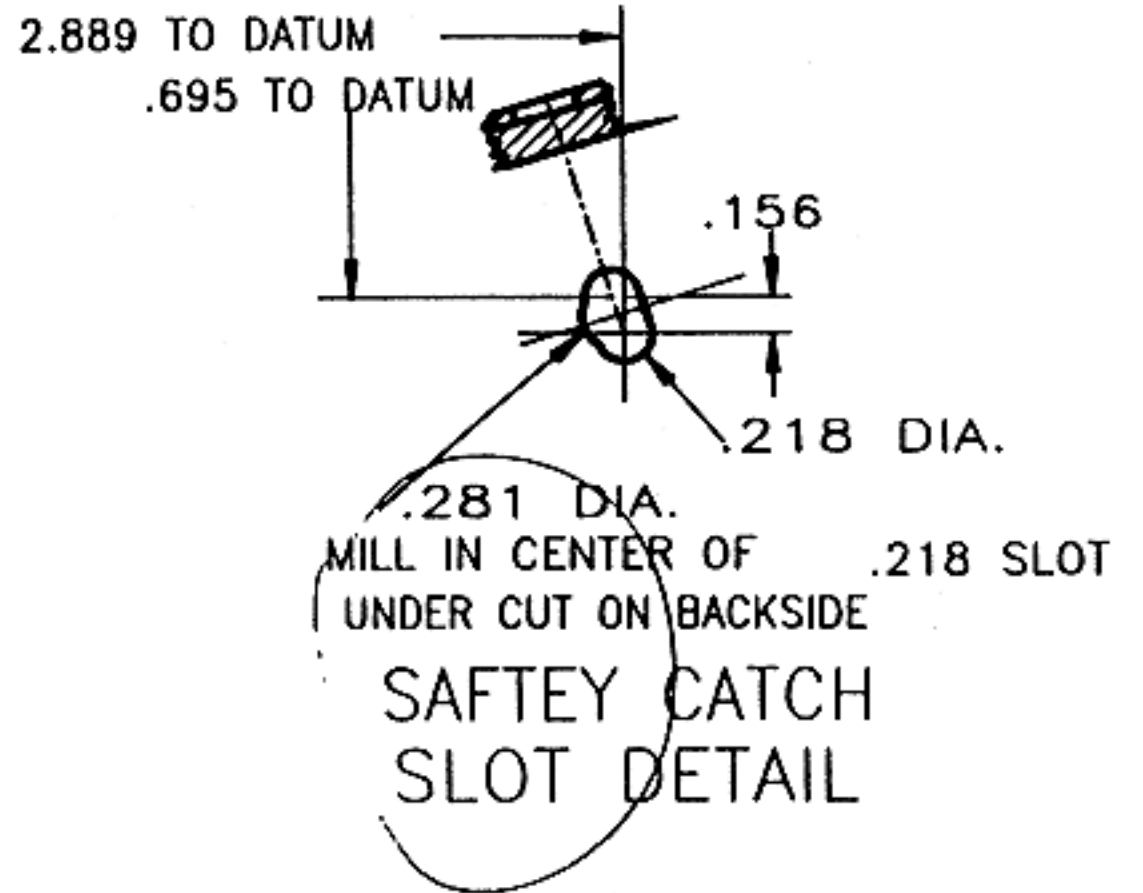

SECTION D-D

