

## **TABLE OF CONTENTS**

**1- scale print of THOMPSON SUB MACHINE GUN M1A1**

**1- scale print of MK 1 and MK 1\* LANCHESTER**

**1- scale print of MODEL 37 right and left side plates**

**1- scale print of UD-M42**

**PARTS SUPPLIERS ON LAST PAGE**

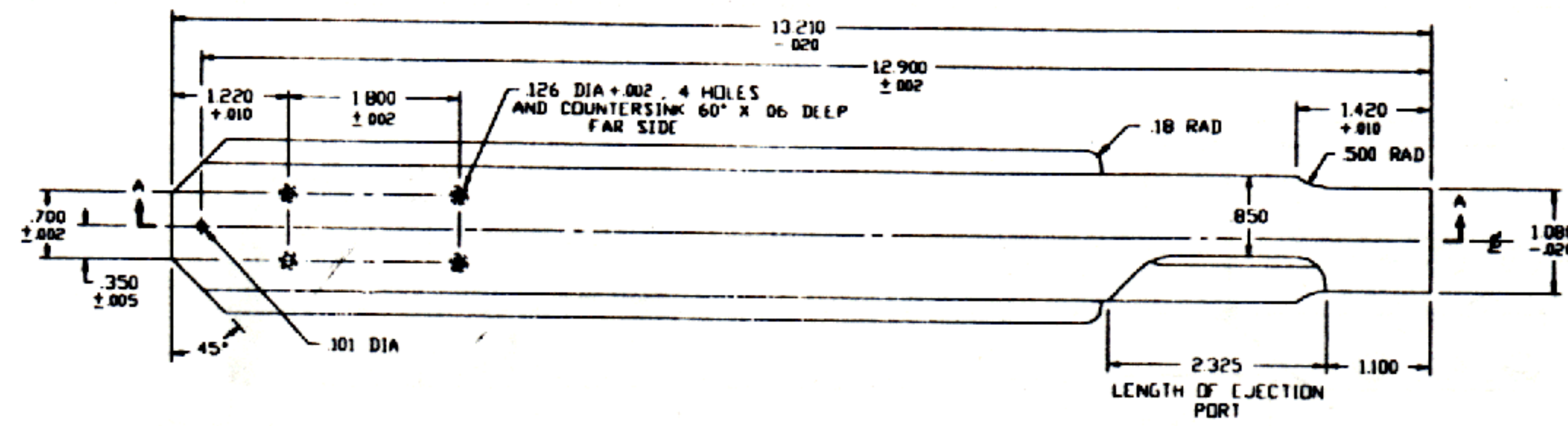

- NOTES**
1. MATERIAL - FS1340, FS2300 (FED SPEC QQ-S-624)
  2. FINISH - TYPE II CLASS A (SPEC USA S7-0-2)
  3. HARDNESS - ROCKWELL A615-70.5
  4. HEAT TREATMENT - HEAT 1350° LEAD POWDER  
CN IN NOTCHES, COOL  
REHEAT 1350° 1.5 MIN  
OIL QUENCH, DRAW 930°

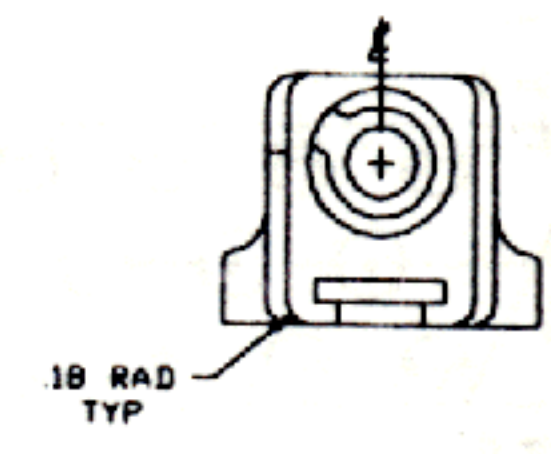
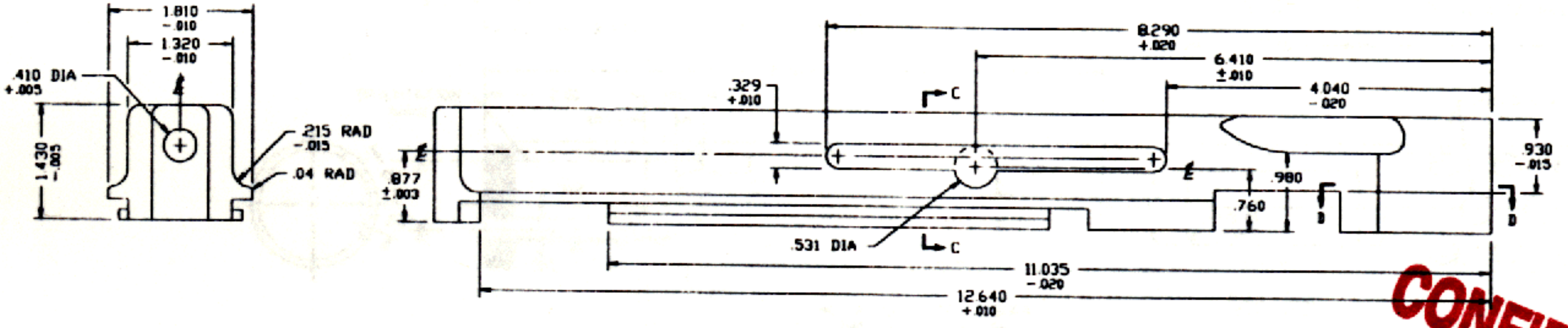

**CONFIDENTIAL**

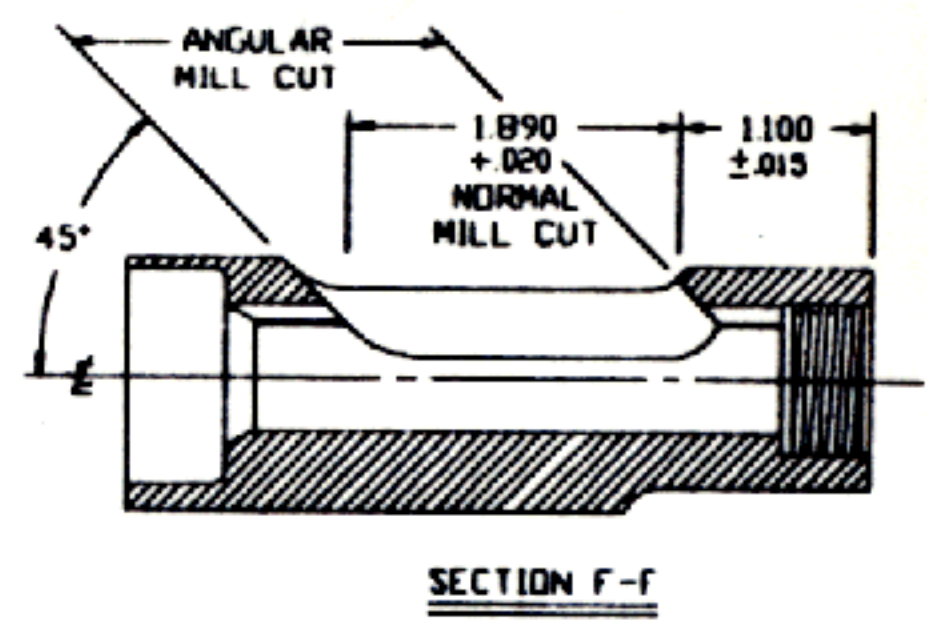
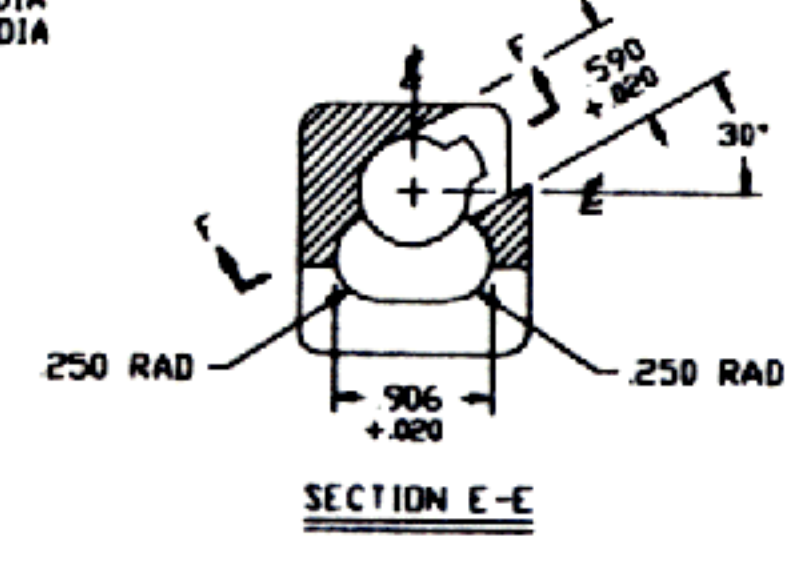
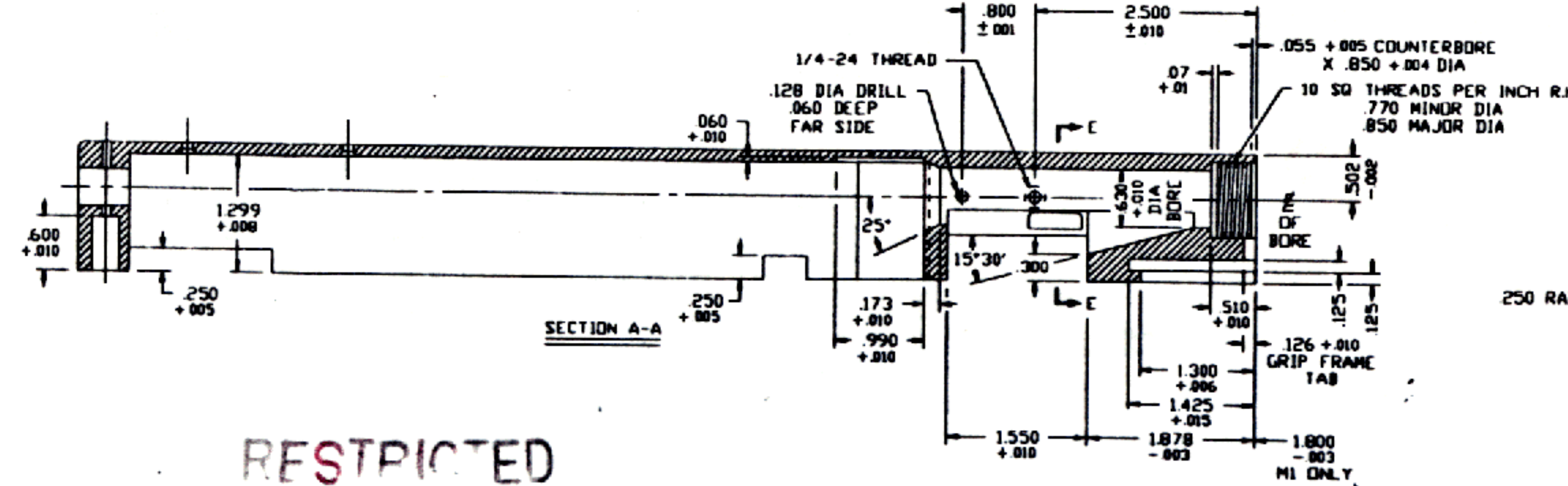
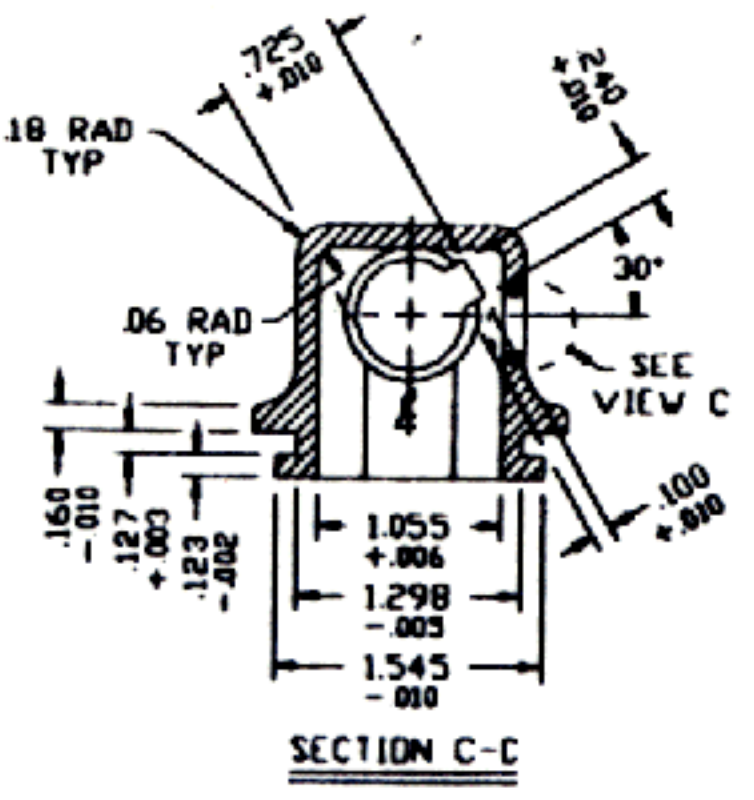
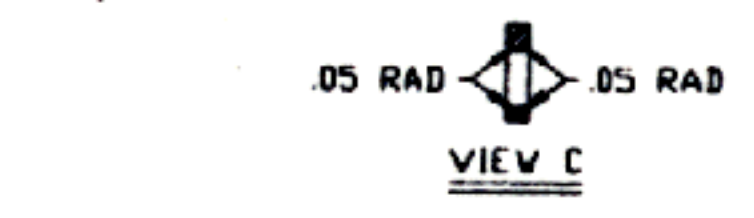
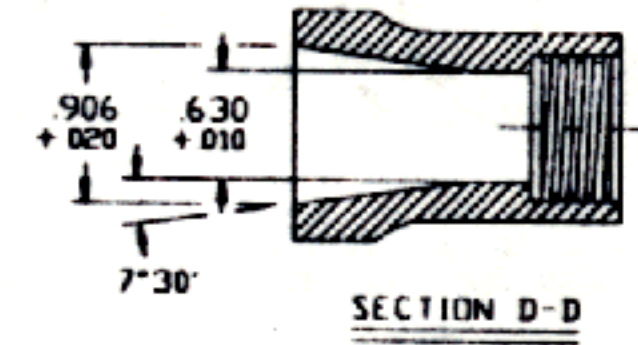
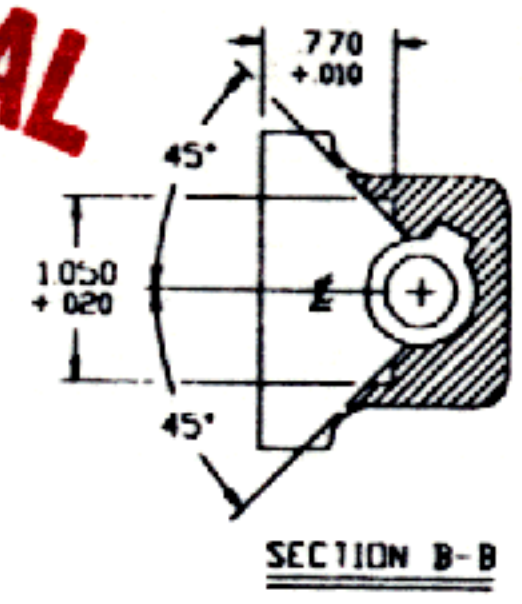
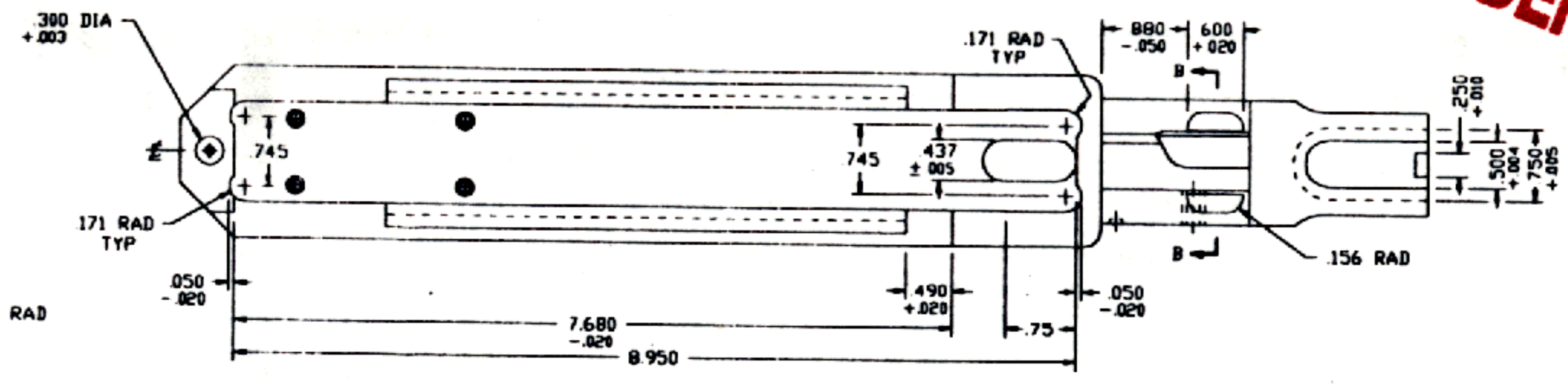

**RESTRICTED**

SCALE: FULL	MATERIAL: SEE NOTE 1	CHK	TOLERANCES
DWN	FINISH: SEE NOTE 2	DATE	DEC 1941
TITLE: THOMPSON SUBMACHINE GUN MODEL M1A1	REV	NO	DEC 1941

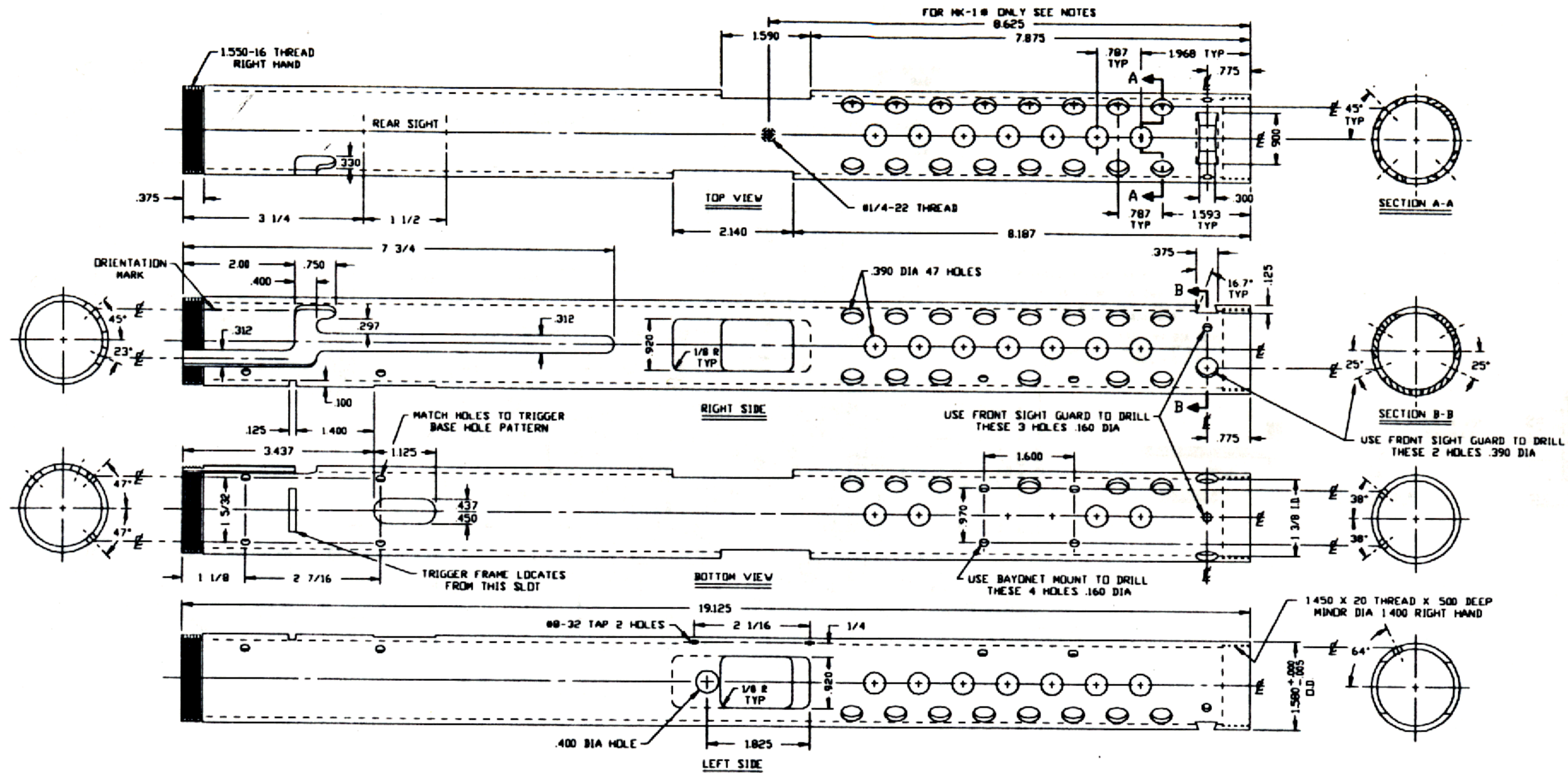

**GENERAL NOTES AND SUGGESTIONS**

1. TURN O.D. AND THREAD BOTH ENDS FIRST.
2. MARK 1 & IS THE LATER MODEL, FULL AUTO, AND HAS 1/4-22 SCREW IN TOP OF MAGAZINE HOUSING THAT LOCKS BARREL IN PLACE. TAP THIS HOLE & MAGAZINE HOUSING 1/4-20 AND USE ORIGINAL SCREW OR MAKE ONE.
3. ALL 160 HOLES WERE ORIGINALLY RIVET HOLES. I DRILL THESE HOLES #29 (.136) AND TAP #8-32 USE #8-32 X 1/4 ROUND HEAD MACHINE SCREWS.
4. WITH END CAP IN PLACE TIGHT, BACKOFF 1/8 TURN AND MAKE A LINE-UP MARK ON BOTH PARTS. PLACE TUBE IN STOCK AND LOCK END CAP IN PLACE. SLIDE MAGAZINE HOUSING ON TUBE AND LOCATE IN STOCK AND INSTALL HINGE SCREW. SPOT DRILL THRU MAGAZINE HOUSING FOR 2 #8-32 SCREWS. DRILL #29 AND TAP #8-32 AND INSTALL 2 #8-32 SCREWS, THE ORIGINAL ONES FIT. THIS ESTABLISHES THE HOUSING TO THE END CAP. ALL OTHER HOLES ARE RELATIVE TO THE 2 PARTS.
5. LOCATE ALL OTHER HARDWARE BY SPOT DRILLING IN PLACE.
6. MAIN PORTS CAN BE SCRIBED WHILE HOUSING IS IN PLACE. EXTRACTION PORT SIZE IS CORRECT, BUT MAGAZINE HOUSING HOLE IS LARGER.
7. THESE DIMENSIONS WERE COMPILED FROM 3 LANCHESTER RECEIVERS.
8. FRONT SIGHT DOVETAIL IS NOT A STANDARD TAPER MACHINE A STRAIGHT SLOT AND TRIM FRONT SIGHT TO FIT AND SOLDER IN PLACE.
9. FINISH BLUE ALL STEEL PARTS. BRASS SHOULD BE NATURAL, NOT PAINTED.
10. BAYONET: ENFIELD P1907 LONG OR P1907/42.
11. MATERIAL: 1 5/8 O.D. X 1 3/8 I.D. DOM 1020 STEEL TUBE.

**CONFIDENTIAL**

RESTRICTED

SCALE	FULL	DRAWING	SEE NOTE 11	CRD		TOLERANCES
DATE		FINISH	SEE NOTE 9	DATE		DEC 2 PL ± .001
TITLE	MK-1 & MK-1 & LANCHESTER RECEIVER			REV.		DEC 3 PL ± .001
						ANGLES ± .5°

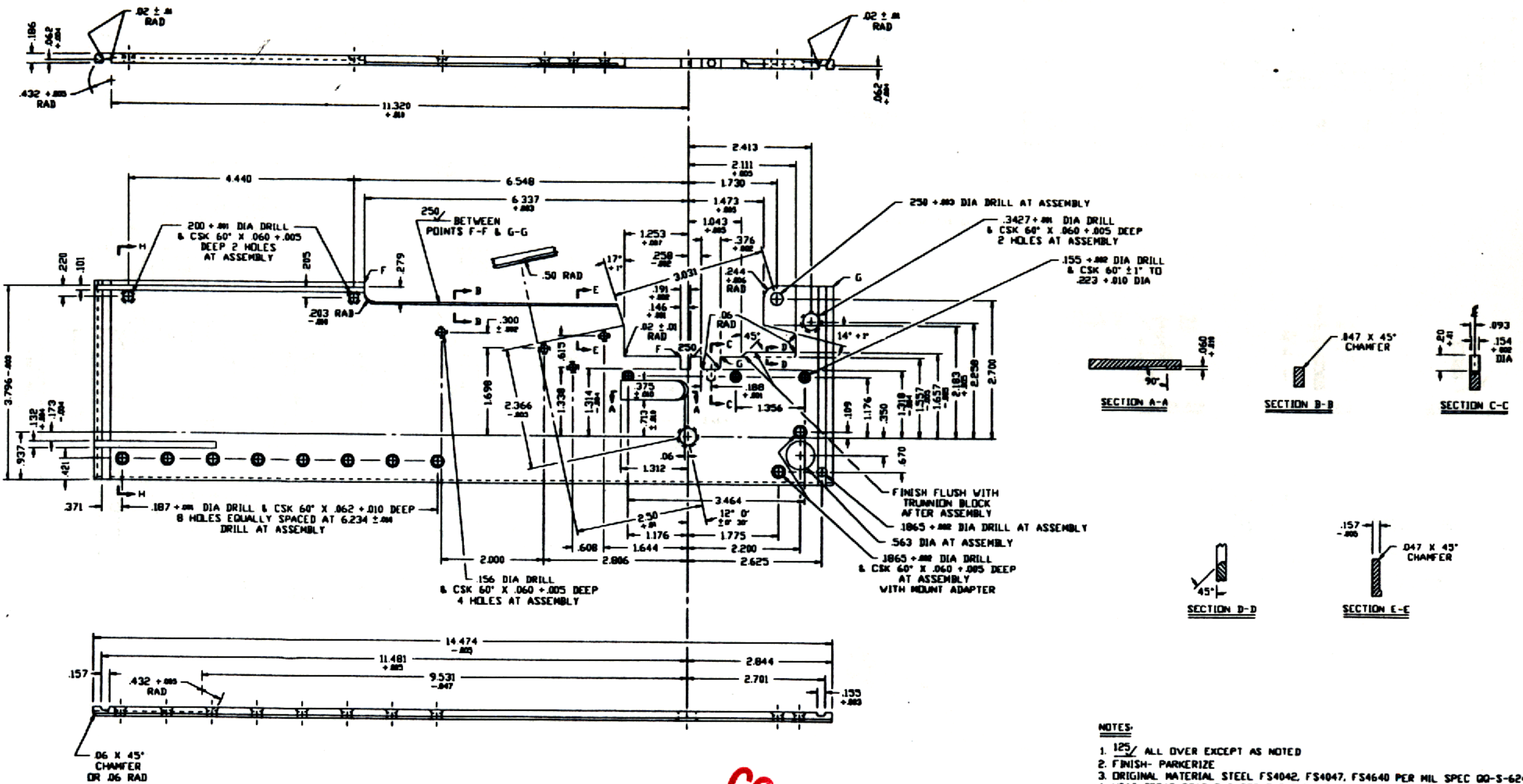

- NOTES:
1. 125/ ALL OVER EXCEPT AS NOTED
  2. FINISH- PARKERIZE
  3. ORIGINAL MATERIAL STEEL FS4042, FS4047, FS4640 PER MIL SPEC QQ-S-624
  4. HEAT TREAT REAR END FOR ONE INCH ROCKWELL "C" 43-49 ANNEL AROUND TWO HOLES.

CONFIDENTIAL

RESTRICTED MATERIAL

DRAWN FROM ORD. PART NO. 7188702  
ROCK ISLAND ARSENAL  
DEPT OF THE ARMY  
ROCK ISLAND, ILL.

SCALE: FULL	MATERIAL: SEE NOTE 3	DATE:	TOLERANCES: DIM. ± .005 RADIUS ± .005 ANGLES ± 0°
	SEE NOTE 2	REV:	
TITLE: MODEL 37 LEFT HAND SIDE PLATE			NO.

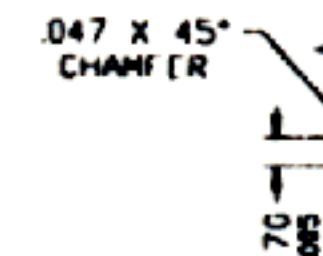
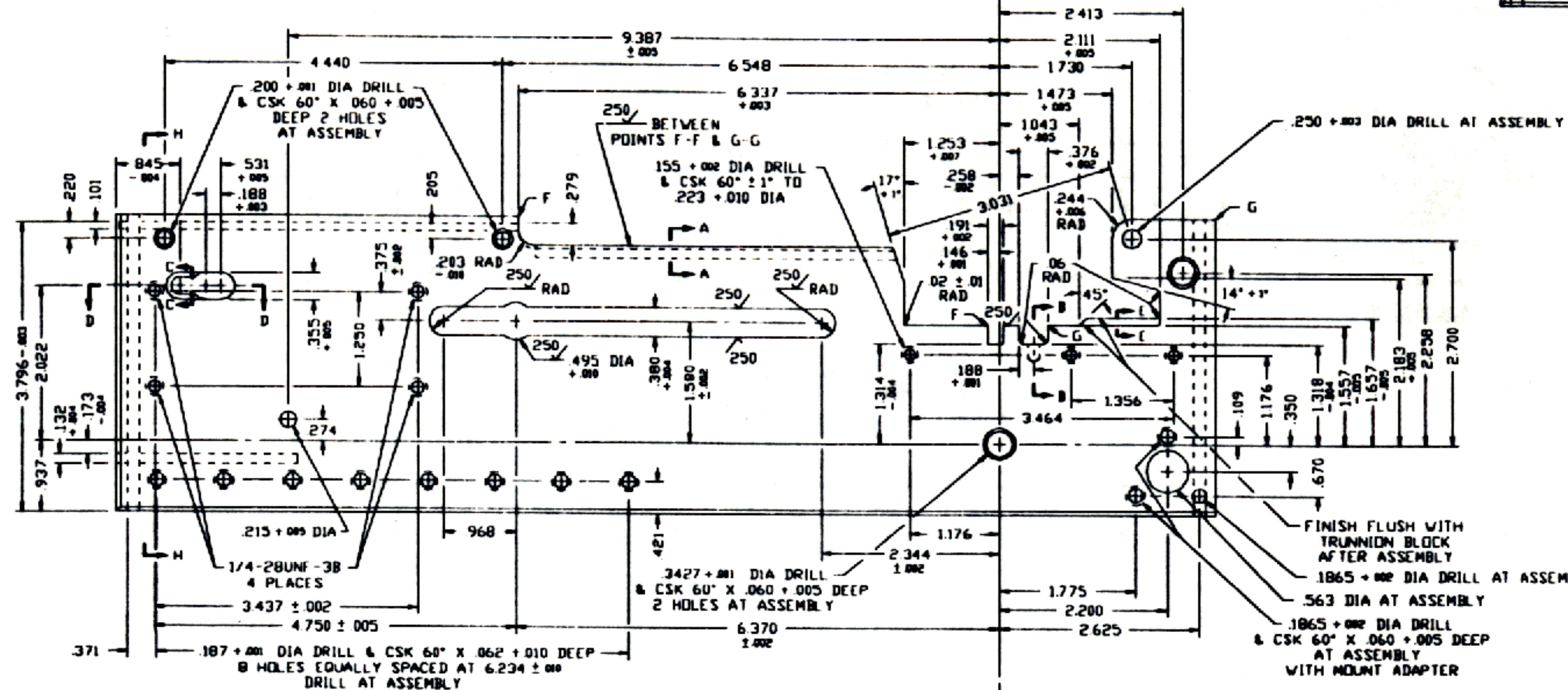
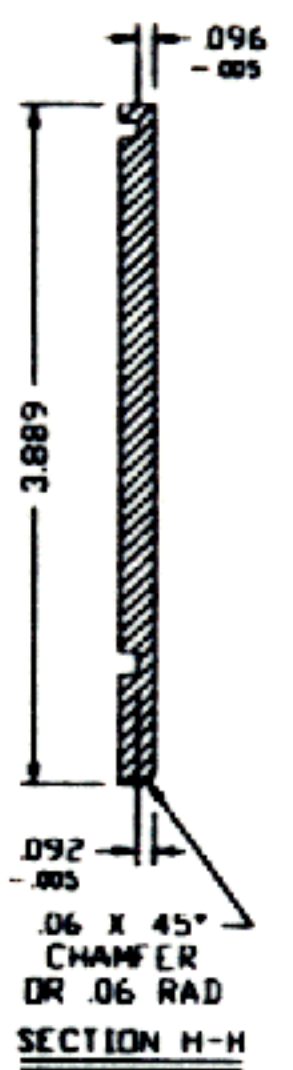
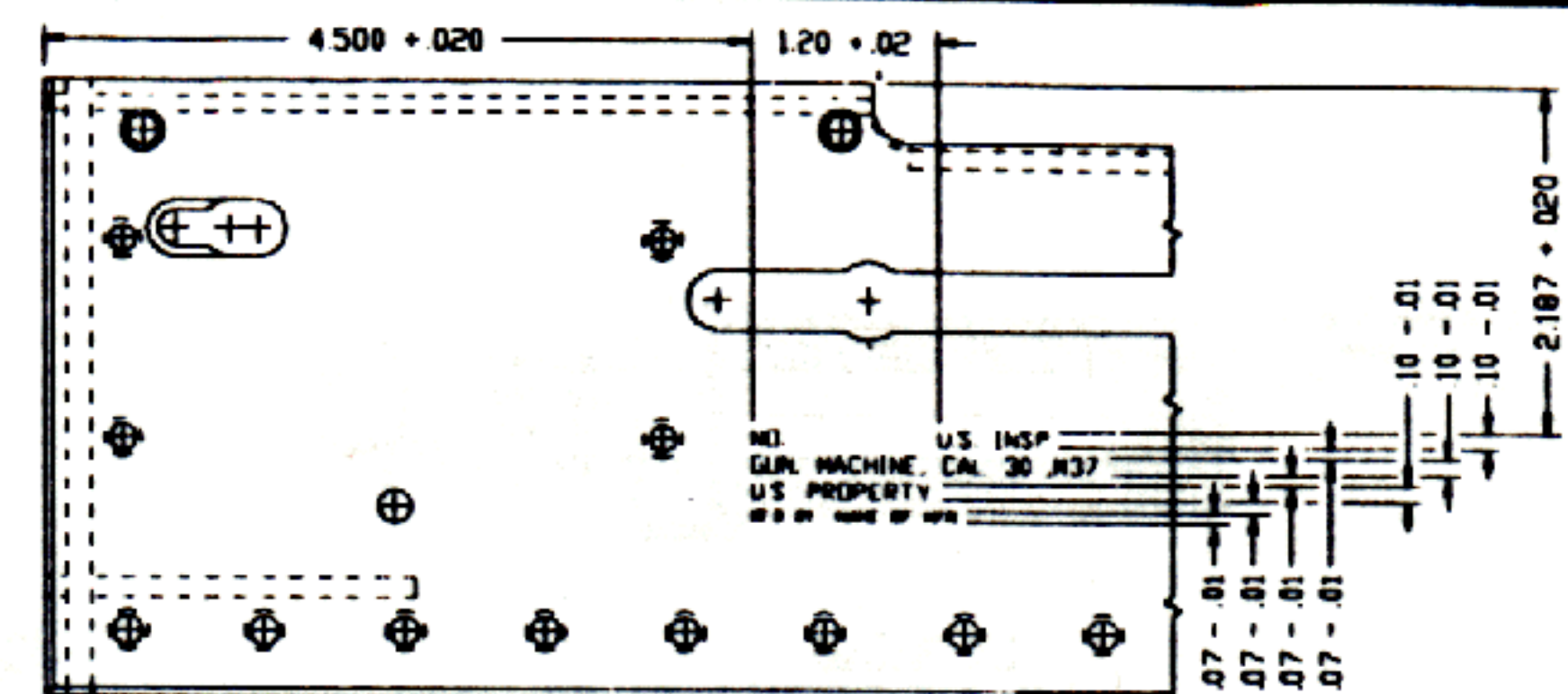
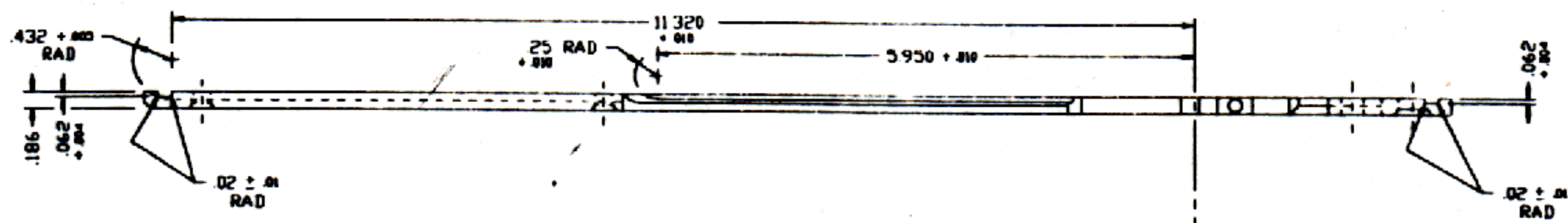

SECTION A-A

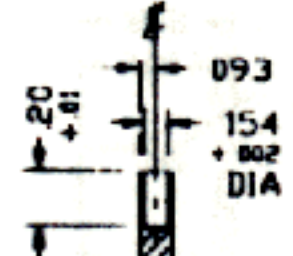

SECTION B-B

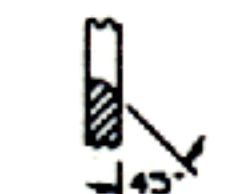

SECTION E-E

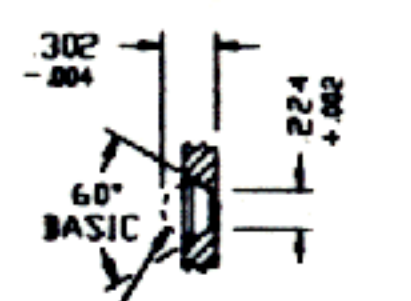

SECTION C-C



SECTION D-D

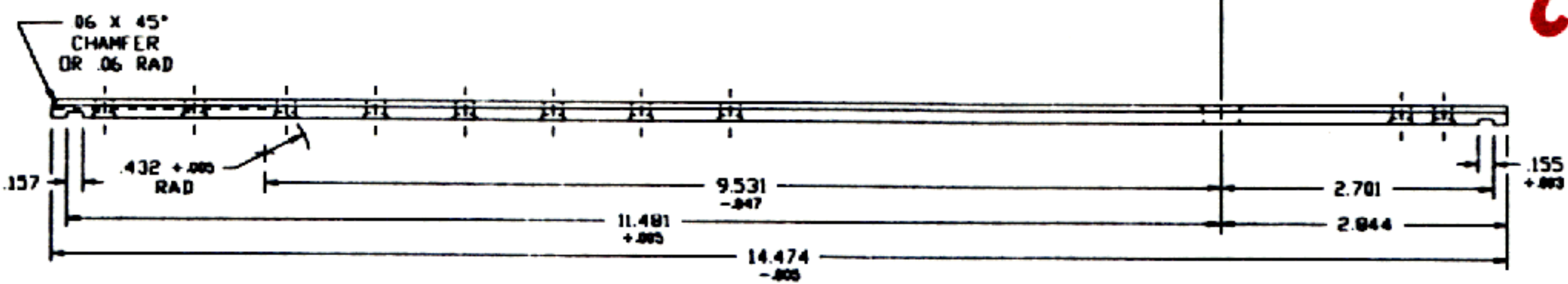

**CONFIDENTIAL**

- NOTES:
1. 125/ ALL OVER EXCEPT AS NOTED
  2. FINISH- PARKERIZE
  3. ORIGINAL MATERIAL STEEL FS4042, FS4047, FS4640 PER MIL SPEC QQ-S-624
  4. HEAT TREAT REAR END FOR ONE INCH ROCKWELL 'C'43-49 ANNEAL AROUND FOUR HOLES.

RESTRICTED MATERIAL

DRAWN FROM DRD. PART NO. 8414730  
 ROCK ISLAND ARSENAL  
 DEPT OF THE ARMY  
 ROCK ISLAND, ILL.

SCALE	FULL	MATERIAL	SEE NOTE 3	CAD	TELEMETRICS
DATE		FINISH	SEE NOTE 2	DATE	REV. 1
TITLE	MODEL 37 RIGHT HAND SIDE PLATE				REV. 2
					REV. 3
					REV. 4
					REV. 5
					REV. 6
					REV. 7
					REV. 8
					REV. 9
					REV. 10

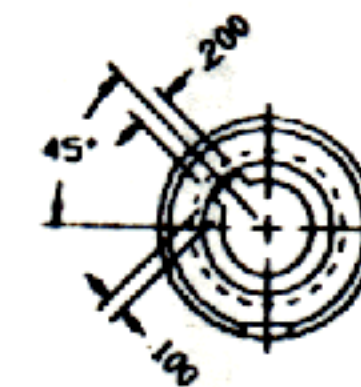
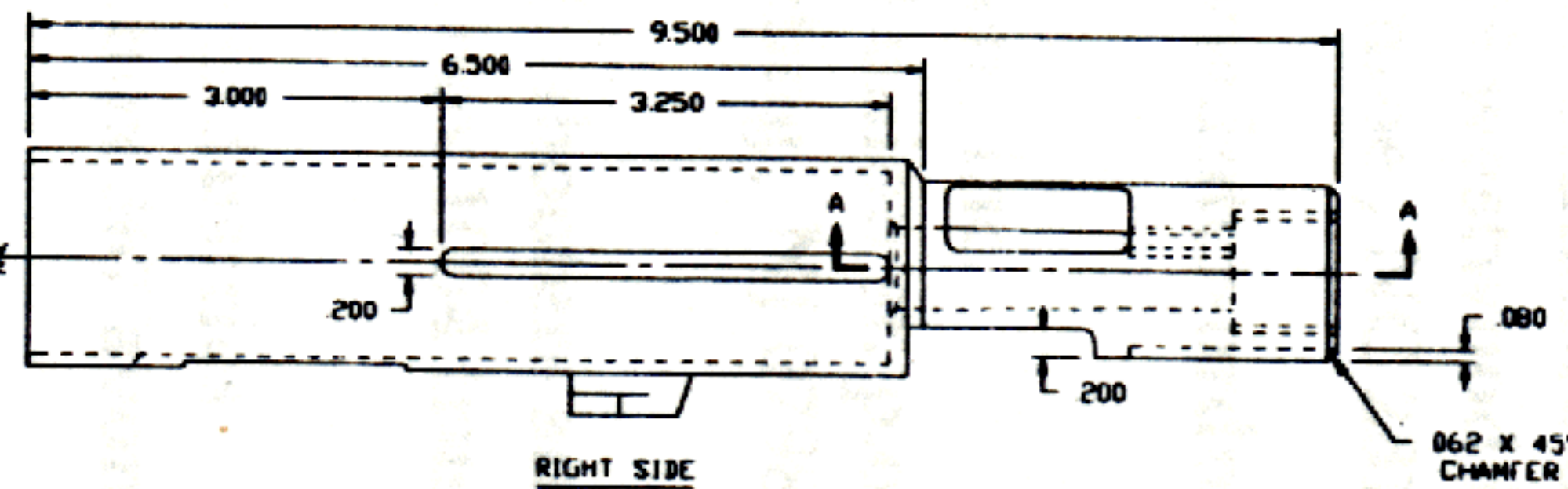
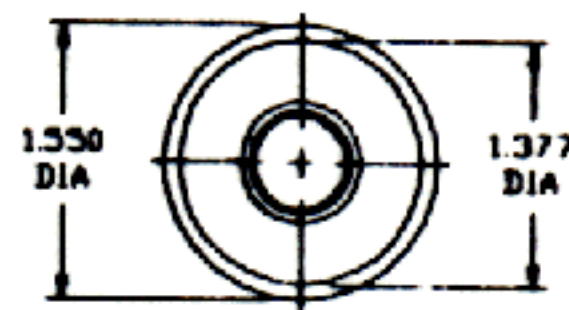

EXTRACTOR SLOT RUNS FROM REAR END OF THREAD TO FRONT OF EXTRACTION PORT

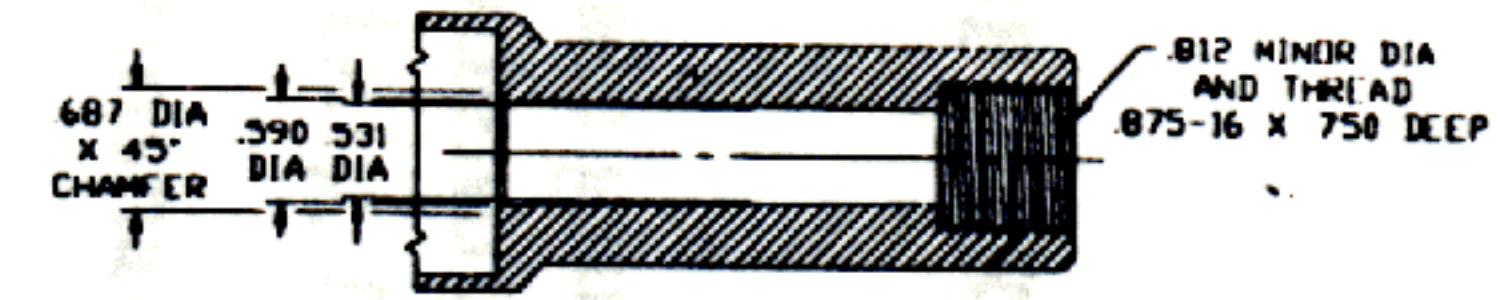

SECTION A-A  
TAPERED BOLT HOLE

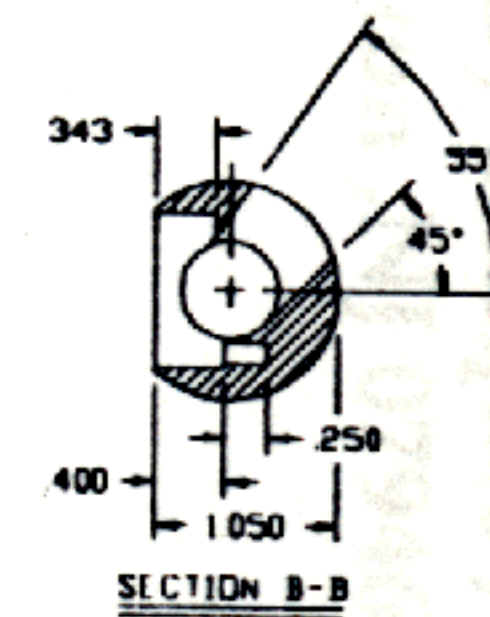
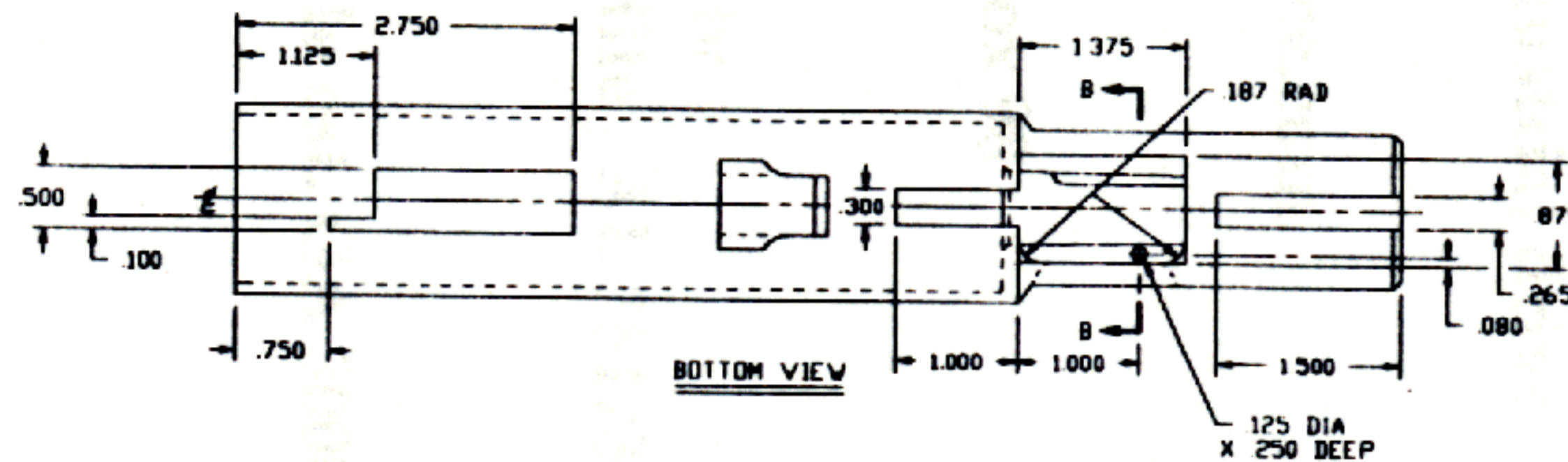

SECTION B-B

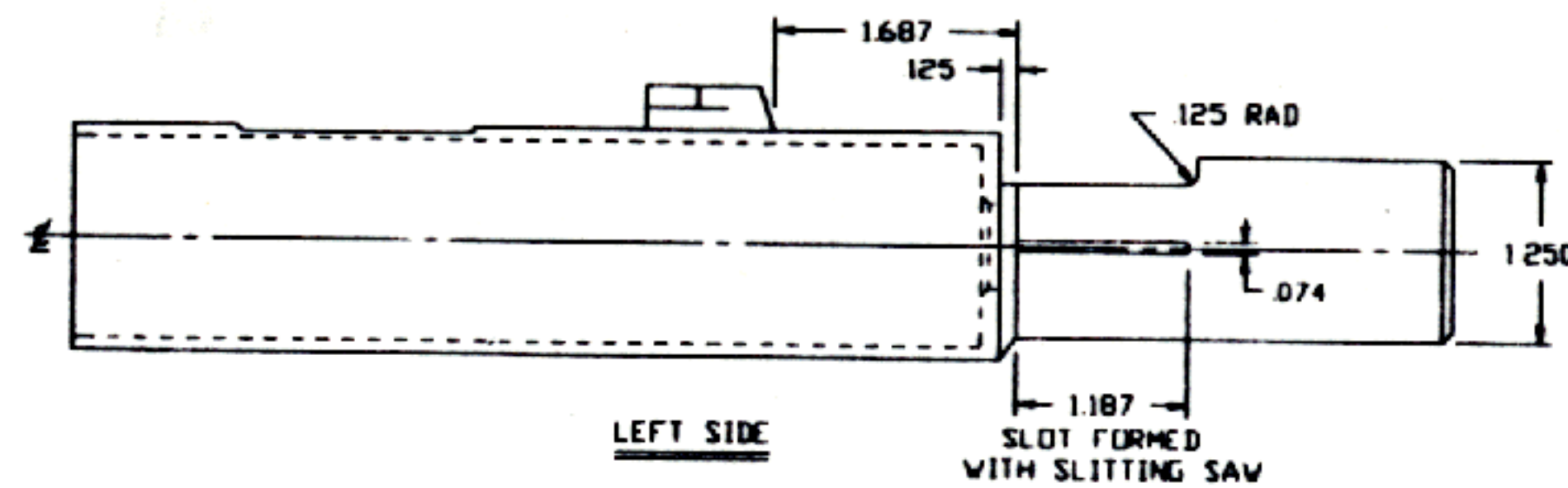
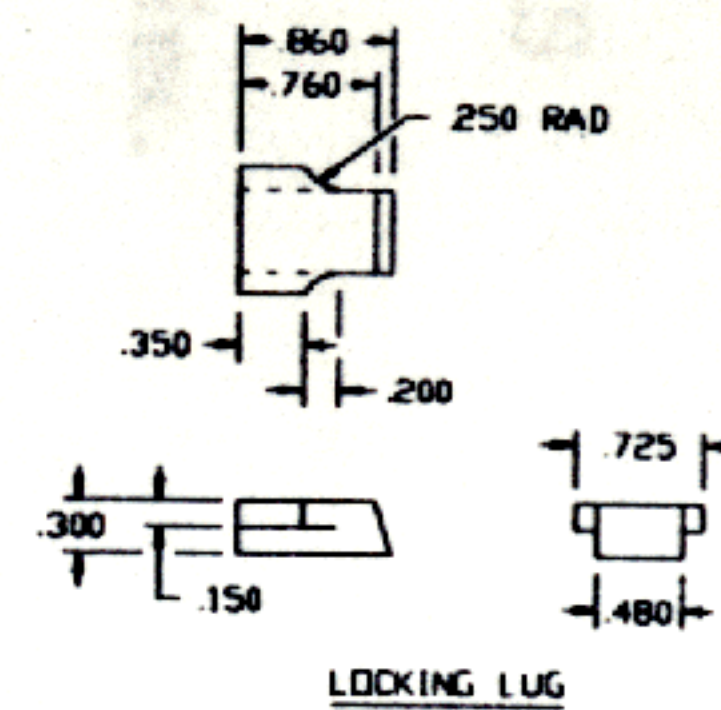

**CONFIDENTIAL**

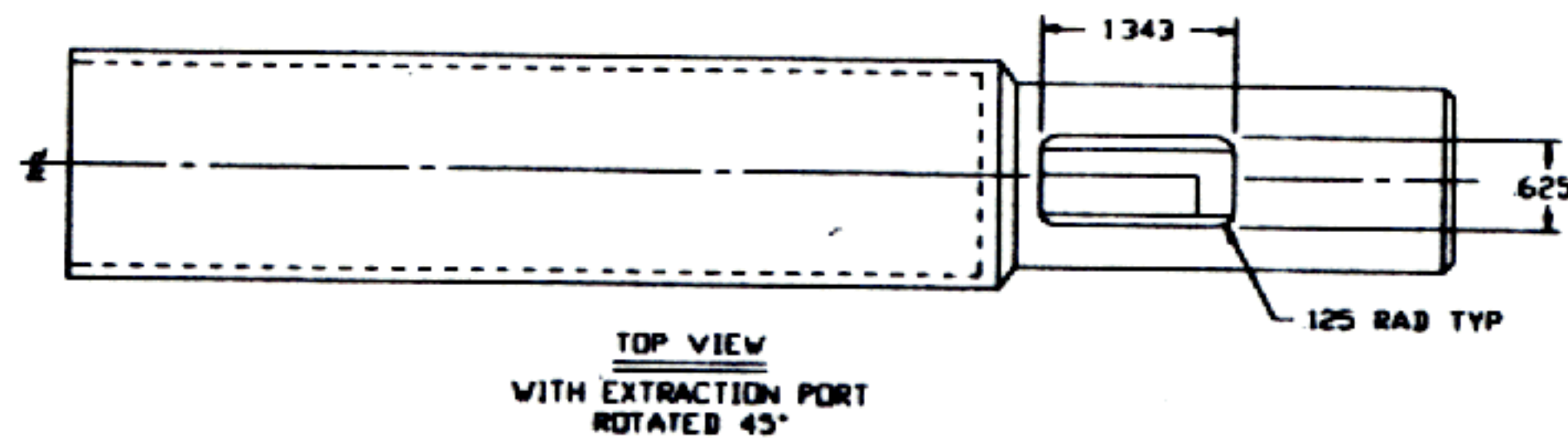
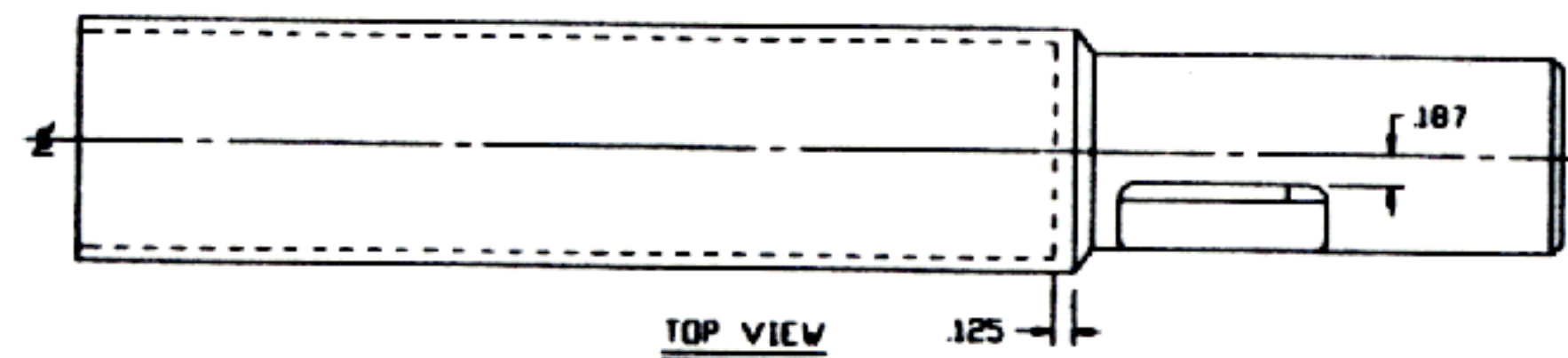

NOTES:

1. MATERIAL - COLD ROLL, HOT ROLL, 4130, 4140 OR 4340 STEEL
2. FINISH - BLUE
3. HEAT TREATMENT - 4130, 4140, 4340 28-32 R/C

**RESTRICTED MATERIAL**

SCALE	FULL	MATERIAL	SEE NOTE 1	CHK		TOLERANCES
FIN		FINISH	SEE NOTE 2	DATE		DEC. 2 PL. ± .005
TITLE	LD-M42 RECEIVER		REV.			DEC. 2 PL. ± .005
						ANGLES ± .5°
						NO.

## **LIST OF PARTS SUPPLIERS**

**wholesale guns and ammo, inc.  
232 blydenburgh rd.  
central islip, NY 11722**

**[www.gunsnammo.com](http://www.gunsnammo.com)**

**international military antiques , inc.  
p.o.box 256 millington ,NJ 07946**

**[www.ima-usa.com](http://www.ima-usa.com)**

**inter ordnance of america l.p.  
3305 westwood industrial drive  
monroe , NC 28110**

**[www.inter-ordnance.com](http://www.inter-ordnance.com)**

**sarco , inc.  
323 union st. p.o. box 98  
stirling , NJ 07980**

**jeffs shooters supply  
p.o.box 1054 trussville , AL 35173**

**rpb industries  
p.o.box 367 avondale est. GA 30002**