



NAMPA FIRE DEPARTMENT



MIDDLETON-STAR FIRE DEPARTMENT



CALDWELL FIRE DEPARTMENT



WILDER RURAL FIRE DISTRICT

**ACCESS & WATER SUPPLY PERMIT APPLICATION
RESIDENTIAL / COMMERCIAL / ACCESSORY BUILDING**

(Refer to Fee Schedule)

Parcel Number _____ Applicant Email Address: _____

APPLICANT NAME _____ PHONE _____

SITE ADDRESS _____ CITY _____ ZIP _____

OWNER _____ PHONE _____

MAILING ADDRESS _____ CITY _____ ZIP _____

- Home is located on 5+ acres outside of Impact Area (Idaho Administrative Procedure Act. Title 41, Chapter 2, 41-253)
- Home is located 10+ miles from a fire station (Idaho Administrative Procedure Act. 18, 18.08.01)

REQUIREMENTS FOR ROAD ACCESS AND WATER SUPPLY SEE PG. 2 & 3

ROAD ACCESS

WATER SUPPLY

A SITE PLAN IS REQUIRED FOR EACH PERMIT APPLICATION

Home is in a platted subdivision (provide plat plan):

Subdivision _____ Lot _____ Block _____

Width _____ Turning Radius _____

Show on your site plan how you will comply with the access requirements on the reverse side of this form.

Distance from Access of Roadway to farthest point of structure _____

Vertical Clearance _____ Grade _____

Turnaround YES NO

(If driveway is longer than 150 ft., turnaround is required)

Bridges YES NO

Surface _____

Minimum fire suppression water supply requirement:

Less than 3,600 sq ft. *No additional water supply required.*

Over 3,600 sq ft. under roof, including garage. One of the following options is required:

Annexation to Municipal Water System

Elevated Tank Pressure Tank

Private/Community Well providing required fire flow

OR:

An NFPA 13D Fire Sprinkler System installed in the residence

AHJ alternative method accepted

Note: Separation through construction will not be accepted

****By signing this application, the owner/applicant agrees to the statements made on this application.***

OWNER/APPLICANT SIGNATURE: _____ DATE _____

OFFICE USE ONLY

Application: Approved as submitted

Permit Fee: _____

Application: Approved with the following conditions:

PAID: Check # _____ Credit Card _____

Fire Official Signature: _____ DATE _____

Certificate of Occupancy APPROVED: _____ DATE _____

Access Road Guidelines

Privately maintained Roadway Width, Surface and Turnaround Requirements:

- All access roads serving dwellings shall have a minimum improved driving surface width of 20 feet.
- All roads and bridges shall be designed to meet a 75,000 lb fire apparatus load. Roads and bridges shall be inspected and certified by the applicant's engineer prior to obtaining a certificate of occupancy.
- If the access road exceeds 150 feet in length then a turnaround is required to be placed within 150 feet of the dwellings. See turnaround examples below.
- A vertical clearance of 13 feet 6 inches is required over the width of the access road.
- Existing driveways that add a second residence shall meet the minimum requirements of 4" thick ¾ minus gravel base or equivalent recycled asphalt paving (RAP), graded and compacted with a 20 foot wide all weather driving surface.
- New driveways shall provide a subbase if longer than 150 feet. The subbase shall be 9" of uncrushed aggregate (pit-run). The base shall be 4" thick ¾ minus gravel base or equivalent recycled asphalt paving (RAP), graded and compacted with a 20 foot wide all weather driving surface.
- Driveways serving two (2) properties and all private roads shall have a recorded road users maintenance agreement that describes the responsible parties for construction and maintenance, including repairs, and necessary improvements to accommodate additional accesses in the future. The agreement shall also list any construction warranties applicable to the specific driveway or private road.

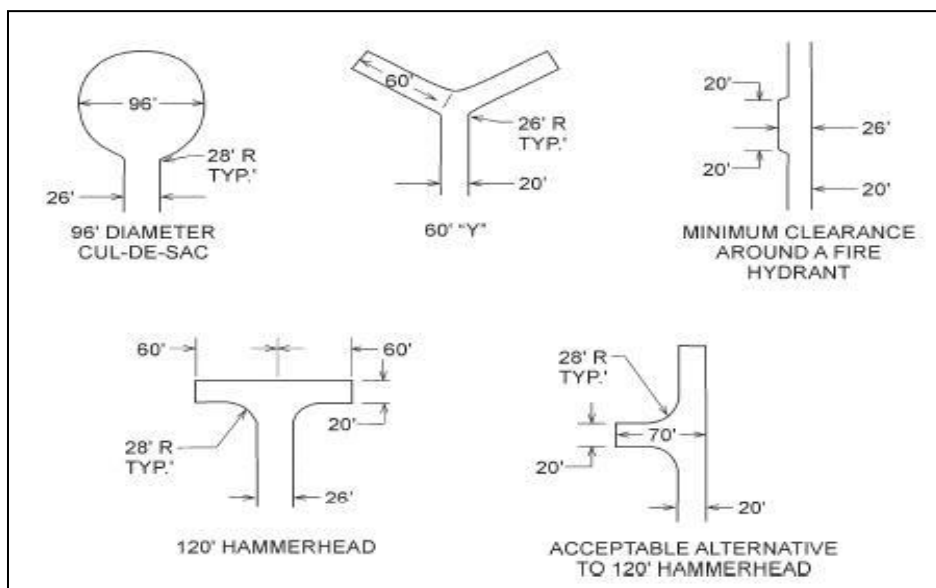

Water Supply for Fire Suppression Fire flow square footage is determined by total occupiable space under the roof deck, including garages, bonus rooms, basements, and exterior porches/patios. (Building plans are required for review to calculate the actual square footage). Dwellings over 3,600 SF are required to have approved fire suppression water supply. The following are the only approved water supply options:

Municipal Water System- A fire hydrant, supplied by a municipal water system capable of the required fire flow per 2018 International Fire Code, Appendix B.

Private and/or Community Well- A fire hydrant, supplied by a private and/or community water system, located within 1,200 feet driving distance of the residence. The hydrant shall be capable of supplying the required fire flow for the structure. To be considered as a water supply the owner/applicant will be required to provide fire flow information from the water purveyor that verifies the well is capable of the required fire flow.

Elevated and Pressure Tanks- A fire hydrant, supplied by a tank with a water capacity of 180,000 gallons, located within 1,200 feet driving distance of the residence.

NFPA 13D Fire Sprinkler System- In lieu of the water systems above an NFPA 13D fire sprinkler system may be installed in the residence. Plans for the design of the fire sprinkler system are required to be submitted to the fire jurisdiction for review and approval. Installation inspections of the system will be carried out by the fire jurisdiction.

The Wilder Fire Board of Commissioners does hereby adopt and enact the following fee schedule to be imposed and collected by this District as a condition of conducting the service of inspection and/or plan review, hereinafter specified, effective October 1, 2024.

FEE SCHEDULE

Service Type	Fee
Commercial Project	
Accessory Building Plan Review	\$35.00
Commercial Hood Review/Inspection	\$150.00
Access & Water Supply Permit	\$200.00
Fire Alarm System Plan Review/Inspection	\$200.00+\$2.50/Device
Fire Sprinkler Plan Review/Inspection	\$200.00+\$2.50/Device
Plan Review Fire Code / Special Events Permit	\$100.00
Residential Project	
Commercial Hood Review/Inspection	\$150.00
Access & Water Supply Permit	\$100.00
Fire Alarm System Plan Review/Inspection	\$200.00+\$2.50/Device
Fire Sprinkler Plan Review/Inspection	\$200.00+\$2.50/Device
Planned Unit Development / Multi-Family Plan Review	\$150.00
Preliminary/Final Plat Review	\$150.00
Other Inspections	
Change of Occupancy	\$30.00
Day Care Inspections	\$30.00
Fireworks Stands	\$50.00
Fireworks Public Displays	\$50.00
Food Truck/Mobile Preparation Vehicle	\$25.00
Hazardous Material Tank/Storage	\$100.00
Manufactured Home Park Review	\$200.00
Re-Zoning Application	\$100.00
Tents, Canopies & Temporary Membrane Structures	\$25.00