



# LED Optimized Drivers

## 40 Watt - LP40W-56-PC1500-RD

FLICKER FREE PROGRAMMABLE LED DRIVER WITH 0-10V DIMMING & 12V AUX



PROGRAMMABLE  
LP40W  
40W

### Model: LP40W Series

- Drive Mode: Flicker Free Programmable Constant Current
- Technology: PFC Corrected 2-Stage Switch Mode
- Output Power: 40W Max.
- Input Voltage: 120 to 277VAC, 50/60Hz
- Output Voltage: 12 - 56VDC
- Output Current: Set by resistor value (Rset) or GUI
- Programmable Output Current (POC): 300 - 1500mA
- 0-10V Linear or LOG Dimming 0% - 100%
- Auxiliary Output: 12V @ 200mA Max.

### Environmental

1. Operating temperature: Tc 85C Maximum.
2. UL Class P
3. Storage temperature range: -40 to +85°C
4. Humidity (non-condensing): 5% - 90%RH
5. Cooling: Convection
6. Vibration Frequency: 5-55Hz/2g, 30 minutes
7. Impact resistance: 1g/s
8. MTBF@ 25°C: 362,000 hours @ Full Load per MIL-217F Notice 2.

### Safety and Compliance

1. UL8750, EN61347, CSA 22.2 safety listed, UL Class P
2. FCC, 47CFR Part 15 Class A certified
3. Damp & Dust resistant design IP20 NEMA1, for Dry & Damp Locations.
4. Rectangular style metal case with or without mount studs.
5. Safety Isolation between Primary and Secondary
6. Meets EN61000-3-2 & EN61000-3-3 Class C
7. Protection: output over-voltage, output over-current, output short circuit, auto-recovery.
8. EN61000-4-5: 2kV/4kV 8/20 μsec transient protection.

### Electrical Specifications at 25°C

- Input voltage range: 120-277Vac (Full range 108 to 305Vac)
- Frequency: 47 - 63HZ
- Power Factor: ≥ 0.90 at ≥ 60% Output Power, 120Vac/230Vac/277Vac 50/60Hz
- THD%: ≤ 20% at ≥ 60% Output Power, 120Vac/230Vac/277Vac 50/60Hz
- Inrush current: <30A at 25C, 277Vac, cold start, Max. Load
- Input current: 0.41A Maximum @ 120Vac
- Efficiency: 84% typical at 230Vac Full Load
- Constant Current regulation: ± 2% Over Input Line Variation
- Load regulation accuracy: ± 3%
- Leakage current: <750uA Max

### Programmable Parameters

Programmable Parameter	Programmable Minimum Value	Programmable Maximum Value	Factory Default	GUI Programmable	RSET Programmable	
Output Constant Current (Iout)	300 mA (150mA)	1500 mA	700 mA	YES	YES	
Disable Dimming?	NO	YES	NO	YES	N/A	
Dimming Curve	LINEAR	0%	N/A Fixed 100%	0%	YES	N/A
	LOG	0%	N/A Fixed 100%	0%	YES	N/A
NTC Minimum Ohms	1K Ω	10K Ω	2K Ω	YES	N/A	
NTC Minimum %Iout	~ 0%	100%	~ 10%	YES	N/A	
NTC Maximum Ohms	2K Ω	10K Ω	6.3K Ω	YES	N/A	

**Output Current:** Set by Resistor Value "Rset" or using EP Programmer USB interface & EPtronics PC based GUI Software.

When Rset is open (no resistor present) then GUI setting controls programmed output current.

Programmable Output Current (POC): 300 - 1500mA Power limited to 40W maximum by Voltage foldback. Can be set <300ma & >150mA with ±10% Iout tolerance.

### Programmable Constant Current Version



IP20



Part Number <sup>(1)</sup>	US Class 2	CN Class 2	Output Voltage Range	Output Constant Current <sup>(3)(4)</sup>	Current Accuracy	Output Power Maximum <sup>(3)</sup>	Typical Efficiency <sup>(2)</sup>
LP40W-56-PC1500-RD	YES	YES	12 - 56 VDC	300 mA to 1500 mA	± 5%	40W	82%

### Notes

1. For alternate case style with 2 each #8-32 Studs add "S" to end of part number: LP40W-56-PC1500-RDS. Refer to drawing on Page 3. Standard case color is Black. For White case add "W" to the end of the part number: LP40W-56-PC1500-RDW or LP40W-56-PC1500-RDSW
2. Typical efficiency measured at 230VAC input, Iout 1.0A, full load
3. Keep POC (Programmable Output Current) within 25W Maximum Power Operating Window. Refer to Power Operating Window graph. Part will foldback output Voltage to maintain power limits.
4. See page 8 for programmable output current (POC) graphs.
5. See page 10 for NTC graphs
6. See page 11 for GUI programmable version.

Custom designs available. Please consult with the factory.

Specifications subject to change without notice

**40W**  
**LP40W**

PROGRAMMABLE



**LED Optimized Drivers**

# 40 Watt - LP40W-56-PC1500-RD

FLICKER FREE PROGRAMMABLE LED DRIVER WITH 0-10V DIMMING & 12V AUX

## Mechanical Dimensions: Inches [mm]

Material: Metal Housing  
Weight: 7.7 oz ( 218 grams) Typical  
Case must be grounded in end use application

## Standard Housing: LP40W-56-PC1500-RD

Standard case color is black.  
For white case add "W" to the end of the part number:  
LP40W-56-PC1500-RDW

## Labeling Example

**Programmable LED Optimized Driver**  
EPtronics, Inc.  
www.EPtronics.com  
800.643.0688/310.536.0700

AC INPUT  
N = WHITE  
L = BLACK  
FG = GREEN

Part Number: LP40W-56-PC1500-RD  
Input Voltage: 120-277VAC 50/60Hz  
Input Current: 0.56 Amp Max  
Output Voltage: 12-56 VDC  
Output Current (POC): 300-1500 mA (Default 700mA)  
0-10V CCR Dimmable Output, Programmable  
Programmable NTC and Dimming Curve  
UL & cUL Class 2 Output & Class 2 Dimming  
UL Class P, For Connections use wire rated ≥ 90C (194F)  
Suitable for Damp Locations

**CE** **RoHS**

**OUTPUT & CONTROLS**

LED- = BLUE  
LED+ = RED  
12V@200mA = YELLOW  
SCOM (P-) = GRAY  
DIM+ = PURPLE  
RSET = GRAY  
NTC (P+) = GRAY

**GROUNDING:**  
Driver case must be grounded.  
**Connector Wiring:**  
Use 18 AWG Solid Wire rated ≥300V  
≥ 90C (194F) Strip back 3/8" (9.5mm)

**FC** **IP20** **UL LISTED**  
E325626  
HG Made in China REV A

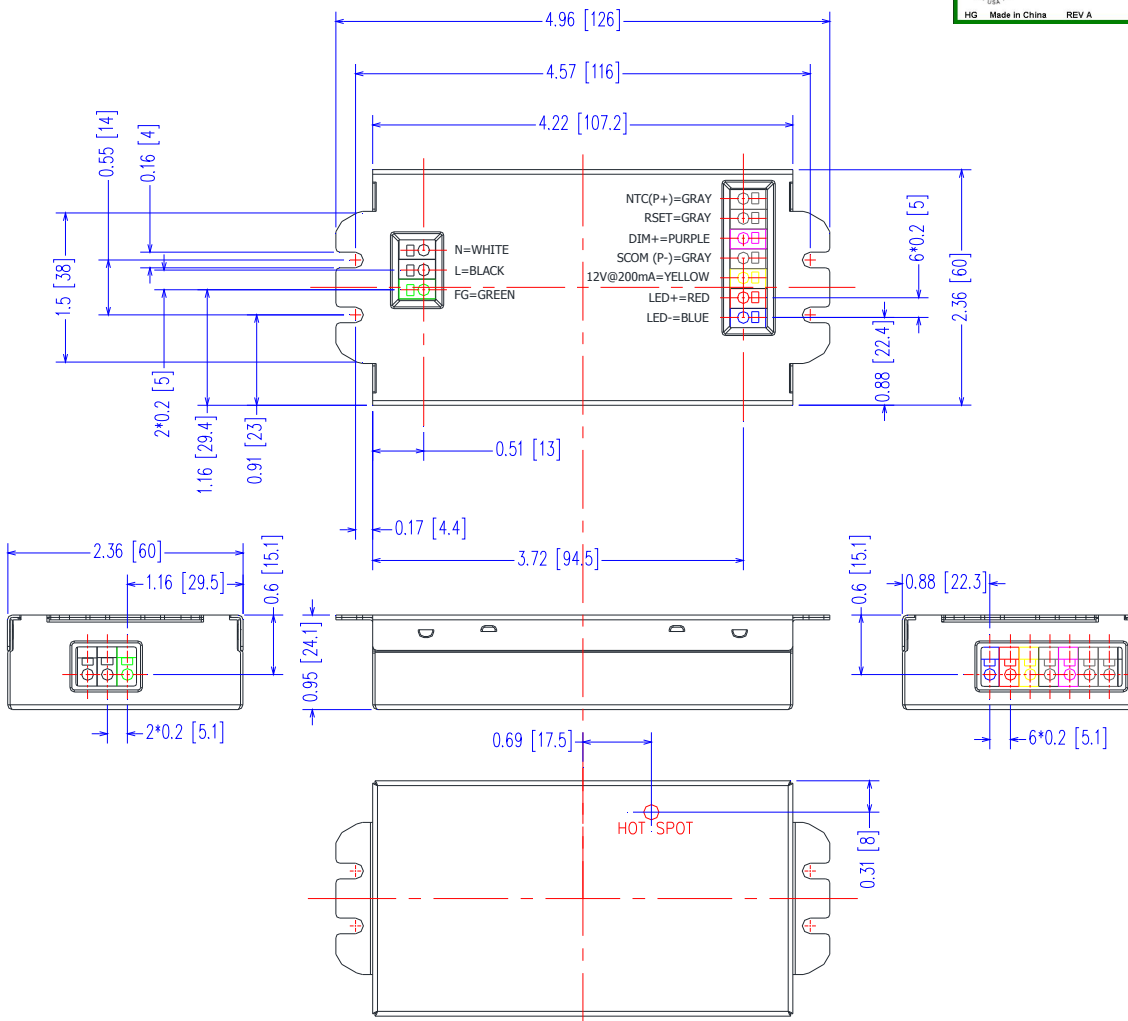

Case Parameter	Inches [mm]
Length	4.96 [126]
Width	2.36 [60]
Height	0.95 [24.1]
Connectors	UL, KF253, WAGO 253 Push Pin or equivalent.

## LED wiring distance

Recommended maximum wiring distance at full load.

AWG	#22	#21	#20	#19	#18
Distance (m)	10	12	14	18	22
Distance (ft)	32.8	39.4	45.9	59	72.2

## 40 Watt - LP40W-56-PC1500-RD

FLICKER FREE PROGRAMMABLE LED DRIVER WITH 0-10V DIMMING & 12V AUX

### Mechanical Dimensions: Inches [mm]

Material: Alternate Metal Housing  
 Weight: 7.7 oz ( 218 grams) Typical  
 Case must be grounded in end use application  
 Includes 2x#8-32 Threaded studs for mounting.  
 No side connectors.

### Alternate Housing: LP40W-56-PC1500-RDS Includes 2x#8-32 Studs for mounting, No side connectors.

Standard case color is black.  
 For white case add "W" to the end of the part number: LP40W-56-PC1500-RDSW

### Labeling Example

**Programmable LED Optimized Driver**  
EPtronics, Inc.  
www.EPtronics.com  
800.643.0688/310.536.0700

**Part Number: LP40W-56-PC1500-RDS**  
**Input Voltage: 120-277VAC 50/60Hz**  
**Input Current: 0.56 Amp Max**  
**Output Voltage: 12-56 VDC**  
**Output Current (POC): 300-1500 mA (Default 700mA)**  
**0-10V CCR Dimmable Output, Programmable**  
**Programmable NTC and Dimming Curve**  
**UL & cUL Class 2 Output & Class 2 Dimming**  
**UL Class P, For Connections use wire rated ≥ 90C (194F)**  
**Suitable for Damp Locations**

**AC INPUT:** L = BLACK, N = WHITE, FG = GREEN

**OUTPUT & CONTROLS:** LED+ = RED, LED- = BLUE, 12V@200mA = YELLOW, SCOM (P-) = GRAY, DIM+ = PURPLE, DIM- = PURPLE, RSET = GRAY, NTC (P+) = GRAY

**GROUNDING:** Driver case must be grounded.  
**Connector Wiring:** Use 18 AWG Solid Wire rated ≥300V ≥ 90C (194F) Strip back 3/8" (9.5mm)

**UL LISTED** E325626

**IP20** **FC** **UL** **USA** **MADE IN CHINA** **REV A**

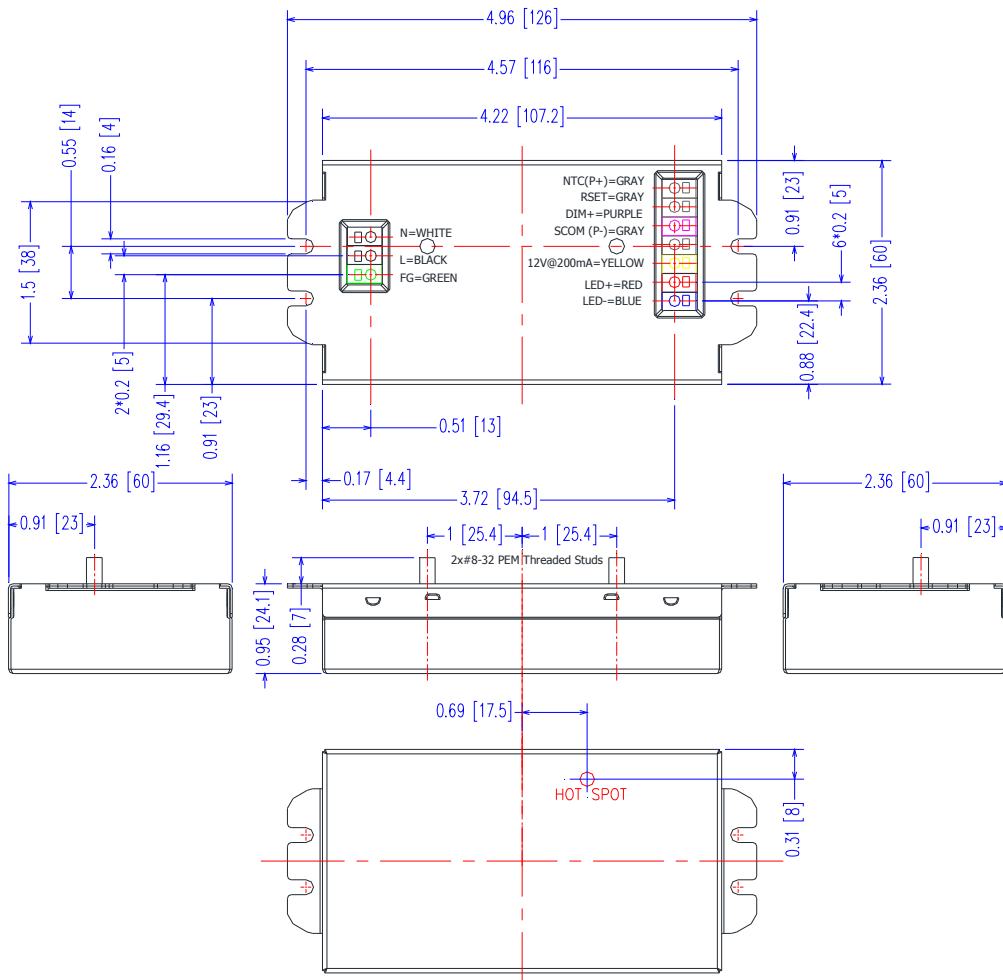

Case Parameter	Inches [mm]
Length	4.96 [126]
Width	2.36 [60]
Height	0.95 [24.1]
Connectors	UL, KF253, WAGO 253 Push Pin or equivalent.

### LED wiring distance

Recommended maximum wiring distance at full load.

AWG	#22	#21	#20	#19	#18
Distance (m)	10	12	14	18	22
Distance (ft)	32.8	39.4	45.9	59	72.2

# 40 Watt - LP40W-56-PC1500-RD

FLICKER FREE PROGRAMMABLE LED DRIVER WITH 0-10V DIMMING & 12V AUX

## -RD, 0-10V & Resistance Dimming Scheme

Parameters	Minimum	Typical	Maximum
12V Auxiliary Output	11V	12.0V	13.0V
12V Auxiliary Output Source Current	0mA	—	200mA
Absolute Voltage Range on 0-10V Input (Purple Wire)	-2.0V	—	+15V
Source Current out of 0-10V Input (Purple Wire)	0mA	—	1.0mA

## Notes

1. Part comes with DIM+, COM & +12V auxiliary connectors. DIM+ and +12V return are connected to COM (DIM-)
2. Part is compatible with most 0-10V Wall Slide dimmers and direct 0-10V analog signal. Recommended dimmer is Leviton IP710 or equivalent connected between Purple and COM wires. +12V auxiliary is not used for dimming.
3. Output current will be Minimum Programmed Value when  $V_{dim} \leq 1.00V$ . If set to 0% then this is dim to zero operation.
4. Output will be 100% with DIM+/COM open and Minimum Programmed Value with DIM+/COM Shorted.
5. Minimum dimming level is programmable with EP Programmer GUI.

## -RD 2-Wire Resistance Dimming Scheme

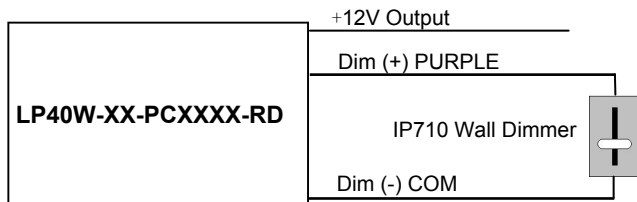

## -RD 2-Wire 0-10V Dimming Scheme

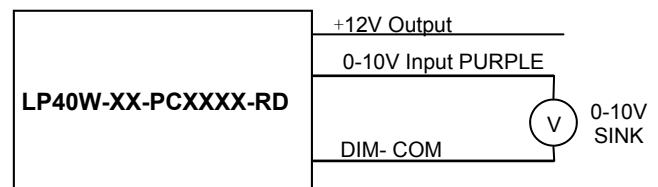

## Typical Dim Curves: Iout Min set to 0%

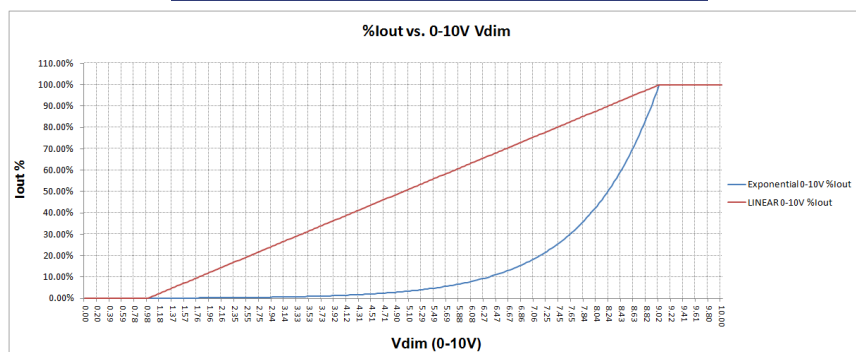

## Typical Dim Curves: Iout Min set to 10%

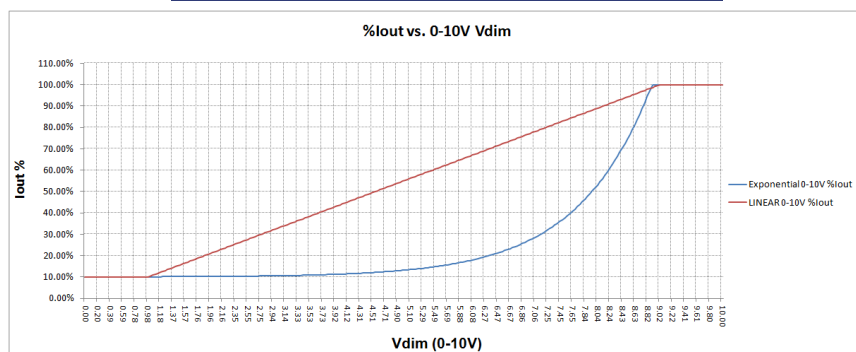

## 40 Watt - LP40W-56-PC1500-RD

FLICKER FREE PROGRAMMABLE LED DRIVER WITH 0-10V DIMMING &amp; 12V AUX

### Input Specifications

Parameter	Min.	Typ.	Max.	Notes/Conditions
Input Voltage	108 Vac	—	305 Vac	120, 230, 240, 277 Vac Nominal Values
Input Frequency	47 Hz	—	63 Hz	50/60Hz Nominal
Input AC Current	—	—	0.41 A	Measured at 120Vac/60Hz Input, Output Full load.
	—	—	0.19 A	Measured at 277Vac/60Hz Input, Output Full load.
Inrush Current (Peak) Note: Ipk Pw ~30usec max	—	—	14A	Measured at 120Vac/60Hz Input, Output Full Load, Ta 25°C, Cold Start
	—	—	30A	Measured at 277Vac/60Hz Input, Output Full Load, Ta 25°C, Cold Start
Leakage Current	—	—	0.50mA	Measured at 120Vac/60Hz Input, Output Full load.
	—	—	0.70mA	Measured at 277Vac/60Hz Input, Output Full load.
THD	—	—	20%	Measured at 120, 230, 277Vac Input, Output Power ≥60%
Power Factor (PF)	0.90	—	—	Measured at 120, 230, 277Vac Input, Output Power ≥60%

### Output Specifications

Parameter	Min.	Typ.	Max.	Notes/Conditions
DC Output Voltage	Per Table	—	Per Table	Per Table on Page 1
DC Output Current (POC) 300-1500mA	-5%	Per Table	+5%	Programmable Output Current (POC) POC is set using Rset resistor Per table on Page 8 or GUI
DC Output Current (POC) 100-300mA	-10%	Per Table	+10%	Programmable Output Current (POC) POC is set using Rset resistor Per table on Page 8 or GUI
Output Power	—	—	41W	Voltage Foldback
Ripple & Noise (Vpk-pk)	—	—	3% Vo	20 MHz BW, Full load output in parallel with 0.1 μF ceramic & 10 μF Electrolytic.
Ripple (Ipk-pk)	—	—	5% Io	20 MHz BW, Full load output in parallel with 0.1 μF ceramic & 10 μF Electrolytic. 120 Hz component (Flicker Free)
Start-up Time	—	400 mS	750 mS	Measured at Vout 80%, 277Vac/60Hz Input, Output Full load
Hold-up Time	—	30 mS	—	Typical @ 277Vac Input, Output Full load.
Auxiliary Output (V)	11	12	13	@ 200mA Maximum

### Environmental Specifications

Parameter	Min.	Typ.	Max.	Notes/Conditions
Case Temperature (Tc)	-30 °C	—	+85 °C	Measured at location specified on case.
Operating Temperature (Ta)	-30 °C	—	+40 °C	This is a reference range. Tc controls temperature range.
Storage Temperature (Ts)	-40 °C	—	+100 °C	Non operating temperature range.
Operating Humidity	—	—	90% RH	Relative Humidity, non-condensing.
Vibration	5 Hz	—	55 Hz	2G, 10 minutes/1 cycle, period 30 minutes, each along X, Y, Z axis.
MTBF	—	362,000 Hours	—	MIL-HDBK-217F Notice 2, Ta = 25C, Output Full Load.

### Protection Specifications

Parameter	Min.	Typ.	Max.	Notes/Conditions
Output Short Circuit (SCP)	—	—	—	No Damage, Auto recovery after short is removed.
Output Over Current (OCP)	—	—	+8% Io	Constant Current Limiting circuit.
Output Over Voltage (OVP)	—	—	105% Vo	No Damage, Auto recovery after fault is removed.
Output Power Limit (OPL)	—	—	40W	Voltage Foldback

40W  
LP40W

PROGRAMMABLE



LED Optimized Drivers

# 40 Watt - LP40W-56-PC1500-RD

FLICKER FREE PROGRAMMABLE LED DRIVER WITH 0-10V DIMMING & 12V AUX

## Safety & Compliance

Safety	Notes/Standards
UL/CUL Listed UL Class P	UL8750 & CAN/CSA C22.2 No. 250.13, UL Class P
CE	EN61347-1, EN61347-2-13
Withstand Voltage	Input to Output: 3750 Vac
Isolation Resistance	Input to Output: >100 MΩ, 500VDC @ 25 °C, 70 % RH
0-10V Dimming Circuit	Dim+ Purple/Dim- Gray are considered part of the secondary circuit.
FG	The metal case of the driver must be connected to earth ground (FG) in the end-use application.
Sound Rating	<24dB Class A

## EMC Compliance

Standard	Notes/Conditions
FCC, 47CFR Part 15	Class A
EN 55015	Limits and methods of measurement of radio disturbance characteristics of electrical lighting and similar equipment.
EN 61000-3-2	Part 3-2: Limits for harmonic current emissions Class C, ≥80% Rated Power
EN 61000-3-3	Part 3-3: Limitation of voltage changes, voltage fluctuations and flicker.
EN 61000-4-5	Part 4-5: Surge Immunity test, 2 kV L-N, 4 kV L-FG & N-FG
Energy Star	Energy Star transient protection: Ballast or driver shall comply with ANSI/IEEE C62.41.1-2002 and ANSI/IEEE C62.41.2-2002, Category A operation. The line transient shall consist of seven strikes of a 100 kHz ring wave, 2.5 kV level, for both common mode and differential mode.

## Power Factor Curves (Typical): Vout 26V @ Iout 1500mA

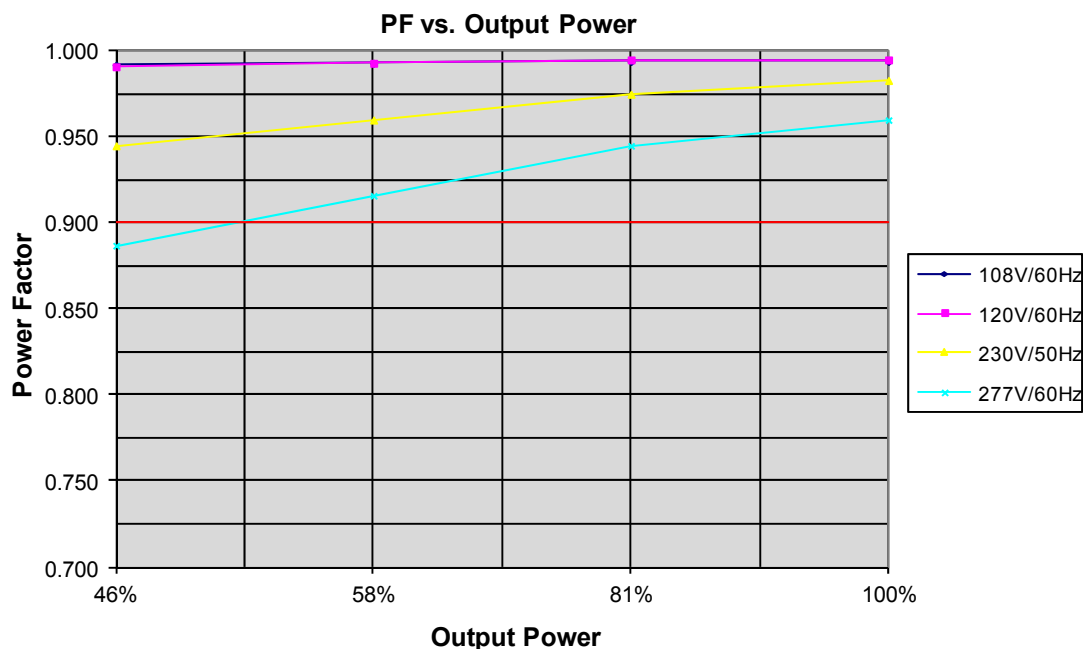



## 40 Watt - LP40W-56-PC1500-RD

FLICKER FREE PROGRAMMABLE LED DRIVER WITH 0-10V DIMMING & 12V AUX

THD Curves (Typical): Vout 26V @ Iout 1500mA

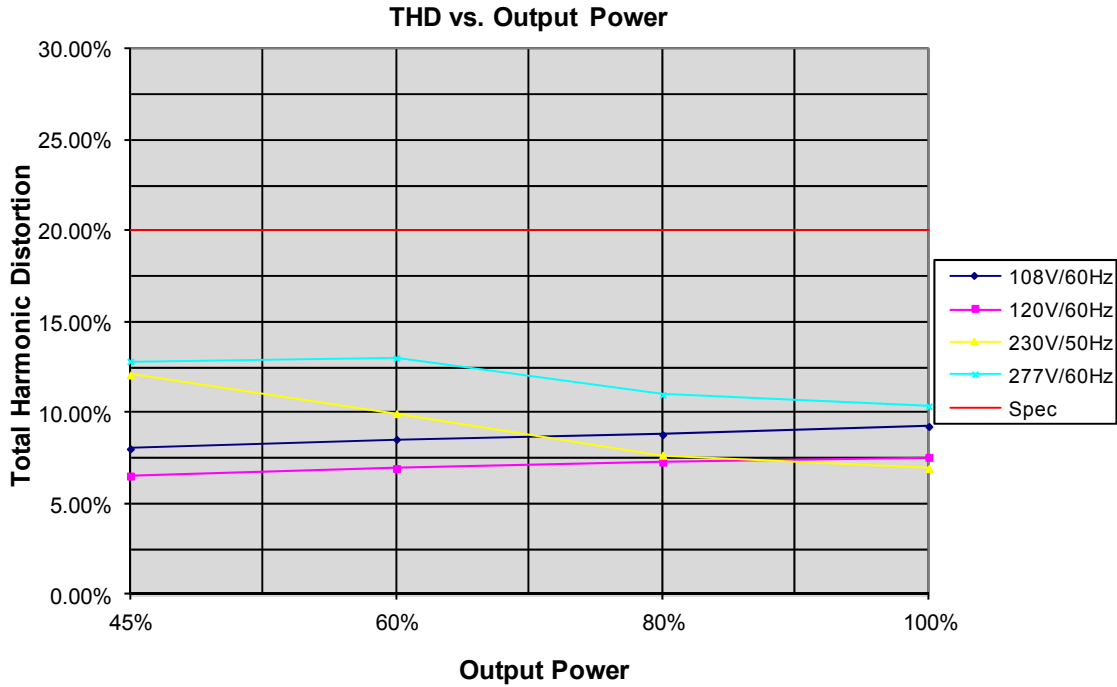

Efficiency Curves (Typical): Vout 26V @ Iout 1500mA

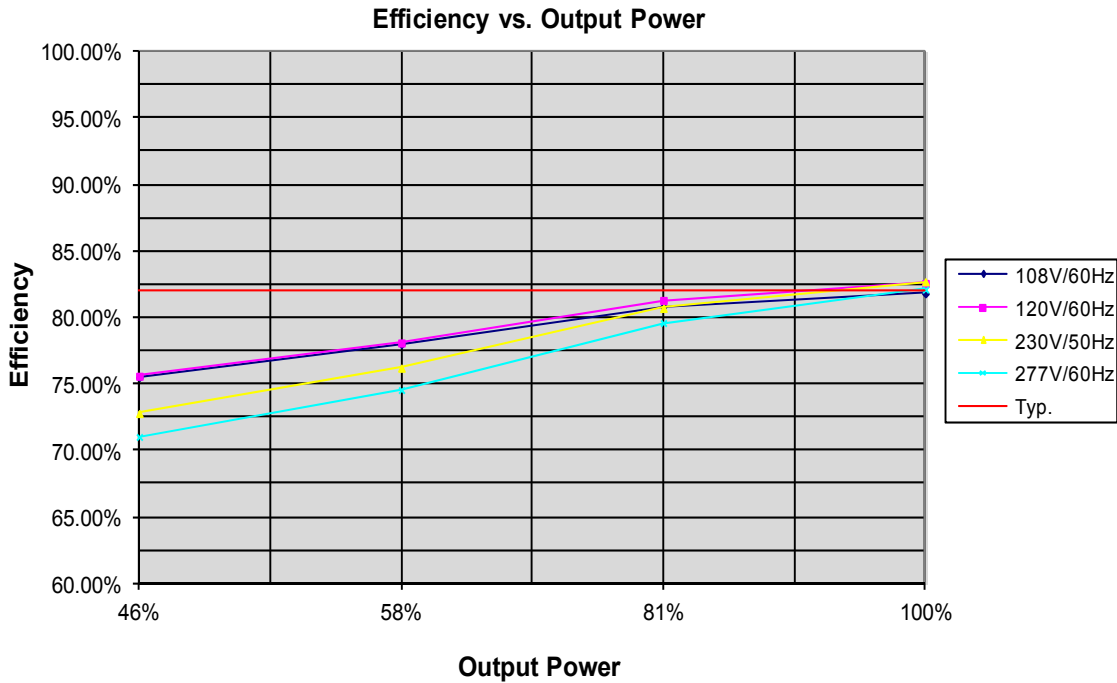

# 40 Watt - LP40W-56-PC1500-RD

FLICKER FREE PROGRAMMABLE LED DRIVER WITH 0-10V DIMMING & 12V AUX

## Power Operating Window

**POWER OPERATING WINDOW**  
Vout (Vdc) vs. Output Current (mA)

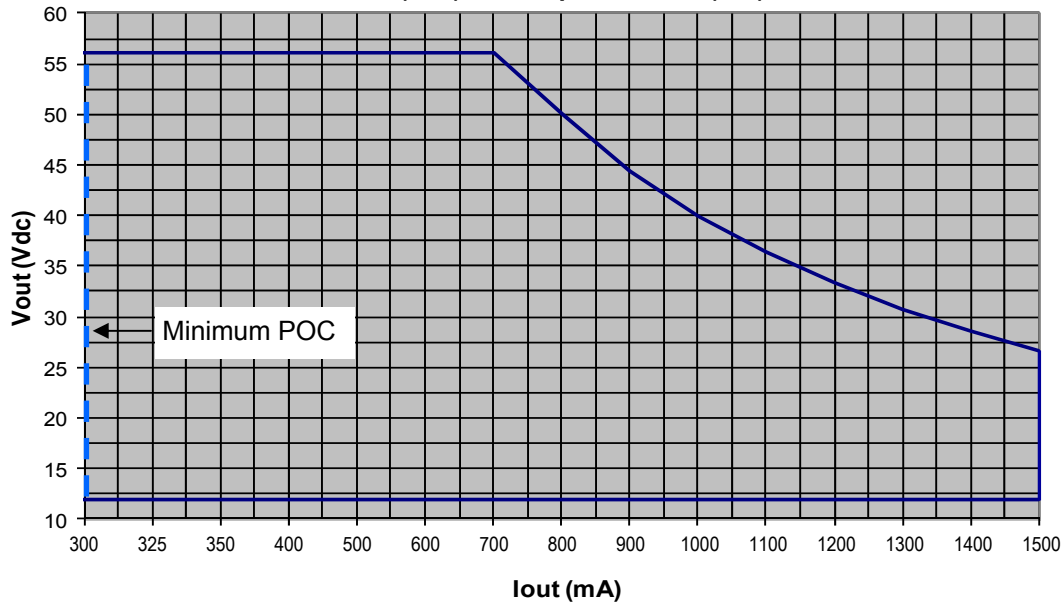

## POC (Programmable Output Current)

POC Setting: If Rset is open, EP Programmer GUI can be used to set Iout. Output Current vs. Rset or GUI value is within  $\pm 5\%$ . Rset can be any  $\geq 1/4W$ ,  $\pm 1\%$ ,  $\geq 20V$  rated resistor.  
<sup>(1)</sup> Rset >9,900 Ohms will default Iout to GUI setting.

Rset <sup>(1)</sup> (Ohms)	Iout (mA)
208	150
210	154
229	160
270	180
320	200
395	230
443	250
570	300
705	350
845	400
994	450
1150	500
1490	600
1870	700
2300	800
2790	900
3345	1000
3655	1050
5200	1250
5680	1300
6210	1350
6800	1400
7460	1450
8200	1500
9800	1500
10000 <sup>(1)</sup>	GUI SET <sup>(1)</sup>

**Output Current (mA) vs. Rset (Ohms)**

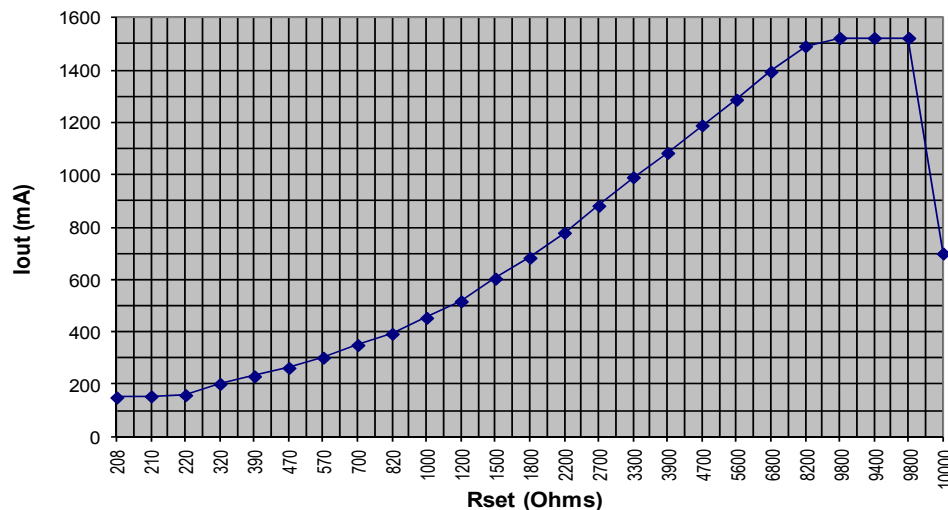



## 40 Watt - LP40W-56-PC1500-RD

FLICKER FREE PROGRAMMABLE LED DRIVER WITH 0-10V DIMMING & 12V AUX

### 1% EIA E96 Standard Resistor Values vs. Iout

1% EIA E96 Standard Resistor values vs. Calculated Output Current Nominal Value

Rset (Ohms)	POC Iout (mA)	Rset (Ohms)	POC Iout (mA)	Rset (Ohms)	POC Iout (mA)	Rset (Ohms)	POC Iout (mA)	Rset (Ohms)	POC Iout (mA)	Rset (Ohms)	POC Iout (mA)
210	150.9	383	225.1	698	347.5	1270	537.0	2320	805.4	4870	1212.7
215	153.2	392	228.8	715	353.7	1300	545.9	2370	816.2	4990	1226.6
221	155.8	402	232.9	732	359.9	1330	554.8	2430	829.0	5110	1240.1
226	158.0	412	237.0	750	366.4	1370	566.5	2490	841.5	5230	1253.3
232	160.7	422	241.0	768	372.8	1400	575.2	2550	853.9	5360	1267.2
237	162.9	432	245.1	787	379.6	1430	583.7	2610	866.1	5490	1280.7
243	165.5	442	249.1	806	386.3	1470	595.1	2670	878.0	5620	1293.9
249	168.1	453	253.6	825	393.0	1500	603.4	2740	891.7	5760	1307.8
255	170.7	464	258.0	845	399.9	1540	614.5	2800	903.3	5900	1321.2
261	173.3	475	262.4	866	407.2	1580	625.4	2870	916.5	6040	1334.4
267	175.9	487	267.2	887	414.4	1620	636.2	2940	929.5	6190	1348.0
274	179.0	499	271.9	909	421.9	1650	644.2	3010	942.3	6340	1361.3
280	181.6	511	276.6	931	429.3	1690	654.8	3090	956.6	6490	1374.2
287	184.6	523	281.3	953	436.7	1740	667.8	3160	968.9	6650	1387.6
294	187.6	536	286.4	976	444.3	1780	678.1	3240	982.6	6810	1400.7
301	190.6	549	291.4	1000	452.2	1820	688.2	3320	996.1	6980	1414.1
309	194.0	562	296.5	1020	458.8	1870	700.7	3400	1009.4	7150	1427.2
316	197.0	576	301.8	1050	468.5	1910	710.6	3480	1022.3	7320	1439.8
324	200.4	590	307.2	1070	475.0	1960	722.8	3570	1036.6	7500	1452.8
332	203.8	604	312.5	1100	484.5	2000	732.4	3650	1049.1	7680	1465.5
340	207.1	619	318.2	1130	494.0	2050	744.3	3740	1062.8	7870	1478.4
348	210.5	634	323.8	1150	500.3	2100	755.9	3830	1076.2	8060	1490.9
357	214.2	649	329.4	1180	509.6	2150	767.5	3920	1089.3	8200	1500.0
365	217.6	665	335.4	1210	518.8	2210	781.1	4640	1185.2	10000	GUI SET
374	221.3	681	341.3	1240	528.0	2260	792.2	4750	1198.5		

### 1% Resistor Color Codes:

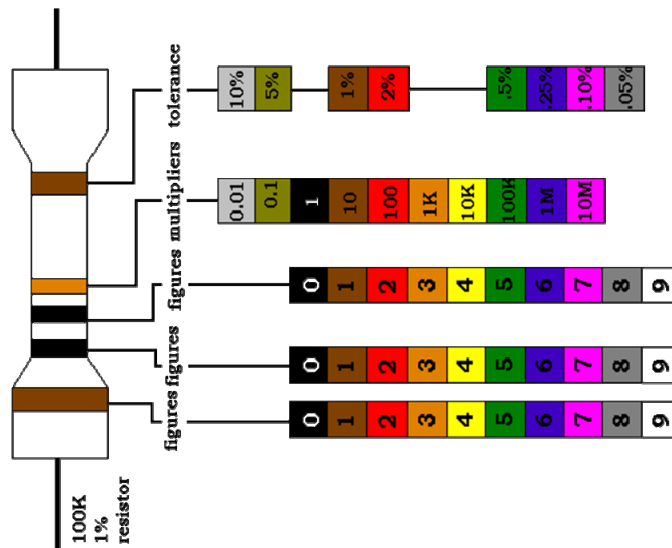

# 40 Watt - LP40W-56-PC1500-RD

FLICKER FREE PROGRAMMABLE LED DRIVER WITH 0-10V DIMMING & 12V AUX

## Module Temperature Protection using External NTC

**Example:** NTC High, NTC Low and NTC Minimum Iout% can be programmed using EP Programmer USB interface & EPtronics PC based GUI Software.

Factory Default Settings: NTC Low = 2.0K  $\approx$  10% Iout, NTC High = 6.3K, 100% Iout

Programmable settings: NTC Minimum Level (%), NTC Minimum Ohms, NTC Maximum Ohms.

Output Current (%) vs. NTC (Ohms)

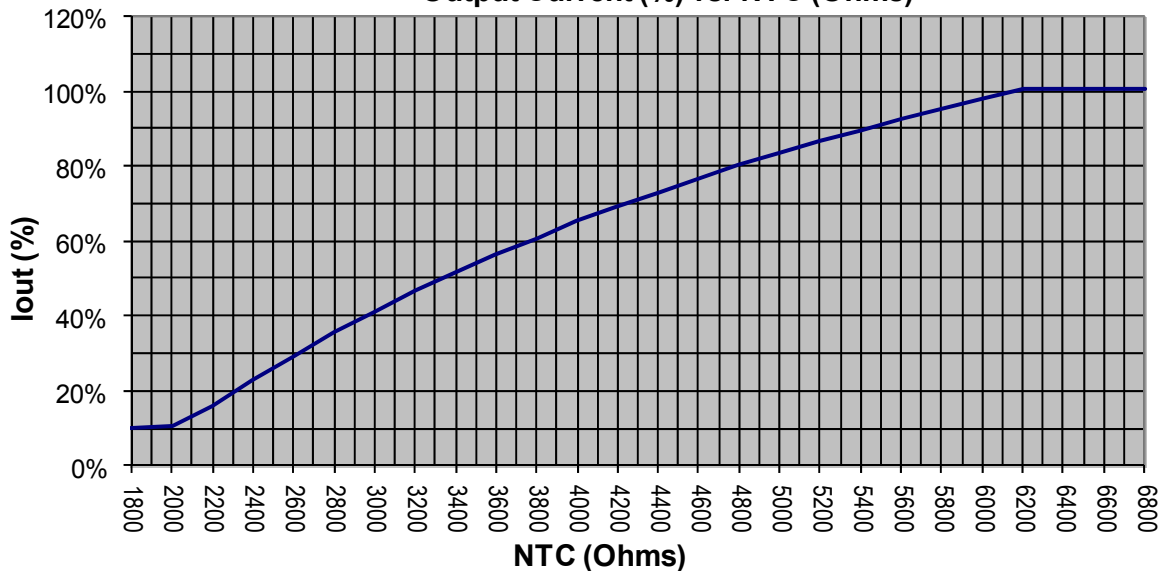

## Module Temperature Protection Example

NTC = 805SMD,  $R_{25C} = 15K \text{ Ohm} \pm 2\%$ ,  $R_{64C} = 3700$ , Vishay Part#: NTCS0805E3153GMT

With part set: NTC Max = 6.3K, NTC MIN = 2.0K, Iout Min = 10%

Output Current (%) vs. NTCS0805E3153GMT NTC Temp ( $^{\circ}C$ )

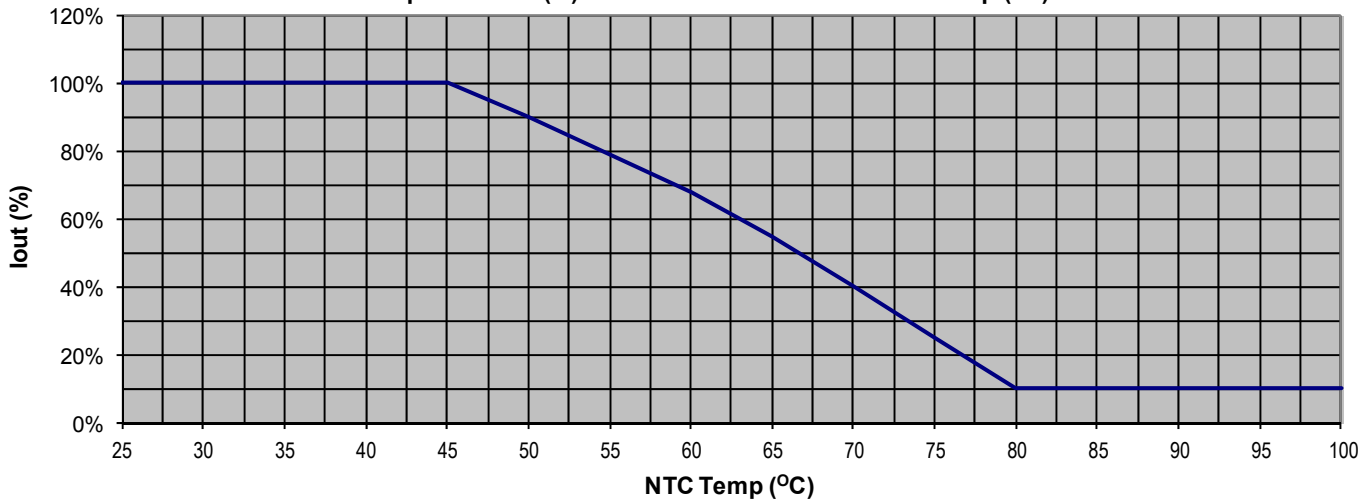

## 40 Watt - LP40W-56-PC1500-RD

FLICKER FREE PROGRAMMABLE LED DRIVER WITH 0-10V DIMMING & 12V AUX

### EP Programmer PC Based Software , USB Interface

**Programmable Output Current (POC):** Programmable lout from 300mA to 1500 mA

**Programmable NTC settings:** NTC Minimum Level (%), NTC Minimum Ohms, NTC Maximum Ohms.

Factory Default: NTC Minimum = 2.0K,  $\approx$  10% lout, NTC Maximum = 6.3K, 100% lout

**Programmable dimming curve:** Linear or LOG

Factory Default: Linear Dimming Curve

**Programmable Minimum Dim Level:** 0% (OFF) to 100% lout programmed value.

Factory Default: Min dim level 0%

### EPtronics Programming Tool:

The EP Programmer is a programming and configuration tool for EPtronics intelligent programmable LED drivers. It consists of the EP programming Interface (EP-PRG-01) which is connected between the USB port of a computer and the LED driver being programmed, and the EP programmer software. The EP programmer software is a PC based graphical user interface that allows the user to program and configure the operating parameters of an EPtronics Programmable LED Driver. This interface allows the operator to set the LED drivers output current within its specified range, in the increments specified. It also provides the ability to enable/disable and control features like "Dimming", "Auxiliary Output", "NTC Thermal Protection", "Constant Lumen Module" & "End-of-life indicator" when available in the EPtronics intelligent LED driver being programmed.

### EP Programming Interface: (EP-PRG-01)

Is the physical USB unit connected between the USB port of a computer and the LED driver being programmed. This unit also provides all power required to the LED driver being programmed. No connection to an AC power source is required for programming the LED driver.

### EP Programmer Software:

The EP Programmer software is the windows based GUI that allows the user to assign custom part number(s) to the LED driver being programmed. The user can then save the profile to a computer disk and recall as needed. The user can then use the "Auto Program" feature to quickly program as many LED drivers with the saved profile as is required. Each driver programming simply requires a click of the mouse to program in a single step.

The EP Programmer software supports bar code scanners. The barcode scanner can be used to automate the programming of the attached LED driver. This barcode scanner interface also provides an option to either enable or disable logging of the parameters to an excel file.

*Note: The programming of the LED driver does not require the input be connected to an AC power connection. The EP Programmer and the required LED driver circuitry will be powered from the EP Programmer module via the USB connection to a computer.*

**For new GUI settings to take effect the AC input must cycled off/on and the USB interface disconnected.**

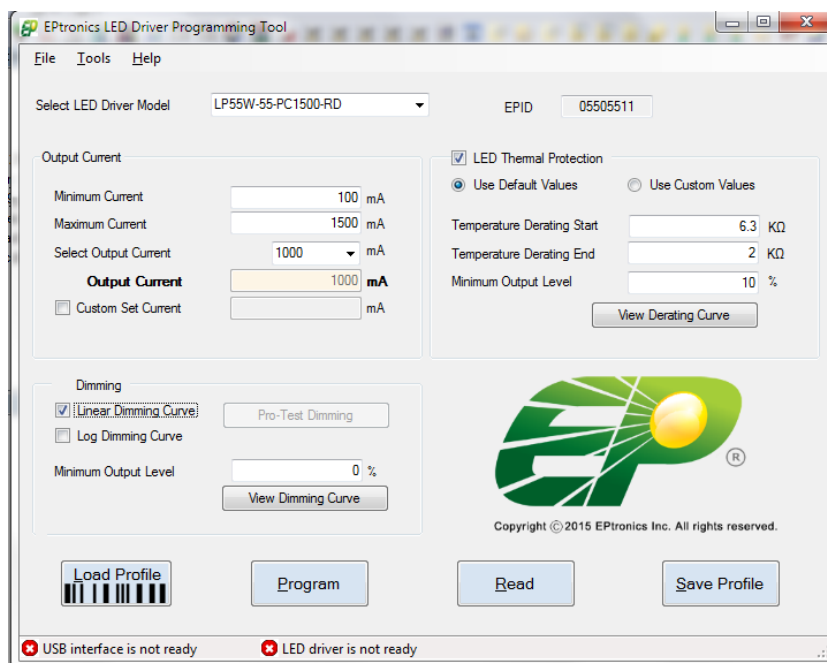

# 40 Watt - LP40W-56-PC1500-RD

FLICKER FREE PROGRAMMABLE LED DRIVER WITH 0-10V DIMMING & 12V AUX

## Life vs. Case (Tc) Temperature

