



US009942604B2

(12) **United States Patent**
Braithwaite et al.

(10) **Patent No.:** **US 9,942,604 B2**
(45) **Date of Patent:** ***Apr. 10, 2018**

(54) **LEGACY CONVERTER**

(71) Applicant: **Netstreams, LLC**, Salt Lake City, UT (US)

(72) Inventors: **Michael Braithwaite**, Austin, TX (US);
Herman Cardenas, Georgetown, TX (US)

(73) Assignee: **Netstreams, LLC**, Salt Lake City, UT (US)

(*) Notice: Subject to any disclaimer, the term of this patent is extended or adjusted under 35 U.S.C. 154(b) by 0 days.

This patent is subject to a terminal disclaimer.

(21) Appl. No.: **15/481,590**

(22) Filed: **Apr. 7, 2017**

(65) **Prior Publication Data**

US 2017/0214968 A1 Jul. 27, 2017

Related U.S. Application Data

(60) Continuation of application No. 15/099,081, filed on Apr. 14, 2016, which is a continuation of application (Continued)

(51) **Int. Cl.**

H04L 12/28 (2006.01)

G06F 17/00 (2006.01)

(Continued)

(52) **U.S. Cl.**

CPC ... **H04N 21/43615** (2013.01); **H04L 12/2801** (2013.01); **H04L 65/4076** (2013.01);

(Continued)

(58) **Field of Classification Search**

CPC H04N 21/233; H04N 21/2343; H04N 21/43615; H04N 21/4402; H04N 21/4398;

(Continued)

(56) **References Cited**

U.S. PATENT DOCUMENTS

4,525,746 A 6/1985 Mangold et al.
4,888,811 A 12/1989 Takashi

(Continued)

FOREIGN PATENT DOCUMENTS

AU 2003241405 A1 11/2003
AU 2003241405 B2 6/2008

(Continued)

Primary Examiner — Xu Mei

(74) Attorney, Agent, or Firm — Matthew J. Booth PC; Matthew J. Booth

(57) **ABSTRACT**

The present disclosure describes a legacy converter for an audio distribution system that uses a local area network where the legacy converter converts a digital audio signal to and from an analog audio signal and provides an external bridge connection between the audio system and one or more legacy sources and one or more legacy control networks. The legacy converter includes a network controller where the network controller further includes an embedded controller with memory and which is programmed to function as a web server. In addition, the legacy converter includes a network interface, an audio format converter that includes one or more audio encoders to provide multiple conversions of different legacy audio inputs simultaneously, an analog to digital converter, a legacy controller, a legacy audio network interface that bridges the legacy sources, and, a legacy control network interface.

28 Claims, 12 Drawing Sheets

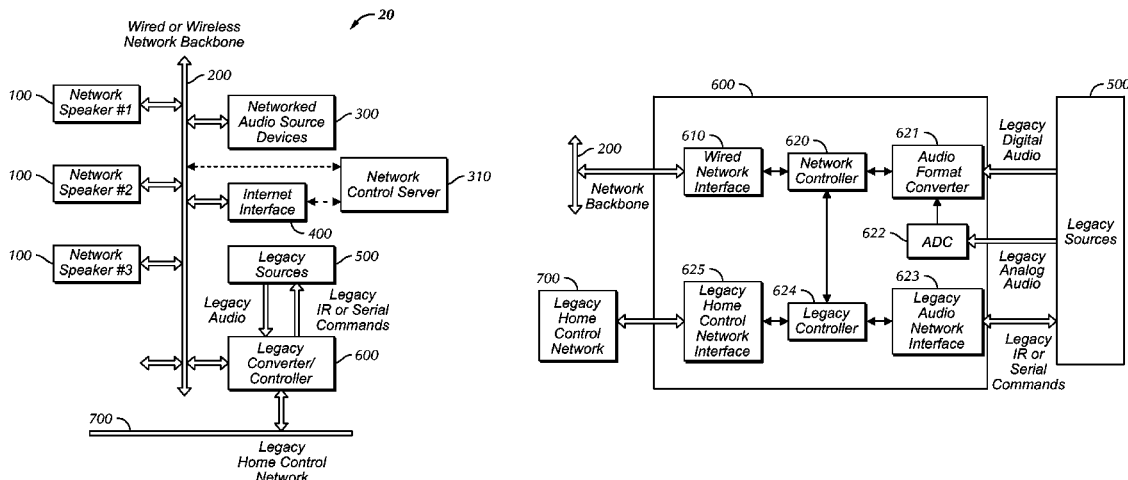

Related U.S. Application Data

No. 13/078,289, filed on Apr. 1, 2011, now Pat. No. 9,331,864, which is a division of application No. 12/015,385, filed on Jan. 16, 2008, now Pat. No. 8,725,277, which is a continuation of application No. 10/513,737, filed as application No. PCT/US03/14603 on May 8, 2003, now Pat. No. 7,643,894.

(60) Provisional application No. 60/379,313, filed on May 9, 2002.

(51) **Int. Cl.**

H04N 21/436 (2011.01)
H04L 29/08 (2006.01)
H04L 29/06 (2006.01)
H04N 21/422 (2011.01)
H04N 21/439 (2011.01)
H04N 21/4402 (2011.01)
H04N 21/233 (2011.01)
H04N 21/2343 (2011.01)
G06F 17/30 (2006.01)

(52) **U.S. Cl.**

CPC **H04L 67/10** (2013.01); **H04N 21/233** (2013.01); **H04N 21/2343** (2013.01); **H04N 21/42203** (2013.01); **H04N 21/4398** (2013.01); **H04N 21/4402** (2013.01); **G06F 17/30743** (2013.01)

(58) **Field of Classification Search**

CPC H04N 21/42203; H04L 65/4076; H04L 67/10
 USPC 700/94; 381/55, 58, 59, 77, 80, 82, 85
 See application file for complete search history.

(56) **References Cited**

U.S. PATENT DOCUMENTS

5,402,499 A 3/1995 Robison et al.
 5,406,634 A 4/1995 Anderson et al.
 5,519,641 A 5/1996 Beers et al.
 5,544,228 A 8/1996 Wagner et al.
 5,588,065 A 12/1996 Tanaka et al.
 D385,880 S 11/1997 Oba
 5,722,041 A 2/1998 Freadman
 5,729,611 A 3/1998 Bonneville
 5,742,690 A 4/1998 Edgar
 5,799,042 A 8/1998 Xiao
 5,822,440 A 10/1998 Oltman et al.
 5,832,024 A 11/1998 Schotz et al.
 5,903,135 A 5/1999 Posses et al.
 5,946,343 A 8/1999 Schotz et al.
 6,064,699 A 5/2000 Law
 6,085,236 A 7/2000 Lea
 6,101,180 A 8/2000 Donahue et al.
 6,108,625 A 8/2000 Kim
 6,122,382 A 9/2000 Iida et al.
 6,185,305 B1 2/2001 Reinold et al.
 6,263,503 B1 7/2001 Margulis
 6,315,666 B1 11/2001 Mastera et al.
 6,327,477 B1 12/2001 Hachimura et al.
 6,327,563 B1 12/2001 Takagi
 6,329,908 B1 12/2001 Frecska

6,378,010 B1 4/2002 Burks
 6,574,234 B1 6/2003 Myer et al.
 6,682,472 B1 1/2004 Davis
 6,826,283 B1 11/2004 Wheeler et al.
 6,907,458 B2 6/2005 Tomassetti et al.
 6,934,300 B2 8/2005 Tomassetti et al.
 7,039,193 B2 5/2006 Mantegna et al.
 7,050,971 B1 5/2006 Kaufholz
 7,073,011 B2 7/2006 Lisitsa et al.
 7,181,299 B2 2/2007 Osakabe et al.
 7,200,644 B1 4/2007 Flanagan
 7,206,404 B2 4/2007 Parry et al.
 7,643,894 B2 1/2010 Braithwaite et al.
 8,131,389 B1 3/2012 Hardwick et al.
 8,131,390 B2 3/2012 Braithwaite et al.
 8,725,277 B2 5/2014 Braithwaite et al.
 9,137,035 B2 9/2015 Braithwaite et al.
 9,191,231 B2 11/2015 Braithwaite et al.
 9,191,232 B2 11/2015 Braithwaite et al.
 9,331,864 B2 5/2016 Braithwaite et al.
 2001/0005174 A1 6/2001 Olson et al.
 2002/0026541 A1 2/2002 Suzuki et al.
 2002/0059425 A1 5/2002 Belfiore et al.
 2002/0065568 A1 5/2002 Silfvast et al.
 2002/0072816 A1 6/2002 Shdema et al.
 2002/0072817 A1 6/2002 Champion
 2002/0075965 A1 6/2002 Claesson et al.
 2002/0077114 A1 6/2002 Isham
 2002/0082730 A1 6/2002 Capps et al.
 2002/0087224 A1 7/2002 Barile
 2002/0186662 A1 12/2002 Tomassetti et al.
 2002/0188752 A1 12/2002 Tomassetti et al.
 2002/0188762 A1 12/2002 Tomassetti et al.
 2003/0014486 A1 1/2003 May
 2003/0023741 A1 1/2003 Tomassetti et al.
 2003/0028584 A1 2/2003 Coniglio et al.
 2005/0076134 A1 4/2005 Bialik et al.
 2005/0131558 A1 6/2005 Braithwaite et al.
 2006/0287746 A1 12/2006 Braithwaite et al.
 2008/0109095 A1 5/2008 Braithwaite et al.
 2008/0114481 A1 5/2008 Braithwaite et al.
 2009/0193472 A1 7/2009 Braithwaite et al.
 2010/0172512 A1 7/2010 Braithwaite et al.
 2010/0303046 A1 12/2010 Braithwaite
 2011/0044468 A1 2/2011 Braithwaite et al.
 2011/0044469 A1 2/2011 Braithwaite et al.
 2011/0185389 A1 7/2011 Braithwaite et al.
 2017/0013304 A1 1/2017 Braithwaite et al.
 2017/0332132 A1 11/2017 Braithwaite et al.

FOREIGN PATENT DOCUMENTS

AU 2008207498 A1 9/2008
 AU 2008207498 B2 9/2008
 AU 2008207498 B2 9/2011
 AU 2011211407 A1 11/2012
 AU 2011211407 B2 11/2012
 CA 2485104 11/2003
 EP 1098548 A2 5/2001
 EP 1146775 A2 10/2001
 EP 1504367 2/2005
 GB 2199466 7/1988
 KR 10-2005-0005472 A1 1/2005
 KR 100966415 B1 6/2010
 WO 2002/091596 A2 11/2002
 WO WO03096741 11/2003
 WO 2003/096741 A3 4/2004

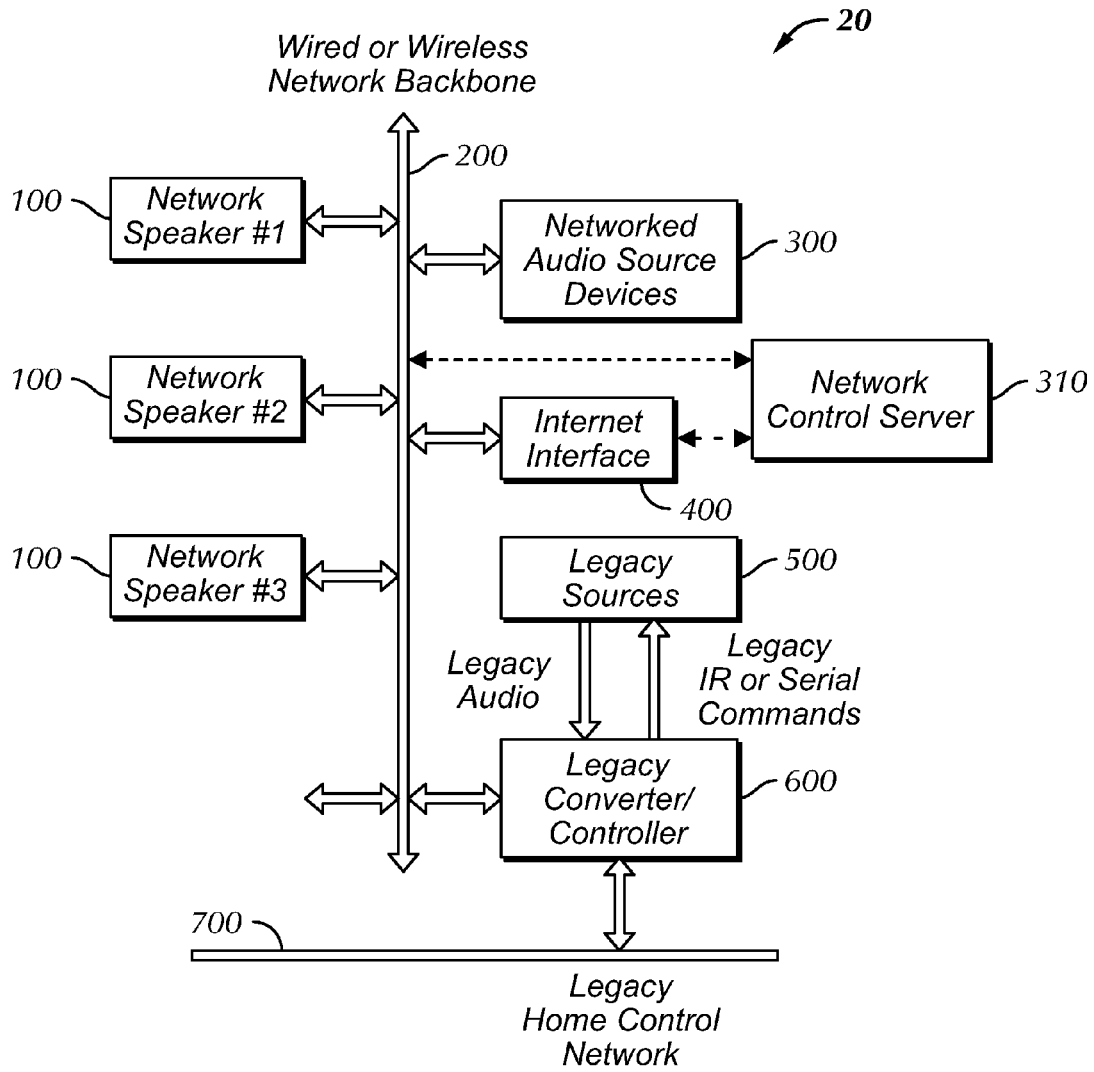

FIG. 1

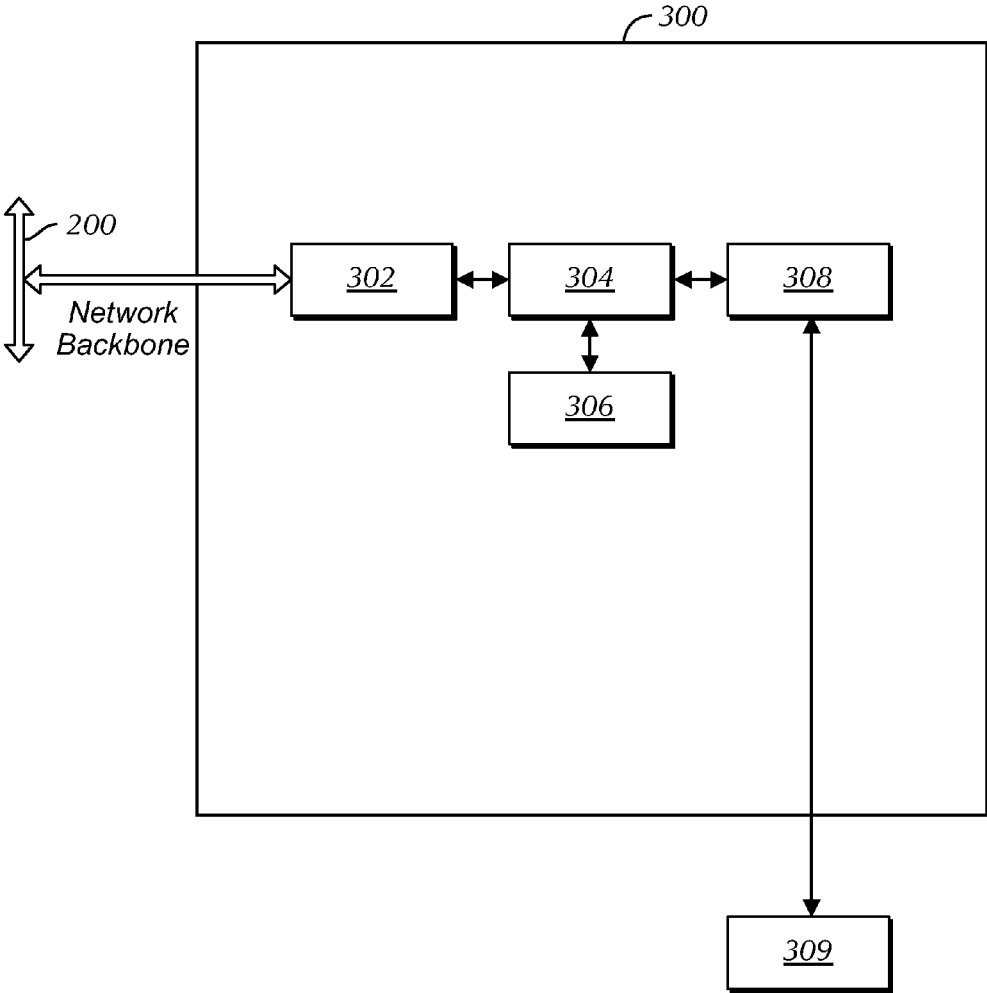

FIG. 2A

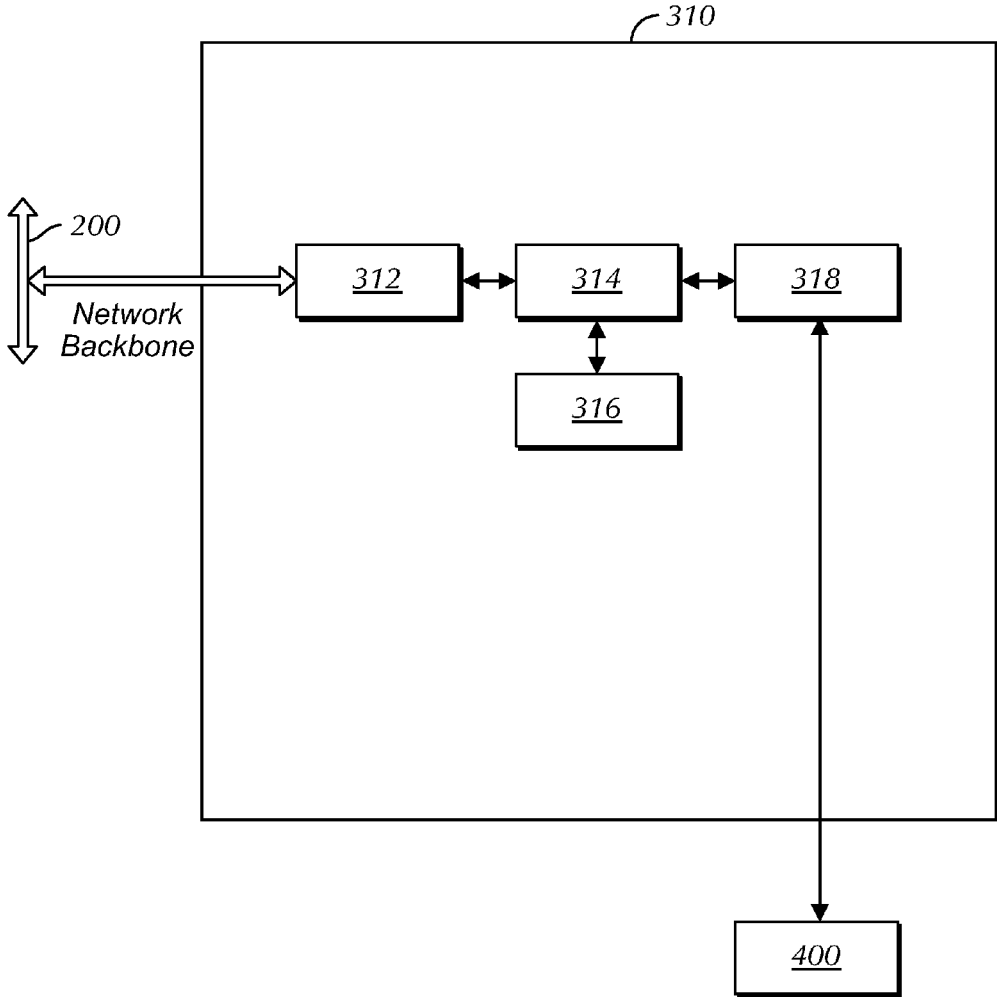

FIG. 2B

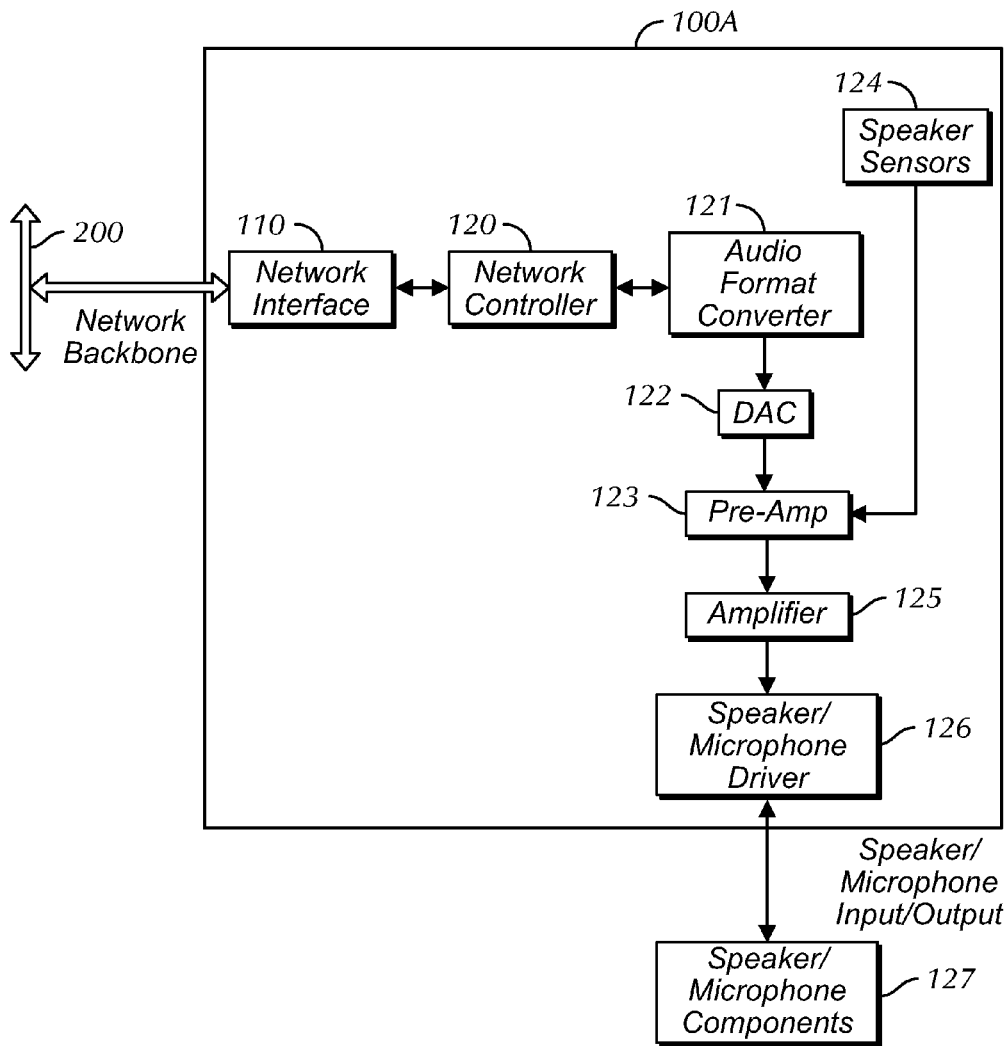

FIG. 3

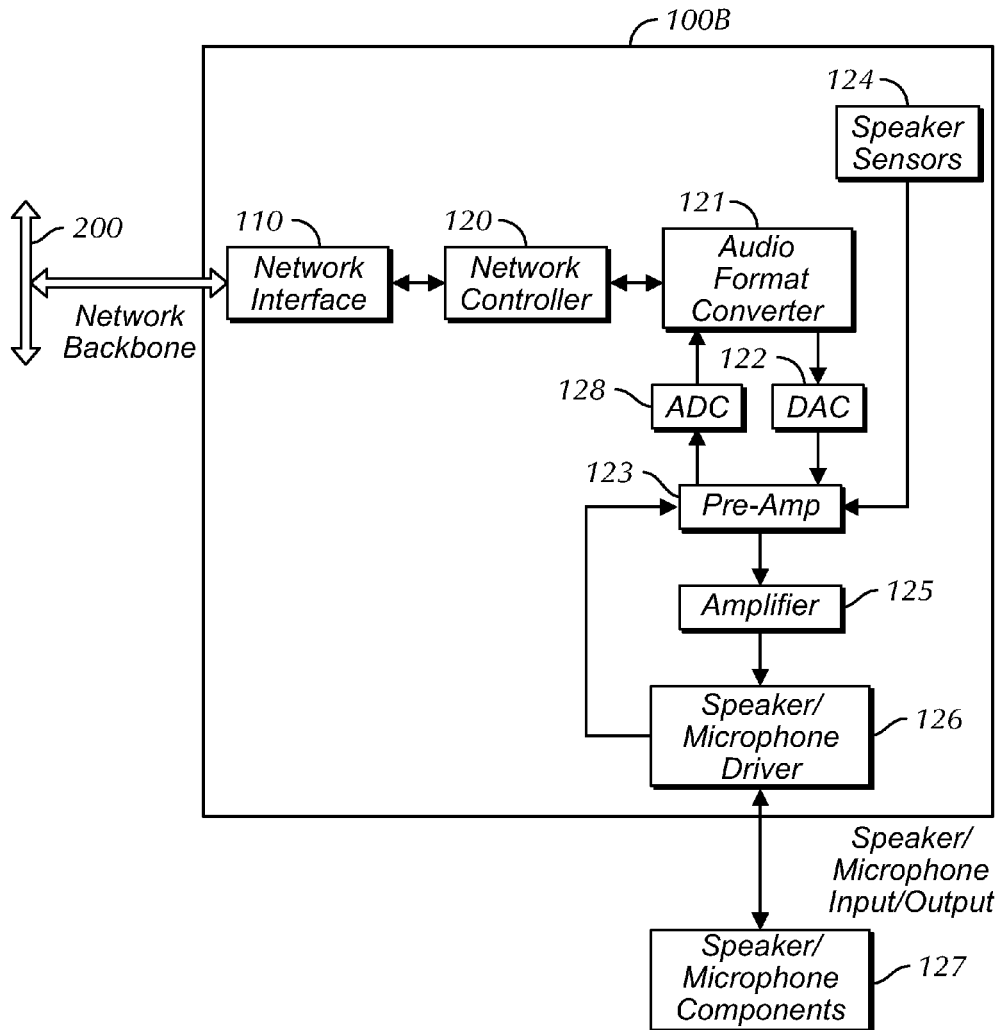

FIG. 4A

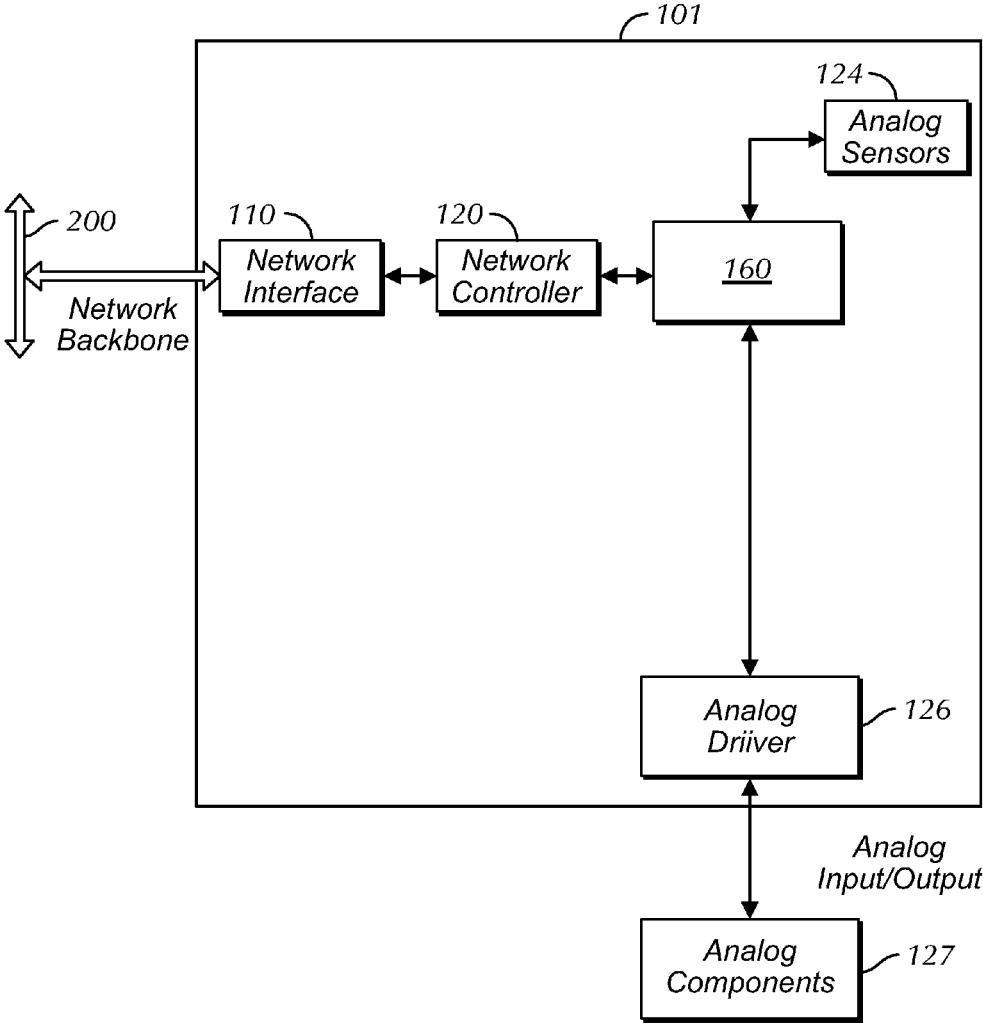

FIG. 4B

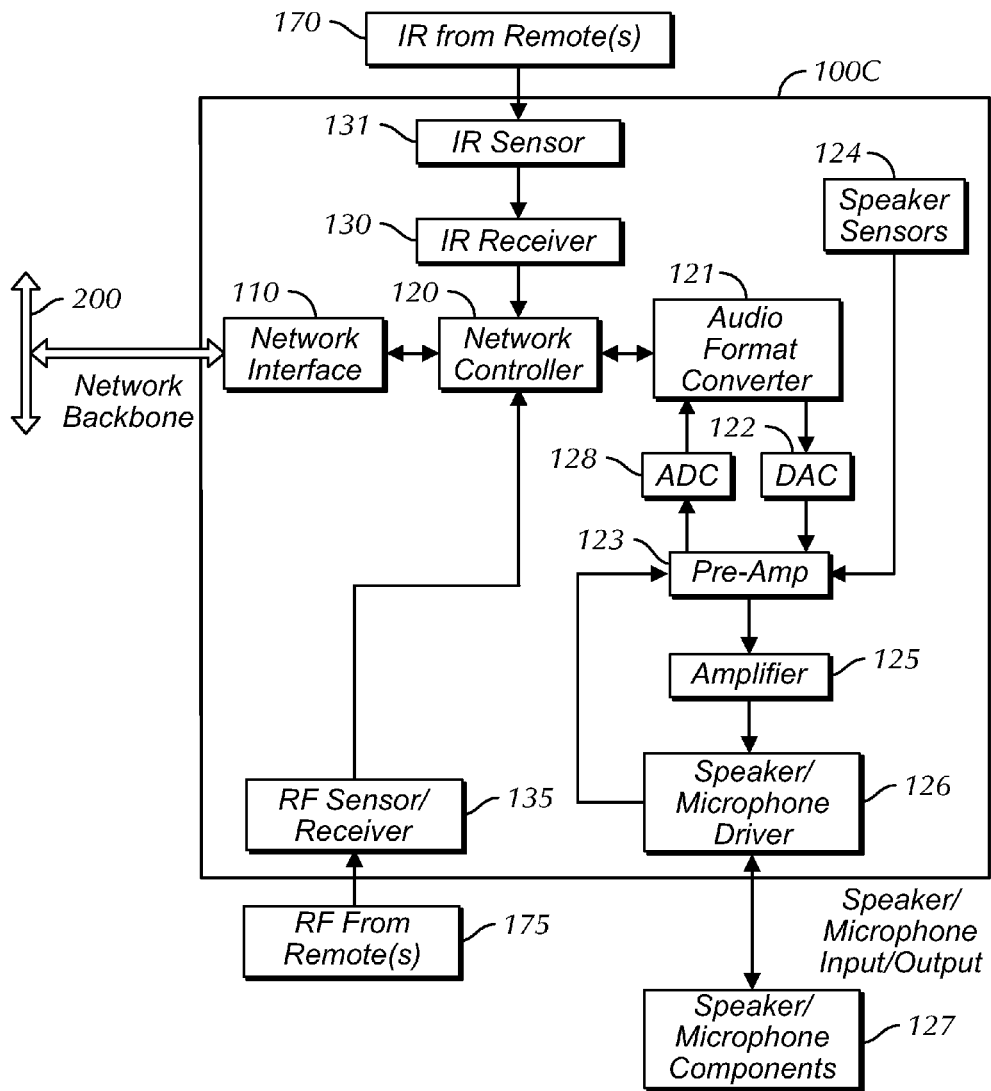

FIG. 5

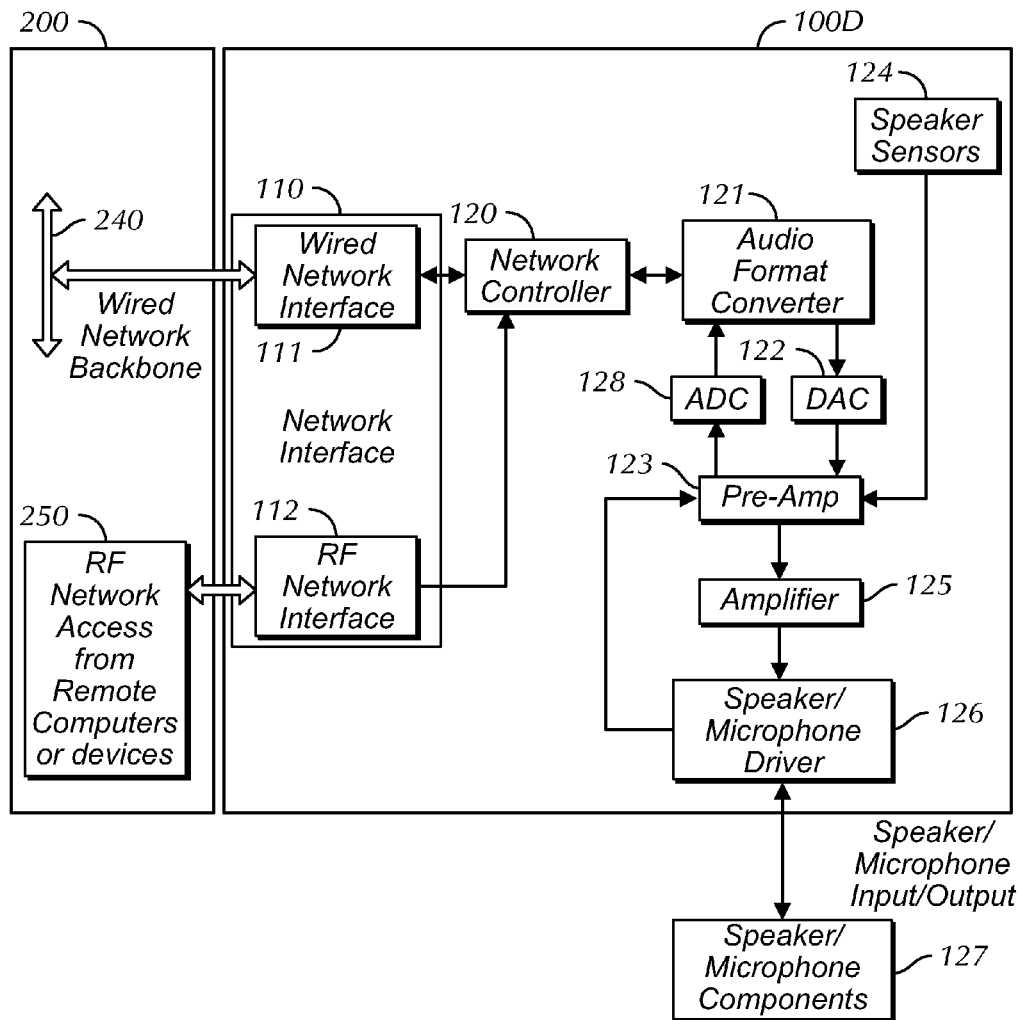

FIG. 6

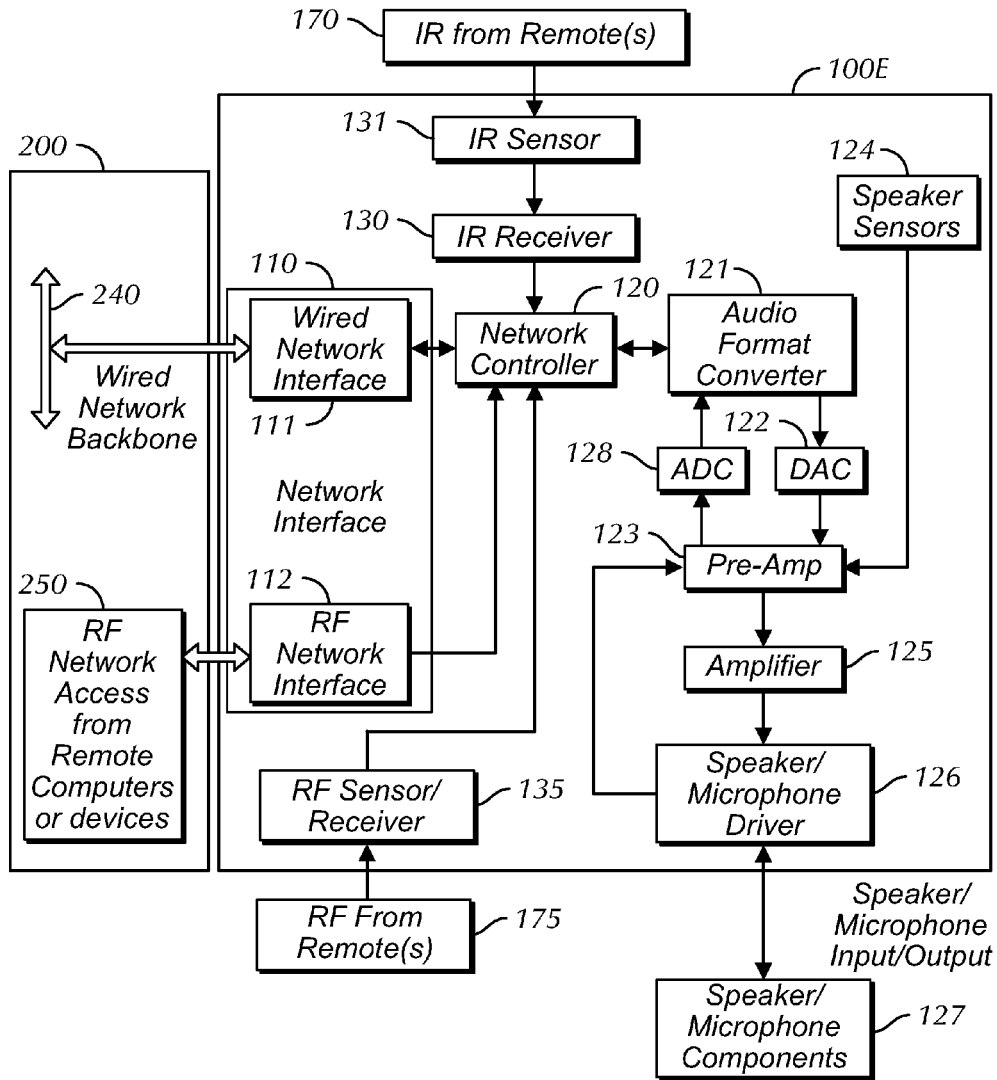

FIG. 7

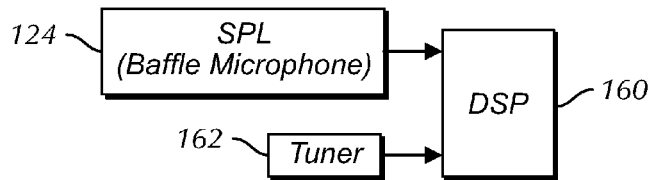

FIG. 8

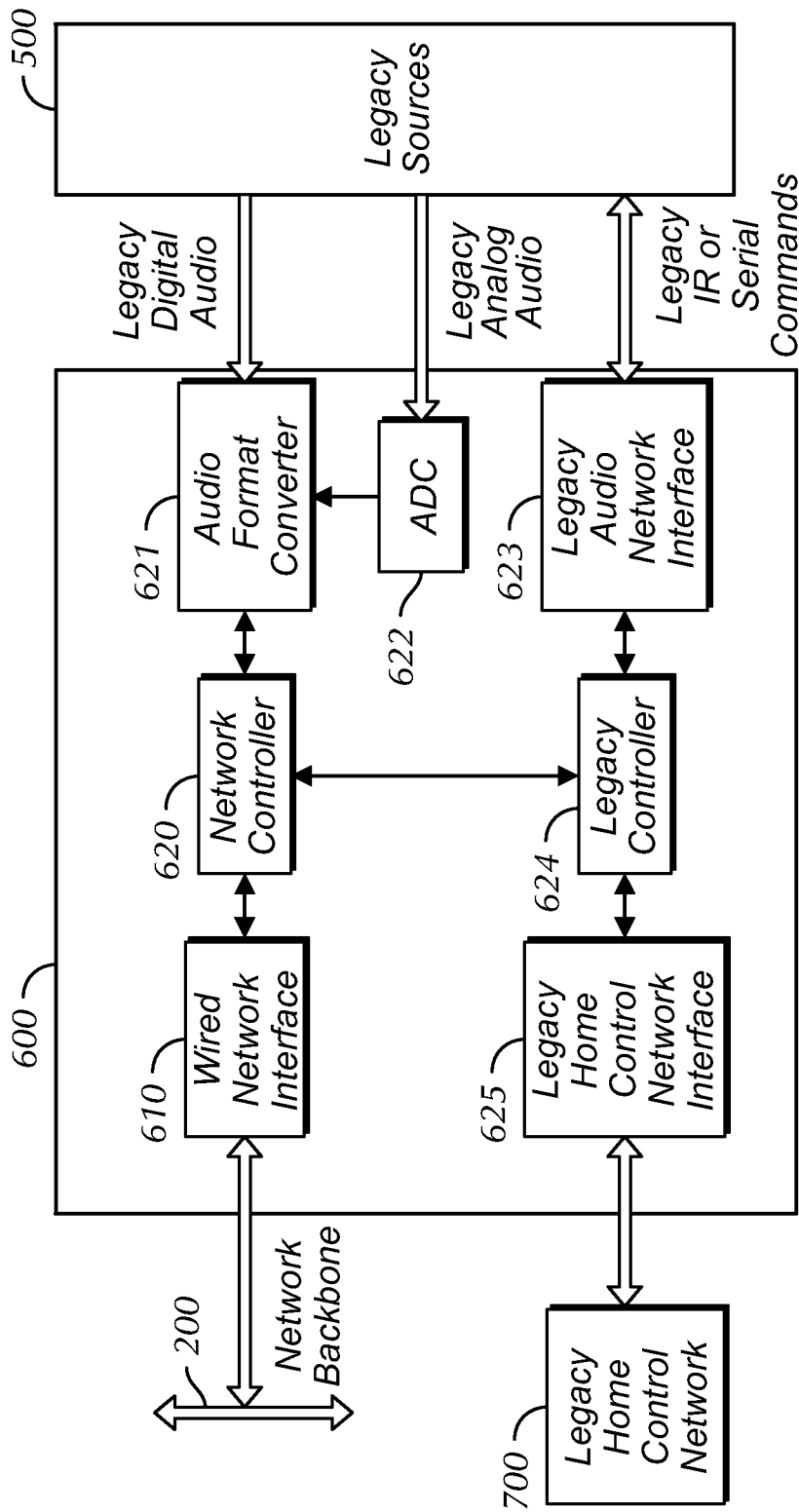

FIG. 9

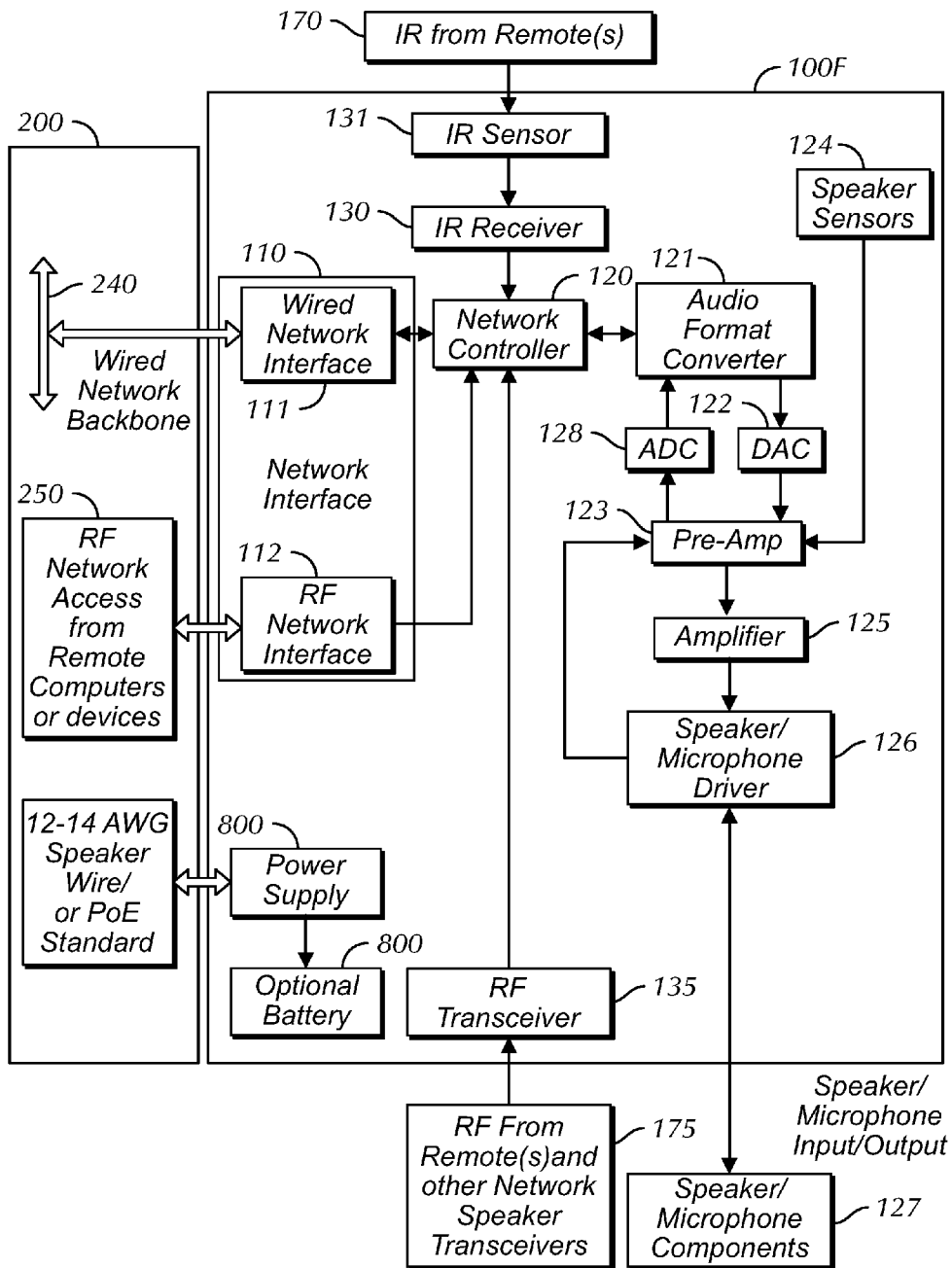

FIG. 10

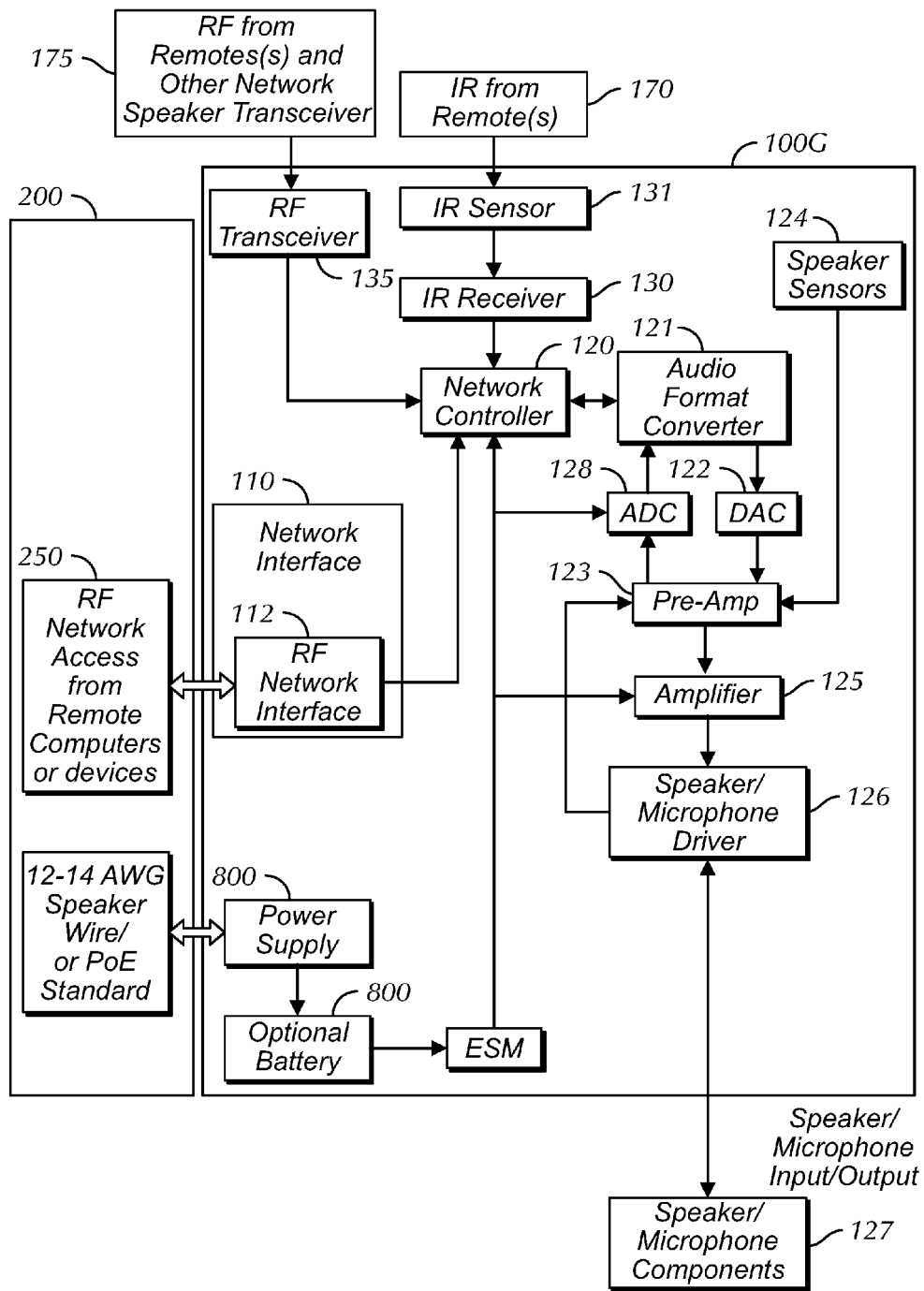

FIG. 11

LEGACY CONVERTER**CROSS REFERENCE TO RELATED APPLICATIONS**

This application claims the benefits of the earlier filed U.S. Provisional Application Ser. No. 60/379,313, filed 9 May 2002, which is incorporated by reference for all purposes into this specification.

Additionally, this application is a continuation of International Patent Application PCT/US2003/014603, filed 8 May 2003, which is incorporated by reference for all purposes into this specification.

Additionally, this application is a continuation of U.S. Ser. No. 10/513,737, filed 4 Nov. 2004, which is incorporated by reference for all purposes into this specification.

Additionally, this application is a divisional of U.S. Ser. No. 12/015,385, filed 16 Jan. 2008, which is incorporated by reference for all purposes into this specification.

Additionally, this application is a divisional of U.S. Ser. No. 13/078,289, filed 1 Apr. 2011, which is incorporated by reference for all purposes into this specification.

Additionally, this application is a continuation of U.S. Ser. No. 15/099,081, filed 14 Apr. 2016, which is incorporated by reference for all purposes into this specification.

TECHNICAL FIELD

The present invention relates to audio systems. More specifically, the present invention relates to audio video distribution systems.

BACKGROUND ART

Currently, most audio speakers are passive devices that receive an analog or digital audio signal. A few advanced models have limited self-diagnostics that can be communicated out over additional wire runs as well. These speakers are usually wired to racks or source switching pre-amps and amplifiers. The problem with this approach is that these systems are not very flexible. It is hard to expand the audio sources that can be heard through the speakers embedded in walls or other places after the system has been installed without buying and installing additional costly components. Other audio sources include as home control system voice communication, intercom audio, soundtracks for CD-ROM games, solid-state sound memories. Digital audio broadcasting systems, and even Internet audio can not easily be added and routed through to the existing speakers at a future date if the existing system was not originally designed to input and handle it. This is mostly due to the ongoing proliferation of new audio compression formats. High-quality digital audio data takes a lot of hard disk space to store (or channel bandwidth to transmit). Because of this many companies have worked on compressing and or coding of the bit stream to allow for a smaller binary footprint. This allows for high quality music to take up less storage space and to be transported across vast networks with a smaller amount of data, and therefore less bandwidth. However, these new compression and encoding formats require that un-compression and decoding be performed to reconstitute the original audio before it is played out the loudspeaker. If an existing audio system is limited to reconstituting only audio formats known at the time of installation, the audio system quickly becomes obsolete.

Many new products have wireless network capabilities, but still cannot be easily connected into a home network,

because of a lack of easily accessible wireless to wired network bridging within range of the device. This can especially be a problem if the wireless device is a handheld mobile unit such as a PDA, and due to a lack of access points, cannot communicate from all rooms in the house.

The current approach to controlling audio and doing home automation is often cumbersome. The sound system remote that allows the room audio level to be adjusted does not allow the room lights to be dimmed. Therefore, different remote controllers for each function are needed. Nor do users like the "wall clutter" created by putting separate multiple audio and other home network control units in the walls. Wireless solutions to this problem such as Radio Frequency, known as RF, or Infra-Red, called IR, have limitations. The biggest limitation for RF is that in many large cites, the RF noise background is very high, creating communication problems, and there may be health concerns with excessive RF. The IR limitation is that IR is effective in "line of sight" only, and the home automation devices to be controlled may be in other rooms. These problems are compounded in retrofit situations where die minimal changes that affect the current building and existing systems are desired.

One embodiment of the present disclosure is a networked speaker, so that an audio distribution system can be created that is integrated with the home automation system into a home network that permits vocal feedback, status, and even control with the audio through the network speakers. The network should let the user know what is happening, and provide very intuitive instruction on how to use the system. This will enable the audio speakers to easily adjust to and allow new audio sources and to become wireless access points in the home, or provide the wireless bridge to the hard-wired network.

SUMMARY OF INVENTION

The present disclosure describes a legacy converter for an audio distribution system that uses a local area network where the legacy converter converts a digital audio signal to and from an analog audio signal and provides an external bridge connection between the audio system and one or more legacy sources and one or more legacy control networks. The legacy converter includes a network controller that controls the processing of the digital audio signal to and from the audio distribution system on the local area network, where the network controller further includes an embedded controller with memory and which is programmed to function as a web server. In addition, the legacy converter includes a network interface that couples the network controller to the audio distribution system on the local area network. Further, the legacy converter includes an audio format converter that couples to the network controller and converts and formats the digital audio signal, where the audio format converter is updated through the local area network, and where the audio format converter includes one or more audio encoders to provide multiple conversions of different legacy audio inputs simultaneously. The legacy converter additionally includes an analog to digital converter that couples to the audio format converter and converts the analog audio signal from legacy sources to the digital audio signal. The legacy converter further includes a legacy controller that couples to the network controller and controls and communicates with legacy sources and or the legacy control network. In addition, the legacy converter includes a legacy audio network interface that bridges the legacy sources to said legacy controller. And, the legacy converter

includes a legacy control network interface that bridges the legacy control network to said legacy controller.

Additional embodiments of the legacy converter include a distributed clock signal. Further, the legacy audio network interface of the legacy converter may use a legacy communication method to communicate with the legacy sources. In addition, the legacy audio network interface may use a network communication method to communicate with the legacy sources. And further, the analog to digital converter may include a microphone connection to enable voice recognition and or voice control.

BRIEF DESCRIPTION OF DRAWINGS

To further aid in understanding the disclosure, the attached drawings help illustrate specific features and embodiments of the disclosure and the following is a brief description of the attached drawings:

FIG. 1 is a block diagram of an audio video distribution system.

FIG. 2A is a block diagram of a typical networked audio source device.

FIG. 2B is a block diagram of a typical network control server.

FIG. 3 is a block diagram of a network speaker embodiment.

FIG. 4A is a block diagram of another network speaker embodiment.

FIG. 4B is a block diagram of another network speaker embodiment.

FIG. 5 is a block diagram of another network speaker embodiment.

FIG. 6 is a block diagram of another network speaker embodiment.

FIG. 7 is a block diagram of another network speaker embodiment.

FIG. 8 is a block diagram of the internal components of a network speaker embodiment.

FIG. 9 is a block diagram of a Legacy Audio Converter/Controller.

FIG. 10 is a block diagram of a network speaker embodiment including power options.

FIG. 11 is a network speaker including battery powered options and an energy storage module.

DISCLOSURE OF EMBODIMENTS

The present disclosure describes a networked amplifier in an audio video distribution system. The disclosed embodiments are intended to describe aspects of the disclosure in sufficient detail to enable those skilled in the art to practice the invention. Other embodiments may be utilized and changes may be made without departing from the scope of the disclosure. The following detailed description is not to be taken in a limiting sense, and the scope of the present invention is defined only by the included claims.

Furthermore, specific implementations shown and described are only examples and should not be construed as the only way to implement or partition the present disclosure into functional elements unless specified otherwise herein. It will be readily apparent to one of ordinary skill in the art that the various embodiments of the present disclosure may be practiced by numerous other partitioning solutions.

In the following description, elements, circuits, and functions may be shown in block diagram form in order not to obscure the present disclosure in unnecessary detail. Additionally, block definitions and partitioning of logic between

various blocks is exemplary of a specific implementation. It will be readily apparent to one of ordinary skill in the art that the present disclosure may be practiced by numerous other partitioning solutions. Those of ordinary skill in the art would understand that information and signals may be represented using any of a variety of different technologies and techniques. For example, data, instructions, commands, information, signals, bits, symbols, and chips that may be referenced throughout the description may be represented by voltages, currents, electromagnetic waves, magnetic fields or particles, optical fields or particles, or any combination thereof. Some drawings may illustrate signals as a single signal for clarity of presentation and description. It will be understood by a person of ordinary skill in the art that the signal may represent a bus of signals, wherein the bus may have a variety of bit widths and the present disclosure may be implemented on any number of data signals including a single data signal.

The various illustrative hardware includes logical blocks, modules, and circuits described in connection with the embodiments disclosed herein may be implemented or performed with a general purpose processor, a special purpose processor, a Digital Signal Processor (DSP), an Application Specific Integrated Circuit (ASIC), a Field Programmable Gate Array (FPGA) or other programmable logic device, discrete gate or transistor logic, discrete hardware components, or any combination thereof designed to perform the functions described herein. A general purpose processor may be a microprocessor, any conventional processor, controller, microcontroller, or state machine. A general purpose processor may be considered a special purpose processor while the general purpose processor is configured to fetch and execute instructions (e.g., software code) stored on a computer readable medium such as any type of memory, storage, and/or storage devices. A processor may also be implemented as a combination of computing devices, such as a combination of a DSP and a microprocessor, a plurality of microprocessors, one or more microprocessors in conjunction with a DSP core, or any other such configuration.

In addition, the disclosed embodiments may be software or programs such as computer readable instructions that may be described in terms of a process that may be depicted as a flowchart, a flow diagram, a structure diagram, or a block diagram. The process may describe operational acts as a sequential process, many of these acts can be performed in another sequence, in parallel, or substantially concurrently. Further, the order of the acts may be rearranged. In addition, the software may comprise one or more objects, agents, threads, lines of code, subroutines, separate software applications, two or more lines of code or other suitable software structures operating in one or more software applications or on one or more processors.

Elements described herein may include multiple instances of the same element. These elements may be generically indicated by a numerical designator (e.g., 110) and specifically indicated by the numerical indicator followed by an alphabetic designator (e.g., 110A) or a numeric indicator preceded by a "dash" (e.g., 110-1). For ease of following the description, for the most part element number indicators begin with the number of the drawing on which the elements are introduced or most fully discussed. For example, where feasible elements in FIG. 3 are designated with a format of 3xx, where 3 indicates FIG. 3 and xx designates the unique element.

It should be understood that any reference to an element herein using a designation such as "first," "second," and so forth does not limit the quantity or order of those elements,

5

unless such limitation is explicitly stated. Rather, these designations may be used herein as a convenient method of distinguishing between two or more elements or instances of an element. Thus, a reference to first and second element does not mean that only two elements may be employed or that the first element must precede the second element in some manner. In addition, unless stated otherwise, a set of elements may comprise one or more elements.

FIG. 1 illustrates a block diagram of an audio video distribution system **20** (FIG. 1) includes a plurality of speaker node units **100** which are coupled to a Transport Control Protocol/Internet Protocol (TCP/IP) based network backbone **200**. Also coupled to the network backbone **200** are networked audio source node devices **300**, an Internet service interface **400**, and a Legacy converter/controller **600**. Legacy sources **500** provide analog or digital linear PCM (Pulse Coded Modulation) audio to be converted into a packet switched digital coding for transport across the network. They will also provide analog video which will be used for control status feedback, as well as conversion to a packet switched digital coding for transport across the network. In addition, the Legacy sources **500** will also receive IR or serial commands from the converter/controller **600** which also communicates with a Legacy home control network **700**. Some legacy sources **500** may also provide serial communications to the converter/controller **600**.

The networked audio source devices **300** can consist of any number of networked digital audio source devices (music playback devices) such as personal computers or audio servers that are able to communicate with one another over the shared TCP/IP network **200** and have the resources to serve digital audio files (WMA, MP3, Corona, etc.) to the network. Bit streamed audio (digital music, in the form of binary data that is sent in packets) from the Internet also may enter the system **20** from the Internet interface **400**. The Legacy audio devices **500** (existing analog audio equipment, i.e. CD players, tape decks, VCR's) have their audio converted into a packet switched digital network format (WMA, MP3, Corona) by the Legacy Converter **600** or by the network speakers **100**. The network speaker **100** can also real time encode sound received from its internal microphone or from reversing the transduction circuit from the speaker to perform the act of capturing sound waves present in the room, and then coding that sound and providing it for use on the network **20**, including by use of differential masking for control purposes. Any new device that is able to send audio out on the network can serve as the audio source for a network speaker **100** as long as the network speaker **100** understands the audio format. Control commands that affect the audio distribution can come from the network control server **310**, network audio source devices **300**, the Internet interface **400**, the legacy home control network **700** via the legacy converter/controller **600**, or from other network speakers **100**.

The system **20** is a collection of independent computers or other intelligent devices that communicate with one another over the shared TCP/IP network **200**. For example, the system **20** can be part of the Internet linked networks that are worldwide in scope and facilitate data communication services such as remote login, file transfer, electronic mail, the World Wide Web and newsgroups, or for security reasons part of a home intranet network utilizing Internet-type tools, but available only within that home. The home intranet is usually connected to the Internet via an Internet interface **400**. Intranets are often referred to as LANs (Local Area Networks).

6

The home network backbone **200** communicates using the TCP/IP network protocol consisting of standards that allow network members to communicate. A protocol defines how computers and other intelligent devices will identify one another on a network, the form that the data should take in transit, and how this information is processed once it reaches its final destination. Protocols also define procedures for handling lost or damaged transmissions or "packets". The TCP/IP network protocol is made up of layers of protocols, each building on the protocol layers below it. The basic layer is the physical layer protocol that defines how the data is physically sent through the physical communication medium, such as Thickwire, thin coax, unshielded twisted pair, fiber optic, telephone cable, fiber optic cable, RF, IR, power line wires, etc. Those physical media requiring an actual physical connection of some type, such as Thickwire, thin coax, unshielded twisted pair, fiber optic, power line, telephone cable, or fiber optic cable, to the network device are called wired media. Those physical media not requiring an actual physical wire connection of any type to the network device, such as RF and IR, are called wireless media. A TCP/IP home network can be totally wired, totally wireless, or a mix of wireless and wired. A TCP/IP home network is not limited to a single physical communication medium. Different physical communication media can be connected together by bridging components to create a unified communication network. Each network physical media has its physical layer protocol that defines the form that the data should take in transit on that particular physical media. The bridging component enables the transfer and conversion of communication on one physical medium and its physical layer protocol to a different physical media and its physical layer protocol. Bridging components also may provide a proxy from one network to the other, this will be common among UpnP V1 to V2, and with Ipv6 to Ipv4 (Internet Protocol version 6, 4). Common physical layer LAN technology in use today include Ethernet, Token Ring, Fast Ethernet, Fiber Distributed Data Interface (FDDI), Asynchronous Transfer Mode (ATM) and LocalTalk. Physical layer protocols that are very similar over slightly different physical media are sometimes referred to be the same name but of different type. An example are the three common types of Fast Ethernet: 100 BASE-TX for use with level 5 UTP cable, 100 BASE-FX for use with fiber-optic cable, and 100 BASE-T4 which utilizes an extra two wires for use with level 3 UTP cable. The TCP/IP protocol layers are well known and will not be further described in greater detail.

The system **20** may have any number of networked self-sufficient digital audio source devices **300** in it, such as a digital music storage device, PC, music player, personal Digital Assistant (PDA), on board automobile music system, digital integrated audio equipment, personal digital recorder or video digital recorder. Networked audio source devices **300** can provide digital audio files such as WMA, MP3, "Corona", and MLP from its hard disk, internal flash, or an audio input such as a microphone or CD reader or music player. The system **20** may also have any number of network control servers **310** that can encompass a specialized network server, usually a specialized, network-based hardware device designed to perform a single or specialized set of server functions. It is usually characterized by a minimal operating architecture, and client access that is independent of any operating system or proprietary protocol. Print servers, terminal servers, audio servers, control remote access servers and network time servers are examples of server devices which are specialized for particular functions. Often

these types of servers have unique configuration attributes in hardware or software that help them to perform best in their particular arena. While specialized hardware devices are often used to perform these functions in large systems, the specialized functions served by the network server could be performed by a more general use computer. A single computer, (sometimes referred to as a RISC (reduction instruction set computer), called a web server, could combine the functionality of the networked audio source devices **300** and the Internet interface **400**. If no connection to the Internet is desired, the Internet interface **400** function can be removed from the system without loss of intranet network integrity. Network and web servers are well known and will not be described in greater detail.

The legacy home control network **700** is an existing network of devices in the home used to automate and control the home. If the legacy home control network **700** cannot communicate over a shared TCP/IP network **200**, it cannot directly control or be controlled by the network speakers, and the two dissimilar networks must be bridged by a Legacy Converter/Controller **600**. Any legacy home control network **700** that can communicate within the system **20** over a shared TCP/IP network could be combined into the home network backbone **200** and then the legacy home control network **700** device would have access to and be able to control the network speaker **100** if it has the resources and instructions to do so. The Legacy Converter/Controller **600** can also be used to provide network access to un-networked legacy devices that are able to serve as command and control interfaces such as the telephone, cell phone, RF remote, IR remote, direct voice controller or keypad. A networked audio source **300** such as a PDA, also can act as the legacy converter/controller for a legacy device such as an attached cell phone.

The legacy home audio sources **500** are other audio sources that are not able to communicate over a shared TCP/IP network **200**, such as analog audio players, CD players, video game players, tape players, telephone, VCRs or other audio sources that are not able to communicate over a shared TCP/IP network **200**. The Legacy Converter/Controller **600** takes the analog or digital linear PCM audio from the Legacy home sources **500**, converts it into an acceptable digital format or formats if needed, and serves the audio as needed over the shared TCP/IP home network backbone **200**. If the legacy home audio source **500** provides an analog audio to the Legacy Converter/Controller **600**, the Legacy Converter/Controller **600** must convert the analog audio into an appropriate digital audio format before serving it to the network. The Legacy Converter/Controller **600** can also convert commands sent from the home network **200** to the legacy home source **500** into a command format that is understood by the legacy home source **500**, such as serial, RF or IR commands. A system may have multiple Legacy Converter/Controllers **600** for each legacy home source **500** or legacy home control network **700**, or a Legacy Converter/Controller **600** may convert and control more than one legacy home source **500** or multiple Legacy home control networks **700**.

FIG. 2A illustrates a typical self-sufficient networked audio source device **300** that can comprise any number of networked digital audio source devices such as music playback/storage devices, personal computers, audio servers such as a digital music storage device, PC, music player, personal Digital Assistant (PDA), on board automobile music system, digital integrated audio equipment, personal digital recorder or video digital recorder that are able to communicate with one another over the shared TCP/IP

network backbone **200** and have the resources to serve digital audio and/or video files to other devices on the network. The typical networked audio source device **300** includes a network interface **302** that couples the device **300** to the network backbone **200**. Operably coupled to the network interface **302** are one or more processors, memory, and storage **304** to perform all of the typical functions associated with the device **300**. In addition, the device **300** may comprise addition storage **306** such as a hard disk, a flash drive, or other type of storage device that is suitable for storage and playback of digital audio files or providing other functionality. A DSP **308** or similar circuitry is operably coupled to the processor **304** that provides the ability to convert digital analog and/or video signals to analog audio and/or video signals. DSP **308** is operably coupled to one or more analog components **309** that could include a microphone, speaker, or any other device that transmits or receives analog signals. One skilled in the art will appreciate that the functionality of DSP **308** can be combine with processor **304** such as found on a system-on-chip device. One skilled in the art will also appreciate that a single computer can combine the functionality of the networked audio source device **300** and the Internet interface **400**. Additionally, one skilled in the art will appreciate that a networked audio source device **300** also can act as a legacy converter/controller for a legacy device such as an attached cell phone. And further, control commands that affect the audio distribution in the system can come from the network audio source device **300**.

FIG. 2B illustrates a typical network control server **310** that can encompass a specialized network server, usually a specialized, network-based hardware device designed to perform a single or specialized set of server functions. It is usually characterized by a minimal operating architecture, and client access that is independent of any operating system or proprietary protocol. Print servers, terminal servers, audio servers, control remote access servers and network time servers are examples of server devices which are specialized for particular functions. The server **310** couples to the home network backbone **200** through a network interface **312**. Operably coupled to the network interface **312** are one or more processors, memory, and storage **314** to perform all of the typical function associated with the server **310**. In addition, the server **310** may comprise addition storage **316** such as a hard disk, a flash drive, or other type of storage device that is suitable for storage and playback of digital audio files or other functionality. A network interface **318** or similar circuitry is operably coupled to the processor **314** and provides server **310** with a connection to Internet interface **400**. The system **20** may also have any number of network control servers **310** on network backbone **200**. Often these types of specialized servers have unique configuration attributes in hardware or software that help them to perform best in their particular arena. While specialized hardware devices are often used to perform these functions in large systems, the specialized functions served by the network server could be performed by a more general use computer. And, control commands that affect the audio distribution can come from the network control server **310**.

FIG. 3 illustrates a network speaker embodiment **100A**. A network interface **110** couples the network backbone **200** of the system **20** (FIG. 1) to a network controller **120** which feeds a digital to analog converter (DAC) **122** via an audio format converter **121**. Receiving an output from the DAC **122** is a pre-amplifier **123** which also receives inputs from speaker sensors **124**. An amplifier **125** receives the output of the pre-amp **123** and feeds a speaker/microphone driver **126** coupled to speaker/microphone components **127**.

The network speakers **100A** may be enclosed in a case or box, in a ceiling embedded in or behind a wall, or in a car and constitute the most prevalent enabling components in the system **20**. Each network speaker **100A** communicates to the network backbone (Ethernet) **200** through the network interface **110** that handles the physical layer hardware protocol. The network interface **110** may connect to one or more physical layers, wired or unwired or both. From there the Network Speaker Controller **120** provides the intelligence to run the various application features of the network speaker, including the higher levels of the TCP/IP protocol. Audio sources (Digital Music content) received from the network and addressed to a particular network speaker **100A** are sent to the audio format converter **121** that converts the source digital audio format into a form ready to be converted to analog. The correctly re-formatted digital signal is sent to the digital to DAC **122** to be converted from digital to analog. The analog signal then goes to a pre-amp **123** where the signal is adjusted and filtered. Included in the pre-amp **123** can be an active crossover which operates at preamp level to limit the frequencies to the amplifier or amplifiers connected to it. The speaker components connected to these pre-amplifiers would therefore receive a limited frequency range, and can be optimized for the frequencies received. The pre-amp signal then goes to the amplifier section **125**, and the amplified signal proceeds to the speaker/microphone driver **126** and out the speaker/microphone components **127** to become audio sound waves. Because the application software in the Network Speaker controller **120** and audio format converter **121** can be updated over the network and with the use of sufficient processing power, and presence of ample memory, the network speaker **100A** can be made to play currently unknown digital formats in the future. The audio format converter **121** may have the DAC **122** built in. The speaker sensors **124** which may include temperature, SPL (such as a baffle microphone), ambient and noise floor, pressure, and voltage sensors provide the on board application speaker feedback which enables internal auto adjustment to enhance speaker protection and performance and allow for sending control signals back to other devices which may need/want the status information. A very useful application for this would be for the use of differential masking. This is a process in which you are comparing samples from the digital source against the real time encoding samples from within the air space. The original digital source is then subtracted from the combined real time encoding and the result is a new sample.

The network interface **110** connects the network speaker **100A** to the actual network backbone **200** and will vary depending on the physical media and physical layer protocol used. Network interface cards, commonly referred to as NICs, are often used to connect PCs to a wired network, and are used in the preferred embodiment when the network backbone is some form of wired cable or fiber optics. The NIC provides a physical connection between the networking cable and the computer's internal bus. Different computers have different bus architectures; the most common are PCO found on 486/Pentium PCs and ISA expansion slots commonly found on 386 and older PCs. NICs come in three basic varieties: 8-bit, 16-bit, and 32-bit. The larger the number of bits that can be transferred to the NIC, the faster the NIC can transfer data to the network cable. Many NIC adapters comply with Plug-n-Play specifications. On these systems, NICs are automatically configured without user intervention, while on non-Plug-n-Play systems, configuration is done manually through a setup program and/or DIP switches. Cards are available to support almost all network-

ing standards, including the latest Fast Ethernet environment. Fast Ethernet NICs are often 10/100 capable, and will automatically set to the appropriate speed. Full duplex networking is another option, where a dedicated connection to a switch allows a NIC to operate at twice the speed. NIC cards with multiple terminations capable of supporting multiple physical layer protocols or within protocol types are to be preferred. Within the NIC cards are transceivers used to connect nodes to the various Ethernet media. Most computers and network interface cards contain a built-in 10 BASE-T or 10 BASE2 transceiver, allowing them to be connected directly to Ethernet without requiring an external transceiver. Many Ethernet devices provide an AUI connector to allow the user to connect to any media type via an external transceiver. The AUI connector consists of a 15-pin D-shell type connector, female on the computer side, male on the transceiver side. Thickwire (10 BASE5) cables also use transceivers to allow connections. For Fast Ethernet networks, a new interface called the MII (Media Independent Interface) was developed to offer a flexible way to support 100 Mbps connections. The MII is a popular way to connect 100 BASE-FX links to copper-based Fast Ethernet devices. Wireless backbone physical layer network connections are made using RF network receivers made by companies such as Linksys, Cisco, IBM, DLINK and others, using wireless protocols such as 802.11X, UWB (ultra wideband), Bluetooth, and more as the network interface **101**.

The network speaker controller **120** is an embedded controller with flash memory programmed to function as a web server. The network speaker controller **120** and the audio format converter **121** are enabled to allow their application programming to be updated over the network, the network speaker can be made to play currently unknown digital formats in the future. The audio sources received from the network most likely will be in an encoded and/or compressed format. Digital audio coding or digital audio compression is the art of minimizing storage space (or channel bandwidth) requirements for audio data. Modern perceptual audio coding protocols, synonymously called digital audio compression techniques, like MPEG Layer-III or MPEG-2 AAC, ATRACK3, WMA, Ogg-Vorbis, or "Corona", and even a packet switched Dolby Digital (AC3 over Ipv6), exploit the properties of the human ear (the perception of sound) to achieve a respectable size reduction with little or no perceptible loss of quality. This compression is usually more than just reducing the sampling rate and the resolution of your samples. Basically, this is realized by perceptual coding techniques addressing the perception of sound waves by the human ear, which remove the redundant and irrelevant parts of the sound signal. The sensitivity of the human auditory systems for audio signals varies in the frequency domain being high for frequencies between 2.5 and 5 kHz and decreasing beyond and below that frequency band. The sensitivity is represented by the Threshold In Quiet so that any tone below the threshold will not be perceived. The most important psychoacoustics fact is the masking effect of spectral sound elements in an audio signal like tones and noise. For every tone in the audio signal a masking threshold can be calculated. If another tone lies below this masking threshold, it will be masked by the louder tone and remains inaudible, too. These inaudible elements of an audio signal are irrelevant for the human perception and thus can be eliminated by the encoder. The result after encoding and decoding is different from the original, but it will sound more or less the same to the human

ear. How closely it would sound to the original depends on how much compression had been performed on it.

Audio compression really consists of two parts. The first part, called encoding, transforms the digital audio data that resides, say, in a WAVE file, into a highly compressed form called bitstream (or coded audio data). To play the bitstream on your soundcard, you need the second part, called decoding. Decoding takes the bitstream and reconstructs it to a WAVE file. Highest coding efficiency is achieved with algorithms exploiting signal redundancies and irrelevancies in the frequency domain based on a model of the human auditory system. Current coders use the same basic structure. The coding scheme can be described as “perceptual noise shaping” or “perceptual sub-band/transform coding”. The encoder analyzes the spectral components of the audio signal by calculating a filterbank (transform) and applies a psychoacoustics model to estimate the just noticeable noise-level. In its quantization and coding stage, the encoder tries to allocate the available number of data bits in a way to meet both the bit rate and masking requirements. The decoder is much less complex. Its only task is to synthesize an audio signal out of the coded spectral components.

The term psychoacoustics describes the characteristics of the human auditory system on which modern audio coding technology is based providing audio quality of a coded and decoded audio signal the quality of the psychoacoustics model used by an audio encoder is of prime importance. Audio data decompression and de-coding of audio formats into the audio format acceptable the loudspeaker is performed by the audio format converter **121**. This audio format conversion of different formats allows high quality low bit-rate applications, like soundtracks for CD-ROM game, solid-state sound memories, Internet audio, or digital audio broadcasting systems to all be played over the same speaker. The audio format converter **121** function in the current embodiment of the networked speaker will be performed by an audio coding and decoding chip set (CODEC). CODEC hardware and or software is currently available from such companies as Micronas, Sigmatel, TI, Cirrus, Motorola, Fraunhofer, and Microsoft. CODECs handle the many current encoding protocols such as WMA, MPEG-2 AAC, MP3 (MPEG Layer III), MP3Pro, G2, ATRACK3, MP3 PRO, “Corona”, (WMAPro) Ogg-Vorbis and others. To best perform the audio format conversion function, the CODEC should be designed to handle all types of audio content, from speech-only audio recorded with a low sampling rate to high-quality stereo music. The CODEC should be very resistant to degradation due to packet loss, and have an efficient encoding algorithms to perform fast encodes and decodes, and to minimize the size of the compressed audio files, and still produce quality sound when they are decoded. In addition, the CODEC should be highly scalable and provide high-quality mono or stereo audio content over a wide range of bandwidths, to allow selection of the best combination of bandwidth and sampling rate for the particular content being played or recorded. Content encoded at 192 Kbps by the CODEC should be virtually indistinguishable to a human ear from content originating on a compact disc. This extremely high-quality content is called CD transparency. A preferred embodiment of this invention uses the Windows Media Audio (WMA) Audio CODEC by Microsoft. The audio format converter **121** function could also be performed by a decoder chip with no encoder functionality if no digital audio reformatting or digital encoding of analog audio is desired.

The digital to analog converter **122**, converts a digital input into an analog level output. At the pre-amp **123**, the

analog signal is adjusted and filtered, and any desired active or electronic crossover may be performed. An electric crossover is a powered electronic circuit which limits or divides frequencies. Most electronic crossovers have output controls for each individual channel. This allows you to set the gains for all amplifiers at one convenient location, as well as the ability to level match a system. Some crossovers will allow you to set the low and high pass filters separately, which allows you to tune out acoustic peaks or valleys at or near the crossover frequencies. One of the advantages of electronic crossovers is that there is little or no insertion loss. Passive crossovers reduce the amplifier power slightly, due to their resistance. Another advantage of electronic crossovers is the ability to separate low frequencies into their own exclusive amplifier, which reduces distortion heard at high volumes in the high frequency speakers. Amplification of low frequencies requires greater power than higher frequencies. When an amplifier is at or near peak output, clipping may occur, which is able to destroy tweeters and other speakers with small voice coils. A separate low frequency amplifier allows the total system to play louder and with lower distortion. An adjustable crossover allows the user to make crossover changes easily and to immediately hear the effect of the changes. Changing the filters, or crossover points, lets users adjust the audio to meet their preferences. The electronic crossover, by limiting the frequencies to the amplifier or amplifiers connected to it, also ensures that the speakers which are connected to these amplifier(s) would therefore receive a limited frequency range, and these speakers can be optimized for the frequencies received. It also enables personal preferences in frequency range pre-amplification adjustment. The advantages of using active filters are that they are built onto the pre-amp circuit board. Changing the filters (or crossover points) is usually accomplished through external dial turning, by changing frequency modules with a switch or by changing crossovers if fixed types are used. An adjustable crossover is preferred.

The amplifier **125** is comprised of one or more amplifier circuits that amplify the audio signal to the desired final signal strength. Using multiple amplifiers takes advantage of the crossover frequency filtering to optimize the amplifier for the frequency range received. Amplifiers using the latest in digital amplifier technology that can efficiently produce large amounts of power with a much smaller heat sink than in past designs are preferable, and this also will eliminate the need for another DAC. The speaker/microphone driver **126** is comprised of one or more speaker drivers circuits. Using multiple drivers for multiple speakers allows the speakers to be optimized for the frequency range received. The speaker/microphone components **127** convert the signal to sound and are voiced and designed to handle a wide dynamic range of audio frequencies and are able to aid in the accurate reproduction of sound from a digital source.

FIG. 4A shows another network speaker embodiment **100B**. The speaker embodiment **100B** includes all of the components of the speaker embodiment **100A** and identical components bear the same reference numerals. In addition, speaker embodiment includes an analog to digital converter (ADC) **128** and a modified speaker/microphone driver **126b**. The speaker/microphone driver **126b** circuitry is expanded to serve as both an output driver and a microphone input for half duplex operation (one way conversations), and an internal microphone can implement a full duplex operation (simultaneous two way conversations). The microphone input is sent to the pre-amp **123** for signal adjustment and filtering. From there it is sent to the analog to digital converter **128** to convert the analog signal to a simple digital

13

format. The audio format converter **121** then takes the digital microphone input and compresses and encodes it into a desired format for distribution. The encoded format of which may vary, depending on the application is sent to the network controller **120** where, depending on the software application and programming, its final destination and function are determined. The input may be stored locally for future audio feedback, used locally, or it may be sent out to the network through the network interface **110**. The input could be used with a voice recognition application to initiate spoken audio or home control commands. Speaker sensors **124** feedback received by the pre-amp **123** can also be sent to the ADC **128** to be converted from analog to digital format, and then passed on to the network controller **120**. Depending on the network controller **120** applications, the feedback can then be sent out to network interface **110** onto the network backbone **200** as an alarm or other condition if desired. Additional features in the audio format converter **121** in conjunction with application software could enable the ability to change audio setting(s) based on the type of music that is being played, or even the user playing it, or Time of Day (TOD). The network speaker **100B** may have the ability, through the audio format converter **121** or other circuitry, to support headphones.

FIG. **4B** shows another embodiment of the disclosed invention that shows a network amplifier **101** that provides system **20** with the ability to convert, adjust, filter, and amplify digital analog and/or video signals to and from analog audio and/or video signals from and to any analog device. One skilled in the art will appreciate that a network speaker such as described in this disclosure is electronically equivalent to a network amplifier in that they both convert and amplify digital and analog signals in the same fashion as described elsewhere in this disclosure. Network Amplifier **101** couples to through a network interface **110** that couples the Network Amplifier **101** to the network backbone **200**. The network interface **110** is coupled to network controller **120**. The network controller **120** couples to DSP **160**. The network controller **120** controls the processing of the digital signal to and from the network backbone **200**. In addition, the network controller **120** includes an embedded controller with a processor, memory, and storage and which is programmed to function as a web server.

As discussed elsewhere in this present disclosure, DSP **160** may include one or more of the following functionalities that are described in some of the network speaker embodiments and include circuitry such as an Audio Format Converter **121**, an ADC **128**, a DAC **122**, a Pre-Amp **123**, and an Amplifier **125**. DSP **160** converts and amplifies the digital analog and/or video signals to and from analog audio and/or video signals. DSP **160** may include a pre-amplifier that adjusts and filters the analog signal and an amplifier that amplifies the analog audio signal. In addition, DSP **160** may include an electronic crossover for frequency division.

Analog sensors **124** are coupled to DSP **160** and may include temperature, SPL (such as a baffle microphone), ambient and noise floor, pressure, and voltage sensors that provide the on board application with feedback which enables internal auto adjustment to enhance the amplifier protection and performance and allow for sending control signals back to other devices which may need/want the status information. One such internal auto adjustment may include frequency separation from an analog signal gathered from a microphone. And one example of feedback would be an alarm condition or other type of status condition. One skilled in the art will appreciate that Analog sensors **124** may be included as part of a DSP.

14

Analog driver **126** is coupled to DSP **160** is comprised of circuits that couple network amplifier **101** to various analog components **127** that include microphones and speakers. One skilled in the art will appreciate the DSP **160** may incorporate the necessary analog driver circuitry so as to directly couple to analog components **127**.

FIG. **5** depicts another network speaker embodiment **100C** with wireless remote control access. All components of speaker embodiment **100B** are present in speaker embodiment **100C** and bear the same reference numerals. In addition, additional components provide wireless remote control from IR and RF remotes. It should be noted that the additional components could have been added to the network speaker embodiment **100A** as well. An internal IR sensor **131** senses IR from one or more external IR remotes **170**. The sensed IR is sent to an IR receiver **130** that processed the IR input, and the processed IR input is sent to the network controller **120** which then performs commands as per its application software. If desired, the IR sensor **131** may be external of the speaker **100C** which then can be installed behind a wall as wall speakers, and still receive IR. The network controller **120** can send the processed IR commands out the network interface **110** onto the network to be processed remotely by the Legacy Converter/Controller **600** which then translates them into commands to the legacy sources **500**. Alternatively, the network controller **120** can send the processed IR commands out the network interface **110** onto the network to be processed remotely by the legacy Converter/Controller **60** which then translates them into Legacy home control network **700** commands. In the same manner, RF control access is provided by a RF Sensor/Transceiver **135** which receives input from RF remotes **175** and other network speaker transceivers, and transmits information to the network controller **120**. While this embodiment **100C** shows both IR and RF access through the same network speaker, it will be appreciated that IR only control access or RF only control access could be implemented.

The wireless control access allow IR or RF input to the speakers **100C** to be used to remotely control the system **20** including control of the audio, (including multi destination sync), video, HVAC, security, room light level house scenes, etc., if the system is so programmed. Where the software application includes the ability to "learn" new IR commands and associate them with audio or house control commands, existing legacy sources with IR remotes can be integrated into the network controller through the legacy Converter/Controller **600**. And because the legacy Converter/Controller **600** is upgradeable over the network, the network speaker IR input ability could be made to control currently unknown system devices in the future.

FIG. **6** shows another network speaker embodiment **100D** that serves as bridge between one or more wireless network devices and a wired segment of the network **200**, known as a wireless access point. This wireless access point embodiment includes the components of embodiment **100B** with additional components added for wireless-wired bridging, such as dual mode ad-hoc to infrastructure mode. The network **200** consists of at least one physically wired network section **240** and at least wireless network segment **250**. The network interface **110** consists of two parts, a wired network interface **111** connecting the network speaker **100D** to the wired network backbone **240** and an RF network interface **112** connecting the network speaker **100D** to the wireless RF network backbone **250**. Network communication can pass between the wired backbone **240** and the wireless RF network backbone **250** via the network speaker

15

100D. The RF network interface 112 consists of an RF receiver/transmitter capable of both receiving and sending RF network communication.

FIG. 7 illustrates another speaker embodiment 100E that has wireless control access and that serves as a wireless access point. This wireless access point embodiment includes all of the components of embodiments of 100B, 100C and 100D.

If a home has a network speaker type system, the application software opens all kinds of possibilities. New sources or new source content may enable these intelligent speakers 100 to have more features and playback formats that are not in existence today, and to adjust to the source content. An example of this would be the ability to change audio settings based on the type of music that is being played, or even the user playing it, or Time of Day (TOC). This will be highly customizable long past the time of installation, to keep the audio system upgradeable without structural changes to the home even if the network speakers are embedded in walls and other not easily accessed locations. In addition, a network speaker 100 with a microphone and the appropriate application software could record and route messages digitally to any house network node or internet node; locate and identify a user in a room, which in turn enables the system 20 to route voice mail and message to the room the user is presently in on demand; locate and identify a room user, which in turn enables the system to route voice mail and message to the room the user is presently in on demand; serve as a voice recognition and authorization point to enable direct voice control of any node on the network or any legacy audio source 500 or legacy control network 700 device that may be connected to the network 200 through a legacy converter/controller 600; or to automatically record and/or route voice messages from one user to the room in which the recipient identified in the voice message is currently located. Multiple network speakers 100 with microphones in one room could even triangulate the location of the user, which in turn enables the system to optimize the audio for the users current location.

The network speaker 100 with a sufficient memory and the appropriate application software could store voice mail to be played on demand by the room user or in a totally wireless network 200 serve as a wireless repeater within a home if the wireless communication medium signal strength was insufficient to reach all rooms or areas of the home from all locations. Also, a strategically placed network speaker 100 serving as a wireless access point allows the communication of audio, data, commands or any other communications from mobile network nodes whenever they are within communication range, such as PDAs, mobile controllers, mobile computers, wireless headphones, or network speakers 100 in mobile units such as automobiles.

A network speaker 100 with IR or RF receivers and the appropriate application software would allow wireless remote control, status and feedback from any IR or RF remote, or other network speaker transceiver, to any node on the network or any legacy audio source 500 or legacy control network 700 device that may be connected to the network 200 through a legacy converter/controller 600. A network speaker 100 with a RF receiver capable of transmitting RF could enable wireless non-networked headphones. Also, a network speaker 100 could encode and send and transmit sound and images from a room out on the network, as well as act as the source point for room control and automation and voice recognition services for control and automation. In addition, a network speaker 100 could participate in a multi speaker session during which each network speaker

16

100 could perform as a master or slave mode. A network speaker 100 in the master mode would control and distribute multi session clocks and this is where they would originate and be calculated. The network speaker 100 in the slave mode would receive via TCP/IP and/or RF clocking information from the master in a multi session mode.

A network speaker 100 additionally could be an audio source locally within the room via internal solid-state memory as well as terrestrial analog reception (AM/FM/CATV) if components were added to receive and play back digital and analog terrestrial radio frequencies (AM/FM/CATV).

FIG. 8 is a block diagram that shows a baffle microphone 124 and a tuner 162 coupled to a DSP (digital signal processor) 160. This figure illustrates that DSP 160 (also described as a signal processor means elsewhere in the original disclosure) is an alternative embodiment to the use of one or more of the following components that include a separate Audio Format Converter 121, an ADC 128, a DAC 122, a Pre-Amp 123, and an Amplifier 125 as illustrated in various figures of the present disclosure. The DSP 160 may include a real time adaptive analyzer to process information. DSP 160 may also include a speaker controller for providing intelligence to operate application protocol.

FIG. 9 depicts a legacy Audio Converter/Controller 600 embodiment, which includes many similar components as the Network Speaker 100. The legacy Audio Converter/Controller 600 communicates with the network backbone (Ethernet) 200 through a network interface 610 which handles the physical layer hardware protocol and may connect to one or more physical layers, wired or unwired or both. Coupled to the network interface 610 is a Network Controller 620 which provides the intelligence to run various application features of the legacy Audio Converter/Controller 600, including the higher levels of the TCP/IP protocol. The Network Controller 620 controls an audio format converter 621 which converts the legacy source audio into the desired network digital format for distribution. Digital audio from legacy sources 500 are transmitted directly to the audio format converter 621 to be re-formatted into the desired digital format. Analog audio from legacy sources 500 are fed to an analog to digital converter ("ADC") 622, and the resultant digitized signal then goes to the audio format converter 621 to be coded into the desired digital format. The Network Controller 620 takes the properly formatted digital audio and sends it to the network 200 via the network interface 610. Also, the audio format converter 621 may consist of multiple encoders to provide multiple conversions of different legacy audio inputs simultaneously. The Legacy Converter/Controller 600 uses the analog video from the legacy source device for encoding to a packet switched digital format such as WMAPro "Corona", and also uses the analog video inputs for power status and feedback.

The network interface 610 may vary depending on the physical medium and physical layer protocol used. Network interface cards, commonly referred to as NICs, are often used to connect a PC to a wired network, and are used in the preferred embodiment when the network backbone is some form of wired cable or fiber optics. Such a NIC provides a physical connection between the networking cable and the computer's internal bus. Different computers have different bus architectures; the most common are PCI found on 486/Pentium PCs and ISA expansion slots commonly found on 386 and older PCs. Typically NICs come in three basic varieties: 8-bit, 16-bit, and 32-bit. The larger the number of bits that can be transferred to the NIC, the faster the NIC can

transfer data to the network cable. Many NIC adapters comply with Plug-n-Play specifications. On these systems, NICs are automatically configured without user intervention, while on non-Plug-n-Play systems, configuration is done manually through a setup program and/or DIP switches. Cards are available to support almost all networking standards, including the latest Fast Ethernet environment. Fast Ethernet NICs are often 10/100 capable, and will automatically set to the appropriate speed. Full duplex networking is another option, where a dedicated connection to a switch allows a NIC to operate at twice the speed. NIC cards with multiple terminations capable of supporting multiple physical layer protocols or within protocol types are preferred so that the NIC cards include transceivers used to connect nodes to the various Ethernet media. Most computers and network interface cards contain a built-in 10 BASE-T or 10 BASE2 transceiver, allowing them to be connected directly to Ethernet without requiring an external transceiver. Many Ethernet devices provide an AUI connector to allow the user to connect to any media type via an external transceiver. The AUI connector consists of a 15-pin D-shell type connector, female on the computer side, male on the transceiver side. Thickwire (10 BASE5) cables also use transceivers to allow connections. For Fast Ethernet networks, a new interface called the MII (Media Independent Interface) was developed to offer a flexible way to support 100 Mbps connections. The MII is a popular way to connect 100 BASE-FX links to copper-based Fast Ethernet devices. Wireless backbone physical layer network connections are made using RF network receivers made by companies such as Linksys, Cisco, IBM, DLINK, and others, using wireless protocols such as 802.11X, UWB, Bluetooth, and more as the network interface **610**.

The network speaker controller **620** is an embedded controller with flash memory programmed to function as a web server and enabled with the audio format converter **621** to allow their application programming to be updated over the network, the legacy Audio Converter/Controller **600** can be made to code audio to currently unknown digital formats in the future. As in the speaker embodiments described above, the desired audio to be distributed will likely be in a coded and/or compressed format. Digital audio coding or digital audio compression is the art of minimizing storage space (or channel bandwidth) requirements for audio data. Modern perceptual audio coding protocols, synonymously called digital audio compression techniques, like MPEG Layer-III or MPEG-2 AAC, ATRACK3, G2, WMA, Ogg-Vorbis, or WMAPro, "Corona", exploit the properties of the human ear (the perception of sound) to achieve a respectable size reduction with little or no perceptible loss of quality. As described above, this compression, in addition to reducing the sampling rate and the resolution of the audio samples employees perceptual coding techniques addressing the perception of sound waves by the human ear, that remove the redundant and irrelevant parts of the sound signal. The sensitivity of the human auditory systems for audio signals varies in the frequency domain being high for frequencies between 2.5 and 5 kHz and decreasing beyond and below this frequency band. The sensitivity is represented by the Threshold In Quiet Any tone below this threshold will not be perceived. The most important psychoacoustics fact is the masking effect of spectral sound elements in an audio signal like tones and noise. For every tone in the audio signal a masking threshold can be calculated. If another tone lies below this masking threshold, it will be masked by the louder tone and remains inaudible too. These inaudible elements of an audio signal are irrelevant for the human

perception and thus can be eliminated by the coder. The sound resulting after coding and decoding is different, but will be perceived more or less the same by the human ear. How closely it would sound to the original depends on how much compression had been performed.

Audio compression actually consists of two parts. The first part, called coding or encoding, transforms the digital audio data that resides, say, in a WAVE file, into a highly compressed form called bitstream (or coded audio data). To play the bitstream on your soundcard, you need the second part, called decoding. Decoding takes the bitstream and reconstructs it to a WAVE file. Highest coding efficiency is achieved with algorithms exploiting signal redundancies and irrelevancies in the frequency domain based on a model of the human auditory system. Current coders use the same basic structure to produce coding that can be described as "perceptual noise shaping" or "perceptual sub-band/transform coding". The encoder analyzes the spectral components of the audio signal by calculating a filterbank (transform) and applies a psychoacoustics model to estimate the just noticeable noise-level. In its quantization and coding stage, the encoder tries to allocate the available number of data bits in a way to meet both the bit rate and masking requirements. The decoder is much less complex. Its only task is to synthesize an audio signal out of the coded spectral components. Psychoacoustics describes the characteristics of the human auditory system on which modern audio coding technology is based. For the audio quality of a coded and decoded audio signal the quality of the psychoacoustics model used by an audio encoder is of prime importance.

The audio format converter **621** performs audio data compression and encoding of audio formats into the audio format acceptable for distribution to the end receiver on the network and can consist of an audio encoder-decoder chip (CODEC). To best perform the audio format conversion function, the CODEC should be designed to handle all types of audio content, from speech-only audio recorded with a low sampling rate to high-quality stereo music. The CODEC should be very resistant to degradation due to packet loss, and have efficient encoding algorithms to perform fast encodes and decodes, and to minimize the size of the compressed audio files, and still produce quality sound when they are decoded. Also, the CODEC should be highly scalable and provide high-quality mono or stereo audio content over a wide range of bandwidths, to allow selection of the best combination of bandwidth and sampling rate for the particular content being played or recorded. Content encoded at 192 Kbps by the CODEC should be virtually indistinguishable to a human ear from content originating on a compact disc. This extremely high-quality content is called CD transparency.

The analog to digital converter **622**, commonly referred to as an ADC, converts an analog level input to a digital output. Adding a microphone speaker input to the ADC will enable voice control of the legacy Audio Converter/Controller **600**. It would also enable the legacy Audio Converter/Controller **600** to record audio input for later use as system messages or audio feedback. Depending on the software application and programming in the network controller **620**, the audio input may be stored locally for future audio feedback, used locally, or it may be fed out to the network through the network interface **610**. The audio input could be used with a voice recognition application to initiate spoken audio or home control commands.

The Legacy Audio Converter/Controller **600** may also communicate with the legacy sources **500** using a legacy communication method, such as IR or serial commands, that

are understood by the legacy device. The planned embodiment of the invention will use the fixed set of serial commands already understood by the target legacy source. The network controller **620** controls and communicates with a legacy controller **624**, which also communicates with the legacy source **500** through a legacy audio network interface **623**. In a preferred embodiment of the invention, a RS-232 serial command interface will be used. The functions of the network controller **620** and the legacy controller can be combined into one embedded controller.

The Legacy Audio converter/Controller **600** may also communicate with the legacy home control network **700** using the network communication method understood and practiced by the legacy home control network **700** and such communication may vary greatly depending on the legacy home control network **700** being used. A preferred embodiment of the invention will use the CEBus powerline protocol for its communication method. The legacy controller **624** controls and communicates via a legacy home control network interface **625**, with a legacy home control network **700**. The functions of the legacy controller in controlling the legacy sources **500** and the legacy home control network **700** and the legacy controller could be separated out into two separate embedded controllers, or combined with the network controller **620**. If no legacy source **500** is available, the legacy audio network interface **623** and the legacy source control function of the legacy controller **624** may be eliminated. Similarly, in the absence of a legacy home control network **700**, the legacy home control network interface **625** and the legacy home network control function of the legacy controller **624** may be eliminated.

As illustrated in FIG. **10** network speaker **100F** can receive DC current from external regulated power supplies over existing 14-18 AWG speaker wire or can employ PoE (Power over Ethernet) technology to trickle charge the battery. Also, charge status can be provided for the battery **800**.

Network speaker **100F** has power applied as DC current from a rechargeable battery source **800** either located within the speaker or inserted into the speaker as a removable battery pack. This would also allow for line power status, which would perform a function specific to the application once this condition occurs.

FIG. **11** depicts another speaker embodiment **100G** which also can be battery powered. In addition, the speaker **100G** includes an ESM (Energy Storage Module) which improves audio performance.

While the present disclosure has been described herein with respect to certain illustrated and described embodiments, those of ordinary skill in the art will recognize and appreciate that the present invention is not so limited. Rather, many additions, deletions, and modifications to the illustrated and described embodiments may be made without departing from the scope of the invention as hereinafter claimed along with their legal equivalents. In addition, features from one embodiment may be combined with features of another embodiment while still being encompassed within the scope of the invention as contemplated by the inventor. The disclosure of the present invention is exemplary only, with the true scope of the present invention being determined by the included claims.

The invention claimed is:

1. A legacy converter for an audio distribution system that uses a local area network where the legacy converter converts a digital audio signal to and from an analog audio signal and provides an external bridge connection between

the audio system and one or more legacy sources and one or more legacy control networks, comprising:

- a network controller that controls the processing of the digital audio signal to and from the audio distribution system on the local area network, said network controller further comprises an embedded controller with memory;
 - a network interface that couples said network controller to the audio distribution system on the local area network;
 - an audio format converter that couples to said network controller and converts and formats the digital audio signal, said audio format converter is updated through the local area network, said audio format converter includes one or more audio encoders to provide multiple conversions of different legacy audio inputs simultaneously;
 - an analog to digital converter that couples to said audio format converter and converts the analog audio signal from legacy sources to the digital audio signal;
 - a legacy controller that couples to said network controller and controls and communicates with legacy sources and or the legacy control network;
 - a legacy audio network interface that bridges the legacy sources to said legacy controller; and
 - a legacy control network interface that bridges the legacy control network to said legacy controller.
2. The claim according to claim **1** further comprising a distributed clock signal.
3. The claim according to claim **1** wherein said legacy audio network interface uses a legacy communication method to communicate with the legacy sources.
4. The claim according to claim **1** wherein said legacy audio network interface uses a network communication method to communicate with the legacy sources.
5. The claim according to claim **1** wherein said analog to digital converter further comprises a microphone connection to enable voice recognition and or voice control.
6. The claim according to claim **1** wherein said embedded controller is programmed to function as a web server.
7. The claim according to claim **1** wherein the legacy converter records and/or stores the digital audio input.
8. A method to make a legacy converter for an audio distribution system that uses a local area network where the legacy converter converts a digital audio signal to and from an analog audio signal and provides an external bridge connection between the audio system and one or more legacy sources and one or more legacy control networks, comprising:
- providing a network controller that controls the processing of the digital audio signal to and from the audio distribution system on the local area network, said network controller further comprises an embedded controller with memory;
 - coupling said network controller to the audio distribution system on the local area network with a network interface;
 - coupling an audio format converter to said network controller, said audio format converter converts and formats the digital audio signal, said audio format converter is updated through the local area network, said audio format converter includes one or more audio encoders to provide multiple conversions of different legacy audio inputs simultaneously;
 - coupling an analog to digital converter to said audio format converter, said analog to digital converter converts the analog audio signal from legacy sources to the digital audio signal;

21

coupling a legacy controller to said network controller, said legacy controller controls and communicates with legacy sources and or the legacy control network; bridging the legacy sources to said legacy controller with a legacy audio network interface; and bridging the legacy control network to said legacy controller with a legacy control network interface.

9. The claim according to claim 8 further comprising a distributed clock signal.

10. The claim according to claim 8 wherein said legacy audio network interface uses a legacy communication method to communicate with the legacy sources.

11. The claim according to claim 8 wherein said legacy audio network interface uses a network communication method to communicate with the legacy sources.

12. The claim according to claim 8 wherein said analog to digital converter further comprises a microphone connection to enable voice recognition and or voice control.

13. The claim according to claim 8 wherein said embedded controller is programmed to function as a web server.

14. The claim according to claim 8 wherein the legacy converter records and/or stores the digital audio input.

15. A method to use a legacy converter for an audio distribution system that uses a local area network where the legacy converter converts a digital audio signal to and from an analog audio signal and provides an external bridge connection between the audio system and one or more legacy sources and one or more legacy control networks, comprising:

controlling the processing of the digital audio signal to and from the audio distribution system on the local area network with a network controller, said network controller further comprises an embedded controller with memory, said network controller couples to the audio network distribution system on the local area network through a network interface;

converting and formatting the digital audio signal with an audio format converter that couples to said network controller, said audio format converter is updated through the local area network, said audio format converter includes one or more audio encoders to provide multiple conversions of different legacy audio inputs simultaneously;

converting the analog audio signal from legacy sources to the digital audio signal with an analog to digital converter that couples to said audio format converter; and controlling and communicating the legacy sources and or the legacy control network with a legacy controller that couples to said network controller, said legacy controller bridges the legacy sources through a legacy audio network interface, said legacy controller bridges the legacy control network through a legacy home control network interface.

16. The claim according to claim 15 further comprising a distributed clock signal.

17. The claim according to claim 15 wherein said legacy audio network interface uses a legacy communication method to communicate with the legacy sources.

22

18. The claim according to claim 15 wherein said legacy audio network interface uses a network communication method to communicate with the legacy sources.

19. The claim according to claim 15 wherein said analog to digital converter further comprises a microphone connection to enable voice recognition and or voice control.

20. The claim according to claim 15 wherein said embedded controller is programmed to function as a web server.

21. The claim according to claim 15 wherein the legacy converter records and/or stores the digital audio input.

22. A non-transitory program storage device readable by a computing device that tangibly embodies a program of instructions executable by the computing device to perform a method to use a legacy converter for an audio distribution system that uses a local area network where the legacy converter converts a digital audio signal to and from an analog audio signal and provides an external bridge connection between the audio system and one or more legacy sources and one or more legacy control networks, comprising:

controlling the processing of the digital audio signal to and from the audio distribution system on the local area network with a network controller, said network controller further comprises an embedded controller with memory, said network controller couples to the audio network distribution system on the local area network through a network interface;

converting and formatting the digital audio signal with an audio format converter that couples to said network controller, said audio format converter is updated through the local area network, said audio format converter includes one or more audio encoders to provide multiple conversions of different legacy audio inputs simultaneously;

converting the analog audio signal from legacy sources to the digital audio signal with an analog to digital converter that couples to said audio format converter; and controlling and communicating the legacy sources and or the legacy control network with a legacy controller that couples to said network controller, said legacy controller bridges the legacy sources through a legacy audio network interface, said legacy controller bridges the legacy control network through a legacy home control network interface.

23. The claim according to claim 22 further comprising a distributed clock signal.

24. The claim according to claim 22 wherein said legacy audio network interface uses a legacy communication method to communicate with the legacy sources.

25. The claim according to claim 22 wherein said legacy audio network interface uses a network communication method to communicate with the legacy sources.

26. The claim according to claim 22 wherein said analog to digital converter further comprises a microphone connection to enable voice recognition and or voice control.

27. The claim according to claim 22 wherein said embedded controller is programmed to function as a web server.

28. The claim according to claim 22 wherein the legacy converter records and/or stores the digital audio input.

* * * * *