

The University of New Hampshire Law Review

Volume 8
Number 1 *Pierce Law Review*

Article 6

December 2009

Egyptian Goddess, Inc. v. Swisa, Inc.: A Dramatic Change in the Law of Design Patents?

Evan Szarenski
Franklin Pierce Law Center, Concord, NH

Follow this and additional works at: https://scholars.unh.edu/unh_lr



Part of the [Intellectual Property Law Commons](#), and the [Technology and Innovation Commons](#)

Repository Citation

Evan Szarenski, *Egyptian Goddess, Inc. v. Swisa, Inc.: A Dramatic Change in the Law of Design Patents?*, 8 *Pierce L. Rev.* 89 (2009), available at http://scholars.unh.edu/unh_lr/vol8/iss1/6

This Notes is brought to you for free and open access by the University of New Hampshire – Franklin Pierce School of Law at University of New Hampshire Scholars' Repository. It has been accepted for inclusion in The University of New Hampshire Law Review by an authorized editor of University of New Hampshire Scholars' Repository. For more information, please contact sue.zago@law.unh.edu.

Egyptian Goddess, Inc. v. Swisa, Inc.: A Dramatic Change in the Law of Design Patents?

EVAN SZARENSKI*

TABLE OF CONTENTS

I.	INTRODUCTION	89
II.	BACKGROUND	90
III.	ORIGIN OF THE ORDINARY OBSERVER	92
IV.	THE PATH TO POINT OF NOVELTY	95
V.	<i>LITTON SYSTEMS</i> AND ITS AFTERMATH	100
VI.	<i>EGYPTIAN GODDESS V. SWISA</i>	102
	A. <i>District Court</i>	102
	B. <i>Panel Hearing</i>	104
	C. <i>En Banc</i>	105
VII.	THE EFFECT OF THE ABOLITION OF THE POINT-OF-NOVELTY TEST	108
	A. <i>Post-Egyptian Goddess</i>	109
	B. <i>Pre-Egyptian Goddess</i>	113
VIII.	CONCLUSION	116

I. INTRODUCTION

On September 22, 2008, the Federal Circuit, sitting en banc, handed down the most important decision in design patent law in nearly twenty-five years.¹ *Egyptian Goddess, Inc. v. Swisa, Inc.*

* J.D. Candidate, Franklin Pierce Law Center (2010); B.S.E., Electrical Engineering, University of Michigan, magna cum laude (2006). This note was the winning entry in the third annual Pierce Law Student Symposium writing competition. The author would like to thank Pierce Law Review members Elizabeth Lahey, Wallace Young, and Paul Smith for their feedback.

1. See Perry J. Saidman, *Egyptian Goddess Exposed!*, 90 J. PAT. & TRADEMARK OFF. SOC'Y 859, 885 (2008) [hereinafter *Exposed!*] (“*Egyptian Goddess* represents a sea change in the law”); Rebecca L. Hanovice, ‘*Egyptian Goddess*’ *Revises Design Patent Analysis: Federal Circuit Disposed of the Long-Standing ‘Point of*

(*Egyptian Goddess III*)² abolished the point-of-novelty test first set out in *Sears, Roebuck & Co. v. Talge*³ and adopted by the Federal Circuit in *Litton Systems, Inc. v. Whirlpool Corp.*⁴ The point-of-novelty test required patent holders to prove that an accused design appropriated the element which sets the patented design apart from the prior art—in addition to the ordinary-observer standard’s requirement of having substantially the same appearance—in order to prove infringement.⁵

The point-of-novelty test proved difficult to apply and often rendered valid design patents unenforceable.⁶ Additionally, the test had no basis in Supreme Court precedent.⁷ In place of the rigid point-of-novelty test, the Federal Circuit announced a more malleable ordinary-observer standard that gives factfinders more leeway in evaluating infringement.⁸ *Egyptian Goddess* has been hailed as a major victory for owners of design patents, but this Note argues that the actual effect will be much more muted.

After giving an overview of design patents, this Note will analyze the cases that preceded the Federal Circuit’s adoption of the point-of-novelty test in *Litton Systems*. Additionally, this Note will discuss some of the cases decided during the reign of the point-of-novelty test to demonstrate the problems inherent in it. After covering *Egyptian Goddess* in depth, the Note will then argue that *Egyptian Goddess*’s effect will be limited.

II. BACKGROUND

The U.S. Constitution grants Congress the power “[t]o promote the Progress of Science and useful Arts, by securing for limited Times to Authors and Inventors the exclusive Right to their respec-

Novelty’ Test, NAT’L L.J. (N.Y., N.Y.), Dec. 1, 2008, at S3 (“This is a wake-up call . . .”).

2. 543 F.3d 665 (Fed. Cir. 2008).

3. 140 F.2d 395 (8th Cir. 1944).

4. 728 F.2d 1423 (Fed. Cir. 1984).

5. *See id.* at 1444.

6. *See infra* notes 109–13 and accompanying text.

7. *See Egyptian Goddess III*, 543 F.3d at 672.

8. *See id.* at 678.

tive Writings and Discoveries.”⁹ Congress first explicitly provided patent protection for designs in 1842.¹⁰ Currently, design patents are available for “any new, original and ornamental design for an article of manufacture.”¹¹ In general, design patents are governed by the same statutory provisions as utility patents.¹² Notably, design patents have terms of fourteen years from the date of granting,¹³ and, in an infringement action, patentees have available an additional remedy vis-a-vis utility patents.¹⁴

Design patents cover only the ornamental features of a design. Generally, these ornamental features consist of one or both of (1) “a design for an ornament, impression, print, or picture applied to or embodied in an article of manufacture” or (2) “a design for the shape or configuration of an article of manufacture.”¹⁵ Unlike utility patents, design patents are generally not accompanied by verbal claims.¹⁶ Rather, each design patent can only contain a single claim, represented by drawings.¹⁷

9. U.S. CONST. art. I, § 8, cl. 8.

10. *See* Act of Aug. 29, 1842, ch. 263, 5 Stat. 543 (“[A]ny citizen or citizens . . . who by his, her, or their own industry, genius, efforts, and expense, may have invented or produced any new and original design for a manufacture . . . may make application in writing to the Commissioner of Patents . . . and the Commissioner . . . may grant a patent therefor . . .”). Under this act, design patents were given terms of seven years. *Id.* § 3, 5 Stat. at 544.

11. 35 U.S.C. § 171 (2006).

12. *Id.*

13. *Id.* § 173. In general, a utility patent’s term is twenty years from the date of application. *Id.* § 154.

14. *See id.* § 289. Specifically, the owner of a design patent is entitled to an infringer’s total profits, not less than \$250. *Id.* This is in addition to damages sufficient “to return the patent owner to the financial position he would have occupied but for the infringement” that is available to all patentees. *Carborundum Co. v. Molten Metal Equip. Innovations, Inc.*, 72 F.3d 872, 881 (Fed. Cir. 1995) (citing *Rite-Hite Corp. v. Kelley Co.*, 56 F.3d 1538, 1545 (Fed. Cir. 1995)); *see* 35 U.S.C. § 289. Section 289 prohibits a patentee from “twice recover[ing] the profit made from the infringement.” 35 U.S.C. § 289.

15. U.S. PATENT & TRADEMARK OFFICE, U.S. DEP’T OF COMMERCE, MANUAL OF PATENT EXAMINING PROCEDURE § 1504.01 (8th ed., rev. 7 2008).

16. *Id.* § 1503.01.

17. *Id.*

Design patents may overlap with other types of intellectual property. In *In re Yardley*,¹⁸ the Court of Customs and Patent Appeals allowed for the design of a watch to be both copyrighted and protected by design patent, stating:

Congress, through its legislation under the authority of the Constitution, has interpreted the Constitution as authorizing an area of overlap where a certain type of creation may be the subject matter of a copyright and the subject matter of a design patent. We see nothing in that legislation which is contradictory and repugnant to the intent of the framers of the Constitution.¹⁹

Similarly, the same design may be protected under both trademark and design patent. The Court of Customs and Patent Appeals held in *In re Mogen David Wine Corp.*²⁰ that trademark rights “exist independently of [design patent rights], under different law and for different reasons.”²¹ Therefore, the applicant was allowed to receive protection under both statutes.²²

III. ORIGIN OF THE ORDINARY OBSERVER

The first U.S. Supreme Court case to attempt to set a standard for design-patent infringement was *Gorham Co. v. White*.²³ The plaintiff in *Gorham* held a patent on a design for the handles of tablespoons and forks.²⁴ The patented design was very popular, and the value of the patent was “immense.”²⁵ White, the defendant, obtained

18. 493 F.2d 1389 (C.C.P.A. 1974).

19. *Id.* at 1395–96.

20. 328 F.2d 925 (C.C.P.A. 1964).

21. *Id.* at 930.

22. *Id.* at 932. This dual-coverage was a basis in the U.S. Supreme Court’s recent requirement of secondary meaning for trademark protection of product configurations. *See Wal-Mart Stores, Inc. v. Samara Bros.*, 529 U.S. 205, 214 (2000) (“[T]he producer can ordinarily obtain protection for a design that *is* inherently source identifying (if any such exists), but that does not yet have secondary meaning, by securing a design patent or a copyright for the design . . .”).

23. 81 U.S. (14 Wall.) 511 (1872).

24. *Id.* at 512; *see* U.S. Patent No. D1,440 (filed July 16, 1861).

25. *Gorham*, 81 U.S. (14 Wall.) at 512 & n.3.

two patents for similar designs.²⁶ Gorham sued in equity to enjoin White from the manufacture or sale of spoons or forks covered by White's patents.²⁷ White defended on the grounds that his designs did not infringe Gorham's.²⁸ The two designs, although similar, were not identical.²⁹ Experts for both sides testified as to the similarity *vel non* of the two designs.³⁰

Figure 1. Gorham and White Designs³¹

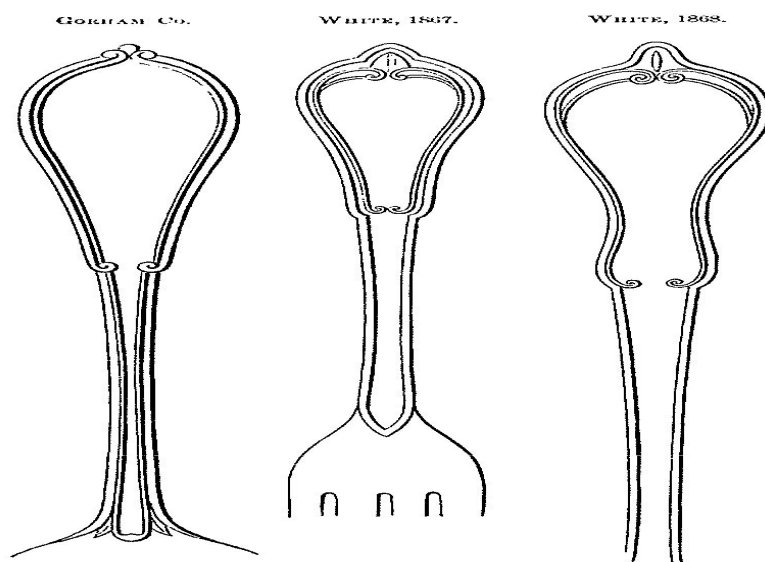

The Court held that a design patent protects “that which gives a peculiar or distinctive appearance to the manufacture, or article to which it may be applied, or to which it gives form.”³² In determin-

26. *Id.* at 512; see U.S. Patent No. D2,992 (filed Mar. 31, 1868); U.S. Patent No. D2,551 (filed Jan. 15, 1867).

27. *Gorham*, 81 U.S. (14 Wall.) at 512.

28. *Id.* at 512–13.

29. *See id.* at 520.

30. *Id.* at 513–18.

31. *Id.* at 521.

32. *Id.* at 525.

ing whether a design patent is infringed, “the controlling consideration is the resultant effect” of the design.³³ Therefore, the test for infringement turns on the “sameness of appearance,” and slight variations in the designs will not avoid infringement.³⁴ Turning to White’s contention that, for infringement to be found, an accused design must be indistinguishable from the patented design to an expert, the Court recognized that such a test would be extremely narrow.³⁵ The Court added:

It is [observers of ordinary acuteness] who are the principal purchasers of the articles to which designs have given novel appearances, and if they are misled, and induced to purchase what is not the article they supposed it to be . . . the patentees are injured, and that advantage of a market which the patent was granted to secure is destroyed.³⁶

Following this reasoning, the Court established the test for infringement of a design patent:

[I]f, in the eye of an ordinary observer, giving such attention as a purchaser usually gives, two designs are substantially the same, if the resemblance is such as to deceive such an observer, inducing him to purchase one supposing it to be the other, the first one patented is infringed by the other.³⁷

In *Smith v. Whitman Saddle Co.*,³⁸ the Supreme Court further elaborated on the test for infringement. The Whitman Saddle Company held a design patent for a saddle that was a combination of two older saddles: the cantle, or back, was the same as that of a Jenifer saddle, while the pommel, or front, was the same as that of Granger saddle, except that the pommel of the patented design fell off perpendicularly on its rear side.³⁹ Whitman Saddle Company sued Smith and Bourn for infringement of the patent.⁴⁰ The Smith saddle

33. *Gorham*, 81 U.S. (14 (Wall.) at 526.

34. *Id.* at 526–27.

35. *Id.* at 527.

36. *Id.* at 528.

37. *Id.*

38. 148 U.S. 674 (1893).

39. *Id.* at 676; see U.S. Patent No. D10,844 (filed Sept. 2, 1878).

40. *Whitman Saddle*, 148 U.S. at 675.

incorporated the Jenifer cantle and Granger pommel, but did not have the same perpendicular drop at the rear of the pommel as the patented design.⁴¹ The Court initially held that Whitman's combination of the Jenifer and Granger saddles was not patentable.⁴² However, the Court went on to address the issue of infringement, stating:

The shape of the front end being old, the sharp drop of the pommel at the rear seems to constitute what was new and to be material. . . . If, therefore, this drop were material to the design, and rendered it patentable as a complete and integral Whole, there was no infringement.⁴³

Although the Court's infringement analysis would come to be interpreted by lower courts as setting out a requirement that an accused design appropriate the patented design's point of novelty over the prior art, the Court set out no such requirement.

IV. THE PATH TO POINT OF NOVELTY

Early cases followed *Whitman Saddle* by comparing the patented design and the accused design taking into consideration the prior art, but did not impose the rigid point-of-novelty requirement that would come to characterize later cases. *Bevin Bros. Manufacturing Co. v. Starr Bros. Bell Co.*⁴⁴ was the first in the line of cases leading up to the point-of-novelty requirement. The design patent covered a bell with a body portion in the shape of an "oblate spheroid."⁴⁵ In determining whether the accused design infringed, the court stated that it "may avail itself of such common knowledge as is possessed by the

41. *Id.* at 682.

42. *Id.* at 681.

43. *Id.* at 682. The *Whitman Saddle* decision was issued before there was a statutory nonobviousness requirement. Had the statutory nonobviousness requirement been in place, the Court's analysis may have been different. See Perry J. Saidman, *What Is the Point of the Point of Novelty Test for Design Patent Infringement?*, 90 J. PAT. & TRADEMARK OFF. SOC'Y 401, 419 (2008) [hereinafter *What Is the Point*].

44. 114 F. 362 (C.C.D. Conn. 1902).

45. *Id.* at 362.

general public.”⁴⁶ It then determined that “[t]he shape of defendants’ bell differs from plaintiff’s more widely than plaintiff’s differs from the [prior art] door knob, and therefore defendants’ construction does not infringe the patent.”⁴⁷

Figure 2. Bevin Design⁴⁸



Similarly, in *Zidell v. Dexter*,⁴⁹ the Ninth Circuit looked to the prior art when the patented design was a combination of prior art designs. The patented design covered children’s clothing and was a combination of elements known in the prior art.⁵⁰ The accused designs brought together the same prior art elements in a different combination.⁵¹ The court found no infringement, stating that “[t]he differences in designs, which under the patent law will avoid infringement, are differences which will attract the attention of the ordinary observer, giving such attention as the purchaser usually

46. *Id.* at 363.

47. *Id.*

48. U.S. Patent No. 33,142 fig.1 (filed July 27, 1900) (arrows removed).

49. 262 F. 145 (9th Cir. 1920).

50. *Id.* at 146.

51. *Id.* at 147. The lower court found that one of the accused designs did infringe. *Id.* The defendant did not appeal this ruling. *Id.*

gives in buying articles of the kind in question and for the purposes for which they are intended.”⁵²

Figure 3. Zidell Design⁵³

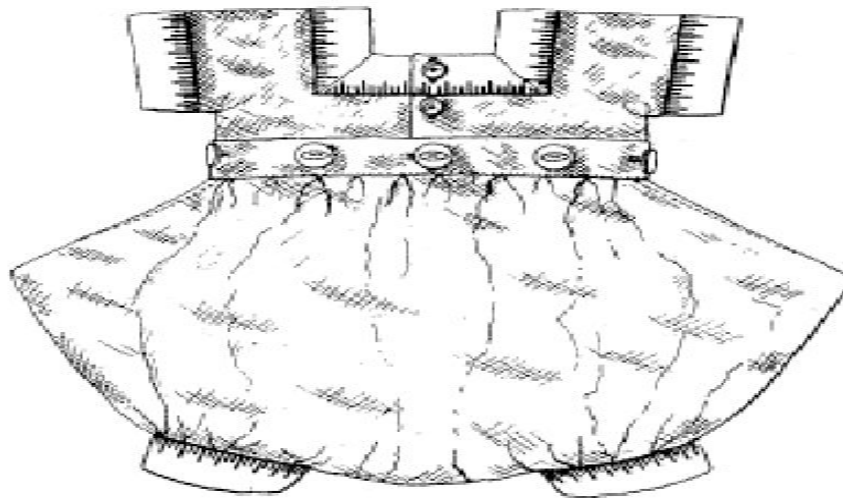

52. *Id.* In holding that the lower court was not in error by finding the patent valid, the court may have broken from the Supreme Court’s holding in *Whitman Saddle*. See *id.* at 146.

53. U.S. Patent No. D52,720 fig.2 (filed Aug. 12, 1918).

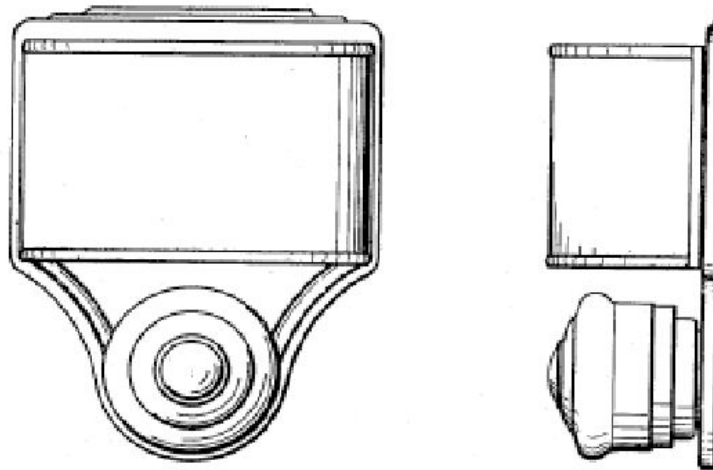
Figure 4. Applied Arts Design⁵⁴

Later decisions began imposing a requirement that an accused design appropriate the patented design's point of novelty to support a finding of infringement, but fell short of an explicit point-of-novelty test. *Applied Arts Corp. v. Grand Rapids Metalcraft Corp.*⁵⁵ is representative of such cases. The patented and accused designs were combination lighter/ashtrays for an automobile dashboard.⁵⁶ The Sixth Circuit recognized precedent stating that "a design patent is not infringed by anything which does not present the appearance which distinguishes the design claimed in the patent from the prior art."⁵⁷ Such an explicit requirement of an accused design's appropriation of the distinguishing characteristics of the patented design is more restrictive than *Gorham's* admonition that infringement is present when an ordinary observer would be deceived.⁵⁸ In attempting to reconcile the more restrictive rule with *Gorham*, the court held that "[t]he ordinary observer is not any observer, but one who, with less than the trained faculties of the expert, is a purchaser of things of

54. U.S. Patent No. D84,811 figs.1 & 2 (filed Dec. 20, 1930).

55. 67 F.2d 428 (6th Cir. 1933).

56. *Id.* at 428.

57. *Id.* at 429.

58. *Id.*

similar design, or one interested in the subject.”⁵⁹ Thus, “similitude of appearance is to be judged by the scope of the patent in relation to the prior art.”⁶⁰ Because the difference between the accused design and patented design was greater than the difference between the patented design and the prior art, the court found no infringement.⁶¹

The first case to set out an explicit point-of-novelty test in addition to the ordinary-observer test was *Sears, Roebuck & Co. v. Talge*. Foster L. Talge sued Sears, arguing that Sears had infringed his design patents on fruit juicers.⁶² The Eighth Circuit set out the test for design patent infringement:

The test of whether one design infringes another depends primarily upon whether the appearance of the two designs is substantially the same. The application of this test involves two considerations: first, to infringe, the identity of appearance, or sameness of effect as a whole upon the eye of an ordinary purchaser must be such as to deceive him, inducing him to purchase one, supposing it to be the other; and, second, to infringe, *the accused device must appropriate the novelty in the patented device which distinguishes it from the prior art.*⁶³

For support of a separate point-of-novelty test, the Eighth Circuit cited cases, including *Applied Arts* and *Whitman Saddle*, which mentioned a comparison of the patented design with the prior art but did not articulate a two-part test.⁶⁴ Despite the articulation of a second test for infringement, the Eighth Circuit applied the ordinary-observer test in the same way as *Applied Arts* and *Whitman Saddle* and found that there was no confusion under the ordinary-observer test.⁶⁵

59. *Id.* at 430 (internal quotation marks omitted).

60. *Id.* at 429.

61. *Applied Arts*, 67 F.2d at 430.

62. *Sears, Roebuck & Co. v. Talge*, 140 F.2d 395, 395 (8th Cir. 1944).

63. *Id.* at 395–96 (emphasis added) (citations omitted).

64. *Id.* at 396.

65. *Id.*

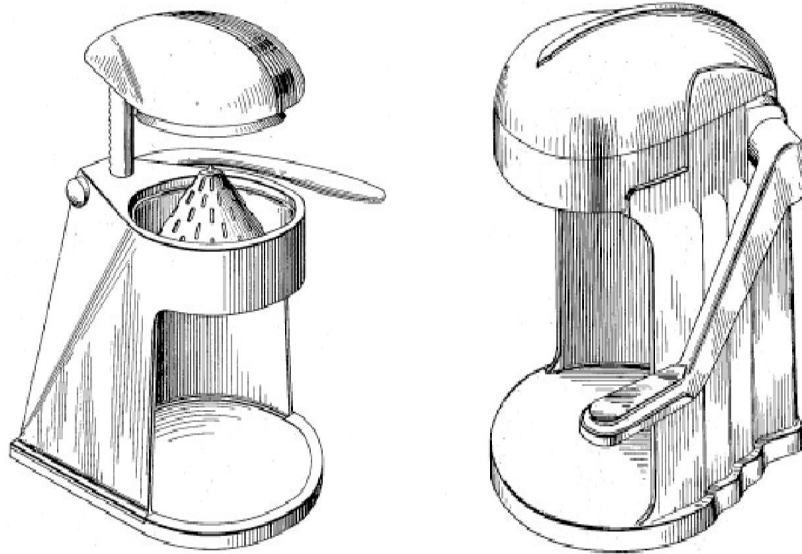
Figure 5. Talge Designs⁶⁶

V. LITTON SYSTEMS AND ITS AFTERMATH

The Federal Circuit first articulated a separate point-of-novelty test in *Litton Systems, Inc. v. Whirlpool Corp.* Litton Systems sued Whirlpool for infringement of design patent covering the design of microwave ovens and microwave oven doors.⁶⁷ Citing *Sears, Roebuck*, the Federal Circuit announced a point-of-novelty test separate from the ordinary-observer test.⁶⁸ In determining the point of novelty of the design, the court looked to the point of novelty as deter-

66. U.S. Patent No. D105,335 fig.1 (filed June 5, 1937); U.S. Patent No. D105,071 fig.1 (filed Apr. 30, 1937).

67. *Litton Sys., Inc. v. Whirlpool Corp.*, 728 F.2d 1423, 1427 (Fed. Cir. 1984). Litton also alleged infringement of a utility patent and violation unfair competition law. *Id.* The Federal Circuit held that the utility patent was invalid because the USPTO calculated the filing date as more than one year from the date of sale. *Id.* at 1436, 1440. The Federal Circuit ruled in favor of Whirlpool on the unfair competition claims. *Id.* at 1449.

68. *Id.* at 1444.

mined by the nonobviousness analysis.⁶⁹ The Whirlpool design featured none of these points of novelty; the court therefore held that there was no infringement.⁷⁰ Because there was no infringement under the point-of-novelty test, the Federal Circuit did not reach a determination on the ordinary-observer test.

Although the point-of-novelty test worked well when the patented design involved a single improvement over a single prior art reference, it was difficult to apply when the patented design involved multiple improvements over several different prior art references.⁷¹ In *Lawman Armor Corp. v. Winner International, LLC*,⁷² for instance, the Federal Circuit held that the point of novelty of a design could not consist of a combination of elements:

If the combination of old elements shown in the prior art is itself sufficient to constitute a “point of novelty” of a new design, it would be the rare design that would not have a point of novelty. The practical effect of Lawman’s theory would be virtually to eliminate the significance of the “points of novelty” test in determining infringement of design patents, and to provide patent protection for designs that in fact involve no significant changes from the prior art.⁷³

69. *Id.* The use of points of novelty as determined by the nonobviousness analysis allows for what is essentially an invalidity determination, only with a lower burden placed on the infringer. This backdoor invalidity attack is one of the main criticisms of the point-of-novelty analysis. See Brief of Amicus Curiae American Intellectual Property Law Ass’n in Support of Neither Party at 9–10, *Egyptian Goddess, Inc. v. Swisa, Inc. (Egyptian Goddess III)*, 543 F.3d 665 (Fed. Cir. 2008) (No. 2006-1562); Corrected Brief of Amicus Curiae Apple Inc. in Support of Neither Party (Supporting Reversal) at 18, *Egyptian Goddess III*, 543 F.3d 665 (No. 2006-1562). The problem is illustrated by *Litton Systems* itself, as the patent was held to be nonobvious. 728 F.2d at 1443.

70. *Litton Sys.*, 728 F.2d at 1444.

71. See, e.g., Brief of Amicus Curiae American Intellectual Property Law Ass’n in Support of Neither Party, *supra* note 69, at 8–9; Corrected Brief of Amicus Curiae Apple Inc. in Support of Neither Party (Supporting Reversal), *supra* note 69, at 25–26.

72. 437 F.3d 1383 (Fed. Cir. 2006).

73. *Id.* at 1386 (citing *Winner Int’l Corp. v. Wolo Mfg. Corp.* 905 F.2d 375, 376 (Fed. Cir. 1990)). Two years earlier, the Federal Circuit had upheld a district court’s ruling that the point of novelty of a design patent was a combination of

Additionally, the Federal Circuit often inconsistently applied the point-of-novelty test. In *Arminak & Associates, Inc. v. Saint-Gobain Calmar, Inc.*,⁷⁴ Arminak filed an action for a declaratory judgment of noninfringement of Calmar's patent on a "trigger sprayer shroud."⁷⁵ The Federal Circuit found one of the points of novelty to be a prominent horizontal line.⁷⁶ The court found the accused design contained this point of novelty, but it "result[ed] in a different overall design appearance."⁷⁷ Therefore, the court reasoned, the point of novelty was not appropriated.⁷⁸ This incorporation of the ordinary-observer test into the point-of-novelty test elevated the burden of proof in an infringement action even higher.

VI. EGYPTIAN GODDESS V. SWISA

A. District Court

Egyptian Goddess, Inc. (EGI) sued Swisa, Inc. and Dror Swisa, an individual, for infringement of a design patent on a nail buffer.⁷⁹ The patented design consisted of a hollow rectangular tube with exposed edges and buffers on three sides, the fourth side being bare.⁸⁰ The accused design was similar in appearance, except that it had four buffers, one on each side.⁸¹ At the trial court level, EGI argued that its design contained four elements—an open and hollow body,

three elements. See *Avia Group Int'l, Inc. v. L.A. Gear Cal., Inc.*, 853 F.2d 1557, 1565 (Fed. Cir. 1988). The court's break with precedent in *Lawman* was highly criticized. See generally Aaron Cook, Note, *Points of Novelty, Lawman Armor, and the Destruction of Design Patents!*, 12 J. TECH. L. & POL'Y 103 (2007); Daniel Adam Nadel, Note, *The Elusive Point of Novelty Test Leaves Design Patent Infringement in Limbo: A Critique of Lawman Armor Corporation v. Winner International, LLC*, 17 FED. CIR. B.J. 343 (2008).

74. 501 F.3d 1314 (Fed. Cir. 2007), *cert. denied*, 128 S. Ct. 2906 (2008).

75. *Id.* at 1318.

76. *Id.* at 1325.

77. *Id.* at 1326.

78. *Id.* The court cited no authority for this proposition.

79. *Egyptian Goddess, Inc. v. Swisa, Inc. (Egyptian Goddess I)*, No. 3:03-CV-0594-N, 2005 WL 5873510, at *1 (N.D. Tex. Dec. 14, 2005).

80. *Id.*

81. *Id.* at *2.

square cross-section, raised rectangular pads, and exposed corners—and that the point of novelty of the design was the combination of those four elements.⁸² At summary judgment, the district court found that the Nailco patent⁸³ contained all of the elements except a fourth side without a pad; the court also found that the fourth side without a pad was the point of novelty of EGI’s design.⁸⁴ The Swisa design did not contain this element, so the point of novelty was not appropriated.⁸⁵ The district court therefore granted Swisa’s motion for summary judgment on the issue of infringement.⁸⁶

Figure 6. EGI Design⁸⁷

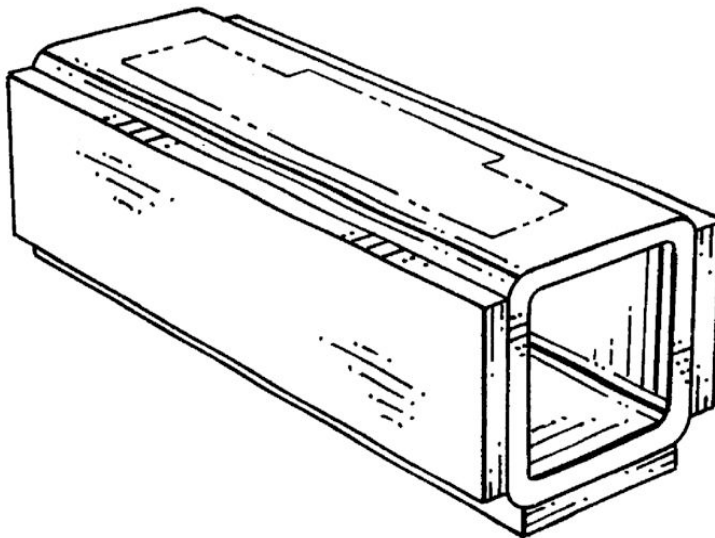

82. *Id.* at *2 & n.4.

83. U.S. Patent No. D416,648 (filed Aug. 17, 1998).

84. *Egyptian Goddess I*, 2005 WL 5873510, at *2.

85. *Id.*

86. *Id.*

87. U.S. Patent No. D467,389 fig.1 (filed Feb. 13, 2002).

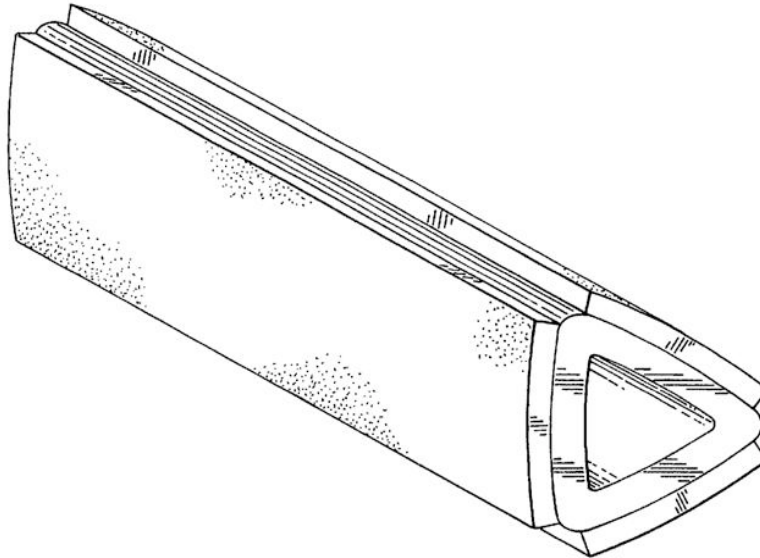
Figure 7. Nailco Patent⁸⁸

B. Panel Hearing

EGI appealed the district court's finding of noninfringement to the Federal Circuit.⁸⁹ The majority established a new rule requiring a combination to be "a non-trivial advance over the prior art" in order to constitute a point of novelty.⁹⁰ The new non-trivial advance test moved the point-of-novelty test even closer to the nonobviousness test. The majority shrugged off this consequence stating, "[d]esign patent law has already intertwined the infringement and validity tests."⁹¹ The majority then concluded that "no reasonable juror could conclude that EGI's asserted point of novelty constituted a non-trivial advance over the prior art," and upheld the lower court's granting of summary judgment to the defendant.⁹²

88. '648 Patent.

89. *Egyptian Goddess, Inc. v. Swisa, Inc. (Egyptian Goddess II)*, 498 F.3d 1354, 1355 (Fed. Cir. 2007).

90. *Id.* at 1357. In doing so, the majority distinguished *Lawman*, stating that it did not reject non-trivial advance test. *Id.* at 1357 n.2.

91. *Id.* at 1358 n.3.

92. *Id.* at 1358–59.

Judge Dyk dissented, stating that he would not have created the new non-trivial advance standard because it departed from precedent and was not addressed by either party.⁹³ Judge Dyk went on to point out the flaws of the non-trivial advance test. First, it “eviscerate[d] the statutory presumption of validity” because it placed the burden on the patentee to prove nonobviousness in order to show infringement.⁹⁴ Second, the test was too narrow because it applied only to design patents involving a combination of designs.⁹⁵ Third, the test was too broad because it extended an obviousness test to each individual point of novelty, not just the overall design.⁹⁶ Fourth, “it [was] almost impossible to determine whether a particular design feature represent[ed] a trivial or substantial advance over the prior art.”⁹⁷ Fifth, the new test was not supported by case law and was actually contrary to several Federal Circuit holdings.⁹⁸ Judge Dyk also pointed out that the non-trivial advance test was actually more restrictive than the nonobviousness test for validity because the non-trivial advance test did not take into account secondary considerations.⁹⁹ The Federal Circuit granted EGI’s petition for en banc rehearing, ordering the parties to address whether the point-of-novelty test should “be a test for infringement of design patent [sic].”¹⁰⁰

C. *En Banc*

At the en banc hearing, EGI argued that the ordinary-observer test alone could adequately address the concerns meant to be addressed by the point-of-novelty and non-trivial advance tests.¹⁰¹

93. *Id.* at 1359 (Dyk, J., dissenting).

94. *Id.*

95. *Egyptian Goddess II*, 498 F.3d at 1359 (Dyk, J., dissenting).

96. *Id.*

97. *Id.*

98. *Id.* at 1359–60.

99. *Id.* at 1359 n.1.

100. *Egyptian Goddess, Inc. v. Swisa, Inc.*, 256 F. App’x 357, 357 (Fed. Cir. 2007). The court also directed questions on specifics of the point-of-novelty test and what role claim construction should play in interpretation of design patents. *Id.* at 357–58.

101. *Egyptian Goddess, Inc. v. Swisa, Inc. (Egyptian Goddess III)*, 543 F.3d 665, 672 (Fed. Cir. 2008).

Swisa, on the other hand, argued that the Supreme Court had adopted the point-of-novelty test in *Whitman Saddle* and the Federal Circuit could not depart from it.¹⁰²

The Federal Circuit, in a unanimous opinion, first recognized that the point-of-novelty test was difficult to apply in cases that did not involve a single advance over a single prior art reference.¹⁰³ The court then held that the point-of-novelty test was inconsistent with *Gorham* and not mandated by *Whitman Saddle* or other precedent prior to *Litton Systems*.¹⁰⁴ The court stated that the point of novelty test was not mandated by *Whitman Saddle* because: (1) nothing in *Whitman Saddle* suggested a point of novelty test;¹⁰⁵ and (2) cases immediately subsequent to *Whitman Saddle* interpreted it as requiring a comparison between the patented design and the prior art, without the requirement of a specific point of novelty.¹⁰⁶

The court also held that the ordinary-observer test, as set out in *Whitman Saddle*, was sufficient to guard against expansive assertions of design patent rights.¹⁰⁷ A comparison between the patented design, the accused design, and the prior art was sufficient to determine if an ordinary observer would be deceived.¹⁰⁸ Furthermore, the ordinary-observer test avoided the problems inherent in the point-of-novelty test.¹⁰⁹

Specifically, according to the court, the point-of-novelty test incorrectly focused only on specific aspects of a design, rather than the design as a whole.¹¹⁰ Furthermore, the more novel the design, the more difficult it was to determine a point of novelty.¹¹¹ Additionally, the case law was never clear as to what extent combinations of

102. *Id.*

103. *Id.* at 671.

104. *Id.* at 672.

105. *Id.* at 673.

106. *Id.* at 674–75.

107. *Egyptian Goddess III*, 543 F.3d at 676.

108. *Id.* at 676–77.

109. *Id.* at 677; *see also* Brief of Amicus Curiae American Intellectual Property Law Ass'n in Support of Neither Party, *supra* note 69; Corrected Brief of Amicus Curiae Apple Inc. in Support of Neither Party (Supporting Reversal), *supra* note 69.

110. *Egyptian Goddess III*, 543 F.3d at 677.

111. *Id.*

prior art elements constituted a point of novelty.¹¹² Notably, the Federal Circuit did not mention that the point-of-novelty test had become a backdoor invalidity attack. For these reasons, the Federal Circuit rejected the point-of-novelty test along with the non-trivial advance test.¹¹³

In place of the point-of-novelty test, the Federal Circuit announced that the ordinary-observer test would remain in place with a slight modification: the factfinder would also consider the prior art.¹¹⁴ Under this modified ordinary-observer test, a court first examines the patented and accused designs.¹¹⁵ If the two designs “are not plainly dissimilar,” the factfinder should compare the two designs in light of the prior art.¹¹⁶ According to the court, this modification of the ordinary-observer test more closely followed the analysis of *Whitman Saddle* and subsequent circuit court decisions.¹¹⁷ The court placed the burden on the patentee to prove infringement, but the burden was placed on the accused infringer to produce prior art references that show an ordinary observer would not be confused.¹¹⁸ Despite the Federal Circuit’s elimination of the point-of-novelty test, the court still ruled against EGI.¹¹⁹ The court held that ordinary purchasers of nail buffers distinguished between those buffers with three pads and those with four pads; accordingly, an ordi-

112. *Id.*; see *supra* note 73 and accompanying text.

113. *Egyptian Goddess III*, 543 F.3d at 678.

114. *Id.* This test has been dubbed the “3-way Visual Comparison” test. See *What Is the Point*, *supra* note 43, at 412–13. Both the AIPLA and Apple amicus briefs argued eloquently for taking into account the prior art while applying the ordinary-observer test. See Brief of Amicus Curiae American Intellectual Property Law Association in support of Neither Party, *supra* note 69; Corrected Brief of Amicus Curiae Apple Inc. in Support of Neither Party, *supra* note 69.

115. *Egyptian Goddess III*, 543 F.3d at 678.

116. *Id.*

117. *Id.*

118. *Id.* at 678–79. Additionally, the Federal Circuit held that district courts need not verbally construe design patents as a prerequisite to infringement analysis. *Id.* at 679. This holding may make proving infringement easier. See Perry J. Saidman & Allison Singh, *The Death of Gorham Co. v. White: Killing It Softly with Markman*, 86 J. PAT. & TRADEMARK OFF. SOC’Y 792 (2004).

119. *Egyptian Goddess III*, 543 F.3d at 682.

nary observer would not believe the accused design to be the same as the patented design.¹²⁰

VII. THE EFFECT OF THE ABOLITION OF THE POINT-OF-NOVELTY TEST

The Federal Circuit's rejection of the point-of-novelty test has been hailed as a victory for design patent holders,¹²¹ but how great of an impact will it have on design infringement analysis? It would be incorrect to assume that, under *Egyptian Goddess*, all previous cases that found infringement under the ordinary-observer test, but not the point-of-novelty test, would come out in favor of the patent holder. Courts, in their application of the ordinary-observer test, often did not take any account of the prior art. Although there will undoubtedly be benefits for those designs that do not have an easily articulated point of novelty, there will also be designs in a crowded field of prior art that are not infringed under either the point-of-novelty and the post-*Egyptian Goddess* ordinary-observer standard. Only when more cases using the new ordinary-observer test are handed down will one definitively be able to determine the effect that *Egyptian Goddess* will have on design patent law. However, by reexamining those cases that have already been decided under the old standard, one may be able to formulate an educated guess. In this spirit, this section will first analyze the first cases to apply the new ordinary-observer test. Then, with those analyses in mind, this Note will examine *Torspo Hockey International, Inc. v. Kor Hockey Ltd.*¹²²

120. *Id.* The Federal Circuit denied EGI's petition for rehearing without opinion. EGI petitioned the U.S. Supreme Court for a writ of certiorari, arguing that "the Federal Circuit erred by failing to hold that when the patented and accused designs are compared in light of the prior art designs, the comparison is to be conducted by viewing the visual effect of each design *as a whole*." Petition for Writ of Certiorari at 6, *Egyptian Goddess, Inc. v. Swisa, Inc. (Egyptian Goddess IV)*, 129 S. Ct. 1917 (2009) (No. 08-1031). The Supreme Court denied certiorari. *Egyptian Goddess IV*, 129 S. Ct. at 1917.

121. See *Exposed!*, *supra* note 1, at 860 ("The U.S. Court of Appeals for the Federal Circuit . . . has provided some long-needed relief for design patent owners."); Hanovice, *supra* note 1, at S3 ("Design patent holders have reason to celebrate . . .").

122. 491 F. Supp. 2d 871 (D. Minn. 2007).

and *Fisher-Price, Inc. v. Safety 1st, Inc. (Fisher-Price II)*,¹²³ two pre-*Egyptian Goddess* infringement cases where the patentee satisfied the ordinary-observer test, but not the point-of-novelty test.

A. *Post-Egyptian Goddess*

The first design patent infringement case decided after *Egyptian Goddess*, *Arc'teryx Equipment, Inc. v. Westcomb Outerwear, Inc.*,¹²⁴ may be indicative of how infringement analyses will be conducted in the future. Arc'teryx brought suit against Westcomb for infringement of the D513,715 Patent¹²⁵ for a jacket zipper.¹²⁶ On Westcomb's summary judgment motion, the court found no infringement.¹²⁷ The court first determined that the ordinary observer consisted of "an outdoor clothing customer who is more discerning that [sic] an average retail shopper."¹²⁸ Taking notice of the Federal Circuit's deviation from requiring a verbal description, the district court instead focused on the impression that the two zippers would leave on the ordinary observer.¹²⁹ The court stated: "An ordinary observer of the '715 patent would be left with the impression that the zipper contains two sections An ordinary observer of Defendant's product would be left with the impression that Defendant's zipper consists of three sections" ¹³⁰ The placement of the diagonal sections, the length of the diagonal sections, and the lengths of the straight sections were also taken into account.¹³¹ Examining the prior art, the court found that the patented design was closer to the Lowe Alpine's Black Ice Jacket, which was prior art, than it was to the accused design.¹³² Therefore, there was no infringement.¹³³

123. 109 F. App'x 387 (Fed. Cir. 2004).

124. No. 2:07-CV-59 TS, 2008 WL 4838141 (D. Utah Nov. 4, 2008).

125. U.S. Patent No. D513,715 (filed Aug. 10, 2004).

126. *Arc'teryx Equip.*, 2008 WL 4838141, at *1.

127. *Id.* at *3.

128. *Id.* at *2.

129. *Id.* at *2-3.

130. *Id.* at *2.

131. *Id.* at *3.

132. *Arc'teryx Equip.*, 2008 WL 4838141, at *3.

133. *Id.*

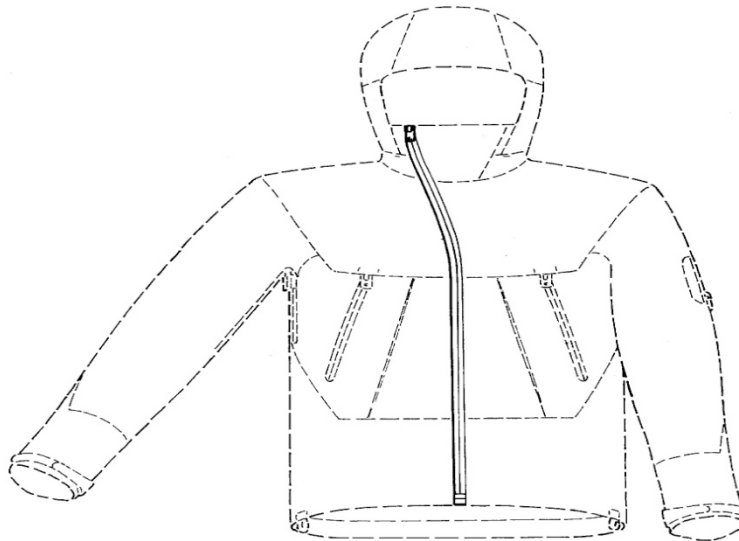
Figure 8. Arc'teryx Design¹³⁴

International Seaway Trading Corp. v. Walgreens Corp.,¹³⁵ also applied the new ordinary-observer test. International Seaway sued Walgreens and a supplier for infringement of three patents for the design of a clog.¹³⁶ Walgreens moved for summary judgment, arguing that International Seaway's patents were anticipated by two models of shoes made by Crocs, Inc.¹³⁷ Applying the ordinary-observer test, the court found that "[t]he actual shape of the overall shoe and the sole is nearly identical between the two shoes."¹³⁸ The slight variations in the number and location of holes on the sole of the shoe were not enough for an ordinary observer to get a different

134. U.S. Patent No. D513,715 fig.1 (filed Aug. 10, 2004).

135. 599 F. Supp. 2d 1307 (S.D. Fla. 2009).

136. *Id.* at 1310. The patents owned by Seaway were: U.S. Patent No. D545,033 (filed Feb. 16, 2006); U.S. Patent No. D545,032 (filed Feb. 1, 2006); U.S. Patent No. D529,263 (filed Feb. 18, 2005).

137. *Int'l Seaway Trading*, 599 F. Supp. 2d at 1312. Although this case deals with anticipation, the analysis is the same as infringement analysis under the maxim "that which infringes if later, anticipates if earlier." *See, e.g.,* SmithKline Beecham Corp. v. Apotex Corp., 403 F.3d 1331, 1343 (Fed. Cir. 2005); *Lewmar Marine, Inc. v. Bariant, Inc.*, 827 F.2d 744, 747 (Fed. Cir. 1987).

138. *Int'l Seaway Trading*, 599 F. Supp. 2d at 1318.

impression.¹³⁹ Because International Seaway's patents were not novel, the court held that they were invalid.¹⁴⁰

Figure 9. International Seaway Design¹⁴¹

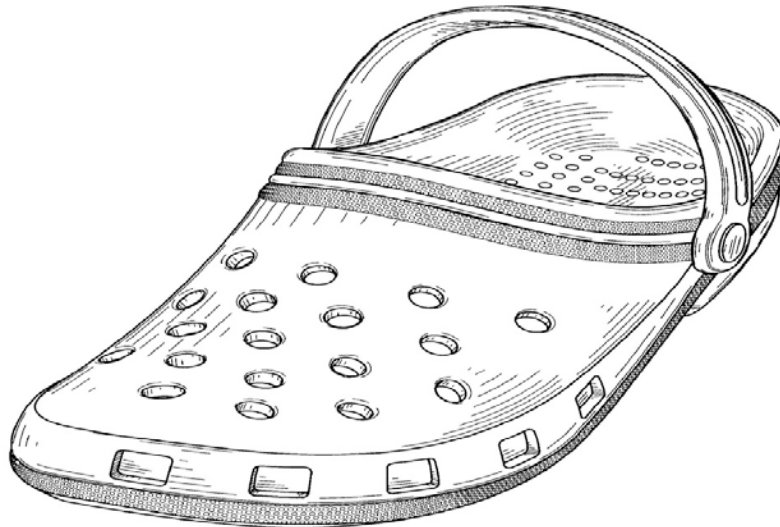

139. *Id.* at 1318–19.

140. *Id.* at 1319. If the court examined any prior art of the Crocs design, it was not mentioned in the opinion. However, the Crocs patents were sufficiently distinct from the prior art that the outcome would most likely have been the same. *See* U.S. Patent No. D517,789 (filed May 28, 2004). A third case has applied the post-*Egyptian Goddess* ordinary-observer standard. *See* Minka Lighting, Inc. v. Maxim Lighting Int'l, Inc., No. 3:06-CV-995-K, 2009 WL 691594 (N.D. Tex. Mar. 16, 2009). This case is not very instructive, however, as the court determined that the accused designs were sufficiently dissimilar to the patented designs that no comparison to the prior art was necessary. *See id.* at *8.

141. '263 Patent fig.1.

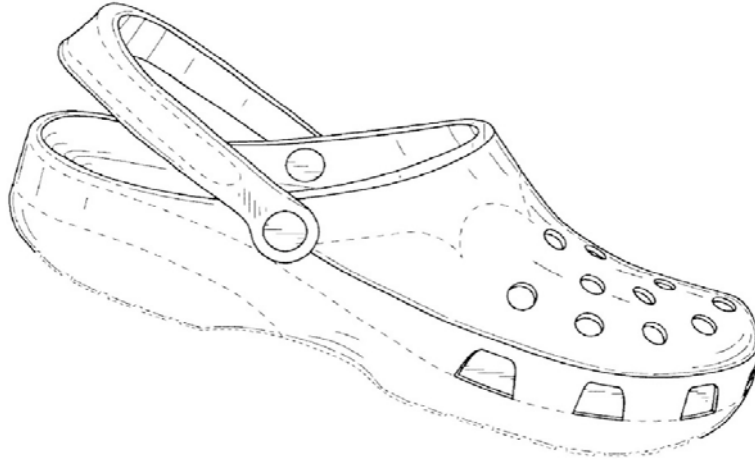
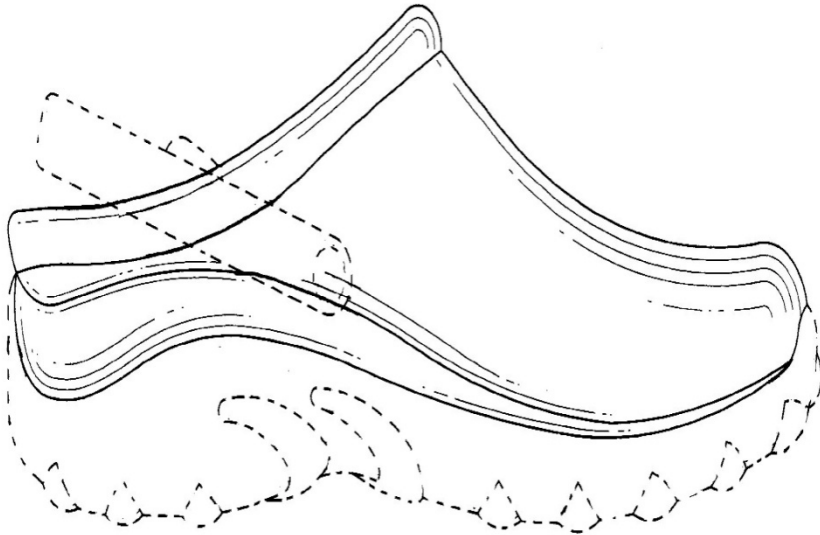
Figure 10. Crocs Design¹⁴²Figure 11. Prior Art¹⁴³

142. '789 Patent fig. 1.

143. U.S. Patent No. D479,906 (filed Apr. 4, 2003).

B. Pre-Egyptian Goddess

Torspo Hockey International, Inc. v. Kor Hockey Ltd., is illustrative of the odd results that sometimes occurred when the point-of-novelty test was used as a backdoor validity test. Torspo sought a declaratory judgment that Kor's D514,505 Patent¹⁴⁴ was invalid and not infringed.¹⁴⁵ In response, Kor sought a preliminary injunction against Torspo forbidding the selling, making, using, or distributing of certain models of Torspo skates.¹⁴⁶ To obtain the injunction, Kor was required to show, *inter alia*, that it was reasonably likely to prove that Torspo was infringing.¹⁴⁷ Applying the ordinary-observer test, the court found that an ordinary observer would consider the accused design and patented design to be substantially the same.¹⁴⁸ However, the court found that the shape of the skate was "in fact, not novel."¹⁴⁹ The court reached this conclusion because Kor carried the burden of proving the points of novelty.¹⁵⁰ Because Kor was unlikely to show a point of novelty, the court denied its motion for a preliminary injunction.¹⁵¹

Although Kor was unable to show a reasonable likelihood of success on the merits for infringement, the court analyzed whether Torspo raised a substantial question as to the patent's validity.¹⁵² The court found that '505 Patent was sufficiently distinct from the prior art that there was not a substantial question as to invalidity for obviousness or anticipation.¹⁵³

Although not a final judgment, *Torspo* is demonstrative of one of the major flaws of the point-of-novelty test: its use as a backdoor invalidity attack. Torspo was unable to prove anticipation because of the heightened proof requirements. Kor, however, was left with a

144. U.S. Patent No. D514,505 (filed Sept. 20, 2004).

145. *Torspo Hockey Int'l, Inc. v. Kor Hockey Ltd.*, 491 F. Supp. 2d 871, 873 (D. Minn. 2007).

146. *Id.*

147. *Id.*

148. *Id.* at 877.

149. *Id.* at 877–78.

150. *Id.* at 878.

151. *Torspo*, 491 F. Supp. 2d at 879.

152. *Id.*

153. *Id.* at 881.

valid patent that was completely unenforceable. This result was a direct result of two factors. First, the burden was on Torspo to prove anticipation,¹⁵⁴ while Kor had the burden to establish points of novelty.¹⁵⁵ Second, the court could consider a combination of elements when examining novelty, but the point-of-novelty test required the elements to be examined individually.¹⁵⁶

Under the new ordinary-observer test, however, the court's determination of infringement likely would have been different. The prior art cited by Torspo pertained to inline skates as well as ice skates.¹⁵⁷ These designs contained the arch disclosed in the '505 Patent, but none of the designs disclosed "the high heel profile, the sloped downward transition from the high profile at the heel toward the mid-foot portion, [and] the relatively shallow profile from the mid-foot forward to the toe."¹⁵⁸ The '505 design therefore "departs conspicuously from the prior art."¹⁵⁹ The accused design, on the other hand, is identical to the patented design. Comparing the two designs, an ordinary observer familiar with skates would not be able to distinguish the two. Under the new ordinary-observer test, the Torspo skate would be infringing.

In *Fisher-Price, Inc. v. Safety 1st, Inc.*, the plaintiff, Fisher-Price, brought an infringement suit against various competitors for in-

154. *Id.* at 880–81.

155. *Id.* at 879.

156. *Id.* at 880 n.6 (citing *L.A. Gear, Inc. v. Thom McAn Shoe Co.*, 988 F.2d 1117, 1124 (Fed. Cir. 1993)). The district court mentioned how this incongruity between the novelty and point-of-novelty tests could lead to the bizarre result of a design patent being novel, but lacking a point of novelty. *Id.* The same type of incongruity may still be present in the modified ordinary-observer test set out in *Egyptian Goddess*. See *Exposed!*, *supra* note 1, at 883–84. Mr. Saidman, who also authored Apple's amicus brief for the *Egyptian Goddess* en banc rehearing, argues that a hypothetical Swisa design patent application for its nail buffer would be denied as obvious. *Id.* at 884. Since the test for obviousness is under the designer skilled in the art standard, and a designer skilled in the art would have a more discerning eye than an ordinary observer, the Federal Circuit's holding that the Swisa buffer did not infringe appears to be untenable. *Id.*

157. See U.S. Patent No. 6,267,411 (filed Oct. 6, 1998); U.S. Patent No. 6,186,519 (filed Sept. 11, 1998); U.S. Patent No. 5,855,380 (filed Dec. 9, 1996).

158. *Torspo*, 491 F. Supp. 2d at 880 (alteration in original).

159. *Egyptian Goddess, Inc. v. Swisa, Inc. (Egyptian Goddess III)*, 543 F.3d 665, 677 (Fed. Cir. 2008).

fringement of several patents pertaining to carriers, strollers, and bassinets for infants.¹⁶⁰ Of the five patents at issue, one, D431,940,¹⁶¹ was a design patent for the cover of a bassinet. The only prior art considered by the trial court was a prototype designed by Scott Ziegler.¹⁶² A jury found the patent valid and infringed, and the district court denied the defendant's motion for judgment as a matter of law.¹⁶³ On appeal, the Federal Circuit overturned the verdict, stating that Fisher-Price failed to establish a point of novelty over the prior art.¹⁶⁴

Even under the new ordinary-observer test, this decision would likely go against Fisher-Price. The accused design is actually more similar to the Zeigler prior art than it is to the '940 patent.¹⁶⁵ In order to prove infringement, Fisher-Price would have to undermine the validity of its '940 patent by arguing against the novelty of the '940 patent over the Zeigler prior art. As in *Applied Arts*, the "similitude of appearance" between the patented and accused design is not enough to create "sameness of effect upon the eye" when viewed in relation to the prior art.¹⁶⁶

160. Fisher-Price, Inc. v. Safety 1st, Inc. (*Fisher-Price I*), 279 F. Supp. 2d 530, 536 (D. Del. 2003), *aff'd in part, rev'd in part, modified in part*, 109 F. App'x 387 (Fed. Cir. 2004).

161. U.S. Patent No. D431,940 (filed May 14, 1999).

162. *Fisher-Price I*, 279 F. Supp. 2d at 543.

163. *Id.* at 542–47.

164. Fisher-Price, Inc. v. Safety 1st, Inc. (*Fisher-Price II*), 109 F. App'x 387, 394 (Fed. Cir. 2004). The Federal Circuit stated that Fisher-Price could not point to any testimony identifying a point of novelty. *Id.* On the defendants' motion for judgment as a matter of law following the jury verdict, the district court stated "Fisher-Price adduced expert testimony suggesting that the points of novelty of the '940 patent consisted of the dome and its ornamental features." *Fisher-Price I*, 279 F. Supp. 2d at 545. The Federal Circuit did not elaborate on this contradiction. An examination of the record reveals that the district court erroneously cited to a witness's testimony that did not attempt to compare the patented design with the prior art. See Brief for Appellants Safety 1st, Inc., et al. at 48, *Fisher-Price II*, 109 F. App'x 387 (No. 03-1644).

165. See Brief for Appellants Safety 1st, Inc., et al., *supra* note 164, at 47.

166. *Applied Arts Corp. v. Grand Rapids Metalcraft Corp.*, 67 F.2d 428, 429–30 (6th Cir. 1933).

VIII. CONCLUSION

Egyptian Goddess undoubtedly was a victory for design patent owners. The point-of-novelty test, which had no basis in Supreme Court precedent, imposed a high standard on holders of design patents in order to prove infringement. Additionally, the point-of-novelty test had the effect of forcing plaintiffs to prove that their design patents were enforceable. But the Federal Circuit's ruling will not affect all design patents equally. In particular, those patents that are sufficiently distinct from the prior art that the determination of a point of novelty is difficult, if not impossible, will receive significantly more protection after *Egyptian Goddess*. Additionally, those designs that are exactly copied by an infringer will no longer be rendered unenforceable merely because a court determines that the design has no point of novelty.