

TEKNOTES TASARIM

Slaughterhouse Systems

Meat Technologies *Et Teknolojileri*

2022
SLAUGHTER SOLUTIONS

GET IN TOUCH



+90 555 893 98 01
+90 546 844 09 04



bilgi@mezbaha.com
www.mezbaha.com



Sekerpinar Street, Defne Cayirova
Region Kocaeli/Istanbul-TURKEY

CATTLE BÜYÜKBAŞ



TEKNOTES CUSTOM DESIGNS, MANUFACTURES
INSTALLS CATTLE SLAUGHTERING SYSTEMS



MANUFACTURING İMALATÇI



TEKNOTES , manufactures all the cattle equipment needed for a slaughterhouse from paddock to slaughtering box, to slaughtering lines equipment and processing units, by conveying the 11 years of experience in manufacturing systems to your project.

TEKNOTES, imalat sistemlerindeki 11 yıllık tecrübesini projenize aktararak, padoktan kesim hücreğine, kesim hattı ekipmanları ve işleme ünitelerine kadar bir kesimhanenin ihtiyacı olan tüm büyükbaş hayvan ekipmanlarını üretmektedir.



TEKNOTES manufactures all the products to be used in slaughterhouse projects
Mezbaha projelerinde kullanılacak tüm ürünleri TEKNOTES üretmektedir



TEKNOTES CUSTOM DESIGNS,
MANUFACTURES AND INSTALLS
CATTLE SLAUGHTERING SYSTEMS

BÜYÜKBAŞ MEZBAHANE SİSTEM ve EKİPMANLARI CATTLE SLAUGHTERHOUSE SYSTEMS and EQUIPMENTS

DAİRESEL KESİM HÜCRESİ

KLASİK KESİM HÜCRESİ
SIĞIR KANAMA KANCASI
SIĞIR KANAMA VİNCİ
SIĞIR KANAMA HATTI
SIĞIR AKTARMA VİNCİ
HAREKETLİ KASAP PLATFORMLARI
GERİ DÖNÜŞ VE KANCA İNDİRME APARATI
SIĞIR İŞLEME KONVEYÖRÜ
HİDROLİK DERİ YÜZME MAKİNASI
HİDROLİK İÇÖRGAN ÇIKARTMA PLATFORMU
SIĞIR İŞLEME KANCASI
BÜYÜKBAŞ DUŞLAMA KABİNİ
ET İNDİRME ÇEYREKLEME ELEVATÖRÜ
ÇEYREKLEME MAKASI
KARKAS YÜKLEME KOLU
SIĞIR KANAMA TAVASI
DÖŞ AÇMA TESTERESİ
KARKAS BÖLME TESTERESİ
DERİ BANT KONVEYÖRÜ
KELLE AYAK BANT KONVEYÖRÜ
SAKATAT KONVEYÖRÜ
BACAĞI AÇMA VE KİTLEME EKİPMANI
TİLLE
AYAK & BOYNUZ KESME MAKASI
KELLE YIKAMA KABİNİ

ROTATIONARY RITUAL TRAP (KILLING BOX)

CLASSIC CUTTING CABIN
CATTLE BLEEDING HOOK
CATTLE BLEEDING HOIST
CATTLE BLEEDING LINE
CATTLE TRANSFER ELEVATOR
MOBILE BUTCHER PLATFORMS
RETURN AND HOOK LOWERING APPARATUS
CATTLE PROCESSING CONVEYOR
SKIN DEHIDER MACHINE
VISCERA REMOVAL PLATFORM
CATTLE PROCESSING HOOK
CATTLE SHOWER CABIN
MEAT LOWERING AND QUARTERING ELEVATOR
QUARTERS SAW
CARCASS LOADING ARM
CATTLE BLEEDING PAN
BRISKET OPENING SAW
CARCASS SPLITTING SAW
SKIN BELT CONVEYOR
HEAD FOOT BELT CONVEYOR
OFFAL CONVEYOR
LEG OPENING AND LOCKING EQUIPMENT
TILL
HORN & FOOT CUTTING SAW
HEAD WASH CABINET



ROTATIONARY RITUAL TRAP (KILLING BOX) DAİRESEL KESİM HÜCRESİ

Engine Power: 4 kW / 5.2 hp
Weight: 3000 kg
Length: 2000mm
Width: 2600 mm
Length: 2500 mm
Pressure: 6-8 Bar

Motor Gücü: 4 kW / 5.2 hp
Ağırlık: 3000 kg
Uzunluk: 2000 mm
En: 2600 mm
Boy: 2500 mm
Basınç: 6-8 Bar



It is fully automatic and appropriate for halal slaughtering.
The animal is taken in the equipment from the back door.

Tam otomatiktir. Helal kesime ve işçi sağlığı-güvenliği
kriterlerine uygundur.

CATTLE STUNNING BOX KLASİK KESİM HÜCRESİ

Height: 2800mm
Width: 1000 mm
Length: 2500 mm
Pressure: 6 Bar

Yükseklik: 2800 mm
En: 1000 mm
Boy: 2500 mm
Basınç: 6 Bar



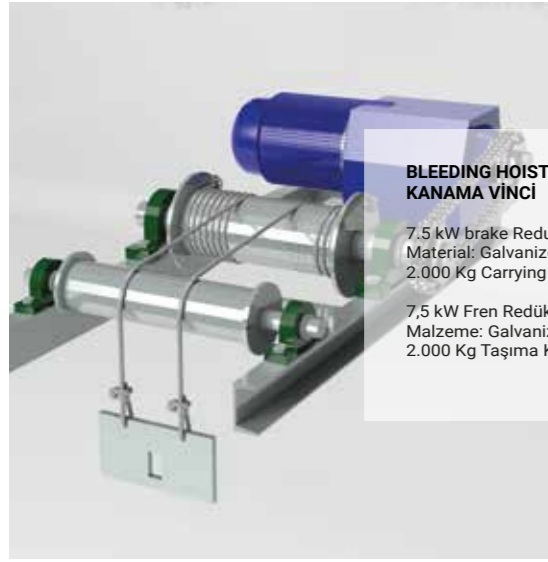

**BLEEDING HOIST
KANAMA VİNCİ**

7,5 kW brake Reducer Motor
Material: Galvanized
2.000 Kg Carrying Capacity

7,5 kW Fren Redüktörlü Motor
Malzeme: Galvanizli
2.000 Kg Taşıma Kapasitesi

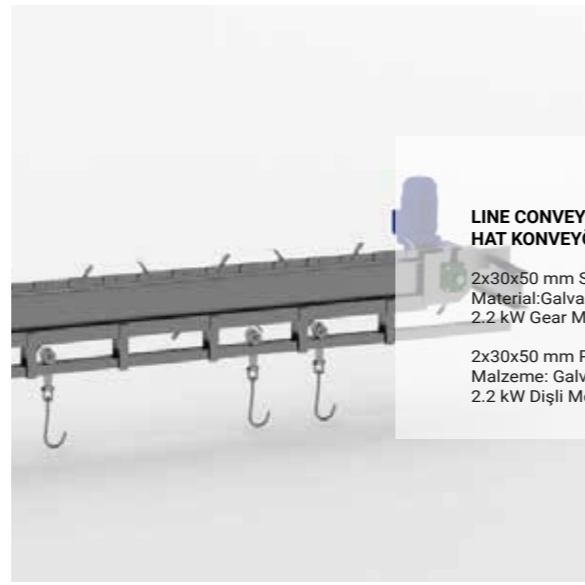

**LINE CONVEYOR
HAT KONVEYÖRÜ**

2x30x50 mm Stainless
Material:Galvanized Body
2.2 kW Gear Motor

2x30x50 mm Paslanmaz
Malzeme: Galvanizli Gövde
2.2 kW Dişli Motor



**CARCASS LOADING ARM
KARKAS YÜKLEME KOLU**

Material: Stainless-Galvanized
System: Hydraulic-Pneumatic
270° Mobility

Malzeme: Paslanmaz-Galvanizli
Sistem: Hidrolik-Pnömatik
270° Hareketlilik



**MEAT LOWERING QUARTERING
ELEVATOR
ET İNDİRME VE ÇEYREKLEME
ELEVATÖRÜ**

Lowering ¼ Carcasses of 45°
1.5 kW Gear Motor
Material: Galvanized

¼ Karkasların 45° düşürülmesi
1.5 kW Dişli Motor
Malzeme: Galvanizli



**TRANSFER UNIT
AKTARMA ÜNİTESİ**

Hydraulic-Pneumatic System
1,500-2,000 Kg Carrying Capacity
Stainless

Hidrolik-Pnömatik Sistem
1.500-2.000 Kg Taşıma Kapasitesi
Paslanmaz



**HOOK LOWERING HELIX
KANCA İNDİRME HELEZONU**

45° Hook Lowering Apparatus
1.5 kW Reducer Motor
Material: Galvanized

45° Kanca İndirme Aparatı
1.5 kW Redüktörlü Motor
Malzeme: Galvanizli

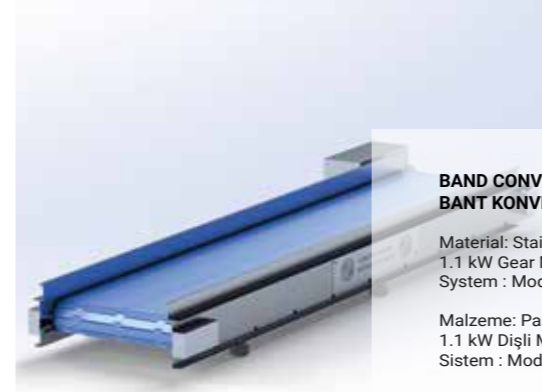

**BAND CONVEYOR
BANT KONVEYÖRÜ**

Material: Stainless
1.1 kW Gear Motor
System : Modular Tape

Malzeme: Paslanmaz
1.1 kW Dişli Motor
Sistem : Modüler Bant



**BUTCHER PLATFORM
KASAP PLATFORMU**

Material: Stainless-Galvanized
System: Hydraulic-Pneumatic
Capacity: Min.200 Kg

Malzeme: Paslanmaz-Galvanizli
Sistem: Hidrolik-Pnömatik
Kapasite: Min.200 Kg



**SKIN DEHIDER MACHINE
DERİ YÜZME MAKİNESİ**

Capacity: 40 Skinning Per Hour
System: Hydraulic
Stainless & Galvanized

Kapasite: Saatte 40
Sistem: Hidrolik
Paslanmaz ve Galvanizli



**EXTRACTION PLATFORM
İÇ ORGAN ÇIKARMA PLAT.**

Moving Platform
System: Hydraulic-Pneumatic
Material: Stainless

Hareketli platform
Sistem: Hidrolik-Pnömatik
Malzeme: Paslanmaz



SHEEP KÜÇÜKBAŞ

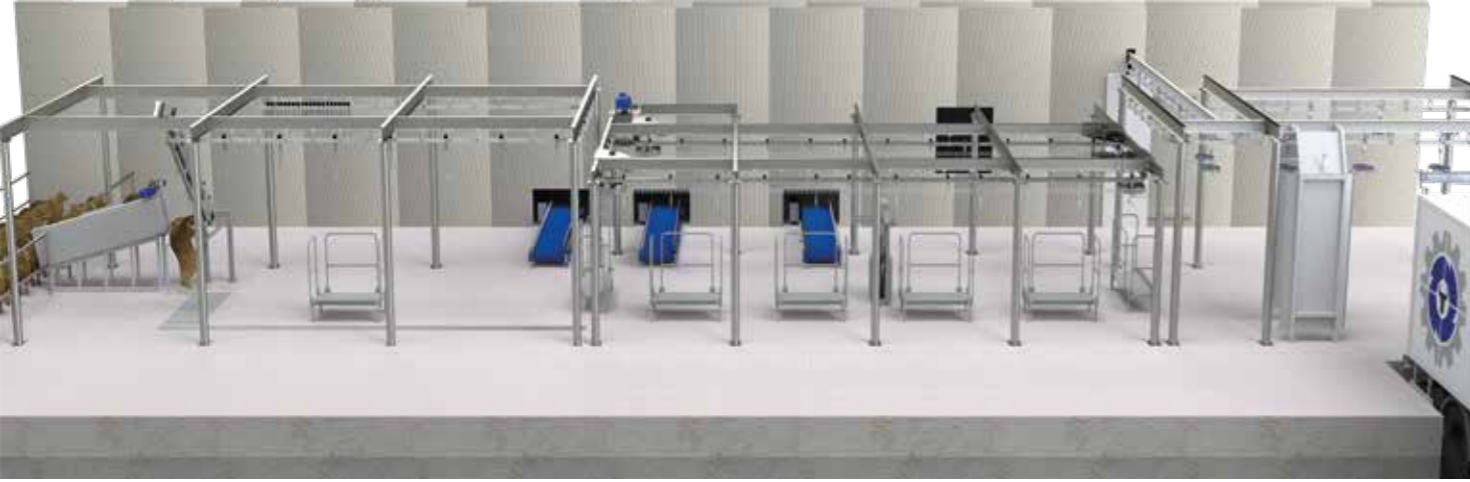

**TEKNOTES CUSTOM DESIGNS, MANUFACTURES
INSTALLS SHEEP SLAUGHTERING SYSTEMS**



MANUFACTURING İMALATÇI



TEKNOTES , manufactures all the sheep equipment needed for a slaughterhouse from paddock to slaughtering box, to slaughtering lines equipment and processing units,by conveying the 11 years of experience in manufacturing systems to your project.

TEKNOTES, imalat sistemlerindeki 11 yıllık tecrübesini projenize aktararak, padoktan kesim hücreesine, kesim hattı ekipmanları ve işleme ünitelerine kadar bir kesimhanenin ihtiyacı olan tüm küçükbaş hayvan ekipmanlarını üretmektedir.



*TEKNOTES manufactures all the products to be used in slaughterhouse projects
Mezbaha projelerinde kullanılacak tüm ürünleri TEKNOTES üretmektedir*

KÜÇÜKBAŞ MEZBAHANE SİSTEM ve EKİPMANLARI
SHEEP SLAUGHTERHOUSE SYSTEMS and EQUIPMENTS



SHEEP & GOAT

TEKNO CUSTOM DESIGNS,
MANUFACTURES AND INSTALLS
SHEEP SLAUGHTERING SYSTEMS.



TEKNO TASARIM MAKİNE
MEZBAHA SİSTEMLERİ



SHEEP FIXING MACHINE

It is made of stainless steel, with adjustable width, it can be used for every kind of sheep. After placing the sheep in the platform, it is elevated to the highest level with the movable conveyor. Following the slaughter by the butcher, the sheep is transferred to the bleeding pan

SHEEP LIFTING ELEVATOR

Slaughtered sheep is transferred to the bleeding conveyor by sheep lifting elevator.

BLEEDING CONVEYOR

Slaughtered sheeps bleed and move towards processing section on this automatic conveyor. The head and foot are removed in this section and prepared for transferring to the processing section.

PROCESSING CONVEYOR

Sheep's skin, internal organs and offal are removed on thi automatic conveyor. Carcasses are prepared for resting and loading. Carcasses are hung to the multiple hooked special sheep trolley at the end of the processing line and transferred to the cold rooms and loading point.

BUTCHER WORKING PLATFORM

These fixed working platforms are designed for butchers to provide comfortable and efficient working environment. All platforms have basins and knife sterilization units on it.

SHEEP DEHIDER

The sheep dehiding machine operates in a manner touching the meat and skin at the minimum level and reduces the damage. It is ideal for the sheep and goat. The sheep dehiding machine consist of parts movable from the top to the bottom. With the help of a chain fixed to the skin, the drum is wrapped downwards and the skin is separated from the carcass in a short time.

MEAT LOWERING ELEVATOR

This elevator is used for lowering carcasses from high line.



KOYUN SABİTLEME ÜNİTESİ

Paslanmaz çelikten imalatı yapılır. Ayarlanabilir genişliği sayesinde, hemen hemen her cins küçükbaş için kullanılabilir. Küçükbaş hayvan sabitleme makinasına girdikten sonra hareketli konveyör sayesinde makinanın en üst bölümüne gelir. Kasap tarafından kesim işlemi gerçekleştirilmesinin ardından koyun kanama tavasına düşürülür.

KOYUN KALDIRMA ELEVATÖRÜ

Küçükbaş hayvanın kesim işleminden son-ra kanama konveyörüne alınması sağlayan otomatik sistemdir.

KANAMA KONVEYÖRÜ

Küçükbaş hayvanın kesim işlemi gerçekleştirildikten sonra kanama işleminin yapıldığı otomatik konveyör-dür. Bu bölümde kelle alınır ve ayaklar açılıp kesilerek işleme hattı transferine uygun hale getirilir.

İŞLEME KONVEYÖRÜ

Küçükbaş karkası deri, iç organ ve sakadatından ayırma işleminin yapıldığı otomatik hattır. Bu bölümde küçükbaş karkas dinlendirmeye ve sevkiyata hazır hale getirilir. İşleme konveyörünün bitiminde kapasiteye göre karkaslar çoklu kancalı arabalara aktarılır.

KASAP ÇALIŞMA PLATFORMU

Kasapların hat üzerinde rahat ve verimli çalışmalarına olanak verecek biçimde tasarlanmış sabit platformlardır. İç organ alma, sakatat çıkarma ve hatlar arası transfer işlemlerini ger-çekleştirmek için kullanır. Platform üzerinde lavabo ve bıçak sterilize üniteleri mevcuttur.

KOYUN DERİ YÜZME İSTASYONU

Deri yüzme makinası, hareketli tamburu sayesinde ete zarar vermeden koyun derisinin yüzülmesini sağlar. Hareketli tambur, deriye takılan zincir ile kısa sürede derinin yukarıdan aşağıya yüzülmesini sağlar.

ET İNDİRME ELEVATÖRÜ

Karkas etin yüksek hattan indirilmesini sağlayan otomatik sistemdir.



**SHEEP ELEVATOR
KOYUN KALDIRMA ELEVATÖRÜ**

Transfer to the Monorail line of 45°
1.5 kW Gear Motor
Material: Galvanized

45° Monoray hattına transfer
1.5 kW Dişli Motor
Malzeme: Galvanizli



**BLEEDING LINE
KANAMA HATTI**

2x30x50 mm Stainless
Material: Galvanized Body
NPI-NPU profile chassis and carriers

2x30x50 mm Paslanmaz
Malzeme: Galvanizli Gövde
NPI-NPU profil ve taşıyıcılar



**SKIN DEHIDER MACHINE
DERİ YÜZME MAKİNESİ**

Capacity: 40 Skinning Per Hour
System: Hydraulic
Stainless & Galvanized

Kapasite: Saatte 40 Deri Soyma
Sistem: Hidrolik
Paslanmaz ve Galvanizli



**SHEEP FIXING UNIT
KOYUN SABİTLEME MAKİNESİ**

Between Drum Axes: 3040 mm
1.1 kW geared motor
Band Quantity: 2 Pieces

Tambur Eksenleri Arası: 3040 mm
1.1 kW dişli motor
Bant Miktarı: 2 Adet



**BUTCHER PLATFORMS
KAŞAP PLATFORMLARI**

Platform chassis 40X40 mm
Size 1200 *2000 *600 mm
Material: Stainless-Galvanized

Platform şasi 40X40 mm
Boyut 1200 * 2000 * 600 mm
Malzeme: Paslanmaz-Galvanizli

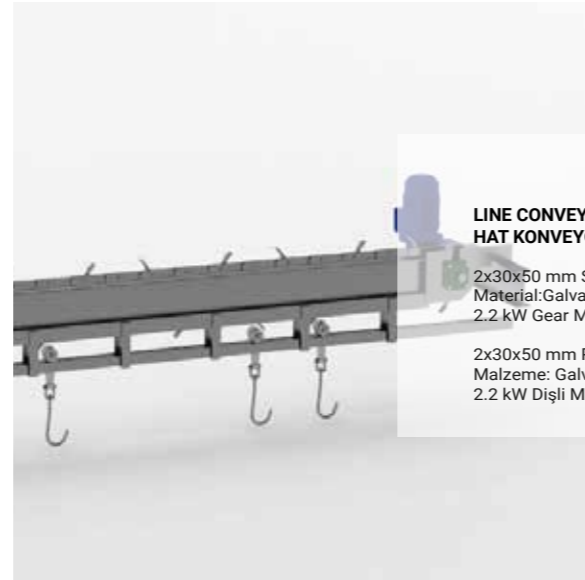

**LINE CONVEYOR
HAT KONVEYÖRÜ**

2x30x50 mm Stainless
Material: Galvanized Body
2.2 kW Gear Motor

2x30x50 mm Paslanmaz
Malzeme: Galvanizli Gövde
2.2 kW Dişli Motor



**SHOWER CABIN
DUŞLAMA KABİNİ**

Sprinkler system with stainless
nozzle
Stainless steel
Ø 1/2 pipe shower system

Paslanmaz nozullu
Paslanmaz çelik
Ø 1/2 borulu duş sistemi



**BLEEDING PAN
KANAMA TAVASI**

AISI 304 Stainless (20*25*2 mm)
Material: Stainless
Two outputs

AISI 304 Paslanmaz (20*25*2 mm)
Malzeme: Paslanmaz
iki çıkış

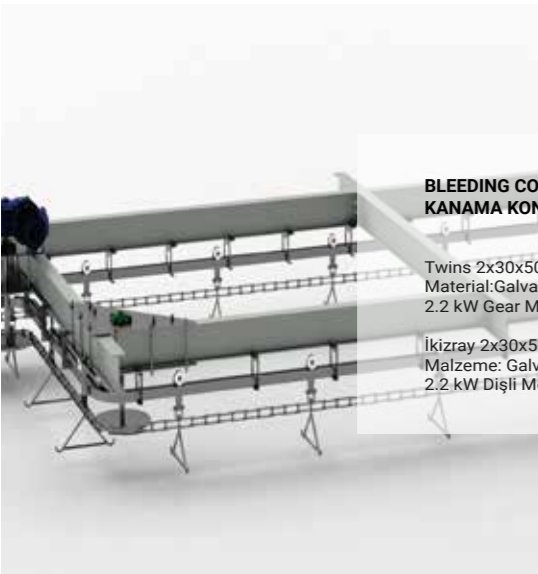

**BLEEDING CONVEYOR
KANAMA KONVEYÖRÜ**

Twins 2x30x50 mm Stainless
Material: Galvanized Body
2.2 kW Gear Motor

İkizray 2x30x50 mm Paslanmaz
Malzeme: Galvanizli Gövde
2.2 kW Dişli Motor



**SHEEP HANGER
KOYUN ASMA ARABASI**

Capacity : 600-800 Kg
Twins Hook Up 6s - 8s
Stainless Steel

Kapasite : 600-800 Kg
İkizler 6'lı - 8'li Kanca
Paslanmaz çelik



**BAND CONVEYOR
BANT KONVEYÖRÜ**

Material: Stainless
1.1 kW Gear Motor
System : Modular Tape

Malzeme: Paslanmaz
1.1 kW Dişli Motor
Sistem : Modüler Bant



**BLEEDING PULLEY
KANAMA MAKARASI**

Material: Stainless-Galvanized

Malzeme: Paslanmaz-Galvanizli



OFFAL CLEANING EQUIPMENTS

Sakatat Temizleme Makineleri

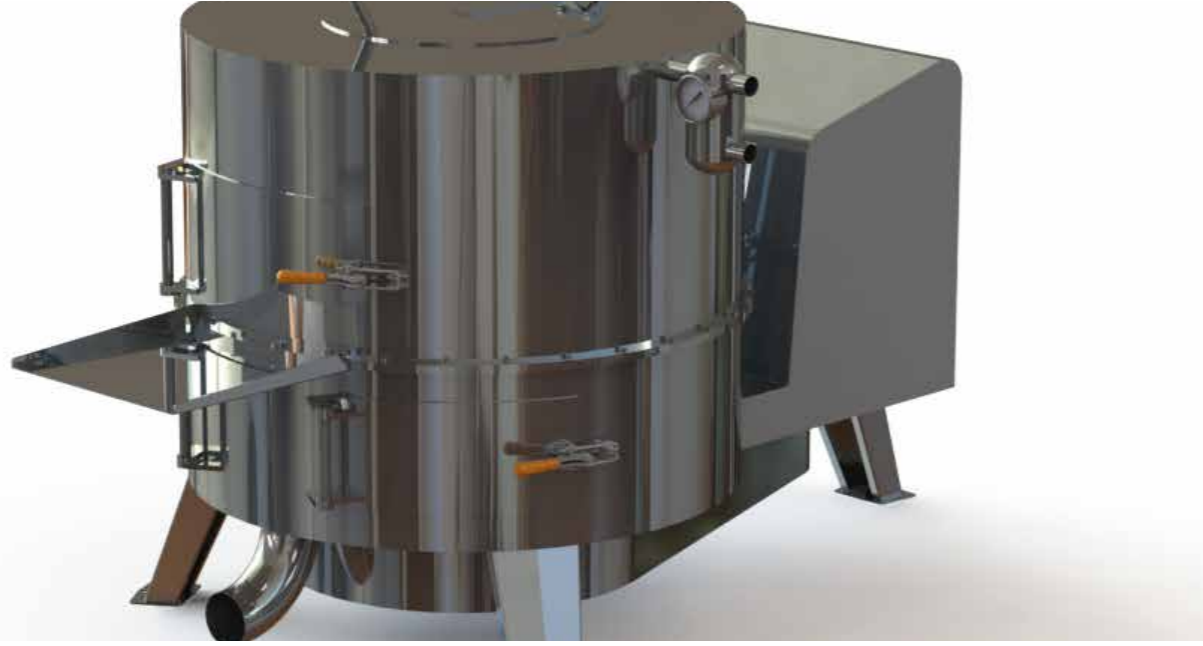

TRIPLE CLEANING MACHINE İŞKEMBE TEMİZLEME MAKİNESİ

7.5 Tons of tripe in 10 hours
Cleaning time 10 minutes
Cleaning : 100%
Cleaning Temperature: 70 C°
7.5-11 KW double speed motor
Machine dimensions: 120 * 100 * 200 cm
Weight:550 kg
polyester board

10 saatte 7.5 Ton işkembe
Temizleme süresi 10 dakika
Temizleme : %100
Temizleme Sıcaklığı:70 C°
7.5-11 KW çift devirli motor
Makine ölçüleri:120*100*200 cm
Ağırlık:550 kg
polyester pano

CATTLE FEET CLEANING MACHINE DANA PAÇA TEMİZLEME MAKİNESİ



Cleaning time: 20 minutes
Cleaning rate: 95%
Cleaning Temperature: 50-60 C°
Fully automatic polyester board
Engine: 7.5 - 11 KW, 750 - 1500 rpm
Height: 120 cm
Width: 125 cm
Length: 180 cm

Temizleme süresi:20 dakika
Temizleme oranı:%95
Temizleme Sıcaklığı: 50-60 C°
Tam otomatik polyester pano
Motor: 7.5 - 11 KW , 750- 1500 devir / dakika
Makine ölçüleri : Yükseklik :120 cm
Genişlik:125 cm
Uzunluk:180 cm



OMASUM CLEANING MACHINE
KIRKBAYIR TEMİZLEME MAKİNESİ



BOWEL CLEANING MACHINE
BAĞIRSAK TEMİZLEME MAKİNESİ



HOOF REMOVAL MACHINE
TIRNAK SÖKME MAKİNESİ



STORAGE BOILER
DEPOLAMA KAZANI

OFFAL CLEANING EQUIPMENTS

QURBAN SLAUGHTERING CENTER PROJECT

KURBAN KESIM MERKEZİ

Teknotes manufactures all the equipment needed for a slaughterhouse from paddock to slaughtering box, to slaughtering lines equipment and processing units



QURBAN SLAUGHTERING KURBAN KESIMHANESI

Features Qurban Slaughtering Center;
Provides 300 caattles slaughtering capacity per day,
Complies with international hygiene rules and standards,
Provides healthy, safe and clean slaughtering environment,
Prevents public slaughtering on the streets and keeps streets clean,
Provides much more controllable environment for slaughtering.

Günlük 300 büyükbaş kesim kapasitesi,
Uluslararası standartlarda hijyen kurallarına uyumluluk,
Sağlıklı, güvenli ve temiz bir ortamda kesim olanağı,
Şehirlerde mahalle ve sokak üzerinde kesim ihtiyacını ortadan kaldırır,
Kesimlerin kontrol altında yapılmasını sağlar,
Kontrolsüz kesimden kaynaklı çevre kirliliklerini ve olası hastalık tehditlerini önler.



Qurban Slaughtering Center Project is designed for easy, healthy and clean slaughtering for the public. It's designed to slaughter 300 cattle per day, but can be increased by some minor modifications depending on our customer's requests. Project design consists of parking lot, cafeteria, slaughtering hall, administration office, mosque, sales office and everything that needed.

Kurban Bayramlarında halka hizmet vermek üzere tasarlanmış Kurban Kesim Merkezi projemiz ile daha sağlıklı, güvenli, temiz ve kontrol edilebilir ortamlarda kesim olanağı sunmaktayız. Günlük 300 adet büyükbaş kesim kapasitesine sahip Kurban Kesim Merkezimiz otoparktan kafeteryaya, yönetim binasından Mescide ve satış yerine kadar vatandaşlarımızın ihtiyaç duyacağı herşey düşünülerek projelendirilmiştir.



INSTALLATION AND CONTRACTING



TEKNOTES designs authentic projects providing you with the most ergonomic, efficient and affordable solutions based on your needs and capacity demand for the slaughterhouse equipment to be used in your facility.

Contracting services are provided in a fast, flawless way and tailored to your needs through excellent integrated projects in which all the necessary details are considered.

The fact that manufacturing, project designing and project implementation are solved all from a single point saves you time, bringing down the cost.

Through architectural project designing, areas such as administrative units, dining halls, showers, toilets, manufacturing yards, storehouses, entry and exit points for products are identified.

Through static project designing, ultimate load capacity of concrete- steel based on the capacity of buildings and ground-subsurface studies, bearing capacity, floor and roof plans, framework system are calculated thoroughly.

Through electrical installation projects, designed for license and implementation, projects complying with regulations are designed. Installation drawing includes the elements such as lighting, transformer, medium voltage, plug socket, fire warning, security systems, fire warning alarm, computers and data infrastructure.

Through mechanical project designing, heating, cooling, ventilating, clean and contaminated water, drainage, sanitary hot water pipes and fire extinguishing systems are thoroughly identified. Through ventilating and cooling project designing, all ventilating and cooling systems are planned based on the characteristics and capacity of the facility.



CONSTRUCTION OF SLAUGHTER MEZBAHA BINA İNŞAATI

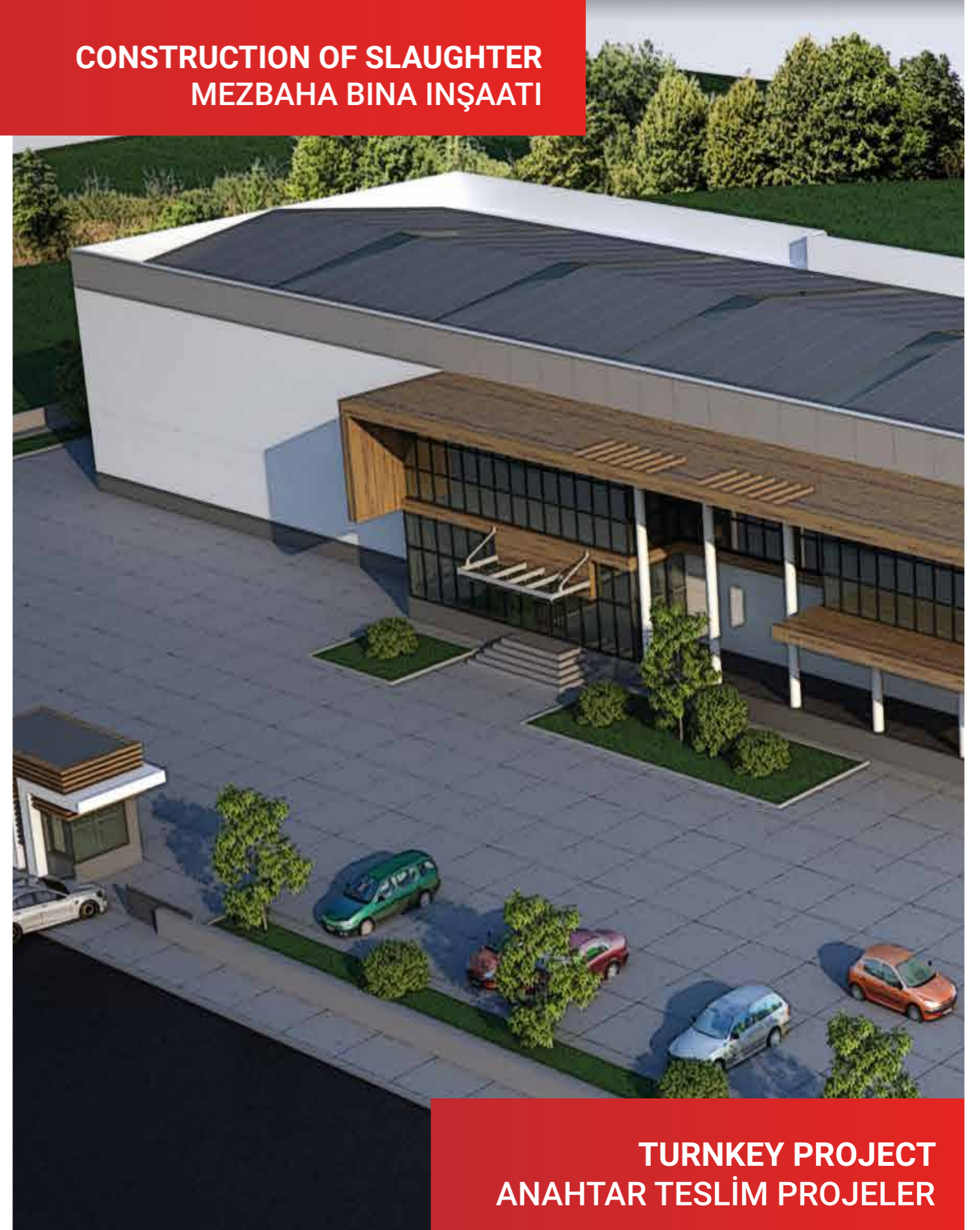

**TURNKEY PROJECT
ANAHTAR TESLİM PROJELER**

COOLING SYSTEMS COLD STORAGE

SOĞUTMA SİSTEMLERİ SOĞUK ODA

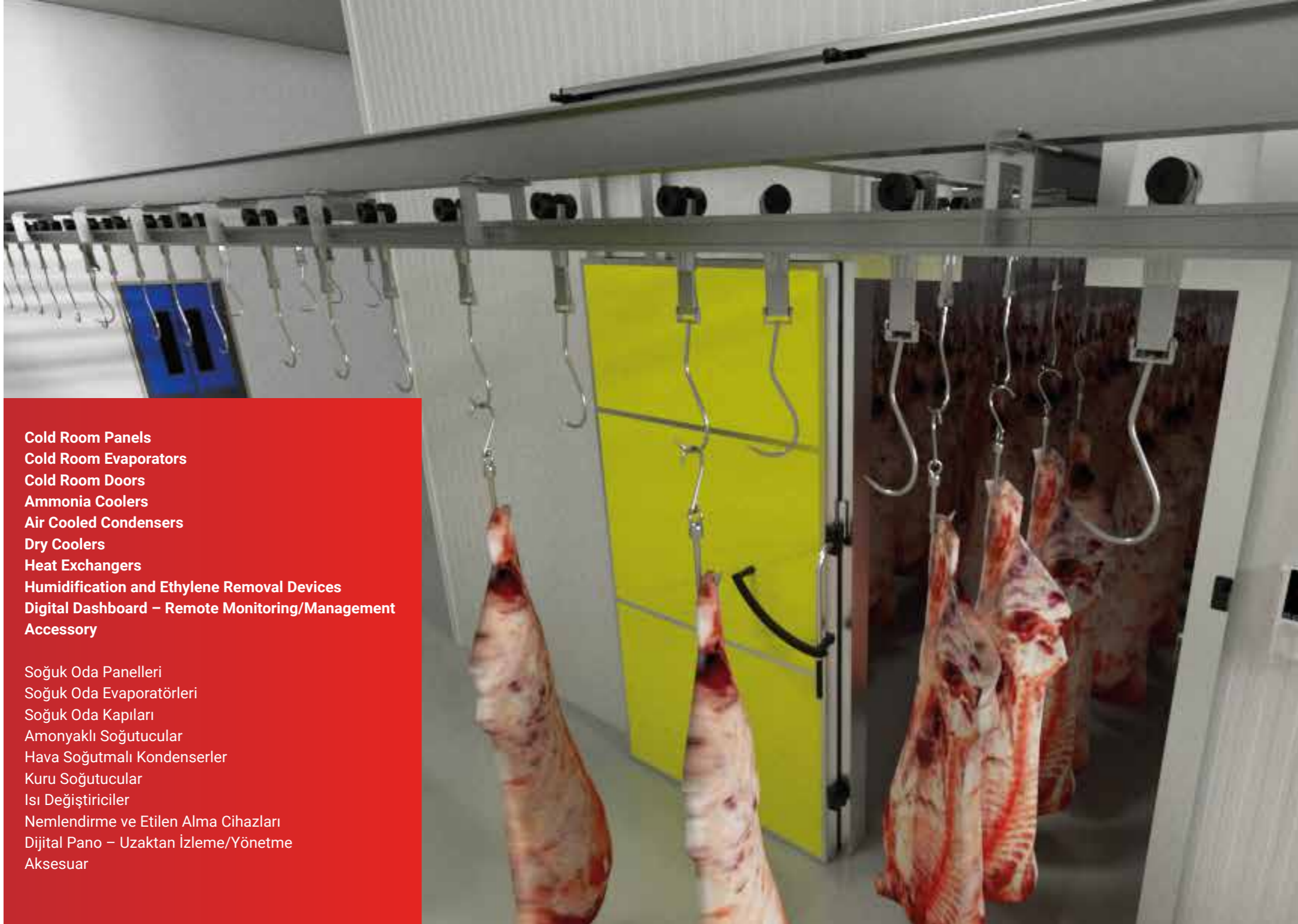

Cold Room Panels
Cold Room Evaporators
Cold Room Doors
Ammonia Coolers
Air Cooled Condensers
Dry Coolers
Heat Exchangers
Humidification and Ethylene Removal Devices
Digital Dashboard – Remote Monitoring/Management
Accessory

Soğuk Oda Panelleri
Soğuk Oda Evaporatörleri
Soğuk Oda Kapıları
Amonyaklı Soğutucular
Hava Soğutmalı Kondenserler
Kuru Soğutucular
Isı Değiştiriciler
Nemlendirme ve Etilen Alma Cihazları
Dijital Pano – Uzaktan İzleme/Yönetme
Aksesuar

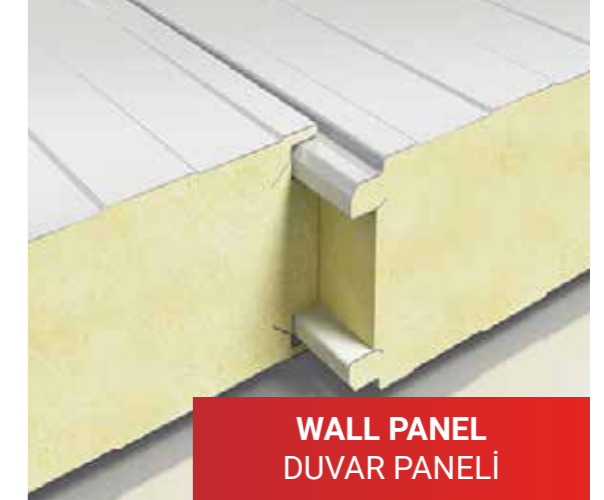

WALL PANEL
DUVAR PANELİ

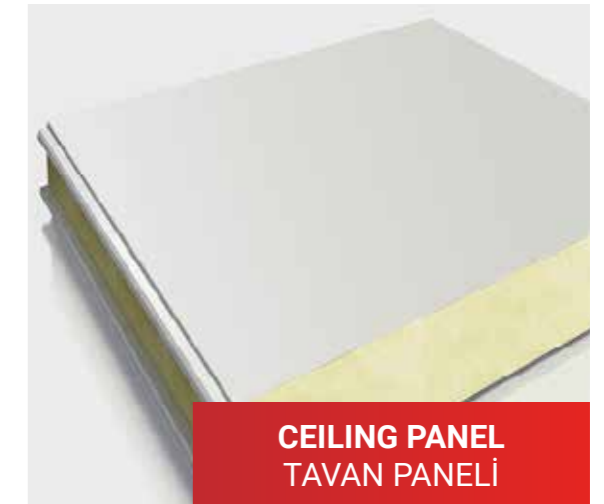

CEILING PANEL
TAVAN PANELİ



FLOOR PANEL
ZEMİN PANELİ

COLDROOM DOORS

SOĞUKODA KAPILARI

Reliable & technological cold room doors
Güvenilir & teknolojik soğuk oda kapıları

SLIDING COLD ROOM DOOR

CTP composite construction
1,5 mm AMB (antimicrobial) CTP,
painted sheet or stainless surface
EPDM rubber based sealing system Stainless
surface with 1,5 mm AMB
(antimicrobial) CTP
Anodised aluminium that prevents heat transfer
for the door frame and blade
Door blade : 42 kg/m³ density high
pressure polyurethane injection
220 volt, 25 w/m silicone based
resistance on frozen storage doors Aluminium
profile with resistance on the floor.

SÜRGÜLÜ SOĞUKODA KAPISI

CTP kompozit konstrüksiyon
1,5 mm AMB (antimikrobiyel) CTP, boyalı
sac veya paslanmaz yüzey
EPDM kauçuk esaslı conta sistemi
1,5 mm AMB (antimikrobiyel) CTP
kullanımında eksiz yüzey
engelleyen eloksallı alüminyum
Kapı kanadı, 42 kg/m³ yoğunlukta
yüksek basınç poliüretan injeksiyon
Donmuş muhafaza kapılarında 220 volt
25 w/m silikon esaslı rezistans
Zeminde rezistanslı alüminyum profil



EXCELLENT LIQUIDITY
PROPERTIES WITH RUBBER
BASED GASKET SYSTEM

KAUÇUK ESASLI CONTA
SİSTEMİ İLE MÜKEMMEL
SIZDIRMAZLIK ÖZELLİĞİ



COLDROOM DOORS

MONORAIL SLIDING COLD ROOM DOOR MONORAY SÜRGÜLÜ SOĞUKODA KAPISI

CTP composite material
1,5 mm AMB (antimicrobial) CTP, painted sheet or stainless surface – EPDM rubber system
Desired color choice in door blade
Anodised aluminium that prevents heat transfer for the door frame and blade
Door blade : 42 kg/m³ density high pressure polyurethane injection – Monorail system on door and frame
Polyamid protecting door blade in articulated system

CTP kompozit konstrüksiyon
1,5 mm AMB (antimikrobiyel) CTP, boyalı sac veya paslanmaz yüzey
EPDM kauçuk esaslı conta sistemi
1,5 mm AMB (antimikrobiyel) CTP kullanımında eksiz yüzey
Kapı kanadında istenilen renk seçeneği
Kapı kanadı ve kasası, ısı transferini engelleyen eloksallı alüminyum
Kapı kanadı, 42 kg/m³ yoğunlukta yüksek basınç poliüretan injeksiyon – Mafsallı ve sabit monoraylı sistem uygunluğu
Mafsallı sistemde kapı kanadını koruyan poliamid parça
Sabit monoraylı sisteme uygun paslanmaz yüzeyi profilleri



HINGED COLD ROOM DOORS MENTEŞELİ SOĞUK ODA KAPILARI

Anodised aluminium that prevents heat transfer for the door frame and blade
Door blade : 42 kg/m³ density high pressure polyurethane injection
1,5 mm AMB (antimicrobial) CTP, painted sheet or stainless surface
Desired color choice in door blade
Door lock that can be opened from inside (evenlocked) and outside
Rising and adjustable hinges
EPDM rubber system
220 volt, 25 w/m silicone based resistors on frozen storage doors

Kapı kanadı ve kasası, ısı transferini engelleyen eloksallı alüminyum
Kapı kanadı, 42 kg/m³ yoğunlukta yüksek basınç poliüretan injeksiyon
1,5 mm AMB (antimikrobiyel) CTP, boyalı sac veya paslanmaz yüzey
Kapı kanadında istenilen renk seçeneği – İçerden ve dışarıdan açılabilir kapı kilidi – Yükselen tip menteşe
EPDM kauçuk esaslı conta sistemi
Donmuş muhafaza kapılarında 220 volt 4 25 w/m silikon esaslı rezistans



SOĞUKODA KAPILARI



DOUBLE WING HINGED DOOR WITH MONORAY PASSAGE ÇİFT KANAT MONORAYLI MENTEŞELİ SOĞUK ODA KAPILARI

Anodised aluminium that prevents heat transfer for the door frame and blade
Door blade 42 kg/m³ density high pressure polyurethane injection
1,5 mm AMB (Antimicrobial) CTP, painted sheet or stainless surface

Kapı kanadı ve kasası, ısı transferini engelleyen eloksallı alüminyum
Kapı kanadı, 42 kg/m³ yoğunlukta yüksek basınç poliüretan injeksiyon
1,5 mm AMB (Antimikrobiyel) CTP, boyalı sac veya paslanmaz yüzey

Anodised aluminium that prevents heat transfer for the door frame and blade
Door blade: 42 kg/m³ density high pressure polyurethane injection
1,5 mm AMB (antimicrobial) CTP, painted sheet or stainless surface
Desired color choice in door blade
EPDM rubber sealing system suitable for blade profile
Hinges that can be opened in and out, fixed at 90° if necessary
Impact absorbent pvc protective band

Kapı kanadı ve kasası, eloksallı alüminyum
Kapı kanadı, 42 kg/m³ yoğunlukta yüksek basınç poliüretan injeksiyon
1,5 mm AMB (antimikrobiyel) CTP, boyalı sac veya paslanmaz yüzey
Kapı kanadında istenilen renk seçeneği
Yükselen tip menteşe
Kanat profiline uygun EPDM kauçuk esaslı conta sistemi
EPDM kauçuk contalı pleksiglas kapı kanadı camları
İçeri dışarı açılabilen gerektiğinde 90° de sabitlenen menteşeli
Darbe emici PVC koruma bandı

FLIP-FLOP DOOR FLIP-FLOP KAPI



Reliable & technological cold room doors
Güvenilir & teknolojik soğuk oda kapıları



HERMETIC SPLIT TYPE COOLING UNIT HERMETİK SPLIT TYPE SOĞUTMA ÜNİTESİ

Split Type Hermetic Capacitor Units are suitable for cold rooms and reion cooling with low capacity requirements. Small Compact design makes it easy to assemble and maintain. The Sound pressure values are at a minimum level.

Split Tipi Hermetik Kondanser Üniteleri düşük kapasite ihtiyaçlarının olduğu soğuk odalar ve reyon soğutmalarına uygundur. Küçük kompakt tasarımı sayesinde montajı ve bakımı kolaydır. Ses basınç değerleri minimum seviyededir.



SCROLL SPLIT TYPE COOLING UNIT SCROLL SPLIT TYPE SOĞUTMA ÜNİTESİ

In Split Type Scroll Capacer Units, the sound and vibration are at a low level. in Particular, it is perfectly suited to grocery and supermarket applications. Energy consumption is minimal with energy efficiency applications.

Split Tipi Scroll Kondanser Üniteleri'nde ses ve titreşim düşük seviyededir. Özellikle market ve süpermarket uygulamalarına mükemmel uygunluktur. Enerji verimlilik uygulamalarıyla enerji tüketimi minimum seviyededir.



SEMI HERMETIC SPLIT TYPE COOLING UNIT SEMİ HERMETİK SPLIT TYPE SOĞUTMA ÜNİTESİ

SplitType Semi-Hermetic Condenser Units are suitable for low to medium capacity cooling needs. it offers wide selection options thanks to its Large capacity ranges. Long-lasting and trouble-free thanks to proven high quality compressors.

Split Tipi Semi Hermetik Kondanser Üniteleri düşük ve orta kapasitedeki soğutma ihtiyaçları için uygundur. Geniş kapasite aralıkları sayesinde geniş seçim seçeneği sunmaktadır. Kendini ispatlamış kaliteli kompresörler sayesinde uzun ömürlü sorunsuzdur.

IP55 Integrated Electrical Panel
Easy Maintenance
Quality Equipment
Compatible condensers far hat environment
Complete, Ready far Installation Compact Design
Non-vibration operation
Electrical Panels Compatible to the Standards
Quick Easy Setup
Ultra Quiet Fan Option



IPSS Entegre Elektrik Panosu
Kolay Bakım
Kaliteli Ekipmanlar
Yüksek Sıcaklara Uygun Kondanser
Komple, Kurulumu Hazır KompaktTasarım
Titreşimsiz Çalışma
Standartlara Uygun Elektrik Panosu
Hızlı Kolay Kurulum
Ultra Sessiz Fan Seçeneği

BÜYÜKBAŞ AHIR ÇİFTLİĞİ

PRODUCTS / ÜRÜNLER



FERTILIZER SEPARATOR
600 MICRON
GÜBRE SEPERATÖRÜ
600 MICRON



FERTILIZER PUMP 7.5 KW
GÜBRE POMPASI 7.5 KW



FERTILIZER MIXER 15 KW
GÜBRE KARIŞTIRMA
MAKİNASI 15 KW

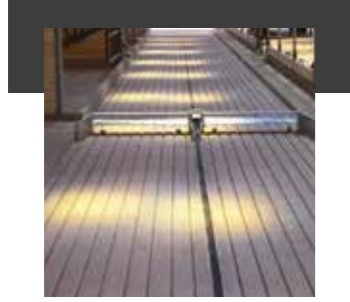

AUTOMATIC CHAIN FERTILIZER
SCRAPER SYSTEM
OTOMATİK ZİNCİRLİ GÜBRE
SİYİRİCİ SİSTEMİ

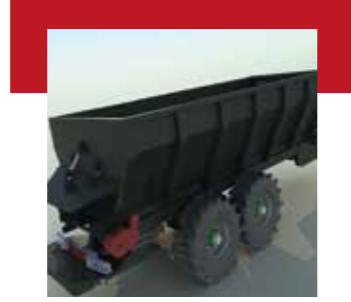

SOLID FERTILIZER DISTRI-
BUTION TRAILER 15 M3
KATI GÜBRE DAĞITMA
RÖMORKU 15 M3



LIQUID FERTILIZER TRANS-
PORT AND DISTRIBUTION
14 TON
SIVI GÜBRE TAŞIMA VE
DAĞITMA 14 TON



DRINKER ANIMAL DRAINER
WITH STAINLESS TIPPING
BÜYÜKBAŞ HAYVAN
SULUĞU PASLANMAZ
DEVİRMELİ



AUTOMATIC ANIMAL BRUSH
OTOMATİK HAYVAN FIRÇASI



ANIMAL SCALE
HAYVAN KANTARI

CATTLE BREEDING FARM

Turnkey System

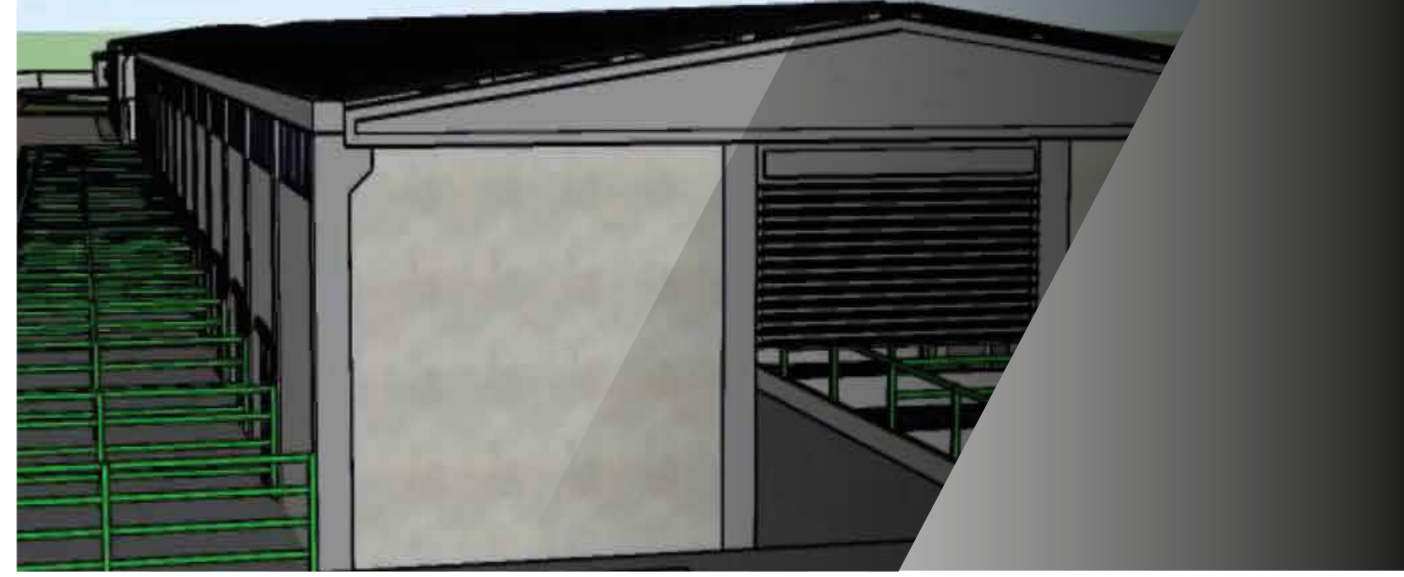

THINK GLOBAL WORLDWIDE



REFERENCES TEKNOTES TASARIM

TRUST TRADE LIMITED CO . (MONGOLIA)
Shoqata Bëmirëse Jetimat e Ballkanit (KOSOV)
Azteserrufat Limited Liability Company (AZERBAIJAN)
Rizvan-EI MMC - ye (AZERBAIJAN)
Qoç Et (AZERBAIJAN)
C.V Awal Putra Ma Rangga (INDONESIA)
Meat Processing And Service (KAZAKHSTAN)
Agrozoomed SRL (ROMANIA)
Kaindy LLC QUAINDY (KAZAKHSTAN)
Abdrassilov Farm (KAZAKHSTAN)
Eastern Kitchen Supplies Limited (QATAR)
Caritas Czech Republic in Georgia
BEYPINAR MEZBAHASI (TURKEY)
Polatlı Et Kombinası (CAPITAL OF TURKEY)
Erzincan Belediyesi Et Entegre Tesisi (TURKEY)
Antalya Sherwood Resorts and Hotel (TURKEY)
Bilecik Belediye Mezbahası (TURKEY)
Güler Et ve Et Ürünleri (TURKEY)
Atılğan Et (TURKEY)
Giresun Tirebolu Mezbahası (TURKEY)
Afyon Çay Belediye Mezbahası (TURKEY)
Mühsüroğlu Et Entegre Tesisleri (TURKEY)
Etaş Et Ürünleri A.Ş (TURKEY)
Antalya Elmalı Belediye Mezbahası (TURKEY)
Niğde Açık Cezaevi Et Entegre (TURKEY)
İSM Et Silivri (TURKEY)
Önder Et (TURKEY)

Giresun Görele Belediye Mezbahası (TURKEY)
Araz Et Gıda (TURKEY)
İmtaş Besi Çiftliği (TURKEY)
Bakanlar Et Kombinası (TURKEY)
Nefis Et Gıda (TURKEY)
Konya Arvası Mezbahası (TURKEY)
Yüksel Et Gıda (TURKEY)
Günbeyi Et Gıda (TURKEY)
Kemberburgaz Sütçü Yusuf Besi Çiftliği (TURKEY)
Düzgün Marketçilik Gıda (TURKEY)
Lokmangil Besi Çiftliği (TURKEY)
Çetin Et (ŞİLE , TURKEY)
MERT KARDEŞLER BESİ ÇİFTLİĞİ (TURKEY)
Güven Besicilik (TURKEY)
Polkara Gıda (TURKEY)
Zafer Sucukları Et Entegre Tesisi (TURKEY)
Narman Açık Ceza İnfaz Kurumu (TURKEY)
Çorum Kargı Belediye Mezbahası (TURKEY)
Kars Açık Ceza İnfaz Kurumu (TURKEY)
Cihan Besicilik (TURKEY)
ÖzKarakuş Besi Çiftliği (TURKEY)
Sahra Besi Çiftliği (TURKEY)
SPK Sucukları (TURKEY)
Antalya Gazipaşa Belediye Mezbahası (TURKEY)
Antalya Kumluca Belediye Mezbahası (TURKEY)
Sinop Belediye Mezbahası (TURKEY)

”

DESIGN YOUR OWN
SLAUGHTERHOUSE PLAN
LET'S MAKE IT BUILD
REALITY TOGETHER.



Ministry of Justice TURKEY

-KARS AÇIKCEZA İNFAZ KURUMU
-NİĞDE AÇIK CEZA İNFAZ KURUMU

Meat
Technologies
Et Teknolojileri

TEKNOTES TASARIM MAKİNE SANAYİ VE TİCARET LİMİTED ŞİRKETİ
TEKNOTES GROUP İNŞAAT İTHALAT İHRACAT VE ANONİM ŞİRKETİ

TÜRKİYE / TURKEY
İMALATÇI - MANUFACTURER
www.mezbaha.com

HIGHLIGHT

TEKNOTES TASARIM

supplies the most modern slaughter and integrated meat processing facilities with paddock, slaughter, meat processing, storage, refrigerator rooms and carriage systems for cattle, camel and sheep. We give importance to hygiene, ergonomics, safety, quality, animal health and butcher health at our company.



+90 555 893 98 01
+90 546 844 09 04



bilgi@mezbaha.com
www.mezbaha.com