

NOTE: THIS IMAGE MERELY REPRESENTS THE BUILDING TYPE SUGGESTED,
THIS BUILDING WAS NOT BUILT WITH CLIMATE-DECK™ TILT-UP ROOF



CLIMATE-DECK™ TILT-UP ROOF THIS SYSTEM IS DESIGNED TO SPAN 50' BAYS

THESE DOCUMENTS ARE FOR REFERENCE ONLY
CONSULT YOUR LOCAL STRUCTURAL & SHORING ENGINEERS
FOR SPECIFICATIONS.



CLIMATE-DECK™
TILT-UP FORMS
50' SPAN DESIGN

(4.2) @ 24" x 48" x 144"

TILT-UP ROOF DESIGN

Project number	CD2448144TU	100-CS
Date	06.12.2023	
Drawn by	ALMA JESSOP	Scale
Checked by	AJ	

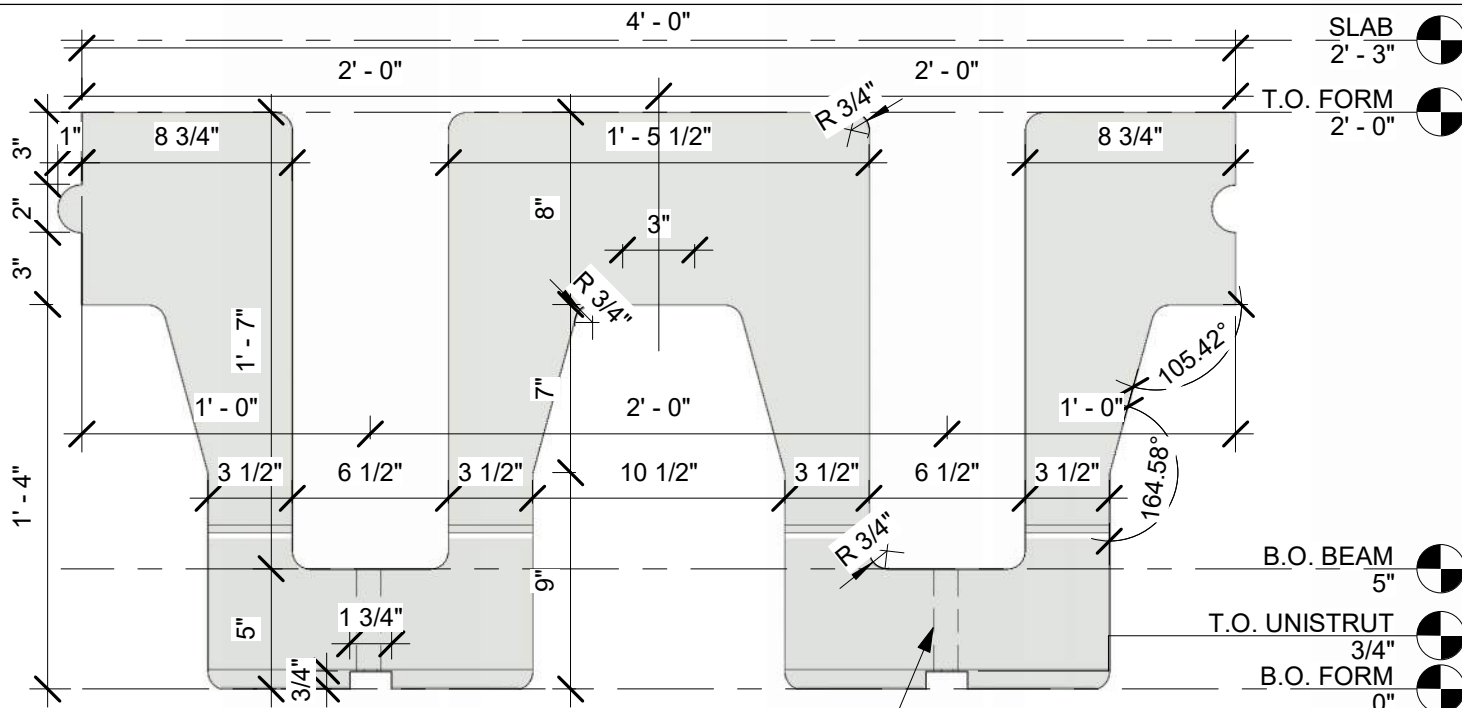

1 FRONT ELEV
1 1/2" = 1'-0"

DECK #1

VERTICAL HOLES
DRILLED BY OTHERS

DECK #2 etc.



2 RIGHT ELEV
1/4" = 1'-0"

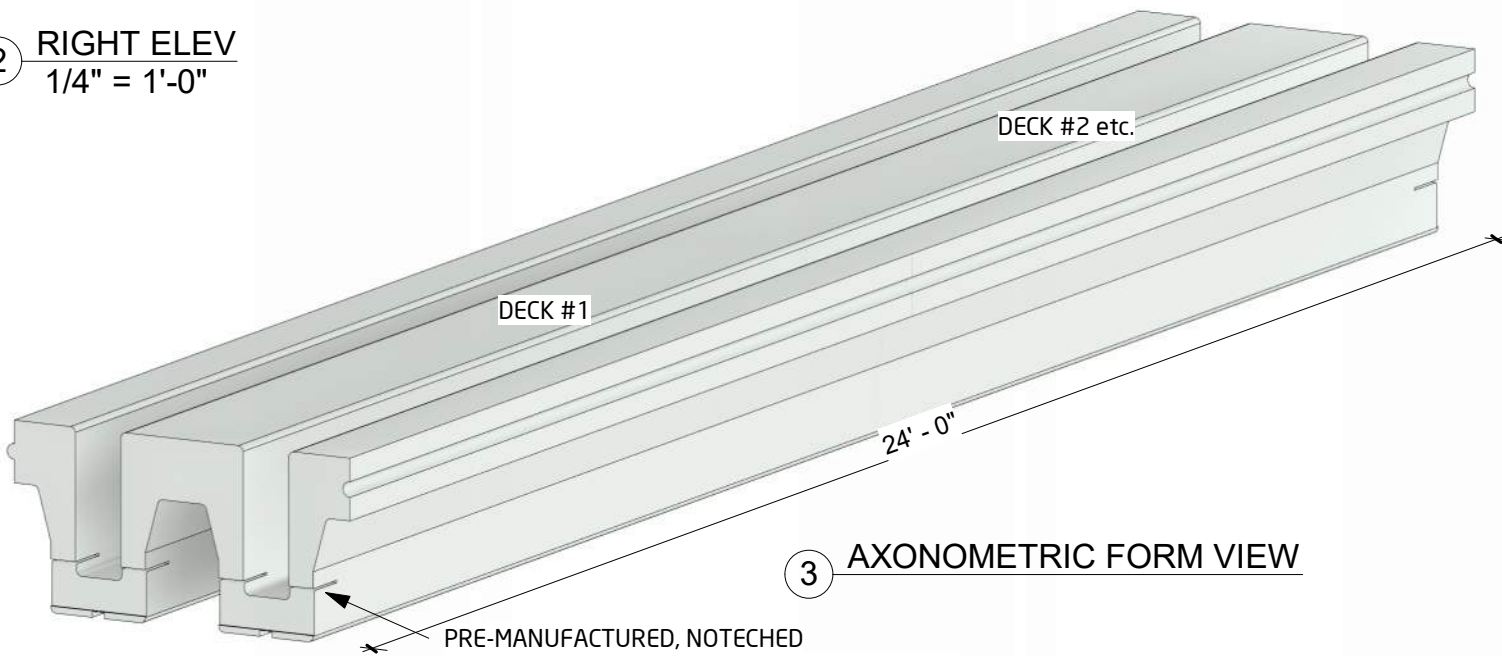

3 AXONOMETRIC FORM VIEW

PRE-MANUFACTURED, NOTCHED
FORM FOR 6x6 ANGLE IRON PROFILE, IF NEEDED



CLIMATE-DECK™
TILT-UP FORMS
50' SPAN DESIGN

(4.2) @ 24" x 48" x 144"

FORM PROFILE

Project number	CD1848144	D1.0
Date	06.12.2023	
Drawn by	ALMA JESSOP	
Checked by	AJ	
Scale		As indicated

T.O. SLAB
2' - 3"

T.O. FORM
2' - 0"

PRE NOTCHED FORM
W/6X6 ANGLE IRON
PROFILE

REBAR CHAIR

B.O. BEAM
5"

T.O. UNISTRUT
3/4"

B.O. FORM
0"

VERTICAL TIES
SLOT OPENING FOR
LOCKING PIN WEDGE

VERTICAL TIE ANCHORS
CEILING MEMBER TO
CONCRETE BEAM & REBAR CHAIR WITH
LOCKING PIN WEDGE

CEILING MEMBER

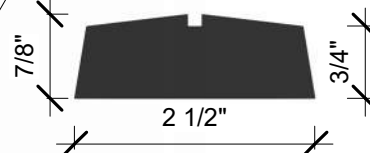

1 VERTICAL TIE CROSS SECTIONS

1 1/2" = 1'-0"

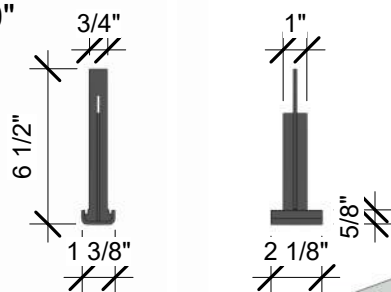

4 LOCKING PIN WEDGE

6" = 1'-0"

2 VERTICAL TIE ELEV

1 1/2" = 1'-0"

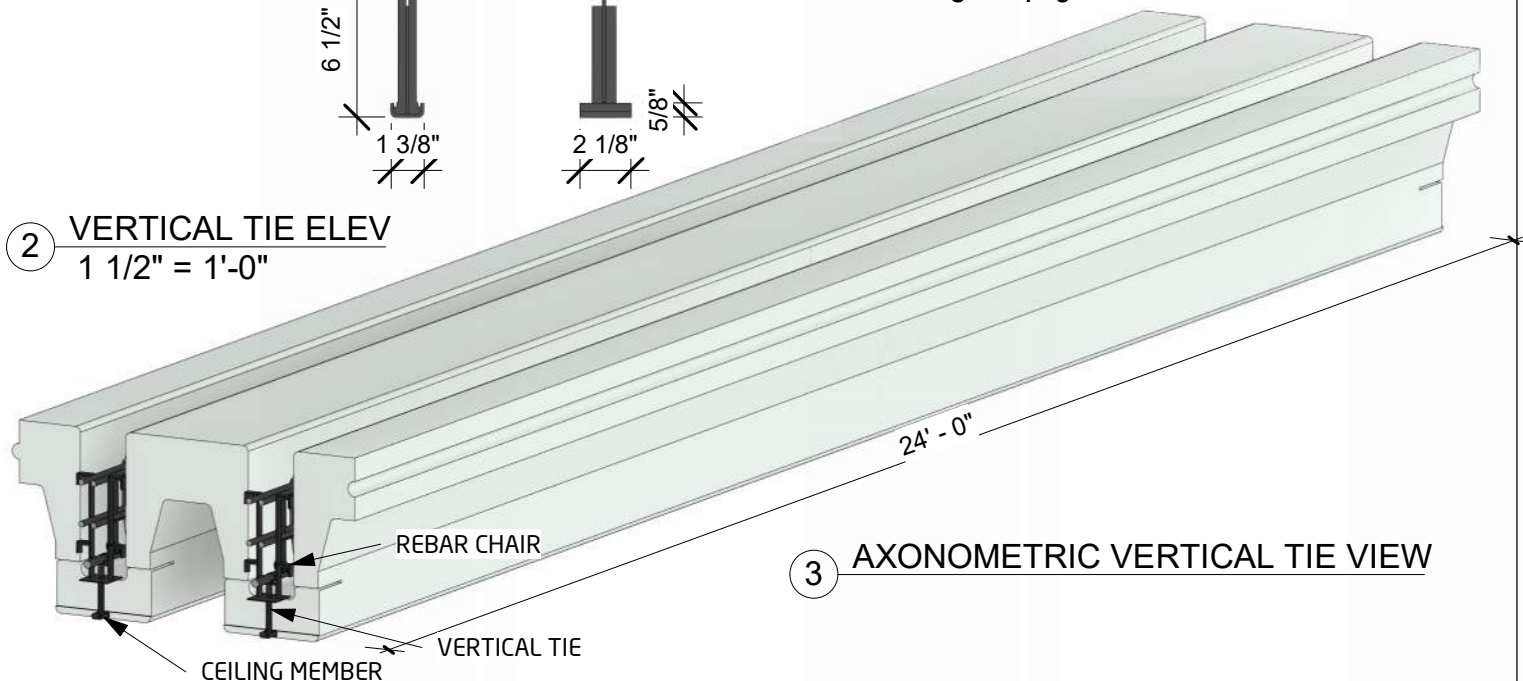

3 AXONOMETRIC VERTICAL TIE VIEW



CLIMATE-DECK™
TILT-UP FORMS
50' SPAN DESIGN

(4.2) @ 24" x 48" x 144"

TIE to CHAIR CONNECTION

Project number CD1848144

Date 06.12.2023

Drawn by ALMA JESSOP

Checked by AJ

D3.0

Scale As indicated

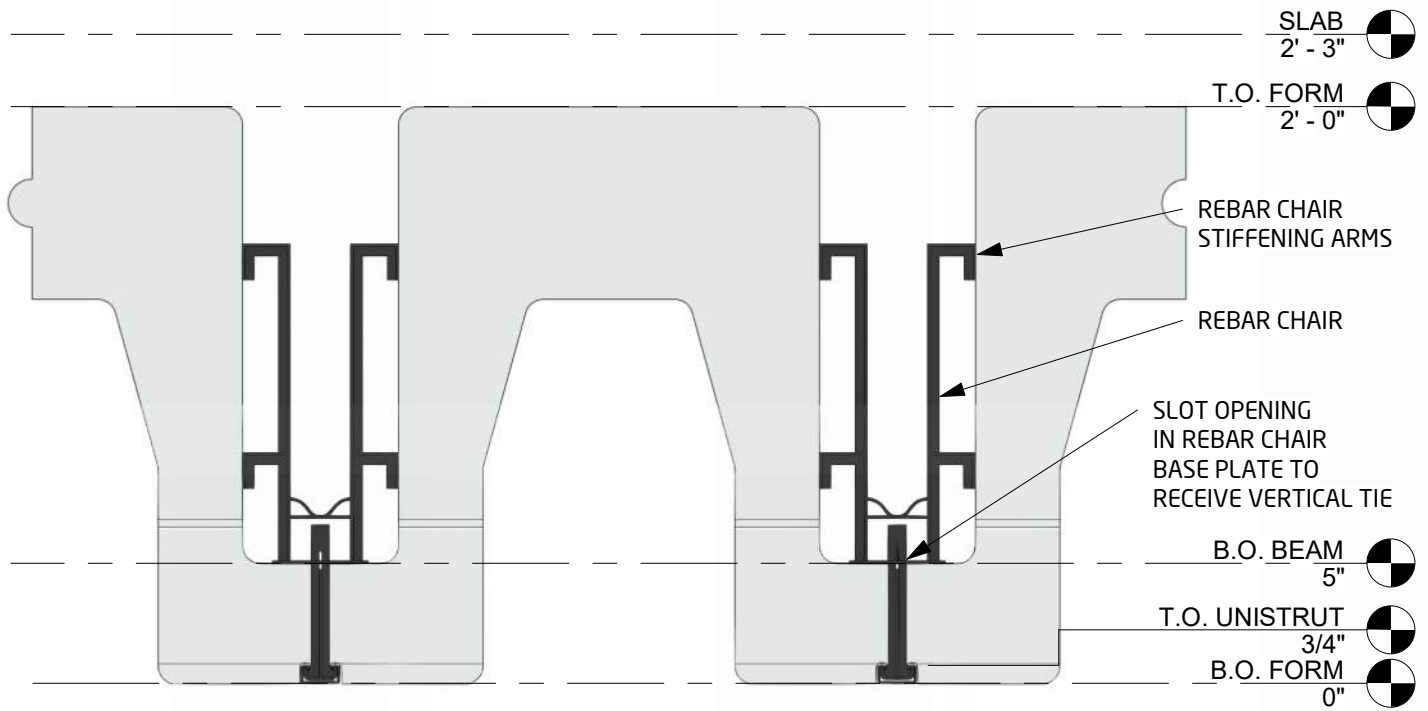

① REBAR CHAIR CROSS SECTION
1 1/2" = 1'-0"

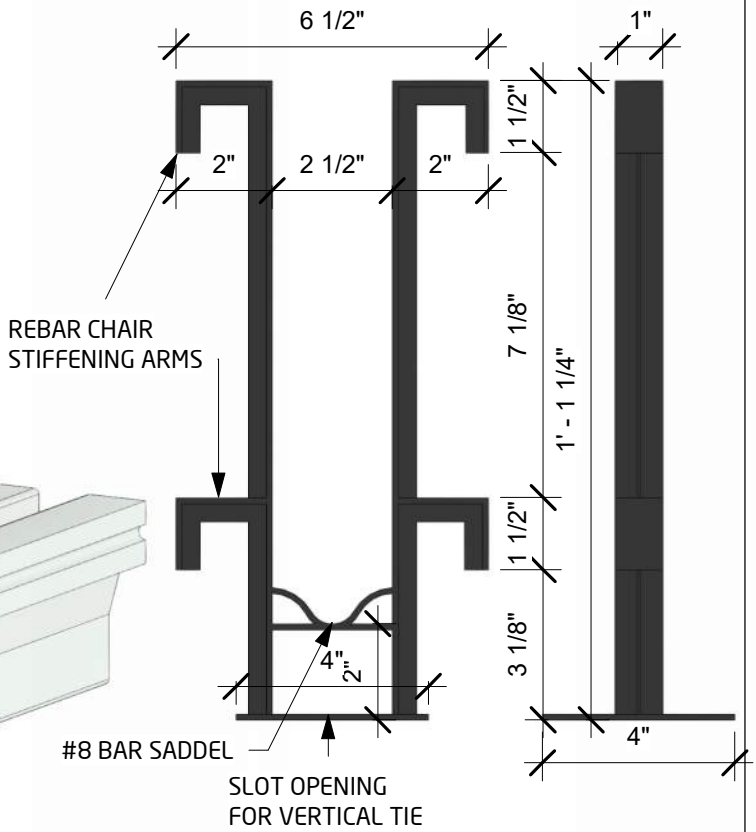

② REBAR CHAIR L & R ELEV
3" = 1'-0"

③ AXONOMETRIC REBAR CHAR VIEW

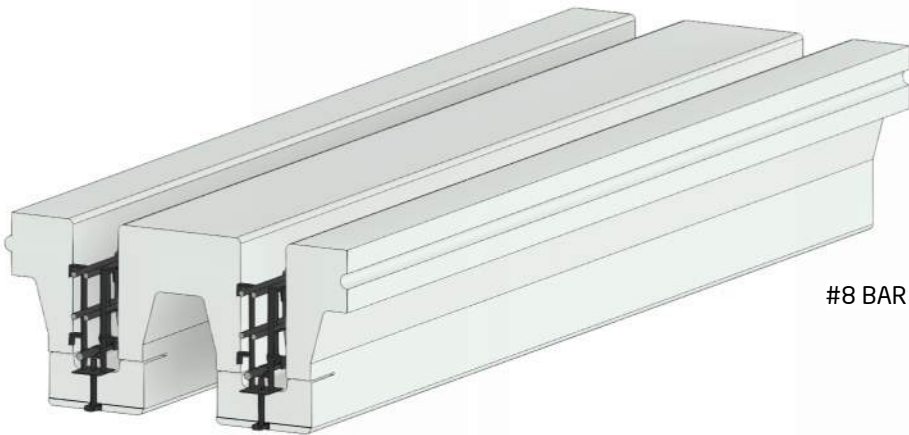

CLIMATE-DECK™
TILT-UP FORMS
50' SPAN DESIGN

(4.2) @ 24" x 48" x 144"

REBAR CHAIR

Project number	CD1848144
Date	06.12.2023
Drawn by	ALMA JESSOP
Checked by	AJ

D4.0

Scale As indicated



SLAB
2' - 3"

T.O. FORM
2' - 0"

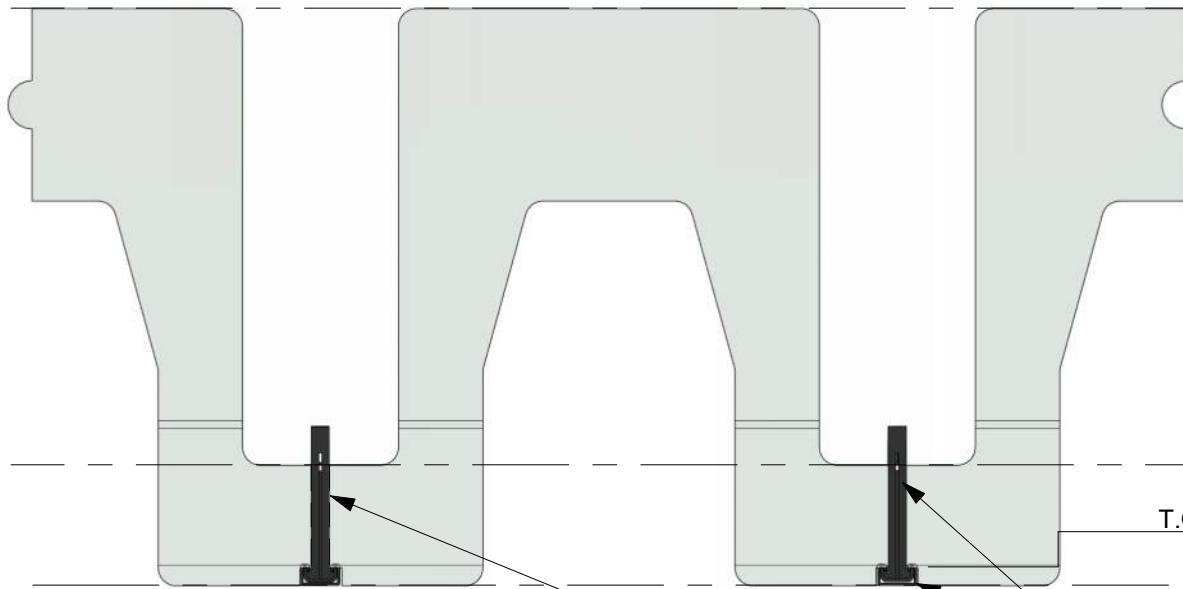

B.O. BEAM
5"

T.O. UNISTRUT
3/4"

B.O. FORM
0"

① **CEILING MEMBER CROSS SECTION**
1 1/2" = 1'-0"

INSERT VERTICAL TIE AND CEILING MEMBER INTO 1" HOLES

INSERT VERTICAL TIE INTO CEILING MEMBER

HOLES DRILLED BY OTHERS

② **UNISTRUT-CEILING MEMBER**
6" = 1'-0"

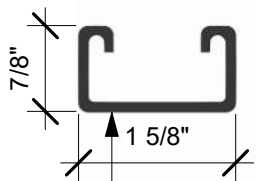

UNISTRUT-CEILING MEMBER

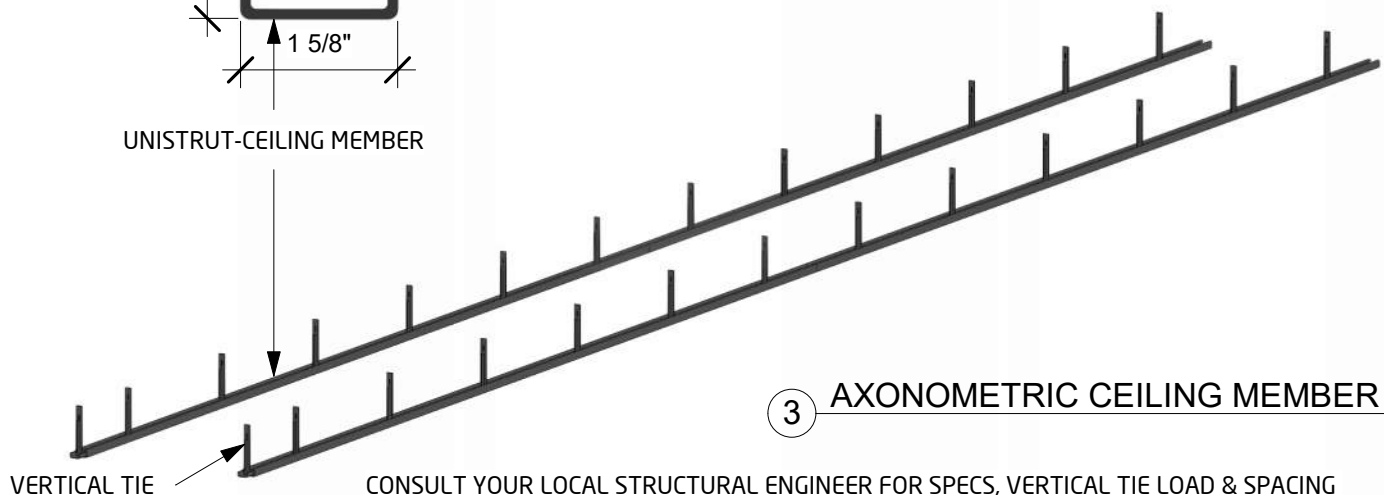

③ **AXONOMETRIC CEILING MEMBER VIEW**

VERTICAL TIE

CONSULT YOUR LOCAL STRUCTURAL ENGINEER FOR SPECS, VERTICAL TIE LOAD & SPACING



CLIMATE-DECK™
TILT-UP FORMS
50' SPAN DESIGN

(4.2) @ 24" x 48" x 144"

VERTICAL TIE

Project number CD1848144

Date 06.12.2023

Drawn by ALMA JESSOP

Checked by AJ

D2.0

Scale As indicated

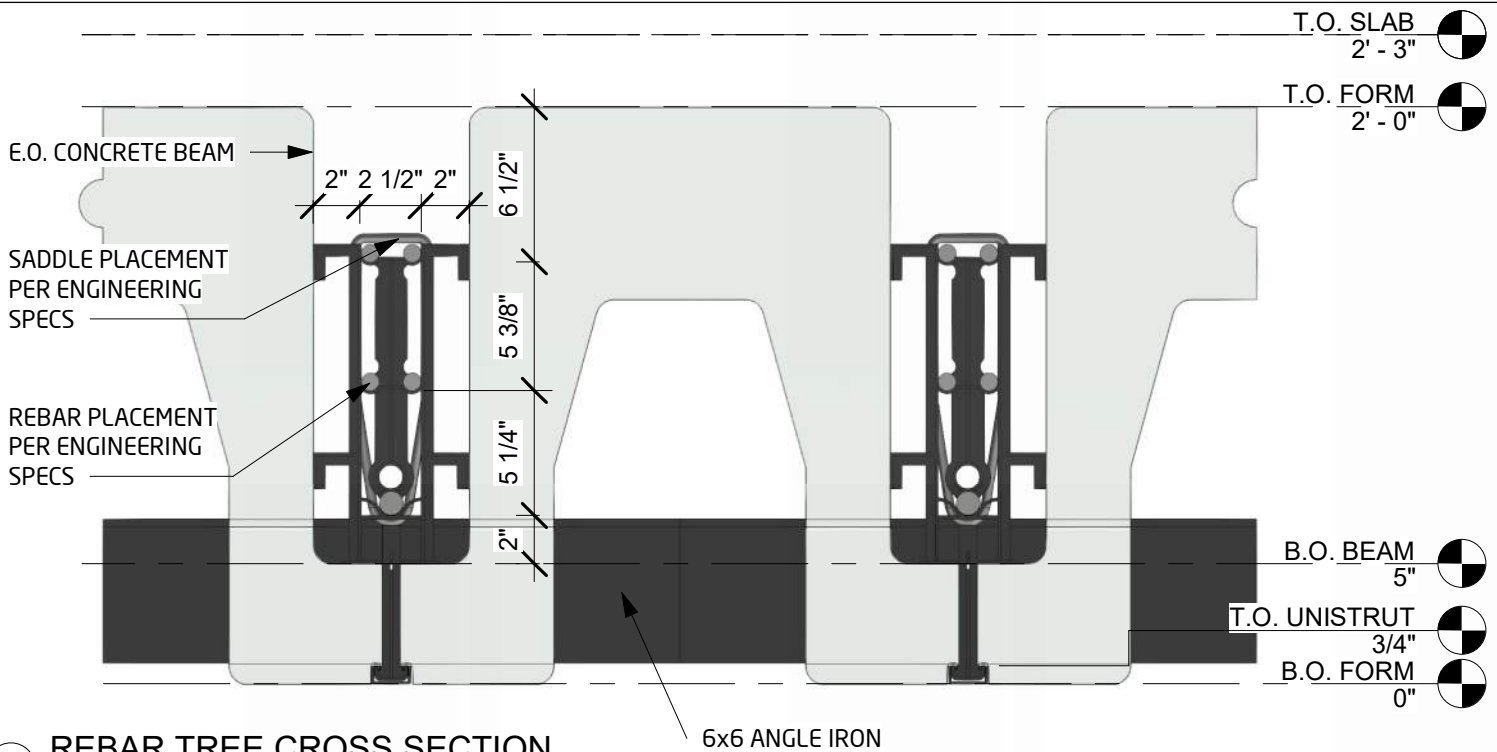

① **REBAR TREE CROSS SECTION**
1 1/2" = 1'-0"

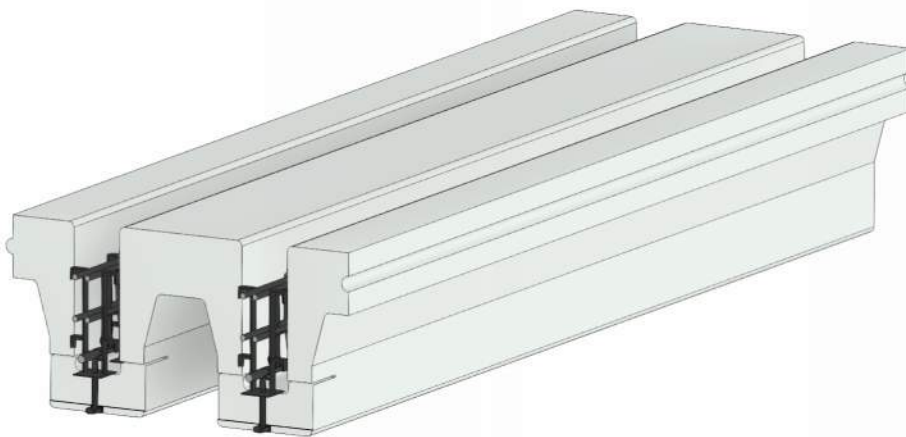

③ **AXONOMETRIC REBAR TREE VIEW**

SEE STRUCTURAL ENGINEERS SPECIFICATIONS FOR SHORING, REBAR & CONCRETE PLACEMENT.

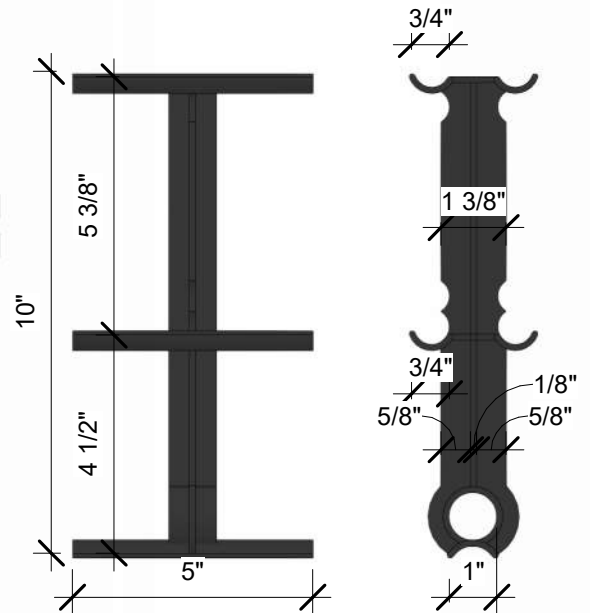

② **REBAR TREE**
3" = 1'-0"



CLIMATE-DECK™
TILT-UP FORMS
50' SPAN DESIGN

(4.2) @ 24" x 48" x 144"

REBAR TREE

Project number	CD1848144
Date	06.12.2023
Drawn by	ALMA JESSOP
Checked by	AJ

D5.0

Scale As indicated

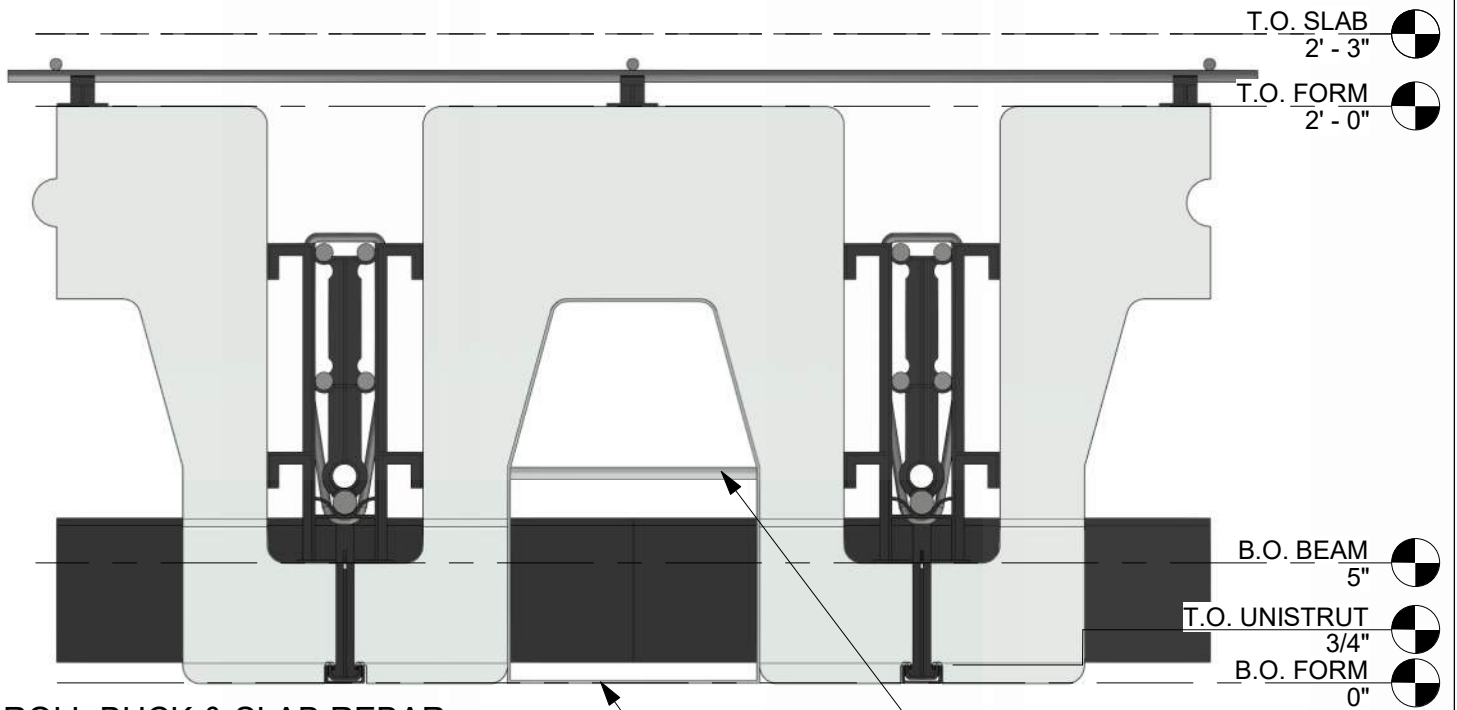

① **ROLL BUCK & SLAB REBAR**
 1 1/2" = 1'-0"

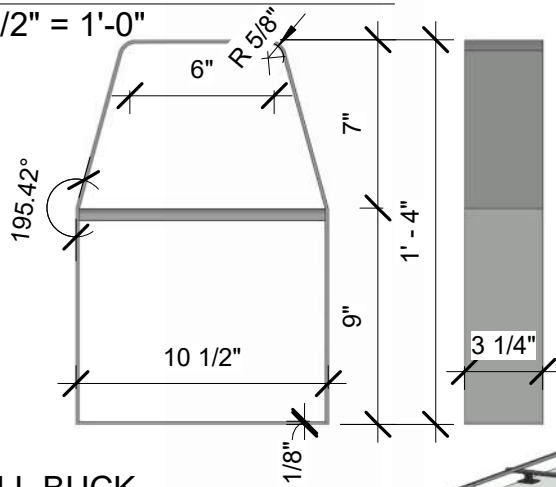

ROLL BUCKS ENSURE THE FORMS DONT ROLL DURING FORMING & CONCRETE PLACEMENT

② **ROLL BUCK**
 1 1/2" = 1'-0"

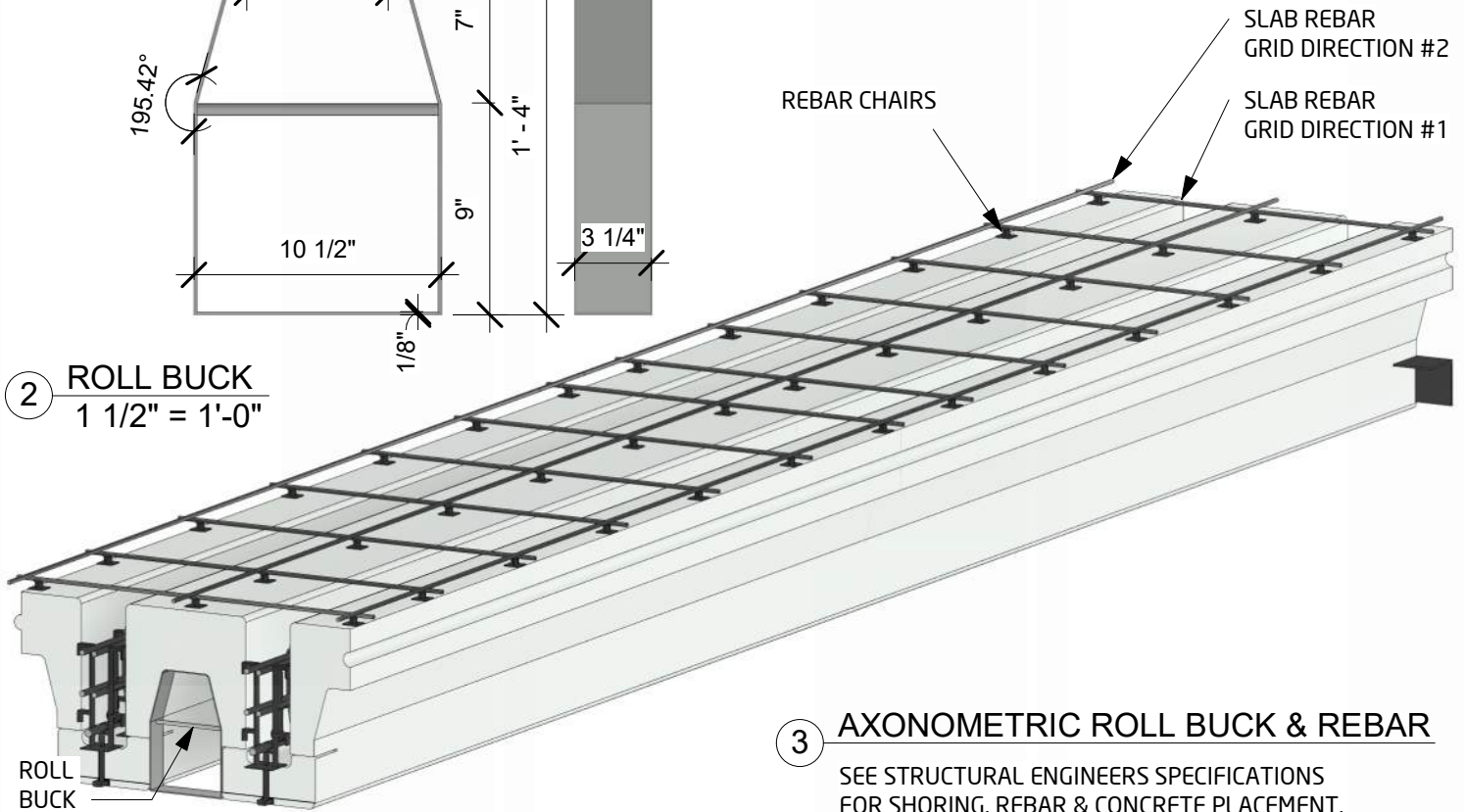

③ **AXONOMETRIC ROLL BUCK & REBAR**

SEE STRUCTURAL ENGINEERS SPECIFICATIONS FOR SHORING, REBAR & CONCRETE PLACEMENT.



CLIMATE-DECK™
 TILT-UP FORMS
 50' SPAN DESIGN

(4.2) @ 24" x 48" x 144"

ROLL BUCKS

Project number	CD1848144
Date	06.12.2023
Drawn by	ALMA JESSOP
Checked by	AJ

D6.0

Scale 1 1/2" = 1'-0"

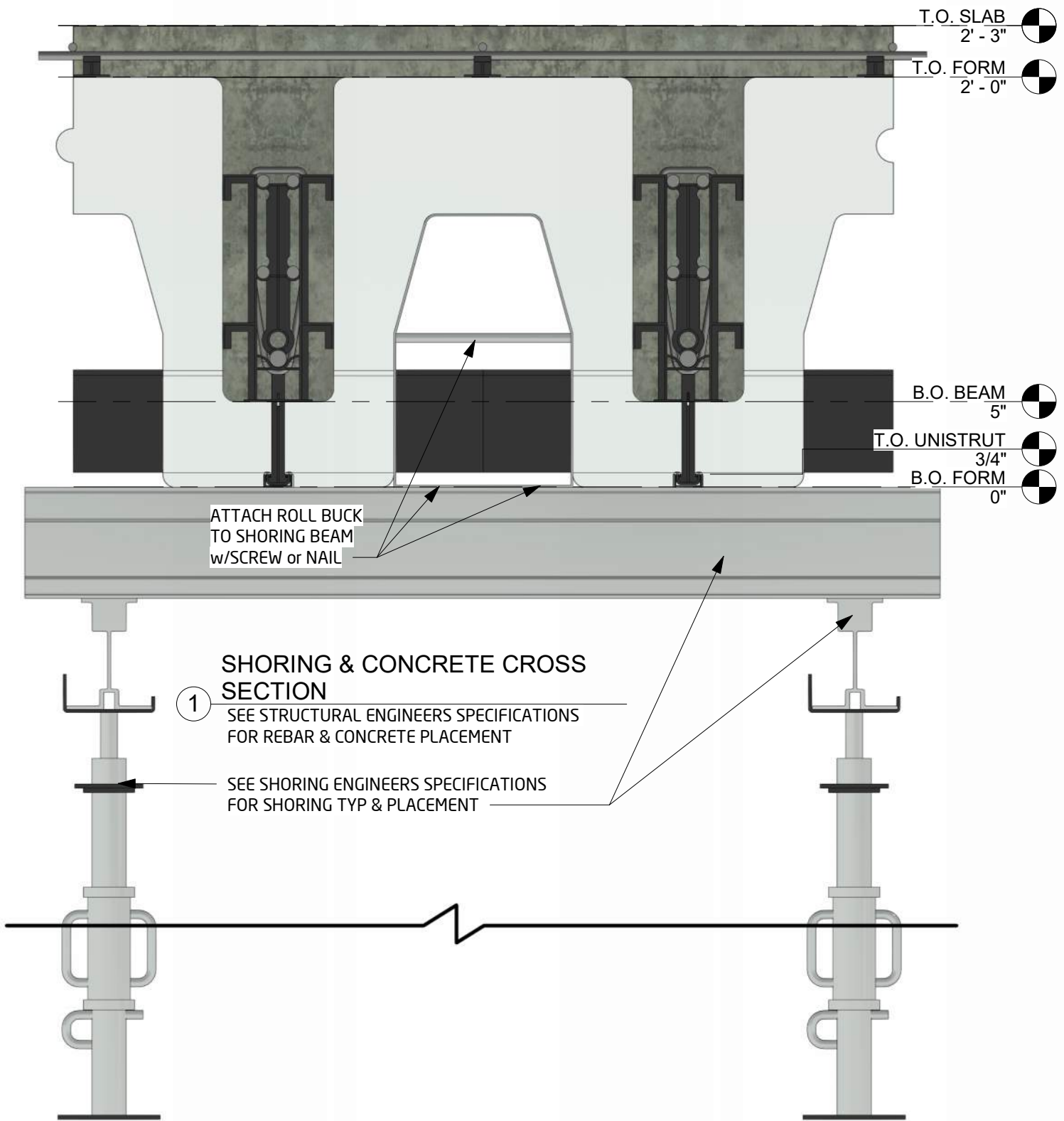

CLIMATE-DECK™
TILT-UP FORMS
50' SPAN DESIGN

(4.2) @ 24" x 48" x 144"

SHORING & CONCRETE

Project number	CD1848144
Date	06.12.2023
Drawn by	ALMA JESSOP
Checked by	AJ

D7.0

Scale 1 1/2" = 1'-0"



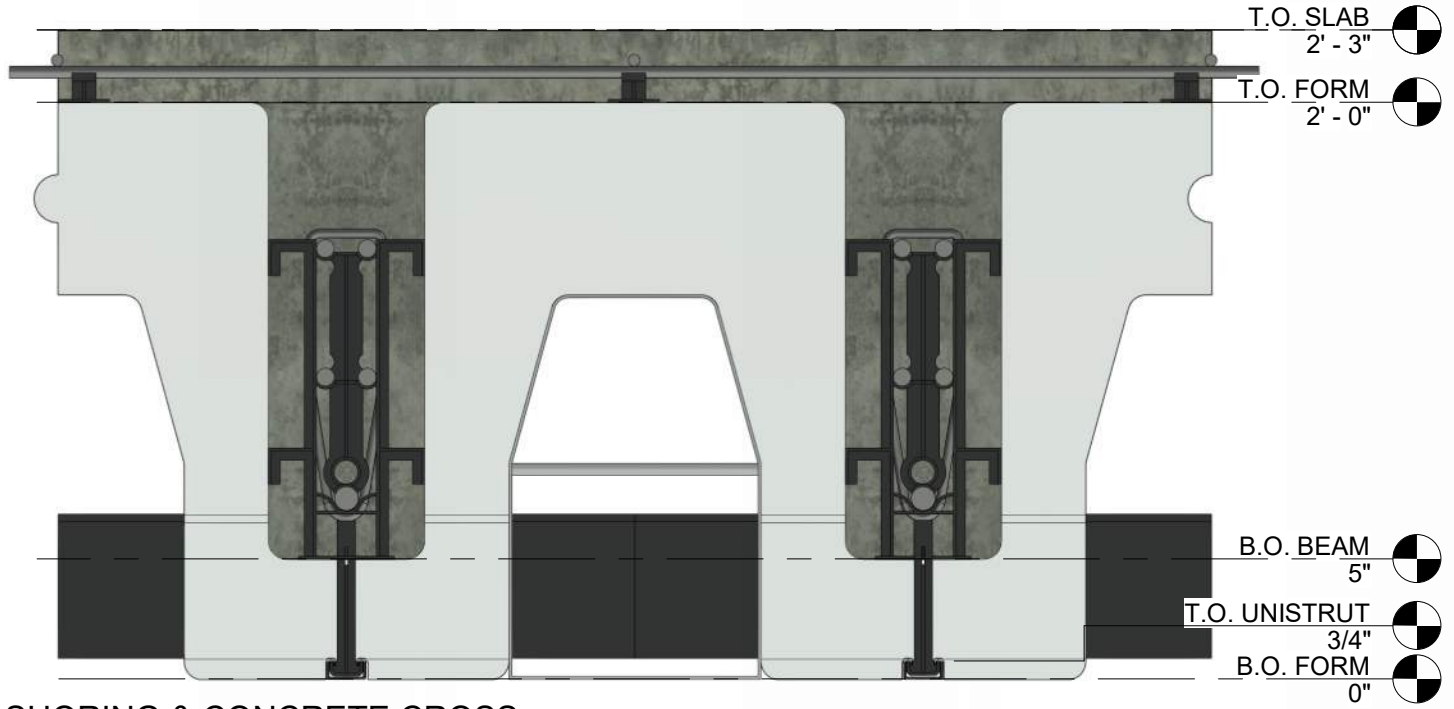

SHORING & CONCRETE CROSS SECTION 2

② 1 1/2" = 1'-0"



CLIMATE-DECK™
TILT-UP FORMS
50' SPAN DESIGN

(4.2) @ 24" x 48" x 144"

SHORING & CONCRETE

Project number	CD1848144
Date	06.12.2023
Drawn by	ALMA JESSOP
Checked by	AJ

D7.1

Scale 1 1/2" = 1'-0"

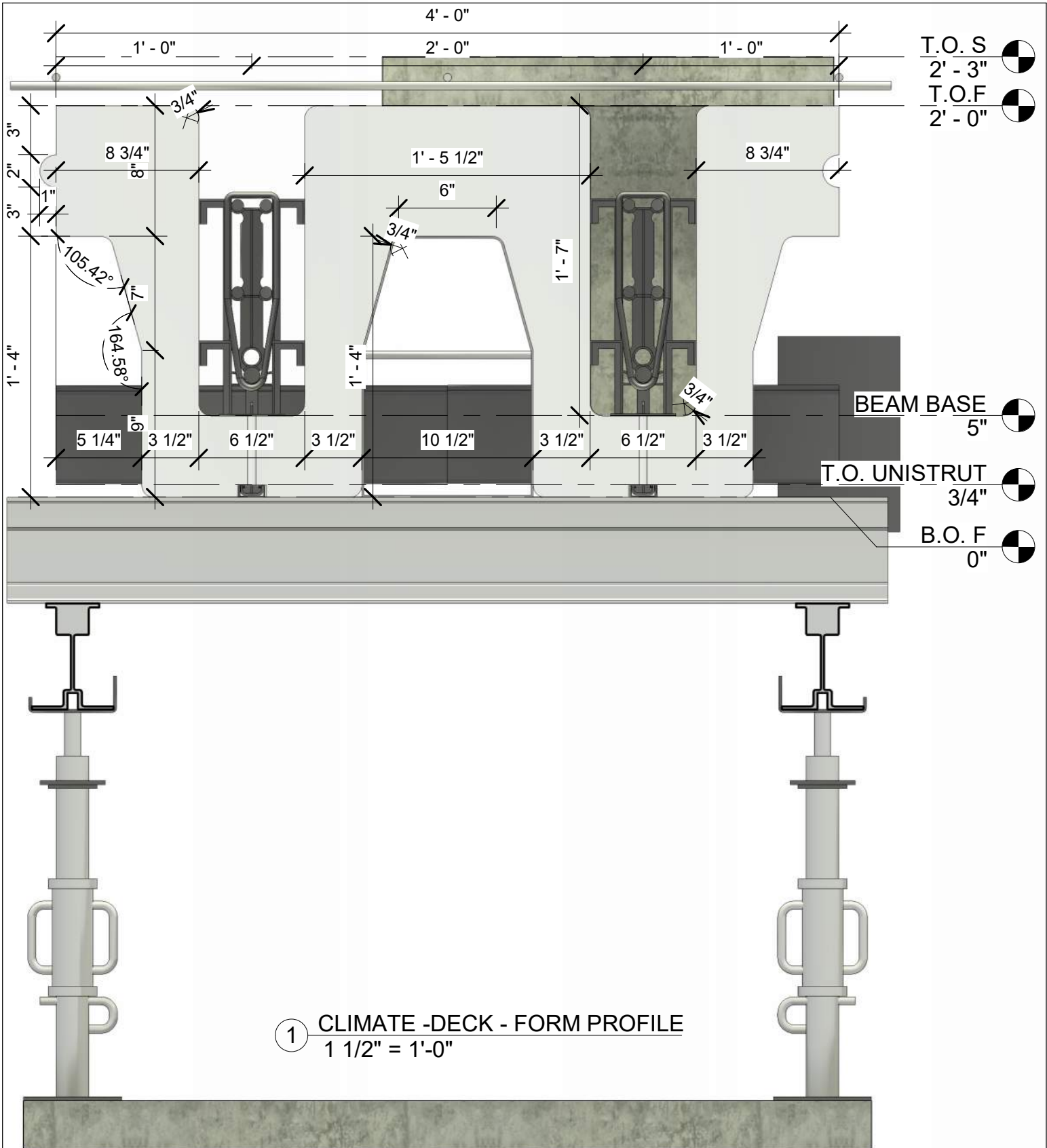

① CLIMATE -DECK - FORM PROFILE
 1 1/2" = 1'-0"



CLIMATE-DECK™
 TILT-UP FORMS
 50' SPAN DESIGN

(4.2) @ 24" x 48" x 144"

DIMENTIONAL SECTION 1

Project number	CD2448144TU
Date	06.12.2023
Drawn by	ALMA JESSOP
Checked by	AJ

D8.0

Scale 1 1/2" = 1'-0"

A

T.O. WALL
11' - 9"

NOTE: WALL HEIGHTS & THICKNESS ARE SIMULATION ONLY
CONSULT YOUR STRUCTURAL ENGINEER FOR SPECIFICATIONS

CONSULT YOUR LOCAL STRUCTURAL ENGINEER
FOR REBAR, CONCRETE & PLACEMENT SPECIFICATIONS

T.O. SLAB
10' - 9"

T.O. FORM
10' - 6"

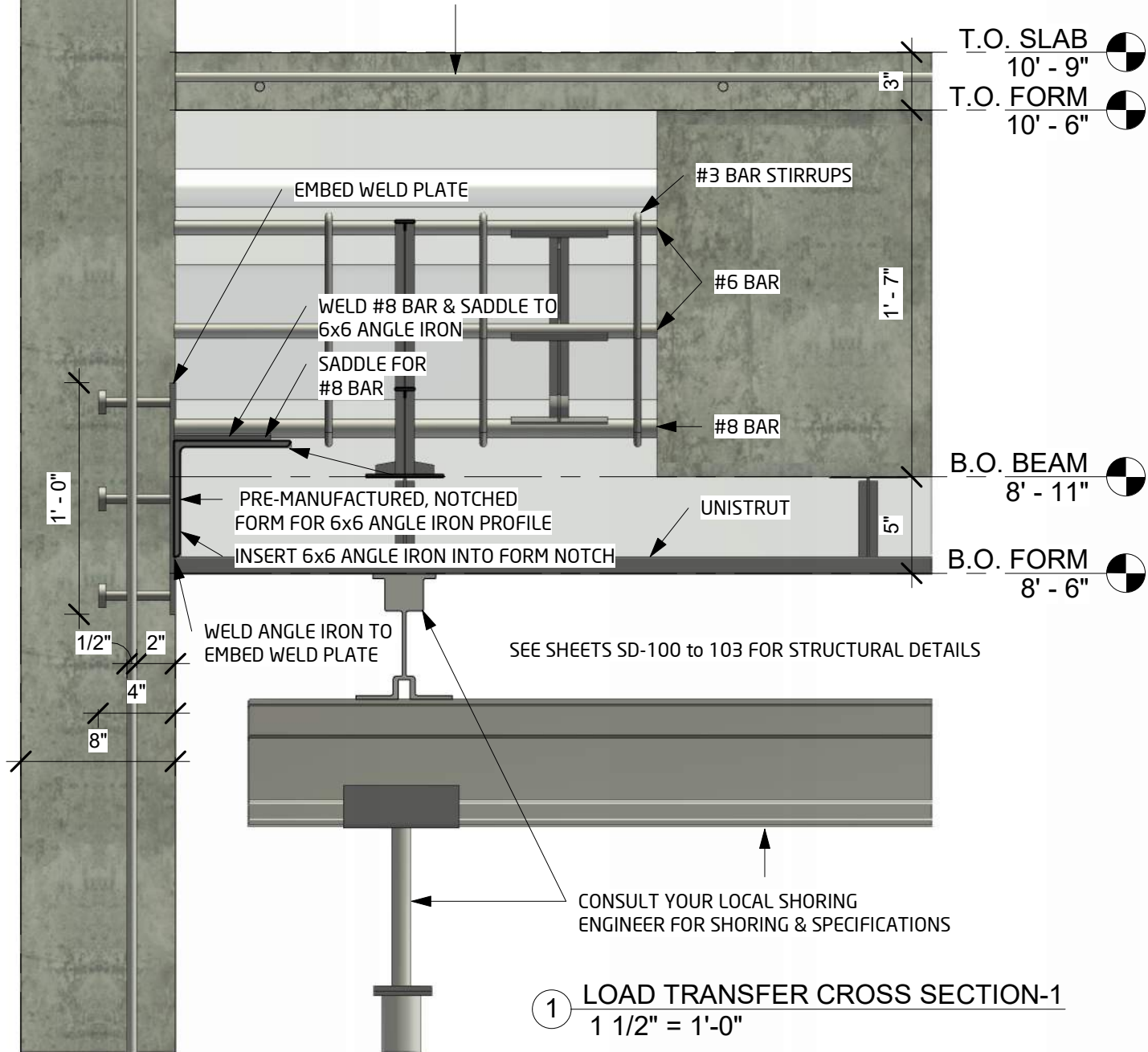

1 LOAD TRANSFER CROSS SECTION-1
1 1/2" = 1'-0"



CLIMATE-DECK™
TILT-UP FORMS
50' SPAN DESIGN

(4.2) @ 24" x 48" x 144"

CROSS SECTION 1

Project number	CD2448144TU	D8.1
Date	06.12.2023	
Drawn by	ALMA JESSOP	
Checked by	AJ	
		Scale 1 1/2" = 1'-0"

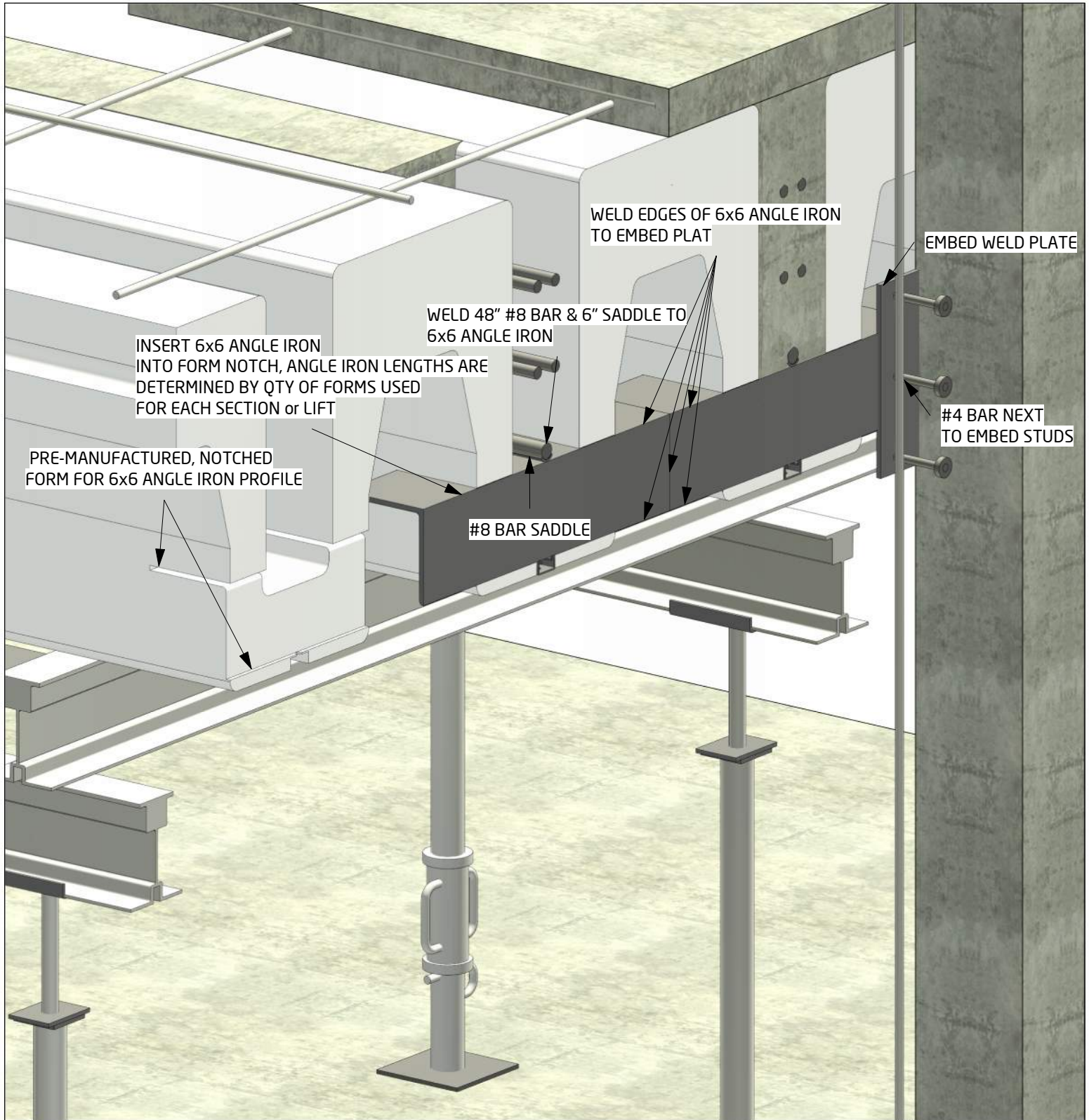

RENDERINGS ARE ILLUSTRATIONS ONLY
SEE STRUCTURAL & SHORING ENGINEERES SPECIFICATIONS FOR DETAILS

① **LOAD TRANSFER ASSEMBLY**



CLIMATE-DECK™
TILT-UP FORMS
50' SPAN DESIGN

(4.2) @ 24" x 48" x 144"

BEAM TO WALL DETAIL

Project number	CD2448144TU	D8.2
Date	06.12.2023	
Drawn by	ALMA JESSOP	Scale
Checked by	AJ	

A

T.O. WALL
11' - 9" 

CLIMATE-DECK™ | REBAR RETENTION SYSTEMS ARE MADE FROM INCREDIBLY DURABLE PLASTICS

T.O. SLAB
10' - 9" 

T.O. FORM
10' - 6" 

CLIMATE-DECK™ EDGE FORM T&G

CLIMATE-DECK™ REBAR TREE W/ ATTACHMENT SADDLES

CLIMATE-DECK™ REBAR CHAIR

B.O. BEAM
8' - 11" 

CLIMATE-DECK™ LOCKING PIN WEDGE

B.O. FORM
8' - 6" 

CLIMATE-DECK™ VERTICAL TIE

① CLIMATE DECK - RETENTION SYSTEM
1 1/2" = 1'-0"

CONSULT YOUR LOCAL STRUCTURAL ENGINEER FOR SPECS



CLIMATE-DECK™
TILT-UP FORMS
50' SPAN DESIGN

(4.2) @ 24" x 48" x 144"

RETENTION SYSTEM

Project number	CD2448144TU	D8.3
Date	06.12.2023	
Drawn by	ALMA JESSOP	
Checked by	AJ	
		Scale 1 1/2" = 1'-0"

1

NOTE: WALL HEIGHTS & THICKNESS ARE SIMULATION ONLY
CONSULT YOUR STRUCTURAL ENGINEER FOR SPECIFICATIONS

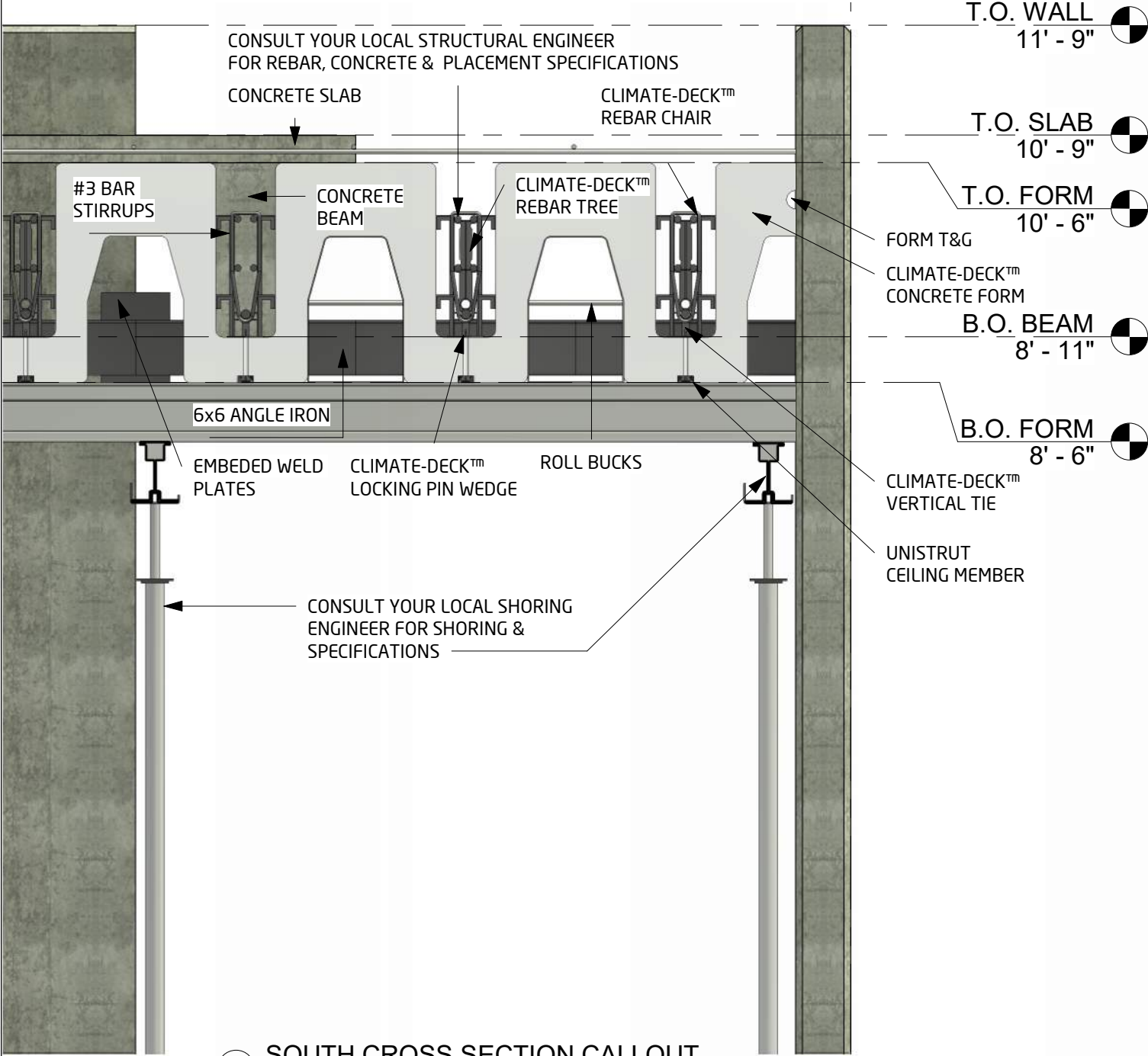

1 SOUTH CROSS SECTION CALLOUT
3/4" = 1'-0"



CLIMATE-DECK™
TILT-UP FORMS
50' SPAN DESIGN

(4.2) @ 24" x 48" x 144"

CROSS SECTION B		D8.4
Project number	CD2448144TU	
Date	06.12.2023	
Drawn by	ALMA JESSOP	
Checked by	AJ	Scale 3/4" = 1'-0"

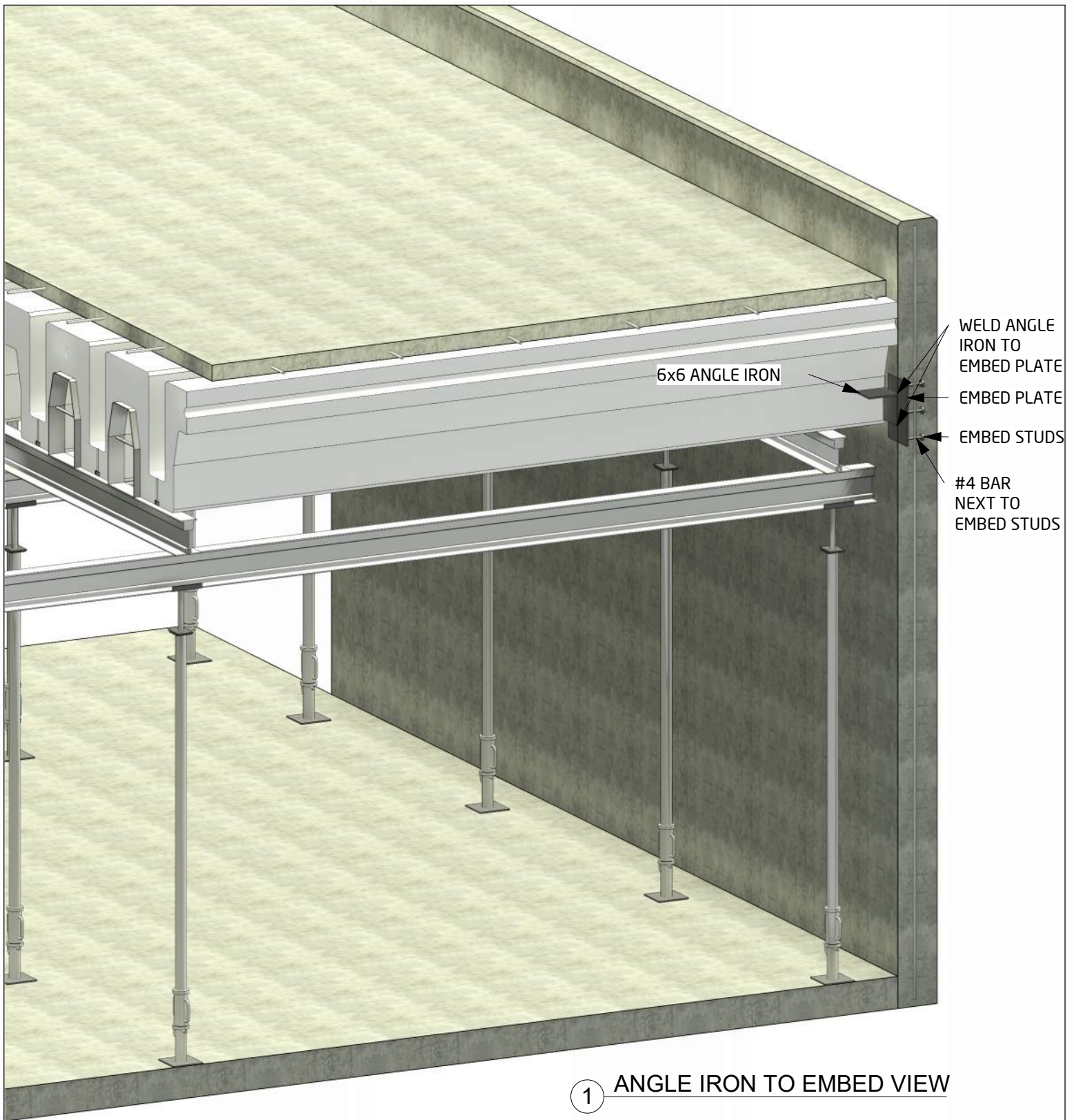

SEE STRUCTURAL ENGINEERING SPECS FOR DETAILS



CLIMATE-DECK™
TILT-UP FORMS
50' SPAN DESIGN

(4.2) @ 24" x 48" x 144"

6"x6" ANGLE TO EMBED

Project number	CD2448144TU
Date	06.12.2023
Drawn by	ALMA JESSOP
Checked by	AJ

D8.5

Scale

Concrete Beam

Lic. # : KW-06014113

File: Concrete floor design.ec6
Software copyright ENERCALC, INC. 1983-2020, Build:12.20.8.2
Site Serve LLC

DESCRIPTION: typ 50' span 3" slab square shape

CODE REFERENCES

Calculations per ACI 318-14, IBC 2018, CBC 2019, ASCE 7-16
Load Combination Set : ASCE 7-16

Material Properties

f_c	=	60.0 ksi	ϕ Phi Values	Flexure :	0.90
$f_r = f_c^{1/2} * 7.50$	=	1,837.12 psi		Shear :	0.750
Ψ Density	=	145.0 pcf	β_1	=	0.650
λ LtWt Factor	=	1.0			
Elastic Modulus	=	3,122.0 ksi	F_y - Stirrups	=	40.0 ksi
f_y - Main Rebar	=	60.0 ksi	E - Stirrups	=	29,000.0 ksi
E - Main Rebar	=	29,000.0 ksi	Stirrup Bar Size #	=	3
			Number of Resisting Legs Per Stirrup =	=	2

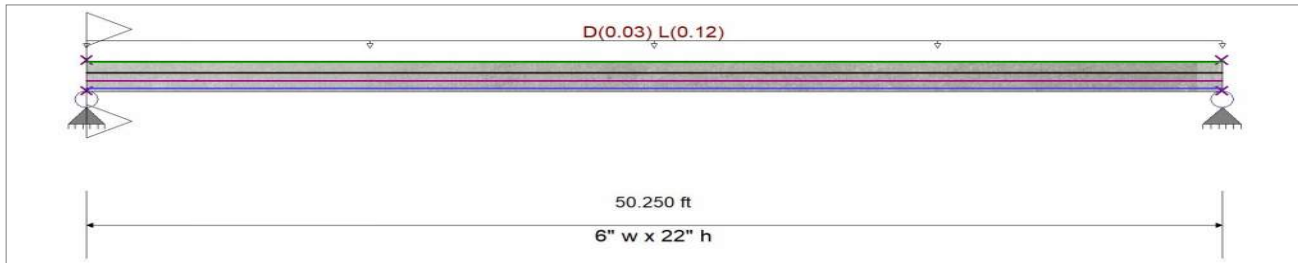
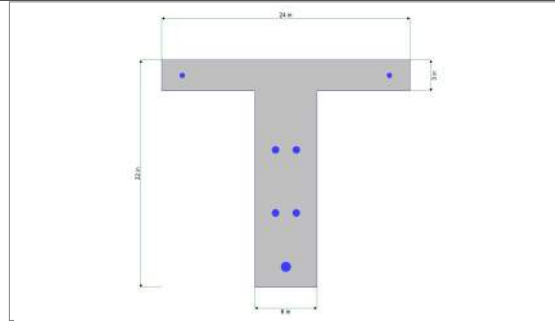

Cross Section & Reinforcing Details

Tee Section, Stem Width = 6.0 in, Total Height = 22.0 in, Top Flange Width = 24.0 in, Flange Thickness = 3.0 in

Span #1 Reinforcing...

1-#8 at 2.0 in from Bottom, from 0.0 to 50.250 ft in this span
2-#6 at 7.20 in from Bottom, from 0.0 to 50.250 ft in this span

2-#4 at 1.50 in from Top, from 0.0 to 50.250 ft in this span
2-#6 at 8.70 in from Top, from 0.0 to 50.250 ft in this span

Beam self weight calculated and added to loads

Load for Span Number 1

Uniform Load : D = 0.0150, L = 0.060 ksf, Tributary Width = 2.0 ft

DESIGN SUMMARY

Design OK

Maximum Bending Stress Ratio =	0.861 : 1	Maximum Deflection	
Section used for this span	Typical Section	Max Downward Transient Deflection	0.625 in Ratio = 965 >=360.
Mu : Applied	142.902 k-ft	Max Upward Transient Deflection	0.000 in Ratio = 0 <360.0
Mn * Phi : Allowable	165.90 k-ft	Max Downward Total Deflection	1.894 in Ratio = 318 >=150.
Location of maximum on span	25.171 ft	Max Upward Total Deflection	0.000 in Ratio = 0 <150.0
Span # where maximum occurs	Span # 1		

Vertical Reactions

Support notation : Far left is #1

Load Combination	Support 1	Support 2
Overall MAXimum	8.474	8.474
Overall MINimum	3.015	3.015
+D+H	5.459	5.459
+D+L+H	8.474	8.474
+D+Lr+H	5.459	5.459
+D+S+H	5.459	5.459
+D+0.750Lr+0.750L+H	7.721	7.721
+D+0.750L+0.750S+H	7.721	7.721
+D+0.60W+H	5.459	5.459
+D+0.750Lr+0.750L+0.450W+H	7.721	7.721
+D+0.750L+0.750S+0.450W+H	7.721	7.721
+0.60D+0.60W+0.60H	3.276	3.276



CLIMATE-DECK™
TILT-UP FORMS
50' SPAN DESIGN

(4.2) @ 24" x 48" x 144"

STRUCTURAL DETAILS

Project number	CD2448144TU	SD-100
Date	06.12.2023	
Drawn by	Author	Scale
Checked by	Checker	

Concrete Beam

Lic. # : KW-06014113

File: Concrete floor design.ec6
Software copyright ENERCALC, INC. 1983-2020, Build:12.20.8.2
Site Serve LLC

DESCRIPTION: typ 50' span 3" slab square shape

Vertical Reactions

Support notation : Far left is #1

Load Combination	Support 1	Support 2
+D+0.70E+0.60H	5.459	5.459
+D+0.750L+0.750S+0.5250E+H	7.721	7.721
+0.60D+0.70E+H	3.276	3.276
D Only	5.459	5.459
L Only	3.015	3.015
H Only		

Detailed Shear Information

Load Combination	Span Number	Distance (ft)	'd' (in)	Vu (k) Actual	Vu (k) Design	Mu (k-ft)	d*Vu/Mu	Phi*Vc (k)	Comment	Phi*Vs (k)	Phi*Vn (k)	Spacing (in) Req'd	Spacing (in) Suggest
+1.20D+1.60L+0.50S+1.60H	1	0.00	20.00	11.38	11.38	0.00	1.00	46.67	Vu < PhiVc/2	lot Req'd 9.6.	46.7	0.0	0.0
+1.20D+1.60L+0.50S+1.60H	1	0.55	20.00	11.13	11.13	6.18	1.00	46.67	Vu < PhiVc/2	lot Req'd 9.6.	46.7	0.0	0.0
+1.20D+1.60L+0.50S+1.60H	1	1.10	20.00	10.88	10.88	12.22	1.00	46.67	Vu < PhiVc/2	lot Req'd 9.6.	46.7	0.0	0.0
+1.20D+1.60L+0.50S+1.60H	1	1.65	20.00	10.63	10.63	18.13	0.98	46.56	Vu < PhiVc/2	lot Req'd 9.6.	46.6	0.0	0.0
+1.20D+1.60L+0.50S+1.60H	1	2.20	20.00	10.38	10.38	23.90	0.72	45.35	Vu < PhiVc/2	lot Req'd 9.6.	45.3	0.0	0.0
+1.20D+1.60L+0.50S+1.60H	1	2.75	20.00	10.13	10.13	29.53	0.57	44.62	Vu < PhiVc/2	lot Req'd 9.6.	44.6	0.0	0.0
+1.20D+1.60L+0.50S+1.60H	1	3.30	20.00	9.88	9.88	35.02	0.47	44.13	Vu < PhiVc/2	lot Req'd 9.6.	44.1	0.0	0.0
+1.20D+1.60L+0.50S+1.60H	1	3.84	20.00	9.63	9.63	40.38	0.40	43.79	Vu < PhiVc/2	lot Req'd 9.6.	43.8	0.0	0.0
+1.20D+1.60L+0.50S+1.60H	1	4.39	20.00	9.39	9.39	45.61	0.34	43.53	Vu < PhiVc/2	lot Req'd 9.6.	43.5	0.0	0.0
+1.20D+1.60L+0.50S+1.60H	1	4.94	20.00	9.14	9.14	50.69	0.30	43.32	Vu < PhiVc/2	lot Req'd 9.6.	43.3	0.0	0.0
+1.20D+1.60L+0.50S+1.60H	1	5.49	20.00	8.89	8.89	55.64	0.27	43.16	Vu < PhiVc/2	lot Req'd 9.6.	43.2	0.0	0.0
+1.20D+1.60L+0.50S+1.60H	1	6.04	20.00	8.64	8.64	60.46	0.24	43.03	Vu < PhiVc/2	lot Req'd 9.6.	43.0	0.0	0.0
+1.20D+1.60L+0.50S+1.60H	1	6.59	20.00	8.39	8.39	65.13	0.21	42.91	Vu < PhiVc/2	lot Req'd 9.6.	42.9	0.0	0.0
+1.20D+1.60L+0.50S+1.60H	1	7.14	20.00	8.14	8.14	69.67	0.19	42.82	Vu < PhiVc/2	lot Req'd 9.6.	42.8	0.0	0.0
+1.20D+1.60L+0.50S+1.60H	1	7.69	20.00	7.89	7.89	74.08	0.18	42.74	Vu < PhiVc/2	lot Req'd 9.6.	42.7	0.0	0.0
+1.20D+1.60L+0.50S+1.60H	1	8.24	20.00	7.65	7.65	78.34	0.16	42.66	Vu < PhiVc/2	lot Req'd 9.6.	42.7	0.0	0.0
+1.20D+1.60L+0.50S+1.60H	1	8.79	20.00	7.40	7.40	82.48	0.15	42.60	Vu < PhiVc/2	lot Req'd 9.6.	42.6	0.0	0.0
+1.20D+1.60L+0.50S+1.60H	1	9.34	20.00	7.15	7.15	86.47	0.14	42.55	Vu < PhiVc/2	lot Req'd 9.6.	42.5	0.0	0.0
+1.20D+1.60L+0.50S+1.60H	1	9.89	20.00	6.90	6.90	90.33	0.13	42.49	Vu < PhiVc/2	lot Req'd 9.6.	42.5	0.0	0.0
+1.20D+1.60L+0.50S+1.60H	1	10.43	20.00	6.65	6.65	94.05	0.12	42.45	Vu < PhiVc/2	lot Req'd 9.6.	42.4	0.0	0.0
+1.20D+1.60L+0.50S+1.60H	1	10.98	20.00	6.40	6.40	97.63	0.11	42.41	Vu < PhiVc/2	lot Req'd 9.6.	42.4	0.0	0.0
+1.20D+1.60L+0.50S+1.60H	1	11.53	20.00	6.15	6.15	101.08	0.10	42.37	Vu < PhiVc/2	lot Req'd 9.6.	42.4	0.0	0.0
+1.20D+1.60L+0.50S+1.60H	1	12.08	20.00	5.91	5.91	104.39	0.09	42.34	Vu < PhiVc/2	lot Req'd 9.6.	42.3	0.0	0.0
+1.20D+1.60L+0.50S+1.60H	1	12.63	20.00	5.66	5.66	107.57	0.09	42.31	Vu < PhiVc/2	lot Req'd 9.6.	42.3	0.0	0.0
+1.20D+1.60L+0.50S+1.60H	1	13.18	20.00	5.41	5.41	110.60	0.08	42.28	Vu < PhiVc/2	lot Req'd 9.6.	42.3	0.0	0.0
+1.20D+1.60L+0.50S+1.60H	1	13.73	20.00	5.16	5.16	113.51	0.08	42.25	Vu < PhiVc/2	lot Req'd 9.6.	42.2	0.0	0.0
+1.20D+1.60L+0.50S+1.60H	1	14.28	20.00	4.91	4.91	116.27	0.07	42.22	Vu < PhiVc/2	lot Req'd 9.6.	42.2	0.0	0.0
+1.20D+1.60L+0.50S+1.60H	1	14.83	20.00	4.66	4.66	118.90	0.07	42.20	Vu < PhiVc/2	lot Req'd 9.6.	42.2	0.0	0.0
+1.20D+1.60L+0.50S+1.60H	1	15.38	20.00	4.41	4.41	121.39	0.06	42.18	Vu < PhiVc/2	lot Req'd 9.6.	42.2	0.0	0.0
+1.20D+1.60L+0.50S+1.60H	1	15.93	20.00	4.16	4.16	123.75	0.06	42.15	Vu < PhiVc/2	lot Req'd 9.6.	42.2	0.0	0.0
+1.20D+1.60L+0.50S+1.60H	1	16.48	20.00	3.92	3.92	125.97	0.05	42.13	Vu < PhiVc/2	lot Req'd 9.6.	42.1	0.0	0.0
+1.20D+1.60L+0.50S+1.60H	1	17.02	20.00	3.67	3.67	128.05	0.05	42.11	Vu < PhiVc/2	lot Req'd 9.6.	42.1	0.0	0.0
+1.20D+1.60L+0.50S+1.60H	1	17.57	20.00	3.42	3.42	129.99	0.04	42.10	Vu < PhiVc/2	lot Req'd 9.6.	42.1	0.0	0.0
+1.20D+1.60L+0.50S+1.60H	1	18.12	20.00	3.17	3.17	131.80	0.04	42.08	Vu < PhiVc/2	lot Req'd 9.6.	42.1	0.0	0.0
+1.20D+1.60L+0.50S+1.60H	1	18.67	20.00	2.92	2.92	133.48	0.04	42.06	Vu < PhiVc/2	lot Req'd 9.6.	42.1	0.0	0.0
+1.20D+1.60L+0.50S+1.60H	1	19.22	20.00	2.67	2.67	135.01	0.03	42.04	Vu < PhiVc/2	lot Req'd 9.6.	42.0	0.0	0.0
+1.20D+1.60L+0.50S+1.60H	1	19.77	20.00	2.42	2.42	136.41	0.03	42.03	Vu < PhiVc/2	lot Req'd 9.6.	42.0	0.0	0.0
+1.20D+1.60L+0.50S+1.60H	1	20.32	20.00	2.18	2.18	137.68	0.03	42.01	Vu < PhiVc/2	lot Req'd 9.6.	42.0	0.0	0.0
+1.20D+1.60L+0.50S+1.60H	1	20.87	20.00	1.93	1.93	138.80	0.02	42.00	Vu < PhiVc/2	lot Req'd 9.6.	42.0	0.0	0.0
+1.20D+1.60L+0.50S+1.60H	1	21.42	20.00	1.68	1.68	139.79	0.02	41.98	Vu < PhiVc/2	lot Req'd 9.6.	42.0	0.0	0.0
+1.20D+1.60L+0.50S+1.60H	1	21.97	20.00	1.43	1.43	140.65	0.02	41.97	Vu < PhiVc/2	lot Req'd 9.6.	42.0	0.0	0.0
+1.20D+1.60L+0.50S+1.60H	1	22.52	20.00	1.18	1.18	141.36	0.01	41.95	Vu < PhiVc/2	lot Req'd 9.6.	42.0	0.0	0.0
+1.20D+1.60L+0.50S+1.60H	1	23.07	20.00	0.93	0.93	141.94	0.01	41.94	Vu < PhiVc/2	lot Req'd 9.6.	41.9	0.0	0.0
+1.20D+1.60L+0.50S+1.60H	1	23.61	20.00	0.68	0.68	142.39	0.01	41.92	Vu < PhiVc/2	lot Req'd 9.6.	41.9	0.0	0.0
+1.20D+1.60L+0.50S+1.60H	1	24.16	20.00	0.44	0.44	142.69	0.01	41.91	Vu < PhiVc/2	lot Req'd 9.6.	41.9	0.0	0.0
+1.20D+1.60L+0.50S+1.60H	1	24.71	20.00	0.19	0.19	142.86	0.00	41.90	Vu < PhiVc/2	lot Req'd 9.6.	41.9	0.0	0.0



CLIMATE-DECK™
TILT-UP FORMS
50' SPAN DESIGN

(4.2) @ 24" x 48" x 144"

STRUCTURAL DETAILS

Project number	CD2448144TU	SD-101
Date	06.12.2023	
Drawn by	Author	
Checked by	Checker	
		Scale

Concrete Beam

Lic. #: KW-06014113

File: Concrete floor design.ec6
Software copyright ENERCALC, INC. 1983-2020, Build:12.20.8.2
Site Serve LLC

DESCRIPTION: typ 50' span 3" slab square shape

Detailed Shear Information

Load Combination	Span Number	Distance (ft)	'd' (in)	Vu (k) Actual	Vu (k) Design	Mu (k-ft)	d*Vu/Mu	Phi*Vc (k)	Comment	Phi*Vs (k)	Phi*Vn (k)	Spacing (in) Req'd Suggest
+1.20D+1.60L+0.50S+1.60H	1	25.26	20.00	-0.06	0.06	142.90	0.00	41.89	Vu < PhiVc/2	lot Req'd 9.6.	41.9	0.0 0.0
+1.20D+1.60L+0.50S+1.60H	1	25.81	20.00	-0.31	0.31	142.80	0.00	41.90	Vu < PhiVc/2	lot Req'd 9.6.	41.9	0.0 0.0
+1.20D+1.60L+0.50S+1.60H	1	26.36	20.00	-0.56	0.56	142.56	0.01	41.92	Vu < PhiVc/2	lot Req'd 9.6.	41.9	0.0 0.0
+1.20D+1.60L+0.50S+1.60H	1	26.91	20.00	-0.81	0.81	142.18	0.01	41.93	Vu < PhiVc/2	lot Req'd 9.6.	41.9	0.0 0.0
+1.20D+1.60L+0.50S+1.60H	1	27.46	20.00	-1.06	1.06	141.67	0.01	41.95	Vu < PhiVc/2	lot Req'd 9.6.	41.9	0.0 0.0
+1.20D+1.60L+0.50S+1.60H	1	28.01	20.00	-1.31	1.31	141.02	0.02	41.96	Vu < PhiVc/2	lot Req'd 9.6.	42.0	0.0 0.0
+1.20D+1.60L+0.50S+1.60H	1	28.56	20.00	-1.55	1.55	140.24	0.02	41.97	Vu < PhiVc/2	lot Req'd 9.6.	42.0	0.0 0.0
+1.20D+1.60L+0.50S+1.60H	1	29.11	20.00	-1.80	1.80	139.31	0.02	41.99	Vu < PhiVc/2	lot Req'd 9.6.	42.0	0.0 0.0
+1.20D+1.60L+0.50S+1.60H	1	29.66	20.00	-2.05	2.05	138.26	0.02	42.00	Vu < PhiVc/2	lot Req'd 9.6.	42.0	0.0 0.0
+1.20D+1.60L+0.50S+1.60H	1	30.20	20.00	-2.30	2.30	137.06	0.03	42.02	Vu < PhiVc/2	lot Req'd 9.6.	42.0	0.0 0.0
+1.20D+1.60L+0.50S+1.60H	1	30.75	20.00	-2.55	2.55	135.73	0.03	42.04	Vu < PhiVc/2	lot Req'd 9.6.	42.0	0.0 0.0
+1.20D+1.60L+0.50S+1.60H	1	31.30	20.00	-2.80	2.80	134.26	0.03	42.05	Vu < PhiVc/2	lot Req'd 9.6.	42.1	0.0 0.0
+1.20D+1.60L+0.50S+1.60H	1	31.85	20.00	-3.05	3.05	132.66	0.04	42.07	Vu < PhiVc/2	lot Req'd 9.6.	42.1	0.0 0.0
+1.20D+1.60L+0.50S+1.60H	1	32.40	20.00	-3.29	3.29	130.92	0.04	42.09	Vu < PhiVc/2	lot Req'd 9.6.	42.1	0.0 0.0
+1.20D+1.60L+0.50S+1.60H	1	32.95	20.00	-3.54	3.54	129.04	0.05	42.11	Vu < PhiVc/2	lot Req'd 9.6.	42.1	0.0 0.0
+1.20D+1.60L+0.50S+1.60H	1	33.50	20.00	-3.79	3.79	127.02	0.05	42.12	Vu < PhiVc/2	lot Req'd 9.6.	42.1	0.0 0.0
+1.20D+1.60L+0.50S+1.60H	1	34.05	20.00	-4.04	4.04	124.87	0.05	42.14	Vu < PhiVc/2	lot Req'd 9.6.	42.1	0.0 0.0
+1.20D+1.60L+0.50S+1.60H	1	34.60	20.00	-4.29	4.29	122.59	0.06	42.17	Vu < PhiVc/2	lot Req'd 9.6.	42.2	0.0 0.0
+1.20D+1.60L+0.50S+1.60H	1	35.15	20.00	-4.54	4.54	120.16	0.06	42.19	Vu < PhiVc/2	lot Req'd 9.6.	42.2	0.0 0.0
+1.20D+1.60L+0.50S+1.60H	1	35.70	20.00	-4.79	4.79	117.60	0.07	42.21	Vu < PhiVc/2	lot Req'd 9.6.	42.2	0.0 0.0
+1.20D+1.60L+0.50S+1.60H	1	36.25	20.00	-5.03	5.03	114.91	0.07	42.24	Vu < PhiVc/2	lot Req'd 9.6.	42.2	0.0 0.0
+1.20D+1.60L+0.50S+1.60H	1	36.80	20.00	-5.28	5.28	112.07	0.08	42.26	Vu < PhiVc/2	lot Req'd 9.6.	42.3	0.0 0.0
+1.20D+1.60L+0.50S+1.60H	1	37.34	20.00	-5.53	5.53	109.10	0.08	42.29	Vu < PhiVc/2	lot Req'd 9.6.	42.3	0.0 0.0
+1.20D+1.60L+0.50S+1.60H	1	37.89	20.00	-5.78	5.78	106.00	0.09	42.32	Vu < PhiVc/2	lot Req'd 9.6.	42.3	0.0 0.0
+1.20D+1.60L+0.50S+1.60H	1	38.44	20.00	-6.03	6.03	102.75	0.10	42.35	Vu < PhiVc/2	lot Req'd 9.6.	42.4	0.0 0.0
+1.20D+1.60L+0.50S+1.60H	1	38.99	20.00	-6.28	6.28	99.37	0.11	42.39	Vu < PhiVc/2	lot Req'd 9.6.	42.4	0.0 0.0
+1.20D+1.60L+0.50S+1.60H	1	39.54	20.00	-6.53	6.53	95.86	0.11	42.43	Vu < PhiVc/2	lot Req'd 9.6.	42.4	0.0 0.0
+1.20D+1.60L+0.50S+1.60H	1	40.09	20.00	-6.78	6.78	92.20	0.12	42.47	Vu < PhiVc/2	lot Req'd 9.6.	42.5	0.0 0.0
+1.20D+1.60L+0.50S+1.60H	1	40.64	20.00	-7.02	7.02	88.42	0.13	42.52	Vu < PhiVc/2	lot Req'd 9.6.	42.5	0.0 0.0
+1.20D+1.60L+0.50S+1.60H	1	41.19	20.00	-7.27	7.27	84.49	0.14	42.57	Vu < PhiVc/2	lot Req'd 9.6.	42.6	0.0 0.0
+1.20D+1.60L+0.50S+1.60H	1	41.74	20.00	-7.52	7.52	80.43	0.16	42.63	Vu < PhiVc/2	lot Req'd 9.6.	42.6	0.0 0.0
+1.20D+1.60L+0.50S+1.60H	1	42.29	20.00	-7.77	7.77	76.23	0.17	42.70	Vu < PhiVc/2	lot Req'd 9.6.	42.7	0.0 0.0
+1.20D+1.60L+0.50S+1.60H	1	42.84	20.00	-8.02	8.02	71.89	0.19	42.78	Vu < PhiVc/2	lot Req'd 9.6.	42.8	0.0 0.0
+1.20D+1.60L+0.50S+1.60H	1	43.39	20.00	-8.27	8.27	67.42	0.20	42.86	Vu < PhiVc/2	lot Req'd 9.6.	42.9	0.0 0.0
+1.20D+1.60L+0.50S+1.60H	1	43.93	20.00	-8.52	8.52	62.81	0.23	42.97	Vu < PhiVc/2	lot Req'd 9.6.	43.0	0.0 0.0
+1.20D+1.60L+0.50S+1.60H	1	44.48	20.00	-8.76	8.76	58.07	0.25	43.09	Vu < PhiVc/2	lot Req'd 9.6.	43.1	0.0 0.0
+1.20D+1.60L+0.50S+1.60H	1	45.03	20.00	-9.01	9.01	53.19	0.28	43.24	Vu < PhiVc/2	lot Req'd 9.6.	43.2	0.0 0.0
+1.20D+1.60L+0.50S+1.60H	1	45.58	20.00	-9.26	9.26	48.17	0.32	43.42	Vu < PhiVc/2	lot Req'd 9.6.	43.4	0.0 0.0
+1.20D+1.60L+0.50S+1.60H	1	46.13	20.00	-9.51	9.51	43.01	0.37	43.65	Vu < PhiVc/2	lot Req'd 9.6.	43.6	0.0 0.0
+1.20D+1.60L+0.50S+1.60H	1	46.68	20.00	-9.76	9.76	37.72	0.43	43.95	Vu < PhiVc/2	lot Req'd 9.6.	43.9	0.0 0.0
+1.20D+1.60L+0.50S+1.60H	1	47.23	20.00	-10.01	10.01	32.29	0.52	44.36	Vu < PhiVc/2	lot Req'd 9.6.	44.4	0.0 0.0
+1.20D+1.60L+0.50S+1.60H	1	47.78	20.00	-10.26	10.26	26.73	0.64	44.94	Vu < PhiVc/2	lot Req'd 9.6.	44.9	0.0 0.0
+1.20D+1.60L+0.50S+1.60H	1	48.33	20.00	-10.51	10.51	21.03	0.83	45.87	Vu < PhiVc/2	lot Req'd 9.6.	45.9	0.0 0.0
+1.20D+1.60L+0.50S+1.60H	1	48.88	20.00	-10.75	10.75	15.19	1.00	46.67	Vu < PhiVc/2	lot Req'd 9.6.	46.7	0.0 0.0
+1.20D+1.60L+0.50S+1.60H	1	49.43	20.00	-11.00	11.00	9.22	1.00	46.67	Vu < PhiVc/2	lot Req'd 9.6.	46.7	0.0 0.0
+1.20D+1.60L+0.50S+1.60H	1	49.98	20.00	-11.25	11.25	3.11	1.00	46.67	Vu < PhiVc/2	lot Req'd 9.6.	46.7	0.0 0.0

Maximum Forces & Stresses for Load Combinations

Load Combination Segment	Span #	Location (ft) along Beam	Bending Stress Results (k-ft)		
			Mu : Max	Phi*Mnx	Stress Ratio
MAXimum BENDING Envelope					
Span # 1	1	50.250	142.90	165.90	0.86
+1.40D+1.60H	1	50.250	96.02	165.90	0.58
+1.20D+0.50Lr+1.60L+1.60H	1	50.250	142.90	165.90	0.86



CLIMATE-DECK™
TILT-UP FORMS
50' SPAN DESIGN

(4.2) @ 24" x 48" x 144"

STRUCTURAL DETAILS

Project number	CD2448144TU	SD-102
Date	06.12.2023	
Drawn by	Author	
Checked by	Checker	
		Scale

Concrete Beam

Lic. # : KW-06014113

File: Concrete floor design.ec6
 Software copyright ENERCALC, INC. 1983-2020, Build:12.20.8.2
 Site Serve LLC

DESCRIPTION: typ 50' span 3" slab square shape

Load Combination Segment	Span #	Location (ft) along Beam	Bending Stress Results (k-ft)		
			Mu : Max	Phi*Mnx	Stress Ratio
+1.20D+1.60L+0.50S+1.60H Span # 1	1	50.250	142.90	165.90	0.86
+1.20D+1.60Lr+L+1.60H Span # 1	1	50.250	120.18	165.90	0.72
+1.20D+1.60Lr+0.50W+1.60H Span # 1	1	50.250	82.30	165.90	0.50
+1.20D+L+1.60S+1.60H Span # 1	1	50.250	120.18	165.90	0.72
+1.20D+1.60S+0.50W+1.60H Span # 1	1	50.250	82.30	165.90	0.50
+1.20D+0.50Lr+L+W+1.60H Span # 1	1	50.250	120.18	165.90	0.72
+1.20D+L+0.50S+W+1.60H Span # 1	1	50.250	120.18	165.90	0.72
+0.90D+W+1.60H Span # 1	1	50.250	61.73	165.90	0.37
+1.20D+L+0.20S+E+1.60H Span # 1	1	50.250	120.18	165.90	0.72
+0.90D+E+0.90H Span # 1	1	50.250	61.73	165.90	0.37

Overall Maximum Deflections

Load Combination	Span	Max. "-" Defl (in)	Location in Span (ft)	Load Combination	Max. "+" Defl (in)	Location in Span (ft)
+D+L+H	1	1.8941	25.125		0.0000	0.000



CLIMATE-DECK™
 TILT-UP FORMS
 50' SPAN DESIGN

(4.2) @ 24" x 48" x 144"

STRUCTURAL DETAILS

Project number	CD2448144TU	SD-103
Date	06.12.2023	
Drawn by	Author	Scale
Checked by	Checker	