



# PRODUCT GUIDE

BOLD AND BRILLIANT

ALUMINUM + ARCHITECTURE







# TABLE OF CONTENTS

5	OUR JOURNEY
6	OUR LEGACY AND MILESTONES
7	OUR MISSION
8	CRAFTING QUALITY
9	CERTIFICATES AND TESTS
10-11	COLOR PRODUCT GUIDE

## SLIDING DOORS: 12-25

14-15	MOREVIEW S
16-17	MOREVIEW
18-19	PERFORMANCE LIFT'N'SLIDE
20-21	PERFORMANCE PRIMEVIEW
22-23	BI-FOLD TM 77
24-25	ECO DP SLIDE

## WINDOWS: 26-37

28-29	MOREVIEW
30-31	INDUSTRIAL
32-33	PASSIVE TM 102
34-35	PERFORMANCE TM 77
36-37	ECO TM 62

## DOORS: 38-51

40-41	MOREVIEW
42-43	PASSIVE TM 102
44-45	PERFORMANCE TM 77 PRESTIGE
46-47	PERFORMANCE TM 77
48-49	ECO TM 62
50-51	INTERIOR PBI 50

## CURTAIN WALLS: 52-59

54-55	FA 50N DESIGN LINE
56-57	FA 50N SMOOTH LINE
58-59	PANORAMIC CW WINDOW

## ADD-ONS: 60-77

62-63	SUNSHADES AND LOUVERS
64-65	JULIET BALCONY
66-67	VERTILINE
68-69	INSECTS SCREEN
70-71	GLASS RAILINGS
72-73	LED PROFILE
74-75	ECLIPSE 33
76-77	LINEAR DRAINAGE





# OUR JOURNEY

Our history is deeply rooted in family values and began in 1990. At the heart of our company lies a commitment to transforming architectural dreams into tangible structures.

## 1.

### **From our humble beginnings in a small garage in Poland,**

We have grown through our unwavering commitment to client satisfaction, rigorous research, and dedication to crafting superior products. This journey has established us as frontrunners in the European market of aluminum windows, doors, and facades.

## 3.

### **Enduring Commitment of Our U.S.-Based Entity:**

Delivering Timeless Products with Unmatched Technical and Maintenance Support Spanning over three decades in the industry, our brand has become synonymous with luxury, exceptional style, and a steadfast commitment to quality. Each product we create is a testament to precision and meticulous attention to detail, designed to align perfectly with your vision.

Our state-of-the-art manufacturing facility, effective warehousing strategies, and unwavering dedication to timely deliveries reflect our pursuit of excellence in every aspect of our business.



## 2.

### **We Expanded Beyond Europe with 30-year experience:**

In a significant strategic step, CEO Karolina Mzyk-Callias relocated to the United States, opening a new and exciting chapter in our journey. This move introduced our high-quality products to a dynamic new market. Today, our presence stands as a testament to the fusion of European design elegance with American innovative spirit.



## 4.

### **Choosing us is more than just a product choice;**

It's entering a partnership rooted in trust, superior craftsmanship, and a pledge to exceed your expectations.



---

# OUR LEGACY AND MILESTONES

## A LEGACY OF INNOVATION AND GROWTH

YAWAL's journey began in September 1990, marking the start of a transformative era in aluminum joinery. We were pioneers in utilizing thermally insulated profiles from Western Europe, setting a new standard in the industry.

- EXPANSIONS AND TRANSFORMATIONS
- COMMITMENT TO SUSTAINABILITY
- INNOVATIVE BREAKTHROUGHS
- ADAPTING TO MARKET NEEDS

YAWAL's evolution features expansive growth, the introduction of the cutting-edge Moreview system, a strategic upscaling of production to meet market needs, and an enduring pledge to environmental stewardship.



# OUR MISSION

## MISSION

WE PROVIDE THE HIGHEST QUALITY EUROPEAN ALUMINUM SYSTEMS WITH THE BEST, DEDICATED CUSTOMER SERVICES FOR THE AMERICAN MARKET.

## VALUES:



EXPERIENCE



CUSTOMER ORIENTATION



COMMITMENT



PROFESSIONALISM



INNOVATION



ECOLOGY





# CRAFTING QUALITY

## STEP BY STEP

AT OUR COMPANY, SUPERIOR CUSTOMER SERVICE IS AT THE CORE OF EVERYTHING WE DO. HERE'S A SIMPLE OVERVIEW OF THE PROCEDURES WE FOLLOW TO CATER TO YOUR NEEDS:

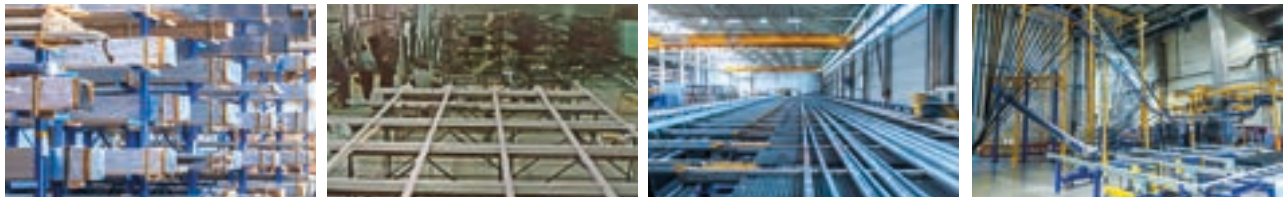

### 1. CLIENT CONSULTATION

We begin with an in-depth consultation with clients to understand their specific needs and preferences.

### 2. ESTIMATION

Following the consultation, we provide accurate and tailored estimations to align with your specifications.

### 3. EXTRUSION

Transitioning to the extrusion phase, we mold aluminum into precise profiles for windows and doors.

### 4. THERMAL INSULATION

Our attention then gravitates towards embedding advanced thermal insulation for top-tier energy efficiency.

### 5. VARNISHING

With the structure in place, protective and aesthetic coatings are applied to strike a balance between longevity and style.

### 6. FABRICATION OF WINDOWS

Meticulous assembly of window units follows.

### 7. GLAZING

Incorporating the right glass elements, we ensure clarity and robust functionality.

### 8. PACKAGING AND DELIVERY

Concluding our process, our products are securely packaged and delivered, reaching you in impeccable condition.

### 9. INSTALLATION SUPPORT AND TRAINING

We provide on-site training and support during installation, ensuring seamless integration of our products and empowering clients with essential knowledge.

### 10. ANNUAL MAINTENANCE CHECK

Our service extends to annual maintenance checks, offering post-sale verification to maintain the optimal performance and longevity of our products.

We are dedicated to exceeding your expectations with every order and interaction.

We anticipate a fruitful collaboration on future projects, and we hope to be your first choice time and again.



# CERTIFICATES AND TESTS

## ISO 9001: 2015 COMPLIANT:

---

Guiding our design, production, and distribution to uphold the highest standards

## RECOGNIZED CERTIFICATIONS:

---

Proudly accredited by AAMA, NFRC, and Passive House, with hurricane certification in progress.

## ENVIRONMENTAL STEWARDSHIP:

---

Adhering to the ISO 14001:2004 Environmental Management System, reflecting our dedication to sustainability.

## QUALICOAT LICENSED:

---

Including Seaside, guarantees consistent excellence in our aluminum powder varnishing.



# COLOR PRODUCT GUIDE

## STANDARD COLORS



RAL 9005 MATT

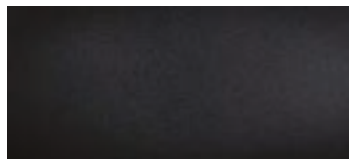

RAL 7021 MATT



RAL 7021 STRUCTURE

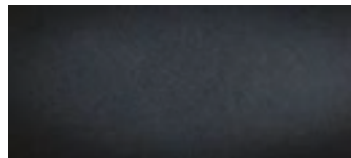

RAL 7016 MATT



RAL 7016 STRUCTURE

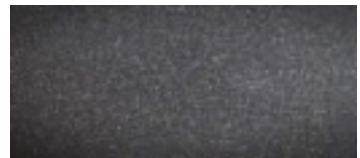

RAL DB703 MATT



RAL 9007 MATT



RAL 9006 MATT



RAL 9016 MATT

## SPECIAL COLORS



CORTEN STEEL  
1037029

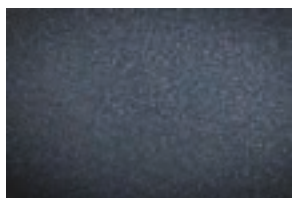

RAL 7016 METALIC  
029/71334

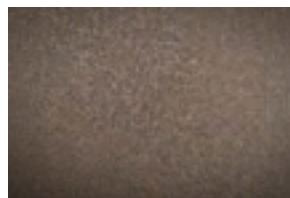

SEPIA BROWN  
029/69740

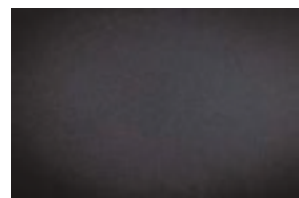

TWILIGHT  
1226709

The colors shown above are for illustrative purposes only.

In the catalog presented only a part of the available color palette, for full color pattern inquire at [support@yawalusa.com](mailto:support@yawalusa.com)

# COLOR PRODUCT GUIDE

## WOODGRAIN COLORS



LIGHT OAK  
916 1402 03



PINE WITHOUT KNOTS  
716 1501 01



PINE  
451 2103 01



WALNUT  
733 1829 11



CHERRY  
716 1401 01



CHERRIES



OAK  
797 2305 17



DARK WALNUT  
755 2301 03



DARK CHERRY  
75 1403 01



WINCHESTER  
682 1403 01



GOLDEN OAK  
739 2301 02



MAHOGANY  
742 1704 02

The colors shown above are for illustrative purposes only.

In the catalog presented only a part of the available color palette, for full color pattern inquire at [support@yawalusa.com](mailto:support@yawalusa.com)

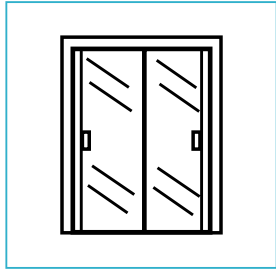

# SLIDING DOORS

EXPERIENCE THE ELEGANCE OF OUR SLIDING & FOLDING DOORS, BLENDING FUNCTIONALITY WITH DESIGN TO CREATE BRIGHT, EXPANSIVE SPACES. EACH PIECE REFLECTS A COMMITMENT TO COMFORT AND MODERN INNOVATION.







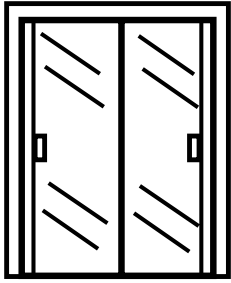

SLIDING DOORS

# MOREVIEW S



DISCOVER THE BEAUTY OF THE MOREVIEW S, WHERE BOLD DESIGN MEETS CRYSTAL-CLEAR VIEWS. DESIGNED FOR EVERYDAY LIVING, ENJOY THE GREAT OUTDOORS FROM THE COMFORT OF YOUR HOME WITH THESE DOORS.

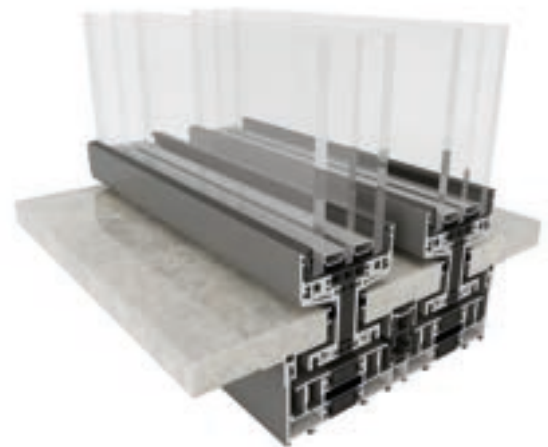



### MOREVIEW S DOUBLE TRACK

#### INVISIBLE TRACK SYSTEM:

Invisible track system is an ultra-modern solution that allows for an almost complete blurring of the boundary between the interior and exterior. All structural elements are hidden under the floor. The user sees only narrow, gaps. This solution enables virtually unlimited possibilities for arranging flooring at the junction of the home's interior and the external environment, such as a terrace.

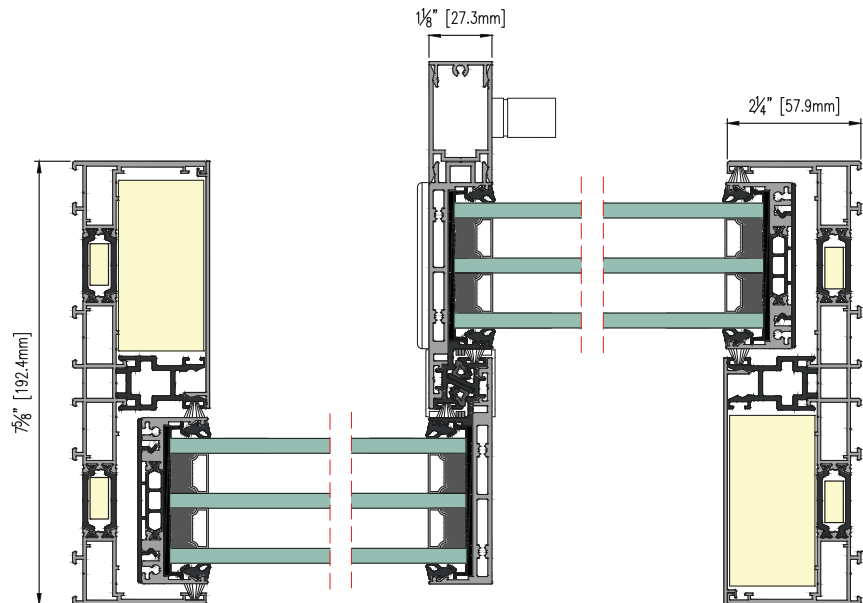
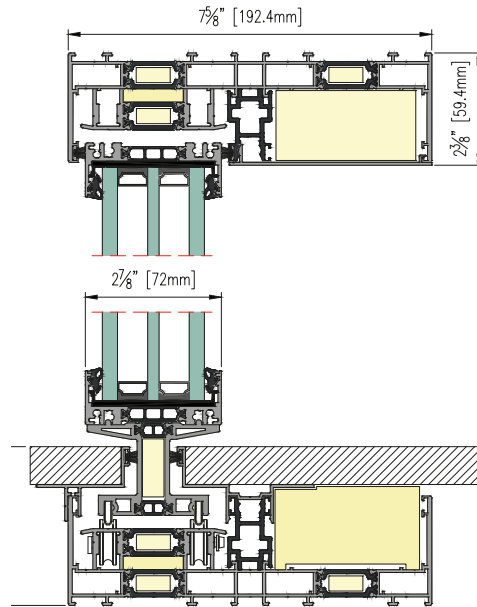

#### FEATURES:

- Invisible track system
- Extremely high Visible Light Transmittance (VLT) with a minimal frame profile, offering a 98% unobstructed view
- 1-inch minimal interlock visible width
- Track frame profile seamlessly blended with the floor
- Motorized panels compatible with iOS and Android devices
- Fully integrated linear drainage system
- Capability for a full 90-degree corner opening
- Suitable for pocket installation
- Integrated insect screen



#### TECHNICAL PARAMETERS:

- Water Tightness: **5 psf**
- Designed Pressure: **LC 40 psf**
- Thermal Insulation: **From 0.12 Btu/hft<sup>2</sup>F**
- Acoustic Insulation: **STC up to 42 dB**
- Maximum Sash Weight: **3300 lbs (1500kg)**
- Maximum Sash Height: **16 ft (5m)**
- Maximum Sash Width: **21 ft (6,5m)**
- Glazing: **Double and triple**



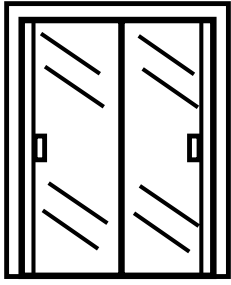

SLIDING DOORS

# MOREVIEW



WORLD OF MOREVIEW, WHERE LIGHT AND SPACE UNITE IN STUNNING HARMONY. AN ARCHITECTURAL JOURNEY THAT CONNECTS YOU WITH THE GREAT OUTDOORS, FEATURING UP TO 98% TRANSPARENCY FOR A FLAWLESS FUSION OF INDOOR AND OUTDOOR LIVING.

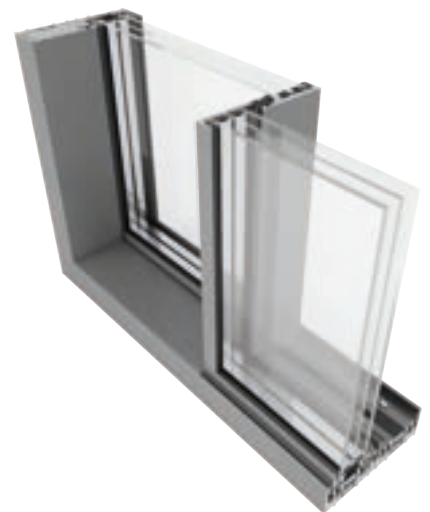



## MOREVIEW DOUBLE TRACK

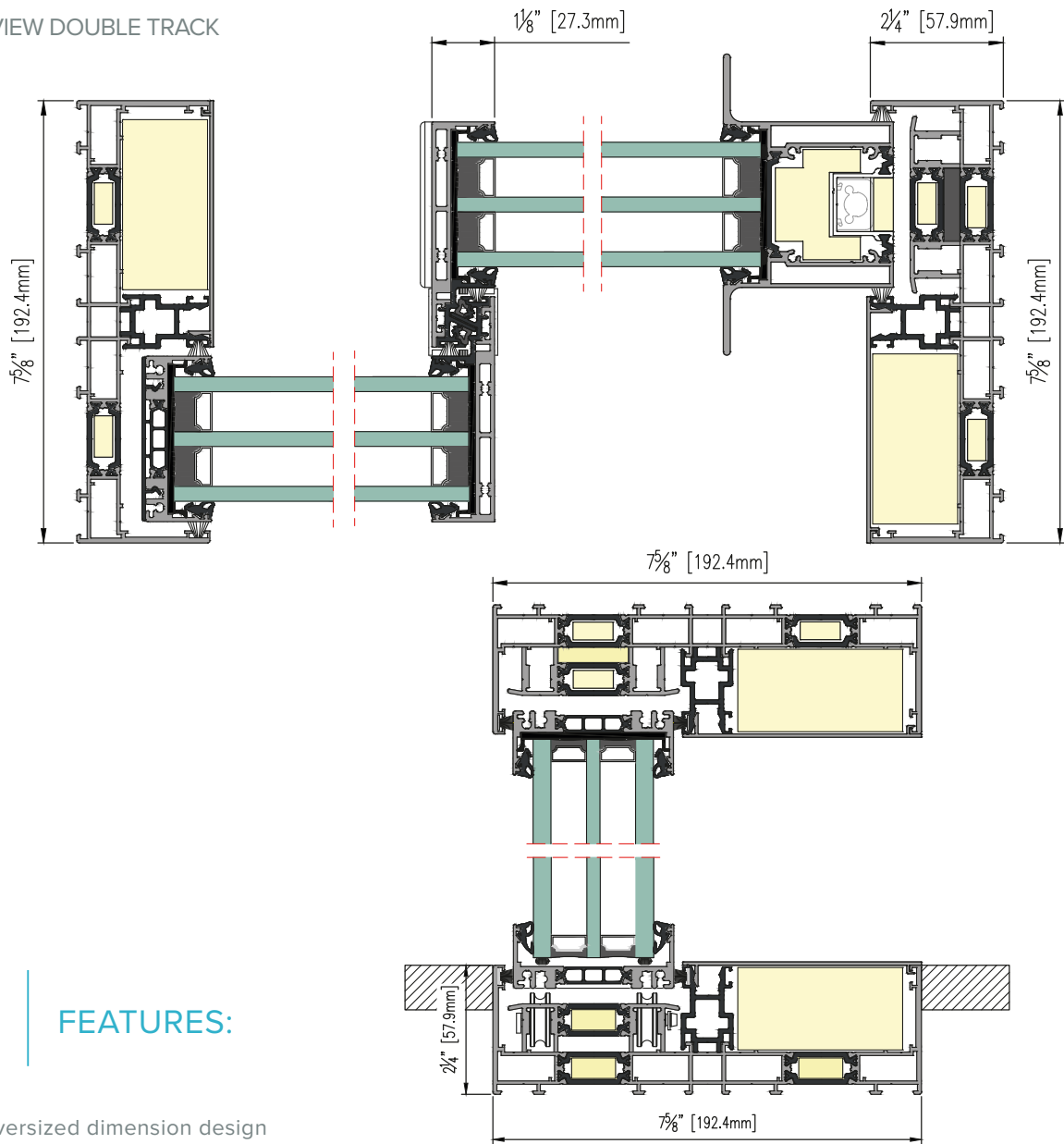

### FEATURES:

- Oversized dimension design with extremely large panel sizes
- Minimal frame profile offering exceptionally high Visible Light Transmittance (VLT), with a 98% non-obstructed view
- 1-inch minimal interlock visible width
- High resistance to wind loads
- Motorized panels compatible with iOS and Android devices
- Fully integrated linear drainage system
- Capability for a full 90-degree corner opening
- Suitable for pocket installation
- Integrated insect screen
- Static mullion supports for added stability
- Fixed glazing featuring an any-angle glass corner for versatile design options
- Easy maintenance without the need for panel removal



### TECHNICAL PARAMETERS:

- Water Tightness: **5 psf**
- Designed Pressure: **LC 40 psf**
- Thermal Insulation: **From 0.12 Btu/hft<sup>2</sup>F**
- Acoustic Insulation: **STC up to 42 dB**
- Maximum Sash Weight: **3300 lbs (1500kg)**
- Maximum Sash Height: **16 ft (5m)**
- Maximum Sash Width: **13 ft (4m)**
- Maximum Panel Width: **21 ft (6,5m)**
- Glazing: **Double and triple**



SLIDING DOORS

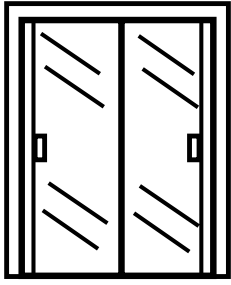

SLIDING DOORS

# PERFORMANCE LIFT'N'SLIDE



STEP INTO A BLEND OF STYLE AND CONVENIENCE WITH OUR PERFORMANCE LIFT'N'SLIDE SYSTEM. THIS DOOR GOES BEYOND THE USUAL, FEATURING EXTENSIVE GLAZING THAT OPENS UP YOUR WORLD TO AN EXTRAORDINARY DISPLAY OF LIGHT AND VIEWS.



PERFORMANCE LIFT'N'SLIDE  
MONORAIL WITH INSECT SCREEN

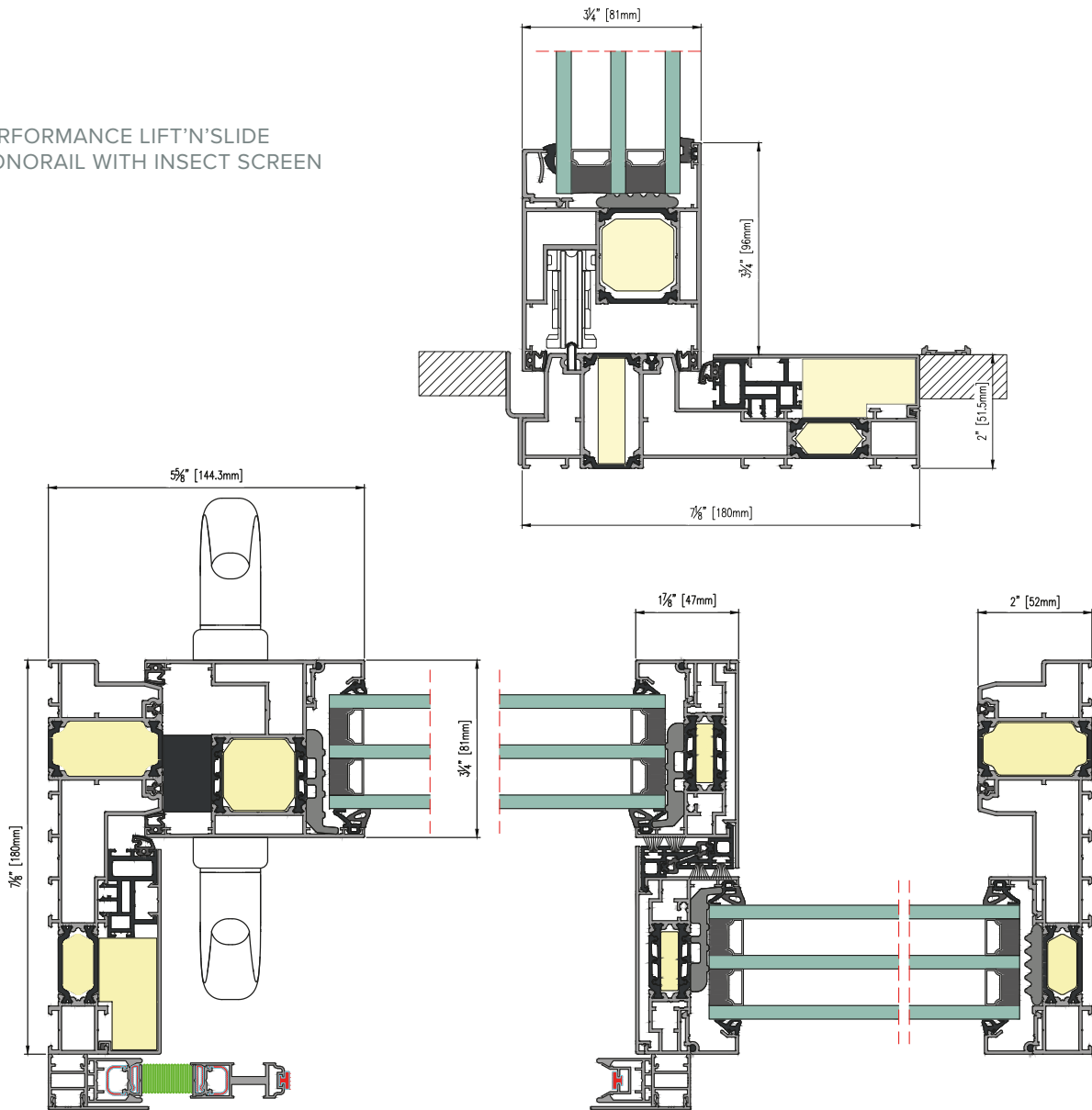

SLIDING DOORS



FEATURES:

- Expansive glazing for enhanced light and views
- Advanced gasketing and Lift'n'Slide hardware for tightness
- 2" interlock for structural integrity
- Low-profile threshold design
- Automated systems with Bluetooth, eye-scan, and fingerprint access
- Customizable frame finishes, including wood-like options
- Motorized panels compatible with iOS and Android devices
- Integrated linear drainage system



TECHNICAL PARAMETERS:

- Water Tightness: **12 psf**
- Designed Pressure: **CW 60 psf**
- Thermal Insulation: **From 0.12 Btu/hft²F**
- Acoustic Insulation: **STC up to 47 dB**
- Maximum Panel Weight: **1000 lbs (450 kg)**
- Maximum Panel Height: **11 ft (3,4m)**
- Maximum Panel Width: **11 ft (3,4m)**
- Glazing: **Double and triple**

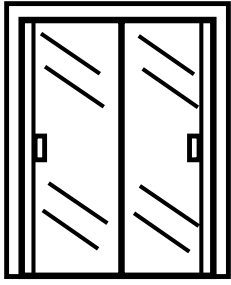

SLIDING DOORS

# PERFORMANCE PRIMEVIEW



ENHANCE YOUR EXPERIENCE WITH OUR PRIMEVIEW SOLUTION, AN UPGRADE WITHIN THE PERFORMANCE LINE. THIS VARIANT REDEFINES MINIMALISM WITH A MIRRORED DESIGN THAT BLENDS IN WITH ITS SURROUNDINGS, OFFERING A SEAMLESS AND VISUALLY STRIKING EXPERIENCE.





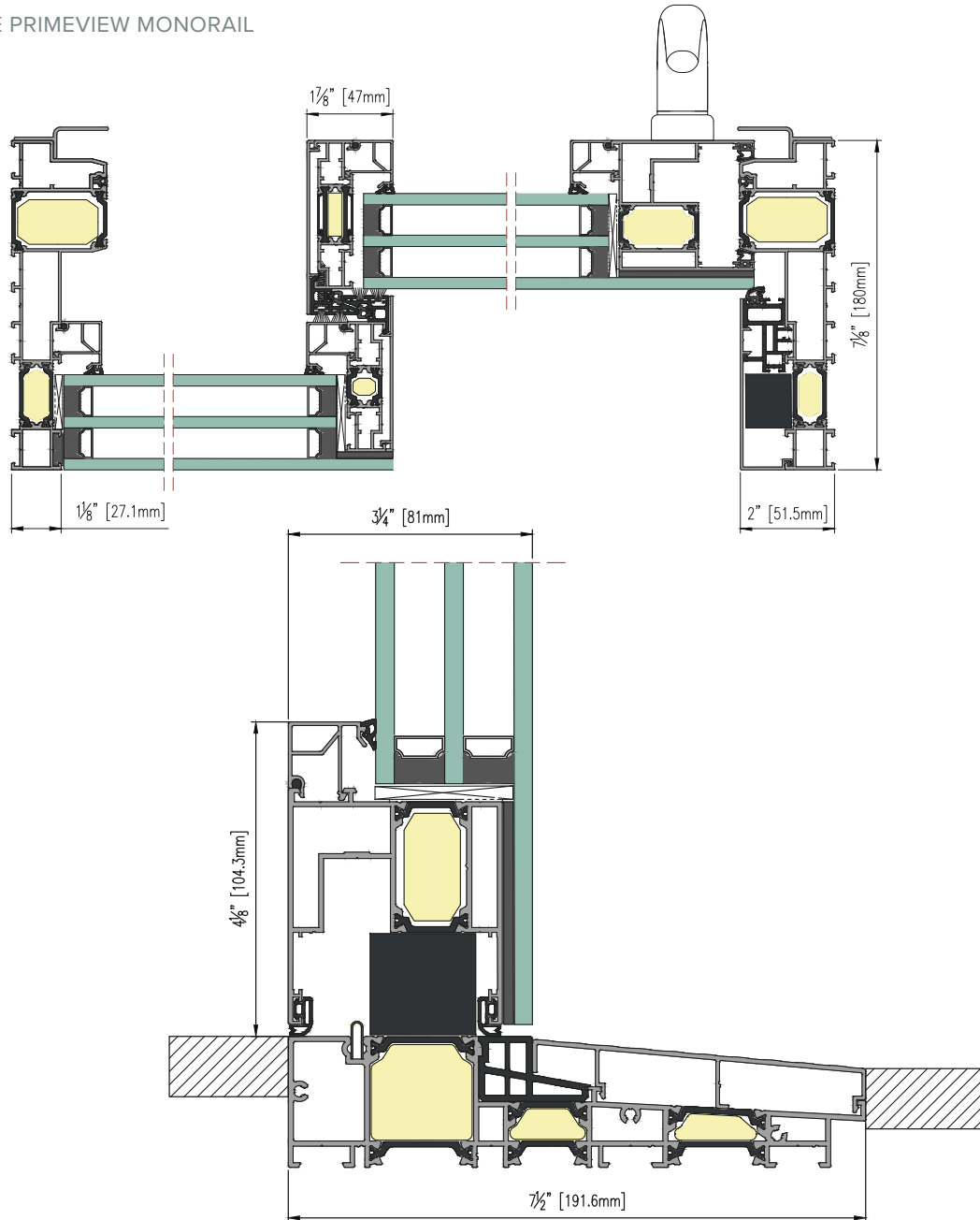

FEATURES:

- Full glass, no visible profile slider, blending with wall structure
- Hardware invisible from outside
- Full glass house architecture
- Low-profile threshold design
- 2" interlock for structural integrity
- Motorized panels, iOS/Android compatible
- Advanced automation with Bluetooth, eye-scan, and fingerprint access
- Integrated linear drainage system



TECHNICAL PARAMETERS:

- Water Tightness: **12 psf**
- Designed Pressure: **CW 60 psf**
- Thermal Insulation: **From 0.12 Btu/hft<sup>2</sup>F**
- Acoustic Insulation: **STC up to 47 dB**
- Maximum Panel Weight: **1000 lbs (450kg)**
- Maximum Panel Height: **11 ft (3,4m)**
- Maximum Panel Width: **11 ft (3,4m)**
- Glazing: **Double and triple**

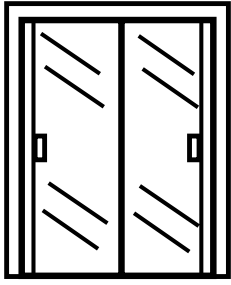

SLIDING DOORS

# BI-FOLD TM 77



BI-FOLD DOORS OFFER FLEXIBLE, MULTI-PANEL DESIGNS FOR DIVERSE CONFIGURATIONS, OPTIMIZING SPACE UTILIZATION AND BLENDING INDOOR-OUTDOOR LIVING WITH STYLISH EFFICIENCY.





BI-FOLD TM 77 OUTWARD OPENED

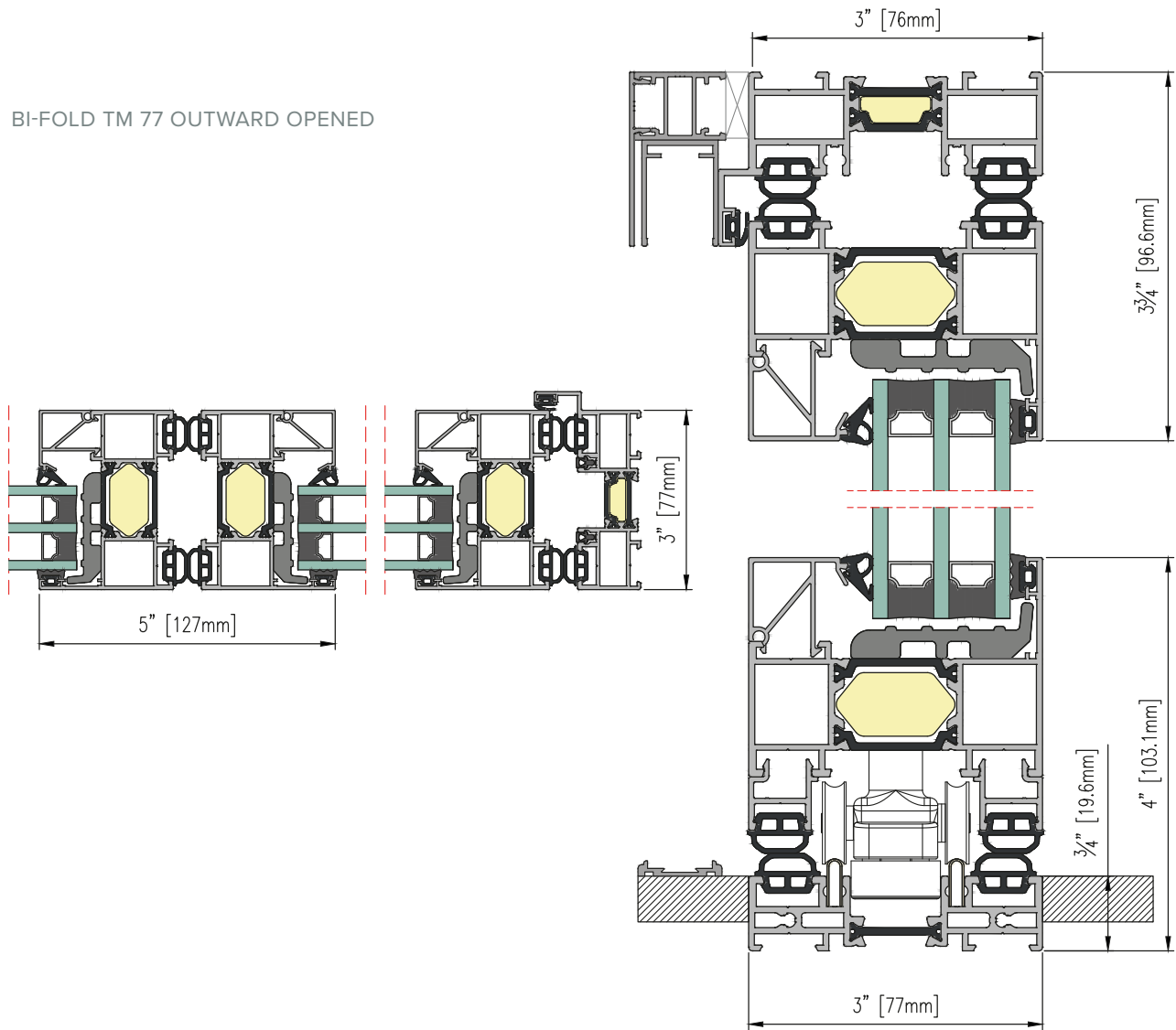

FEATURES:

- Best-in-class panel height
- Multiple panel options for various opening sizes
- Initial panel with pivot feature for easy access and folding
- Options for low thresholds
- Configurations include inward/outward and left/right opening
- Compact folding design for maximized open space
- Enhanced thermal efficiency
- Broad glazing surfaces for increased natural light



TECHNICAL PARAMETERS:

- Water Tightness: **5 psf**
- Designed Pressure: **LC 35 psf**
- Thermal Insulation: **From 0.15 Btu/hft<sup>2</sup>F**
- Acoustic Insulation: **STC up to 42 dB**
- Maximum Panel Weight: **440 lbs (200 kg)**
- Maximum Panel Height: **12 ft (3,5m)**
- Maximum Panel Width: **4 ft (1,2m)**
- Glazing: **Double and triple**



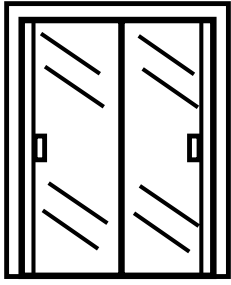

SLIDING DOORS

# ECO DP SLIDE



ELEVATE YOUR HOME'S AMBIANCE WITH OUR ECO DP SLIDE DOORS. THESE DOORS BLEND THE TIMELESS APPEAL OF SLIDING DOOR AESTHETICS WITH MODERN FUNCTIONALITY, SEAMLESSLY FITTING INTO A VARIETY OF RESIDENTIAL & COMMERCIAL ARCHITECTURAL STYLES.



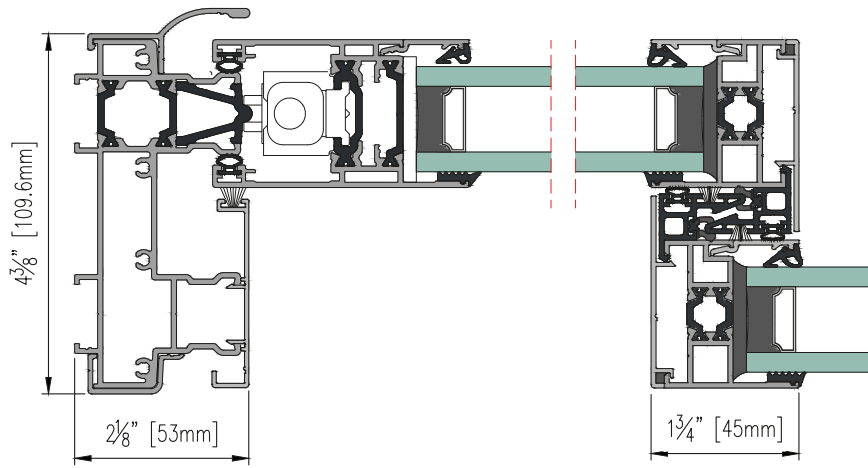

ECO DP SLIDE WITH NARROW MULLION

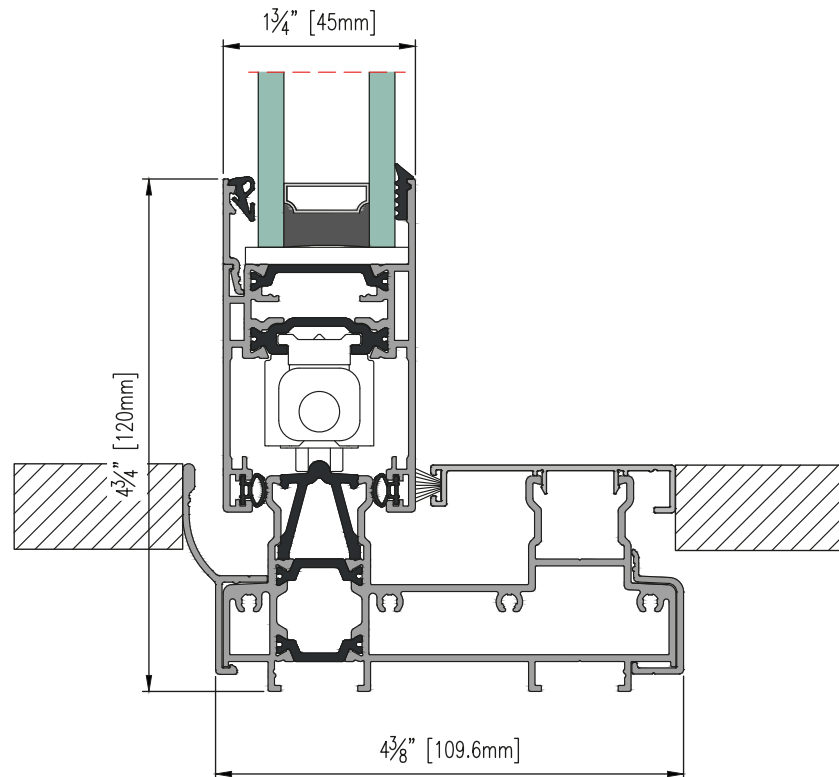

FEATURES:

- Cost-efficient for light commercial and volume residential applications
- Options for Lift'n'Slide and sliding hardware
- High thermal performance
- Suitable for multi-unit residential construction
- Broad glazing surfaces to enhance natural light



TECHNICAL PARAMETERS:

- Water Tightness: **7.5 psf**
- Designed Pressure: **LC 50 psf**
- Thermal Insulation: **From 0.23 Btu/hft<sup>2</sup>F**
- Acoustic Insulation: **STC up to 48 dB**
- Maximum Panel Weight: **440 lbs (200 kg)**
- Maximum Panel Height: **8 ft (2,44m)**
- Maximum Panel Width: **4 ft (1,22m)**
- Glazing: **Double**

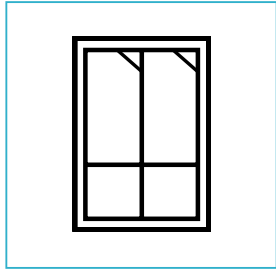

# WINDOWS

EXPLORE A FUSION OF STYLE AND ECO-CONSCIOUS DESIGNS WITH OUR WINDOWS COLLECTION. EACH WINDOW SHOWCASES A PERFECT BALANCE OF SCENIC ELEGANCE AND ENERGY EFFICIENCY. ENJOY BREATHTAKING VIEWS WHILE BENEFITING FROM TOP-NOTCH THERMAL AND ACOUSTIC PERFORMANCE, ALL DELIVERED WITH A STRONG COMMITMENT TO ENVIRONMENTAL RESPONSIBILITY.









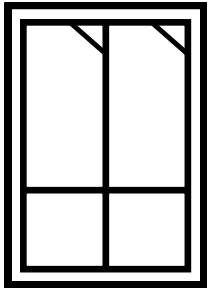

WINDOWS

# MOREVIEW WINDOW



ENTER THE REALM OF MINIMALISM AND CLARITY WITH THE MOREVIEW WINDOW SYSTEM. THIS INNOVATIVE DESIGN REDEFINES MODERN WINDOWS, BLENDING STREAMLINED AESTHETICS WITH FUNCTIONAL ADVANCEMENT. MOREVIEW OPENS UP VAST VIEWS AND INTEGRATES SUBTLY WITH CONTEMPORARY ARCHITECTURE, MAKING IT A TRANSFORMATIVE CHOICE.



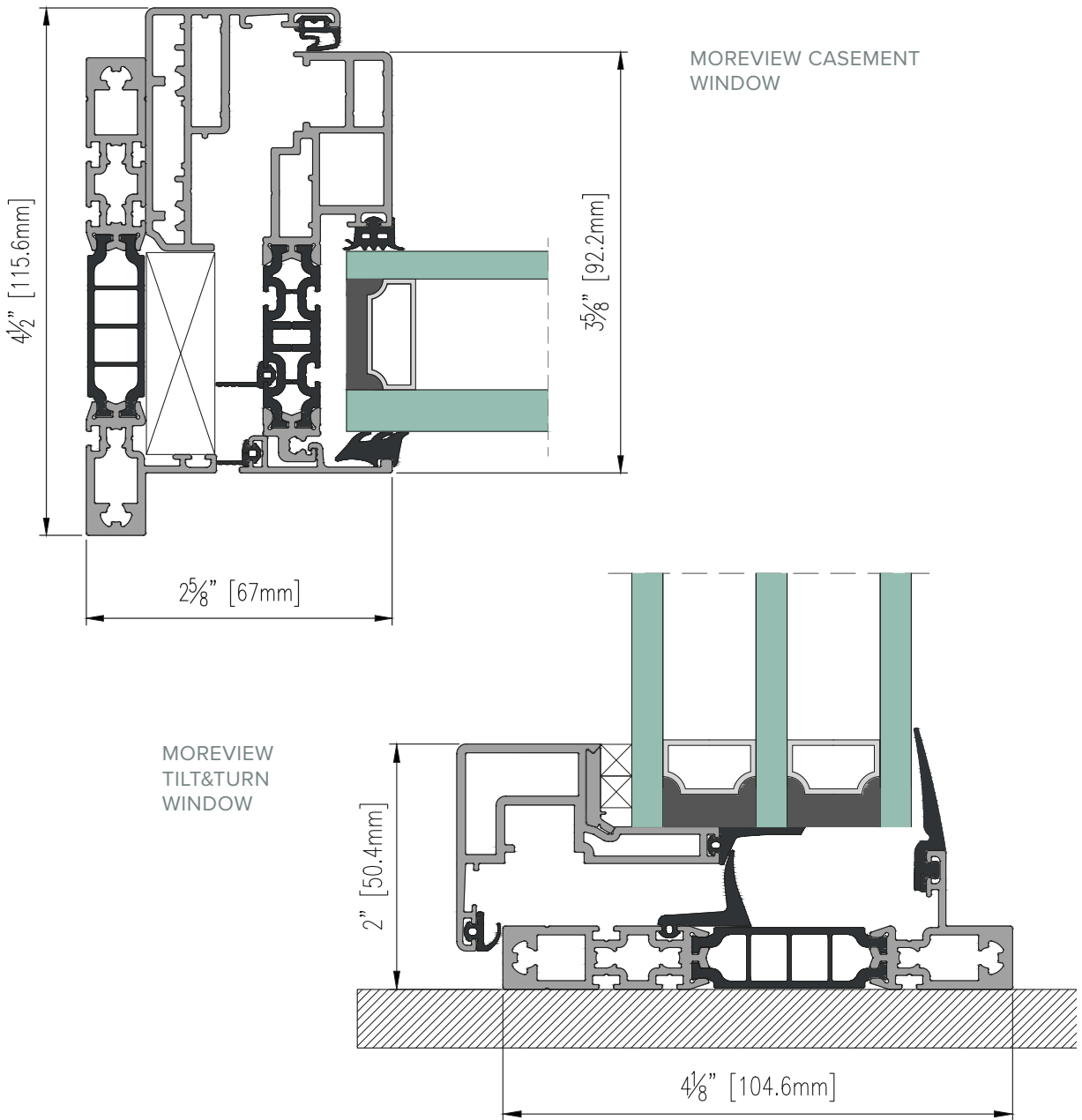

### FEATURES:

- Minimal frames and panel profiles
- Alternative to steel profiles
- Beveled glazing stop and SDL
- Visible width minimized to 2 inches (50mm)
- Super slim system, capable of fully replacing steel systems
- Modern design



### TECHNICAL PARAMETERS:

- Water Tightness: **12psf**
- Designed Pressure: **CW 55psf**
- Thermal Insulation: **From 0.17 Btu/hft<sup>2</sup>F**
- Acoustic Insulation: **STC up to 48 dB**
- Maximum Panel Weight: **330LB**
- Maximum Panel Height: **9 ft (2,7m)**
- Maximum Panel Width: **5 ft (1,5m)**
- Glazing: **Double and triple**



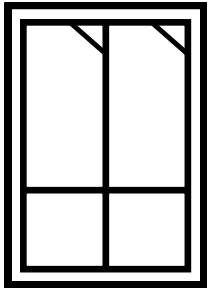

WINDOWS

# INDUSTRIAL



OUR INDUSTRIAL WINDOWS OFFER A MODERN, ELEGANT CHARM. THE DESIGN OF THIS SYSTEM ENHANCES SPACES WITH MAXIMUM DAYLIGHT, ALIGNING WITH MODERN ARCHITECTURAL TRENDS. EXPERIENCE LIVING AREAS TRANSFORMED BY ABUNDANT NATURAL LIGHT, ELEVATING YOUR EVERYDAY.



INDUSTRIAL  
SLIM STYLE  
FIXED WINDOW

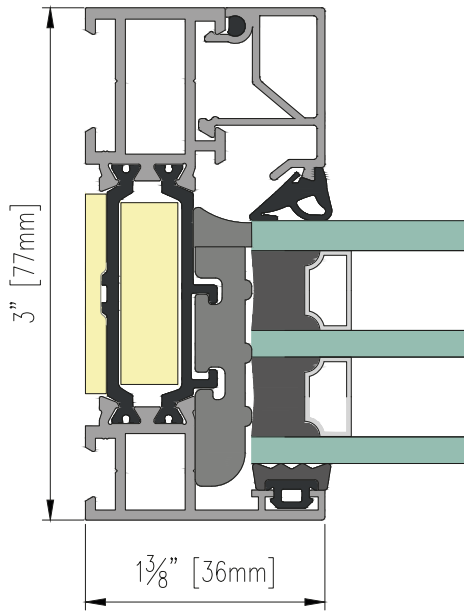

INDUSTRIAL  
SLIM STYLE  
TILT&TURN  
WINDOW

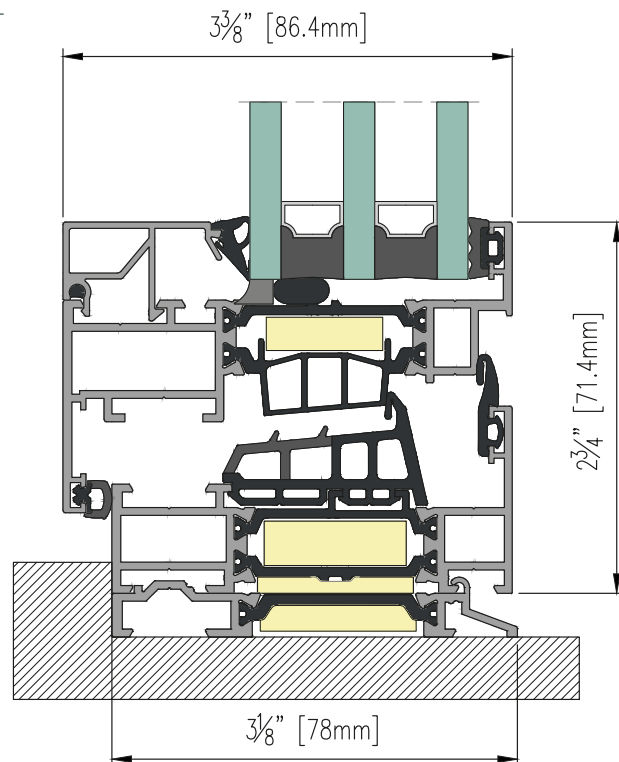

WINDOWS

ONE SYSTEM THREE DIFFERENT STYLES:

SLIM



STEEL



CUBIC



## FEATURES:

- Three industrial profile styles
- Variety of SDL (Simulated Divided Lite) and TDL (True Divided Lite) options
- Narrow sidelines, slim profile design
- Options for curved shapes
- Adaptive designs for windows and balcony doors, supporting multiple threshold types
- Hidden gravitational drainage with profile-driven condensate diversion
- Fully compatible with other Yawal systems
- Minimal visible width of 2.75" inches (71mm)
- Broad glazing surfaces for enhanced natural light



## TECHNICAL PARAMETERS:

- Water Tightness: **12 psf**
- Designed Pressure: **CW 65 psf**
- Thermal Insulation: **From 0.13 Btu/hft²F**
- Acoustic Insulation: **STC up to 39-44 dB**
- Maximum Panel Weight: **660 lbs (300 kg)**
- Maximum Panel Height: **10 ft (3m)**
- Maximum Panel Width: **5 ft (1,5m)**
- Glazing: **Double and triple**

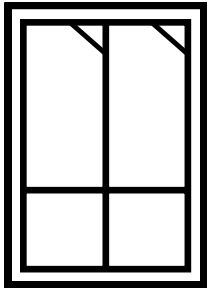

WINDOWS

# PASSIVE TM 102



THE PASSIVE WINDOW EXEMPLIFIES CUTTING-EDGE, ENERGY-EFFICIENT CONSTRUCTION. TAILORED FOR AMBITIOUS ARCHITECTURAL PROJECTS, IT PROVIDES EXCEPTIONAL THERMAL INSULATION AND VERSATILE GLAZING OPTIONS, CATERING TO ECO-CONSCIOUS, LARGE-SCALE DEVELOPMENTS.







PASSIVE TM 102  
TILT&TURN WINDOW  
WITH INSECT SCREEN

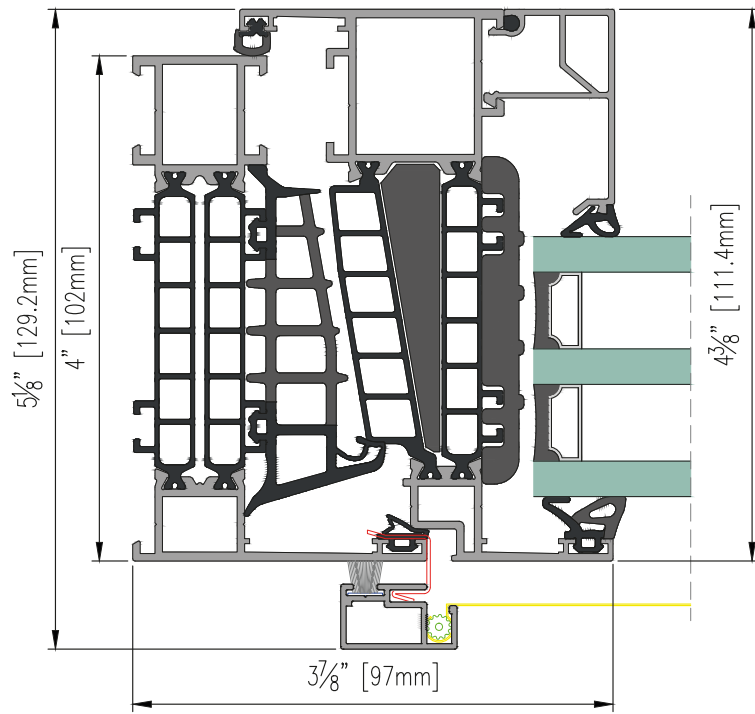
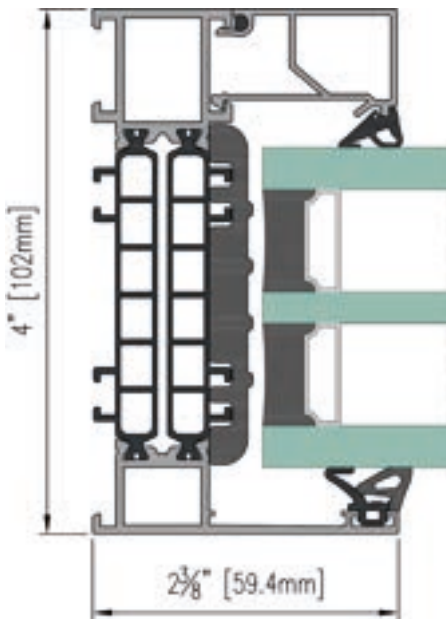

PASSIVE TM 102  
FIXED WINDOW



WINDOWS



## FEATURES:

- PHIUS certified
- Superior thermal performance
- Suitable for passive buildings and net-zero energy applications
- Supports up to 4-pane glazing configurations
- Advanced acoustic insulation
- Ideal for extensive structural designs
- Broad glazing surfaces for enhanced natural light



## TECHNICAL PARAMETERS:

- Water Tightness: **15 psf**
- Designed Pressure: **CW 75 psf**
- Thermal Insulation: **From 0.08 Btu/hft<sup>2</sup>F**
- Acoustic Insulation: **STC up to 48 dB**
- Maximum Panel Weight: **660 lbs (300 kg)**
- Maximum Panel Height: **10 ft (3m)**
- Maximum Panel Width: **5 ft (1,5m)**
- Glazing: **Double and triple**

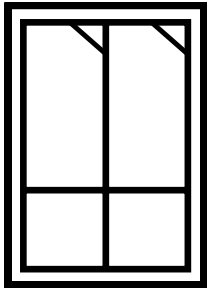

WINDOWS

# PERFORMANCE TM 77



THE PERFORMANCE TM 77 WINDOW SYSTEM EPITOMIZES SECURITY AND INNOVATION IN MODERN CONSTRUCTION. IT EXCELS IN THERMAL INSULATION, SOUNDPROOFING, AND WEATHER RESISTANCE. WITH SPECIALIZED SEPARATORS IN ITS ALUMINUM PROFILES, THIS SYSTEM STANDS OUT AS A DURABLE, HIGH-PERFORMING CHOICE FOR CONTEMPORARY ARCHITECTURE.



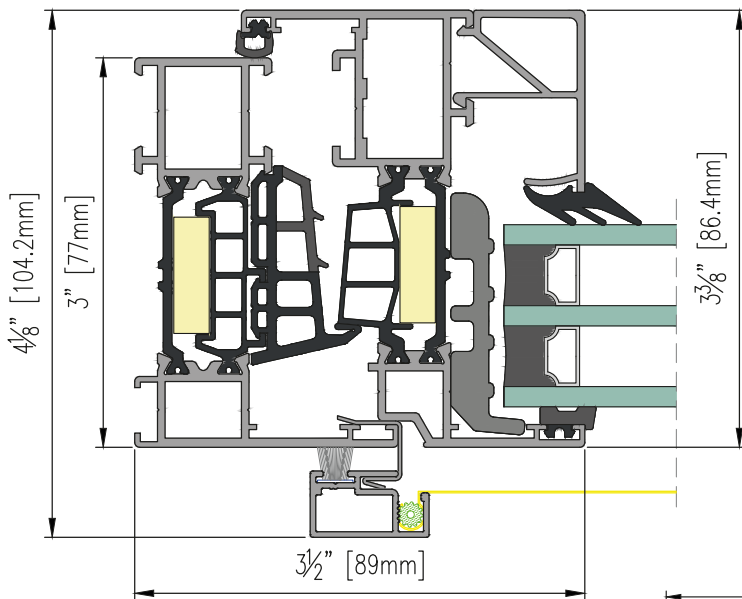

PERFORMANCE TM 77 TILT&TURN WINDOW WITH INSECT SCREEN

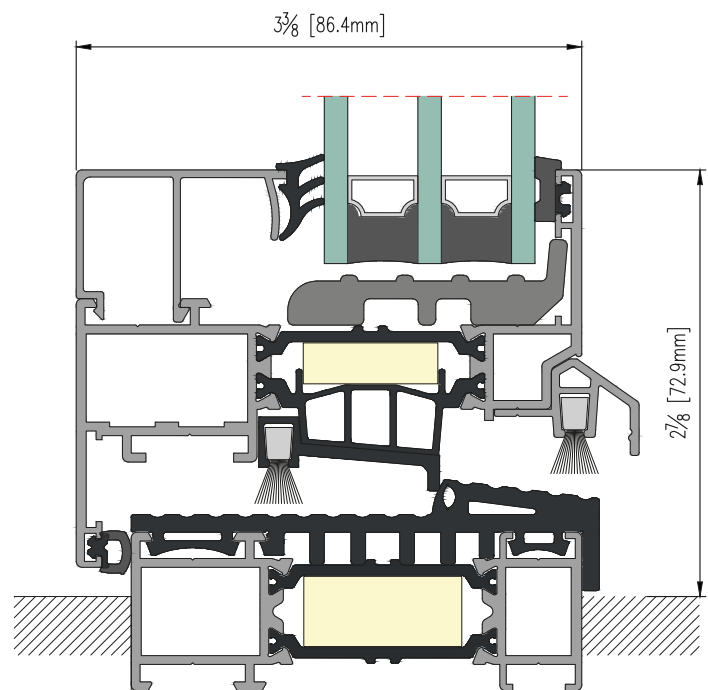

PERFORMANCE TM 77 BALCONY TILT&TURN WINDOW



### FEATURES:

- Passive Certified
- Suitable for passive buildings and net-zero energy applications
- Highest performance and tightness
- Suitable for producing windows, doors, and display windows with enhanced security features
- Outward-opening option available
- Hidden panel option
- Broad glazing surfaces for enhanced natural light



### TECHNICAL PARAMETERS:

- Water Tightness: **15 psf**
- Designed Pressure: **CW 75 psf**
- Thermal Insulation: **From 0.12 Btu/hft<sup>2</sup>F**
- Acoustic Insulation: **STC up to 48 dB**
- Maximum Panel Weight: **660 lbs (300 kg)**
- Maximum Panel Height: **10 ft (3m)**
- Maximum Panel Width: **5 ft (1,5m)**
- Glazing: **Double and triple**



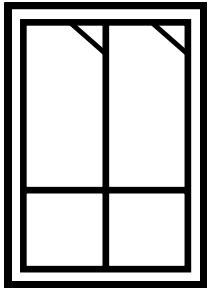

WINDOWS

# ECO TM 62



ENGINEERED WITH A BUDGET APPROACH IN MIND, IT'S AN IDEAL SOLUTION FOR REDUCING HEAT AND ENHANCING COMFORT IN BOTH RESIDENTIAL AND COMMERCIAL SPACES, BLENDING FUNCTIONALITY WITH AESTHETIC APPEAL.



ECO TM 62 TILT&TURN WINDOW WITH INSECT SCREEN

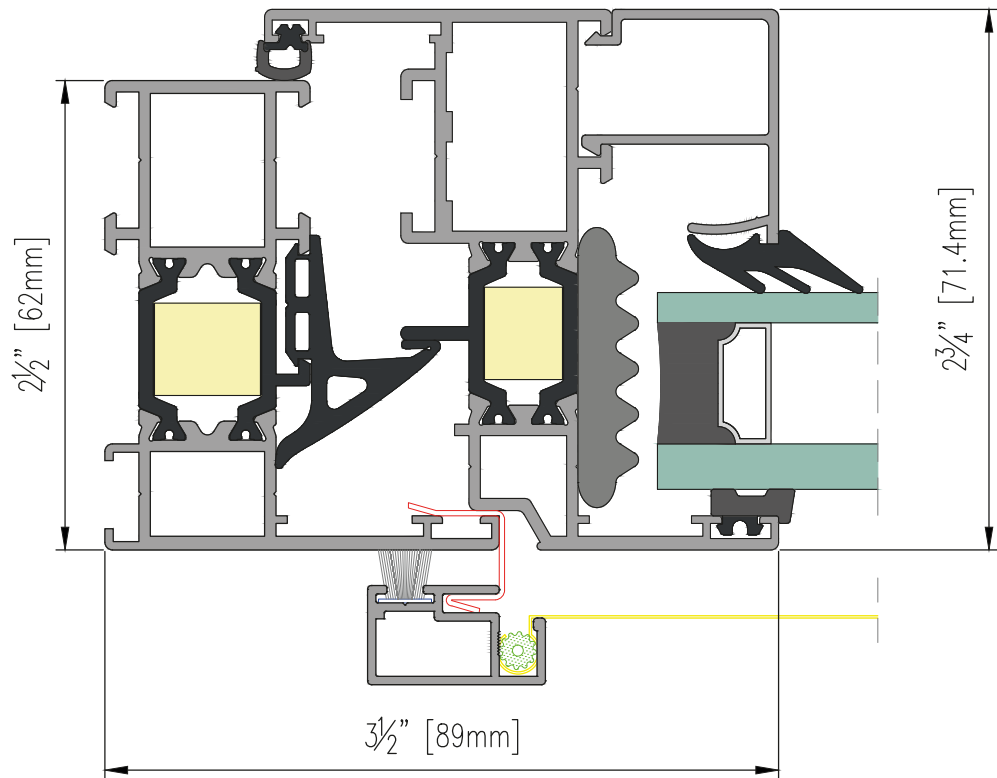

WINDOWS

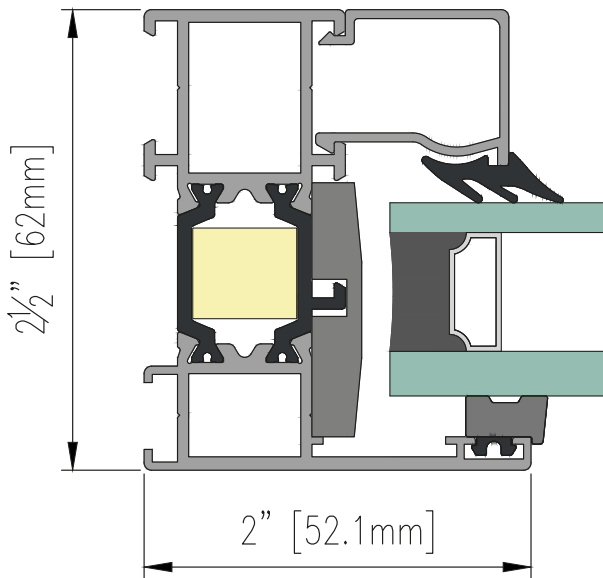

ECO TM 62  
FIXED WINDOW



FEATURES:

- Cost-efficient for light commercial applications
- Option for casement
- Minimal sightlines for enhanced visibility
- Concealed panel option



TECHNICAL  
PARAMETERS:

- Water Tightness: **15 psf**
- Designed Pressure: **CW 75 psf**
- Thermal Insulation: **From 0.17 Btu/hft<sup>2</sup>F**
- Acoustic Insulation: **STC up to 46 dB**
- Maximum Panel Weight: **660 lbs (300 kg)**
- Maximum Panel Height: **10 ft (3m)**
- Maximum Panel Width: **5 ft (1,5m)**
- Glazing: **Double and triple**

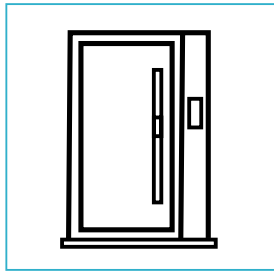

# DOORS

DISCOVER THE ARTISTRY OF OUR DOOR COLLECTION, WHERE INNOVATIVE DESIGN MEETS PRACTICAL ELEGANCE. EACH DOOR IN OUR RANGE IS A TESTAMENT TO MODERN ARCHITECTURE, BLENDING FUNCTIONALITY WITH STYLE. THEY ARE MORE THAN JUST ENTRANCES – THEY ARE STATEMENTS OF SOPHISTICATION AND SUSTAINABILITY, ENHANCING ANY SPACE WITH THEIR PRESENCE.









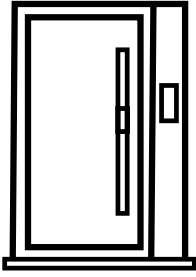

DOORS

# MOREVIEW



ADVANCED DESIGN INTEGRATION AND PRACTICAL ELEGANCE, TAILORED FOR MODERN ARCHITECTURE. EACH DOOR IS A FUSION OF FUNCTIONAL EXCELLENCE AND STYLISTIC INNOVATION, SERVING NOT ONLY AS AN ENTRANCE BUT AS A SOPHISTICATED, SUSTAINABLE ENHANCEMENT TO ANY SPACE.

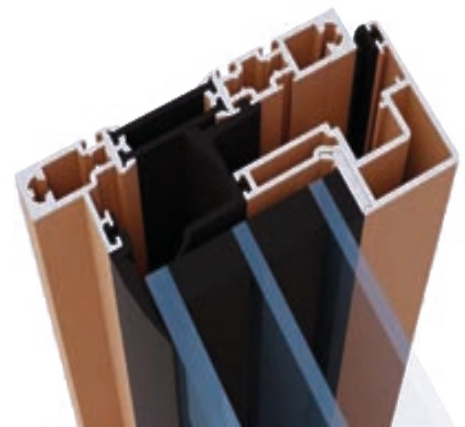



MOREVIEW INWARD OPENED DOOR

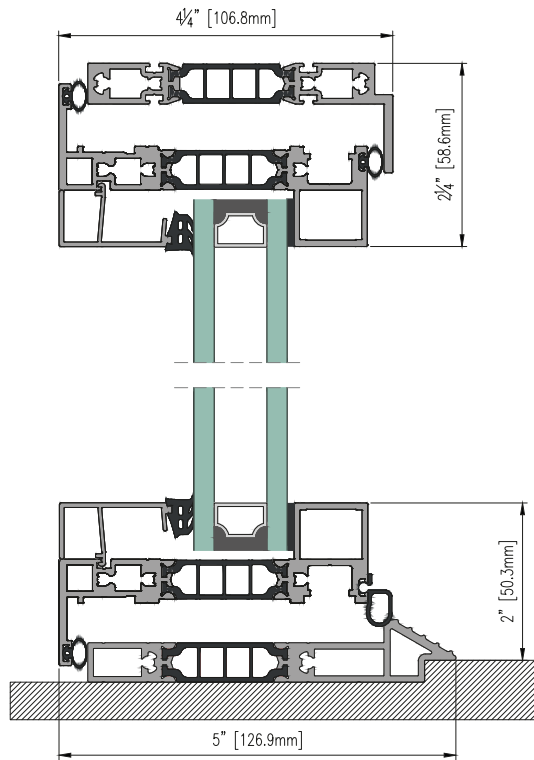

MOREVIEW OUTWARD OPENED DOORS

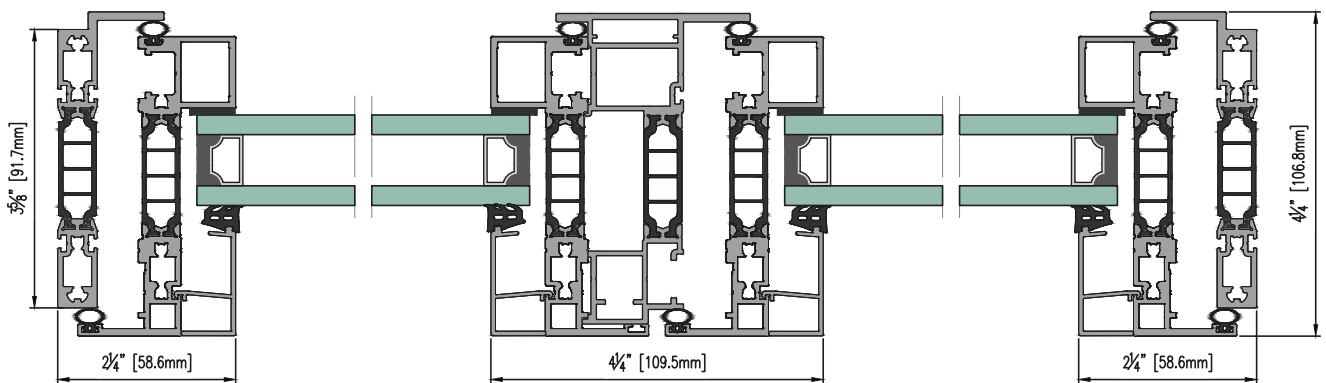

### FEATURES:

- Suitable for commercial applications
- Design as a replacement for steel doors
- Contemporary look
- Configurable window designs with mullion options
- Adaptive designs for windows and balcony doors, supporting multiple threshold types
- Visible width minimized to 2.1 inches (56mm)
- LockBox with notched glass



### TECHNICAL PARAMETERS:

- Water Tightness: **9 psf**
- Designed Pressure: **LC 50 psf**
- Thermal Insulation: **From 0.20 Btu/hft<sup>2</sup>F**
- Acoustic Insulation: **STC up to 42 dB**
- Maximum Panel Weight: **300 lbs (150 kg)**
- Maximum Panel Height: **10 ft (3m)**
- Maximum Panel Width: **5 ft (1.5m)**
- Glazing: **Double and triple**



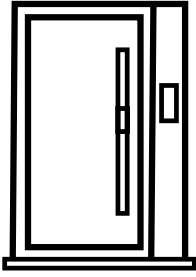

DOORS

# PASSIVE TM 102



THESE DOORS ARE A TESTAMENT TO ENERGY-EFFICIENT DESIGN AND ARCHITECTURAL HARMONY. REPRESENTING THE IDEAL UNION OF CONTEMPORARY AESTHETICS AND ECO-CONSCIOUSNESS, EACH ENTRANCE BECOMES AN UPSCALE LIVING EXPERIENCE.





PASSIVE TM 102  
INWARD OPENED DOOR

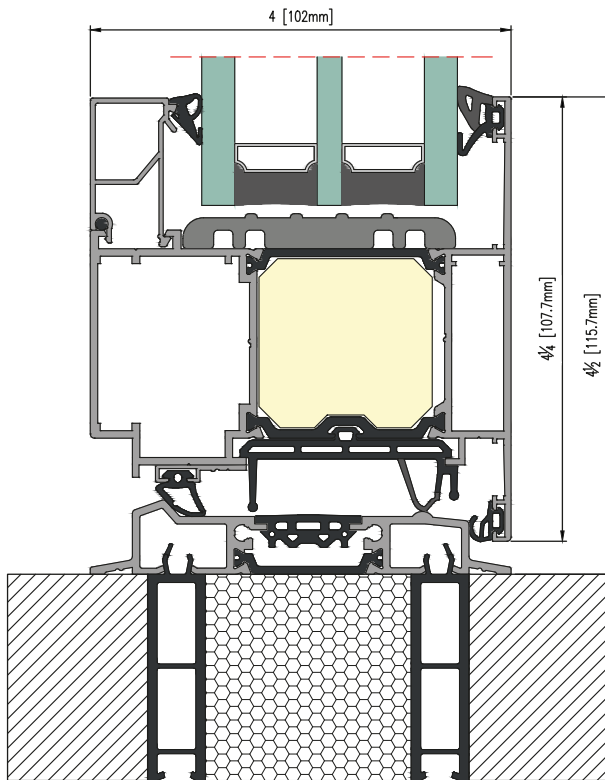
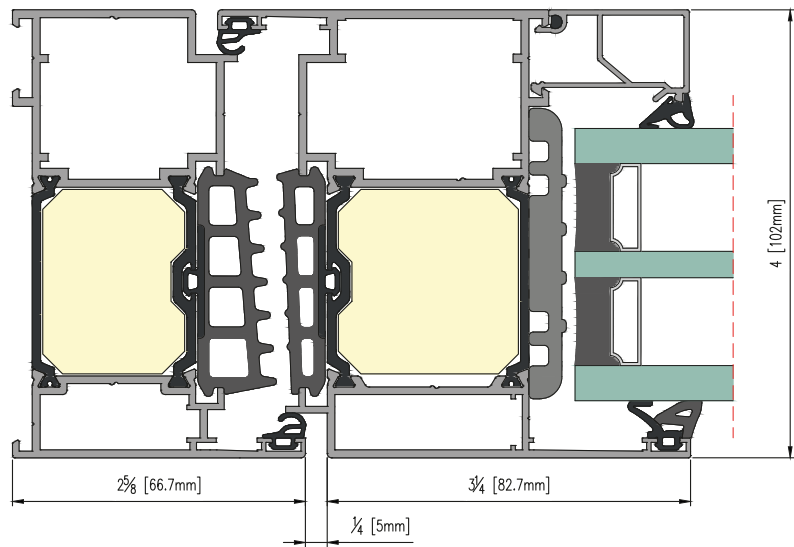

PASSIVE TM 102 OUTWARD  
OPENED DOOR WITH TRESHOLD



### FEATURES:

- Outstanding thermal insulation
- Option for 4 glass panes
- Available in single and double door designs
- Supports tall constructions using innovative techniques
- Integrated with side and top lights



### TECHNICAL PARAMETERS:

- Water Tightness: **9 psf**
- Designed Pressure: **CW 60 psf**
- Thermal Insulation: **From 0.12 Btu/hft<sup>2</sup>F**
- Acoustic Insulation: **STC up to 45 dB**
- Maximum Panel Weight: **550 lbs (250 kg)**
- Maximum Panel Height: **10 ft (3m)**
- Maximum Panel Width: **4,5 ft (1,4m)**
- Glazing: **Triple**

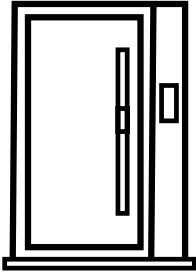

DOORS

# PERFORMANCE TM 77 PRESTIGE



EXPERIENCE THE FUSION OF LUXURY AND TECHNOLOGY WITH PERFORMANCE PRESTIGE DOORS. MORE THAN JUST ENTRYWAYS, THESE DOORS REPRESENT A MARK OF REFINED TASTE AND ADVANCED INNOVATION. TAILORED FOR DISCERNING HOMEOWNERS, THEY COMBINE CUSTOMIZED DESIGN WITH SMART FUNCTIONALITY, TURNING EVERY ENTRANCE INTO AN EXTRAORDINARY MOMENT.





PERFORMANCE TM 77 PRESTIGE OUTWARD OPENED DOOR

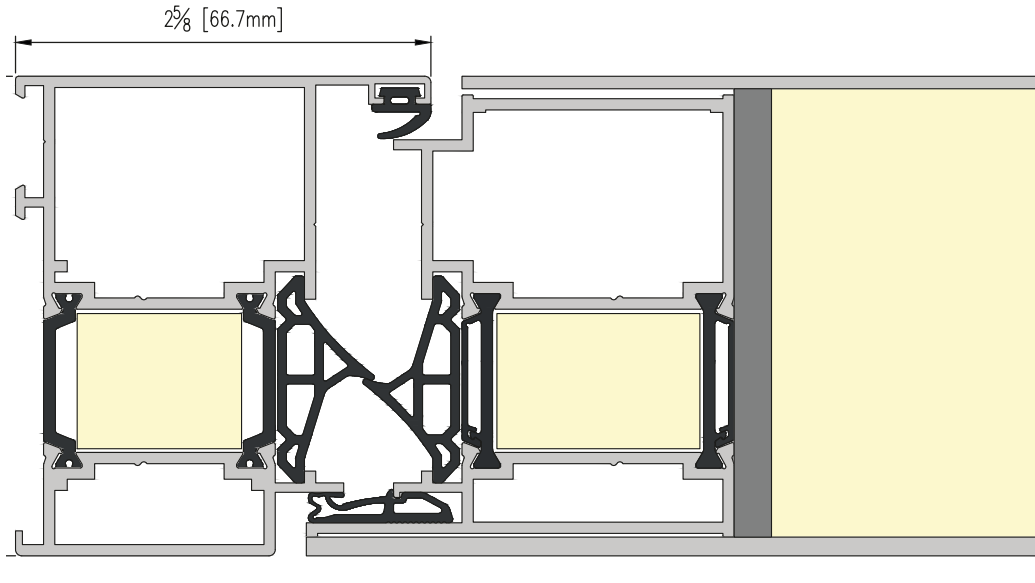

PERFORMANCE TM 77 PRESTIGE  
OUTWARD OPENED DOOR  
WITH TRESHOLD

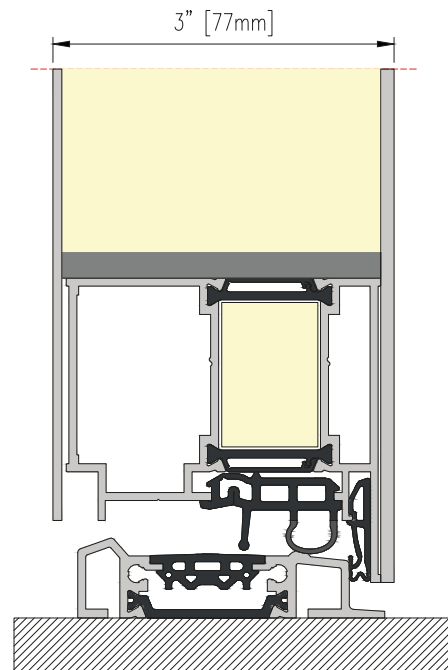

FEATURES:

- Integrated with side and top lights
- Customizable panel design with stainless steel appliqué and decorative mullions
- Wide selection of paints and finishes
- Versatile options for bespoke entrance doors
- Adhered glass option
- ADA compliant
- Automated opening functionality
- Superior water, air, thermal, and fire resistance
- Seamless integration with Yawal USA systems
- Dedicated hardware solutions
- Enhanced access control features



TECHNICAL PARAMETERS:

- Water Tightness: **9 psf**
- Designed Pressure: **CW 60 psf**
- Thermal Insulation: **From 0.12 Btu/hft<sup>2</sup>F**
- Acoustic Insulation: **STC up to 33 dB**
- Maximum Panel Height: **10 ft (3m)**
- Maximum Panel Width: **4,5 ft (1,4m)**



DOORS

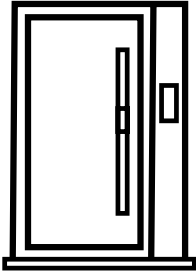

DOORS

# PERFORMANCE TM 77



STEP INTO THE WORLD OF PERFORMANCE TM 77 WHERE GLASS EXUDES GRANDEUR. THESE DOORS BLEND SLEEK DESIGN WITH CUTTING-EDGE TECHNOLOGY, TRANSFORMING SPACES INTO SANCTUARIES OF LIGHT AND OPULENCE. PERFECT FOR THOSE DESIRING TO MERGE INDOOR AND OUTDOOR SPACES, PERFORMANCE TM 77 DOORS OFFER MESMERIZING PANORAMIC VIEWS.



PERFORMANCE TM 77  
INWARD OPENED DOOR

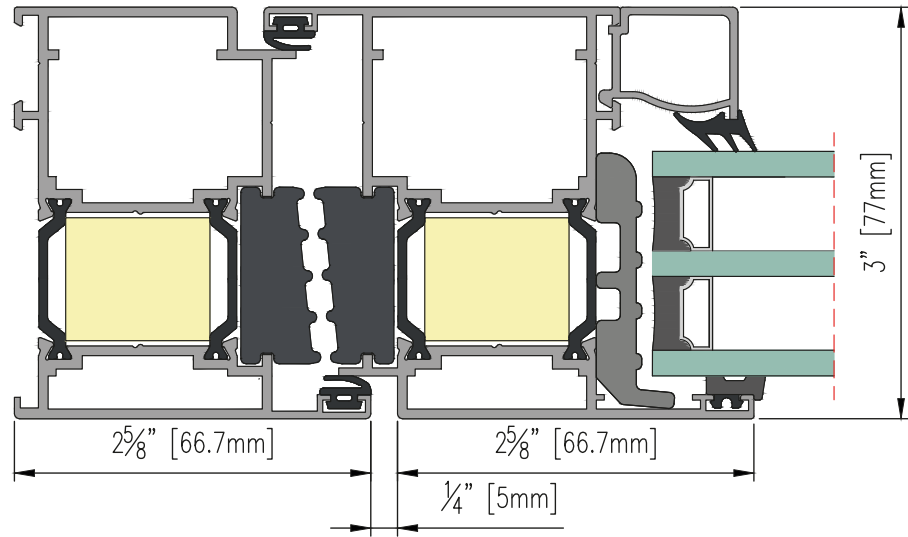

DOORS

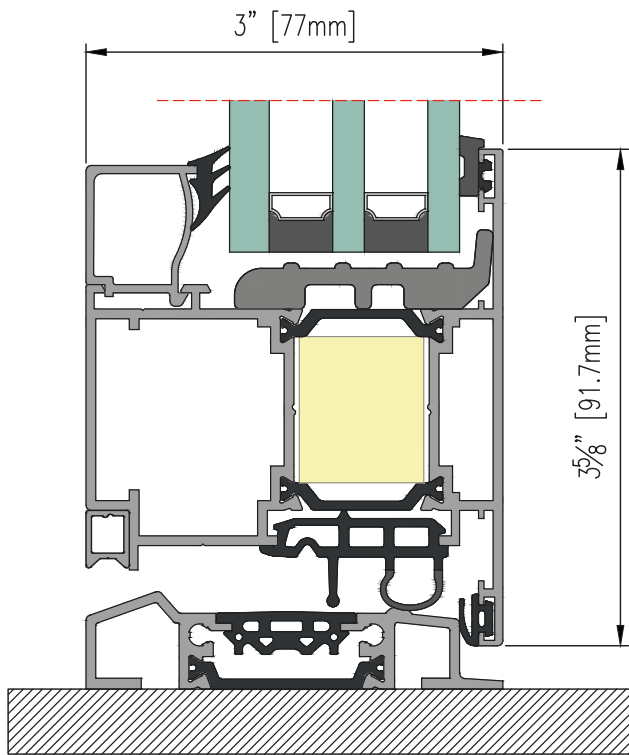

PERFORMANCE TM 77  
OUTWARD OPENED  
DOOR WITH TRESHOLD



FEATURES:

- Advanced thermal insulation
- Suitable for heavy commercial use
- Oversized dimensions
- Integrated with side and top lights
- Enhanced access control features
- Compatible with the „intelligent house” concept



TECHNICAL  
PARAMETERS:

- Water Tightness: **9 psf**
- Thermal Insulation: **From 0.15 Btu/hft2F**
- Designed Pressure: **CW 60 psf**
- Acoustic Insulation: **STC up to 44 dB**
- Maximum Panel Weight: **550 lbs (250 kg)**
- Maximum Panel Height: **10 ft (3m)**
- Maximum Panel Width: **4,5 ft (1,4m)**
- Glazing: **Double and triple**



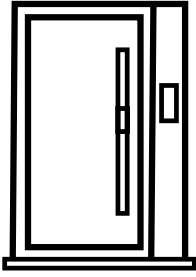

DOORS

# ECO TM 62



DISCOVER THE ECO TM 62 DOORS,  
WHERE BEAUTY MEETS EFFICIENCY.  
THESE PREMIUM DOORS EMBODY FINE  
CRAFTSMANSHIP AND ECO-AWARENESS.



ECO TM 62  
INWARD OPENED  
DOOR

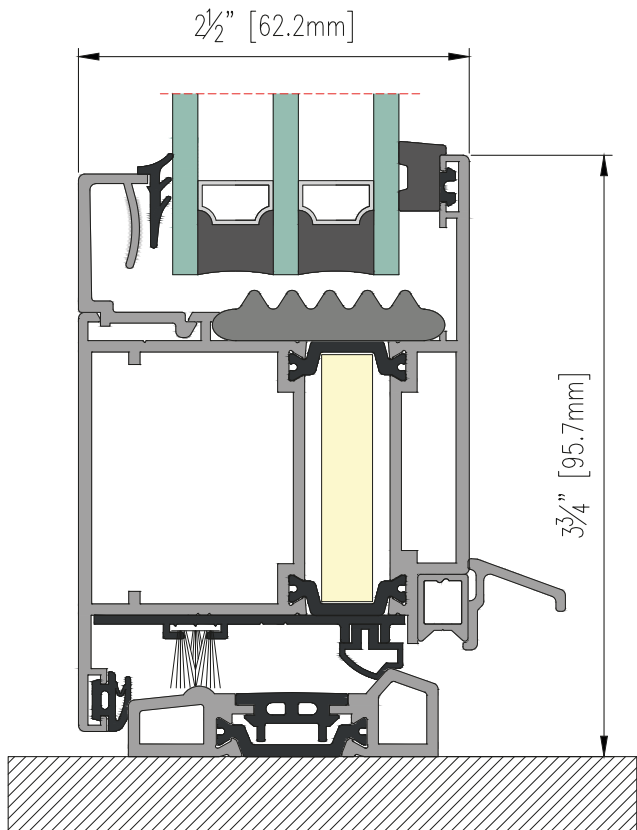
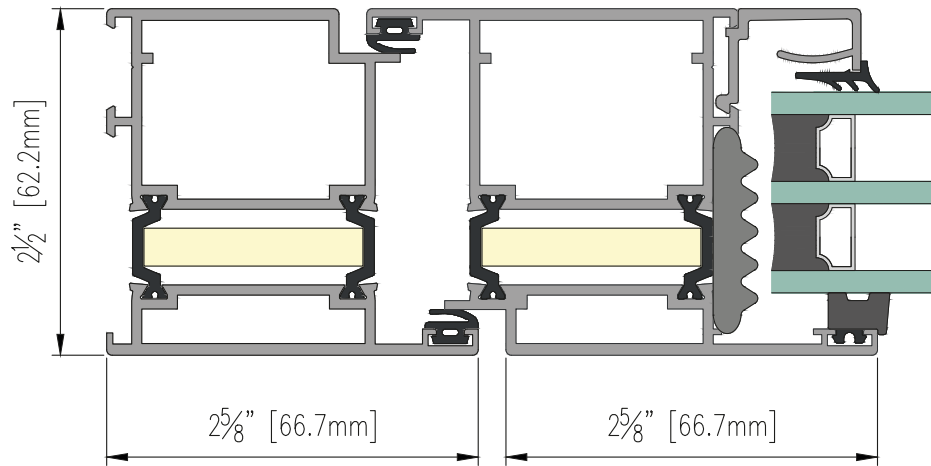

ECO TM 62 INWARD  
OPENED DOOR  
WITH TRESHOLD



### FEATURES:

- Ideal for commercial applications
- Fully integrated with storefront profiles
- Efficient installation process
- Advanced thermal insulation
- Integrated with side and top lights
- Enhanced access control features and panic devices



### TECHNICAL PARAMETERS:

- Water Tightness: **9 psf**
- Thermal Insulation: **From 0.20 Btu/hft<sup>2</sup>F**
- Acoustic Insulation: **STC up to 42 dB**
- Maximum Panel Weight: **550 lbs (250 kg)**
- Maximum Panel Height: **10 ft (3m)**
- Maximum Panel Width: **4,5 ft (1,4m)**
- Glass Thickness: **double and triple glazed**
- Glazing: **Double and triple**



DOORS

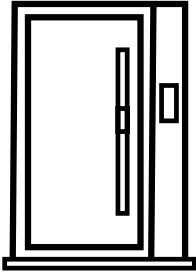

DOORS

# INTERIOR PBI 50



CRAFTED FOR ELEGANT INTERIOR SOLUTIONS, THE INTERIOR SYSTEM EXCELS IN CREATING NON-THERMALLY INSULATED PARTITIONS AND STRUCTURES.





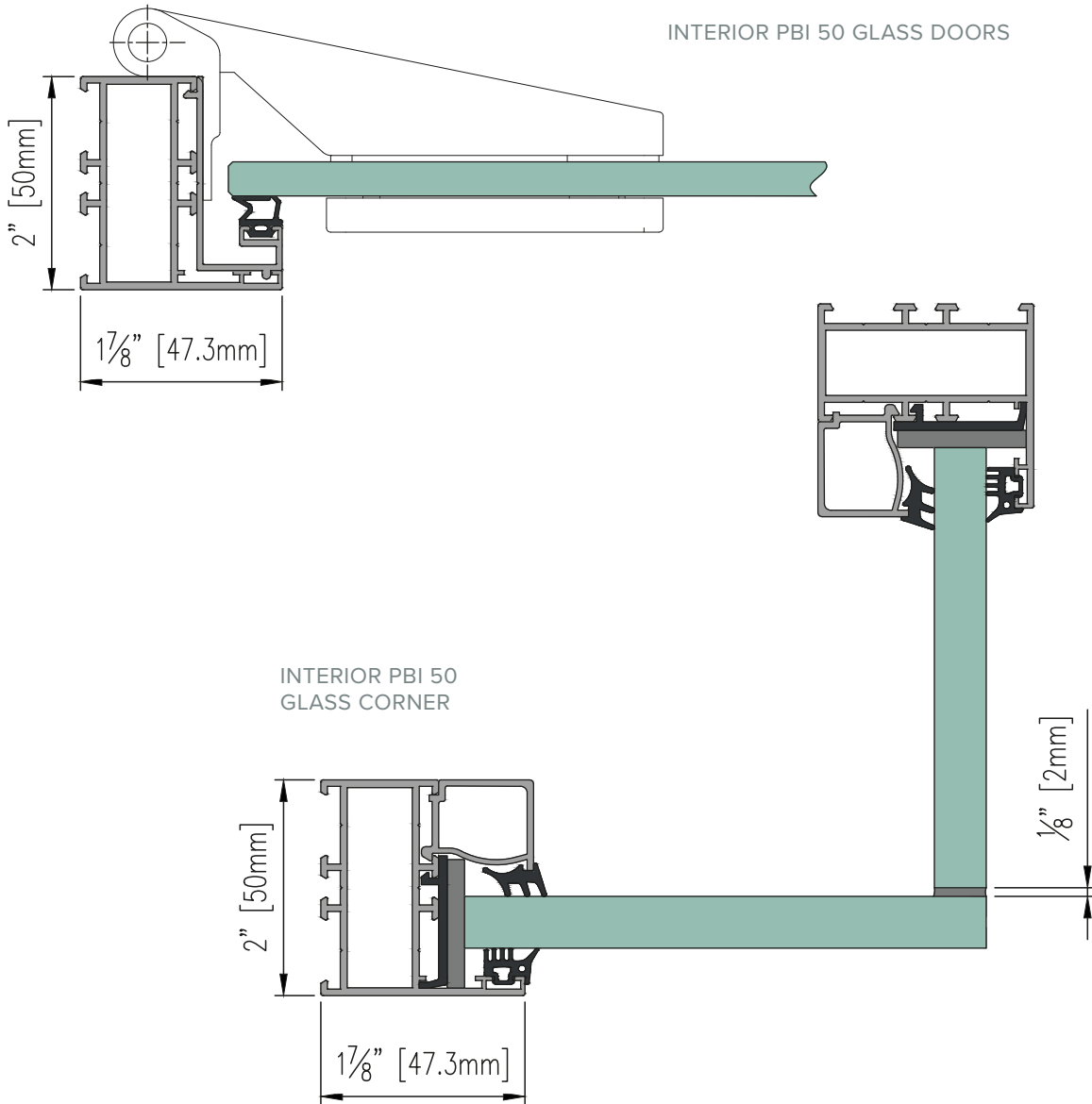

## FEATURES:

- Suitable for light walls and high-performance internal partitions
- Allows creation of all-glass structures
- Option for crosspieces dividing the glazing
- Various contour profiles available, with walls settable at any angle
- Options for outward and inward opening doors, all-glass, single-panel, double-panel doors, and service windows
- Capability to manufacture smoke-proof constructions
- Simple installation process



## TECHNICAL PARAMETERS:

- Acoustic Insulation: **STC up to 48 dB**
- Maximum Fix Partition Size: **10,1 ft (3100m)**
- Maximum Single Panel Height: **3,9 ft (1,2m)**
- Maximum Single Panel Width: **7,8 ft (2,4m)**
- Maximum Double Panel Height: **7,1 ft (2,2m)**
- Maximum Double Panel Width: **7,8 ft (2,4m)**

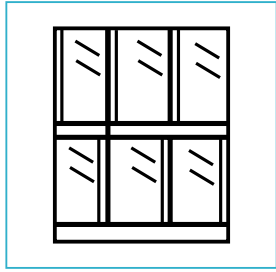

# CURTAIN WALLS

OUR CURTAIN WALLS EMBODY THE PINNACLE OF MODERN ARCHITECTURAL DESIGN, FUSING GROUNDBREAKING ENGINEERING WITH VISUAL SPLENDOR. THESE FACADE SYSTEMS TRANSFORM SKYLINES AND ENHANCE LIVING SPACES, OFFERING A BACKDROP FOR ARCHITECTURAL CREATIVITY AND SUSTAINABLE, FUNCTIONAL DESIGN.









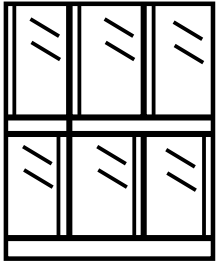

## CURTAIN WALLS

# FA 50N DESIGN LINE



THE DESIGN LINE CURTAIN WALL SYSTEM STANDS AS A MARVEL OF ARCHITECTURAL INNOVATION, SEAMLESSLY COMBINING SLEEK AESTHETICS WITH SUPERIOR THERMAL, ACOUSTIC, AND ENVIRONMENTAL PERFORMANCE. IDEAL FOR COMMERCIAL AND UPSCALE RESIDENTIAL BUILDINGS, IT TURNS ANY FACADE INTO A VISUALLY CAPTIVATING MASTERPIECE.

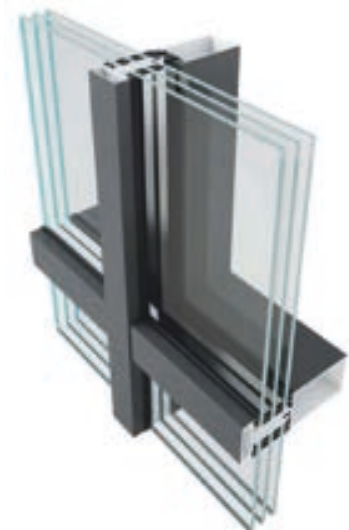



CAPS:

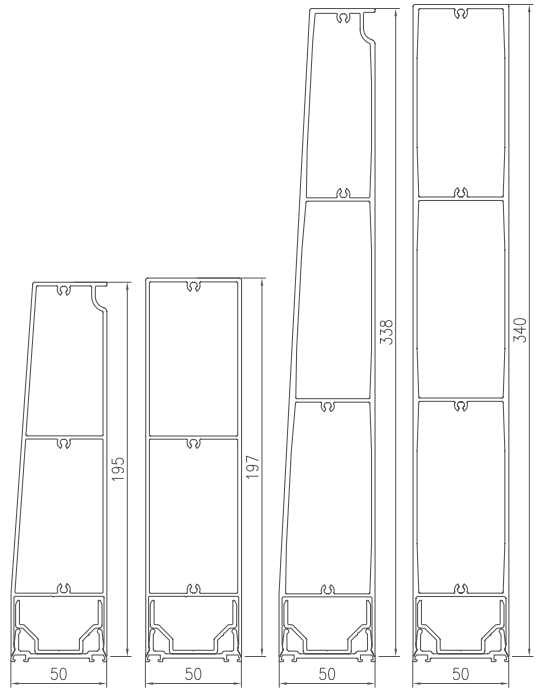
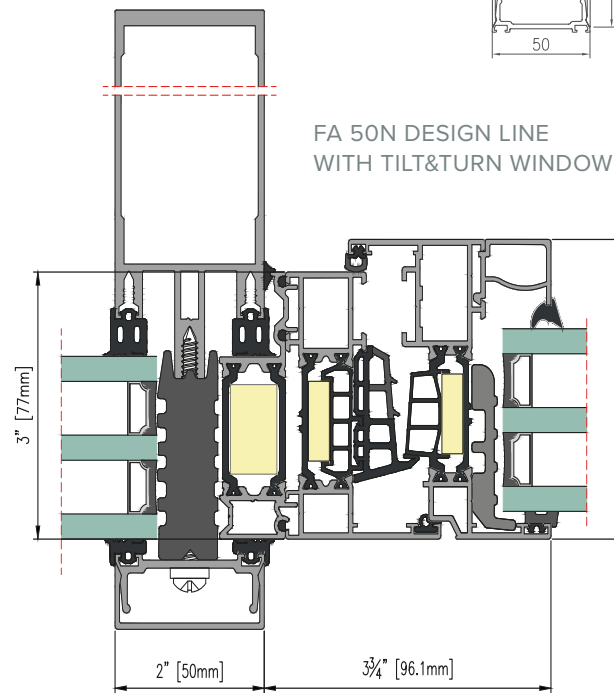
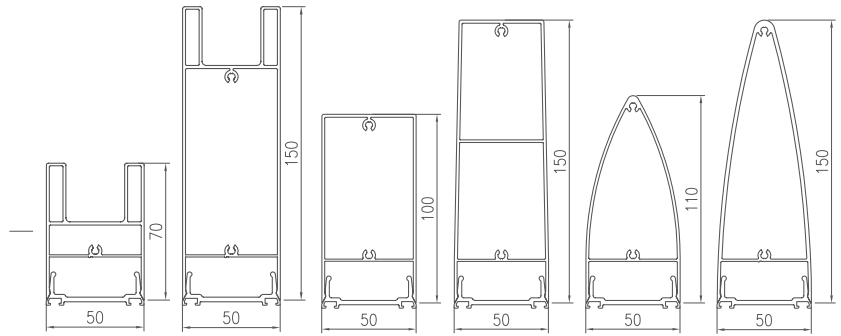
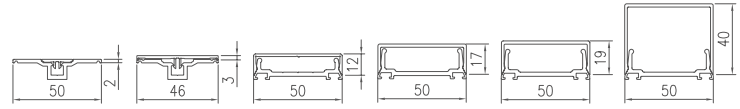
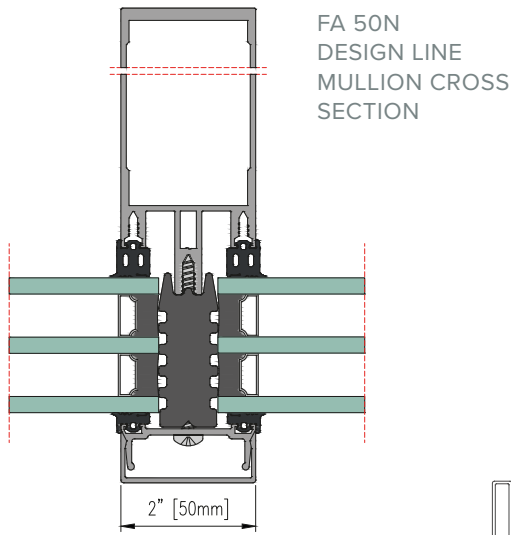

CURTAIN WALLS



## FEATURES:

- No size limitations
- Supports diverse structures including turns, bends, and polygons
- Various cover cap options for different curtain wall aesthetics
- Superior thermal performance
- Optimal tightness with aesthetic excellence
- Efficient installation process



## TECHNICAL PARAMETERS:

- Water Tightness: **15 psf**
- Designed Pressure: **CW 75 psf**
- Thermal Insulation: **From 0.11 Btu/hft<sup>2</sup>F**
- Acoustic Insulation: **STC up to 53 dB**
- Glazing: **Double and triple**

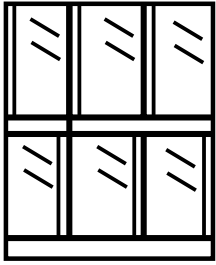

CURTAIN WALLS

# FA 50N SMOOTH LINE



THIS CURTAIN WALL SYSTEM INTEGRATES QUICK ASSEMBLY WITH THE BEAUTY OF A STRUCTURAL FACADE, STRIKING A PERFECT BALANCE BETWEEN FORM AND FUNCTION.

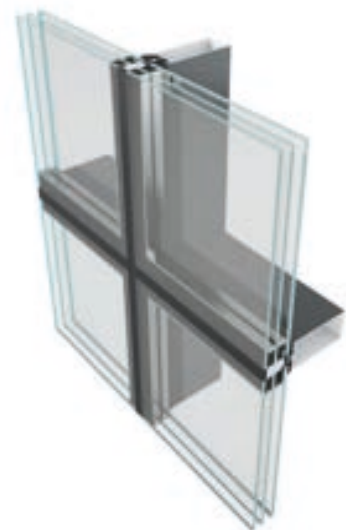



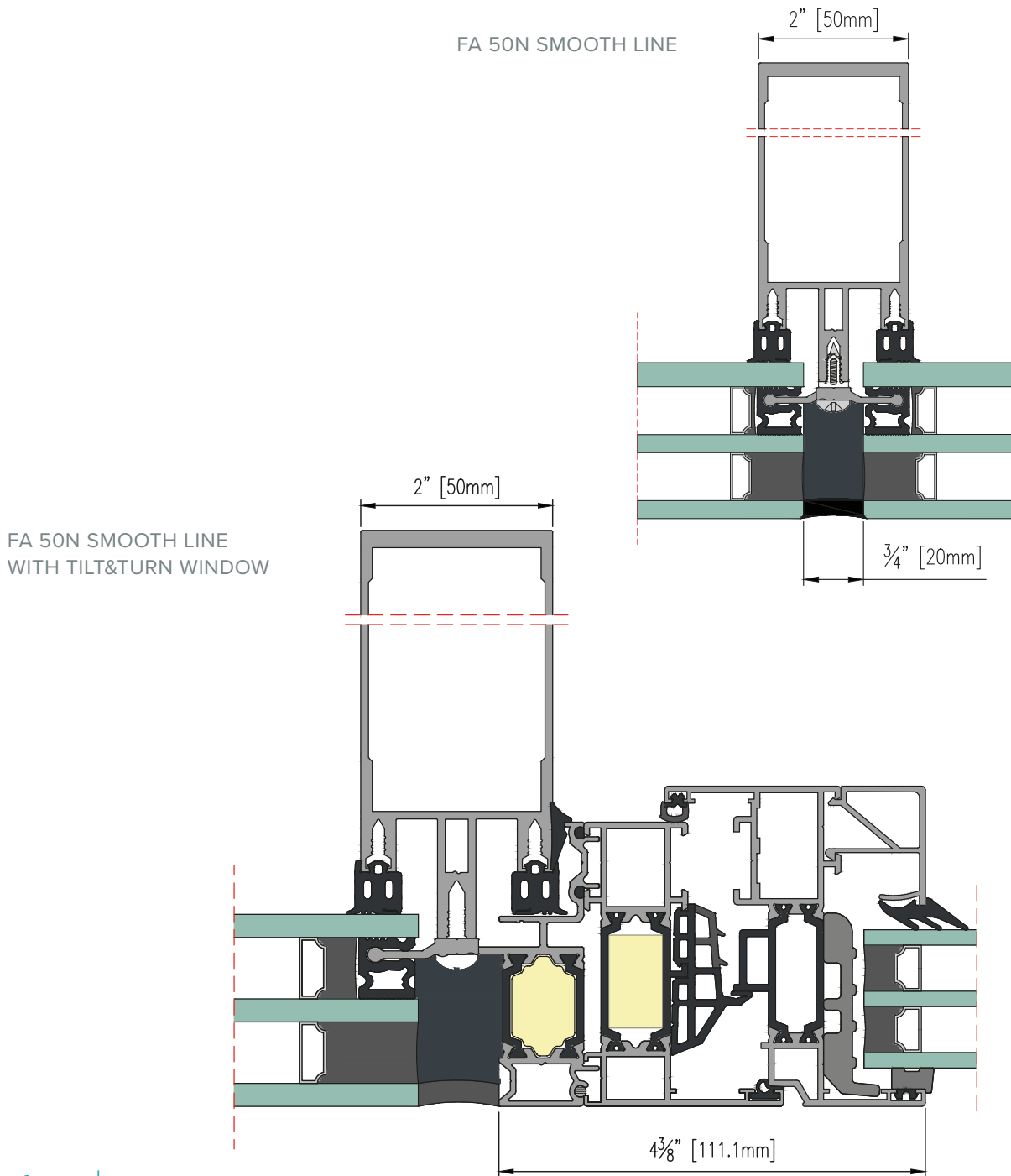

## FEATURES:

- Clean glass facade design, no external slats
- Unified large glass appearance for a semi-structural glazing look
- No size limitations
- Superior thermal performance
- Supports diverse structures, including turns, bends, and polygons
- Optimal tightness with aesthetic excellence
- Efficient installation process



## TECHNICAL PARAMETERS:

- Water Tightness: **15 psf**
- Designed Pressure: **CW 75 psf**
- Thermal Insulation: **From 0.14 Btu/hft<sup>2</sup>F**
- Acoustic Insulation: **STC up to 50 dB**
- Glazing: **Double and triple**

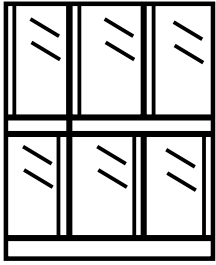

CURTAIN WALLS

# PANORAMIC CW WINDOW



THIS MODERN SOLUTION BLENDS CURTAIN WALL ELEGANCE WITH WINDOW PRACTICALITY, FEATURING AN 'INVISIBLE' FRAME FROM THE OUTSIDE FOR A SLEEK, CONTINUOUS FACADE.



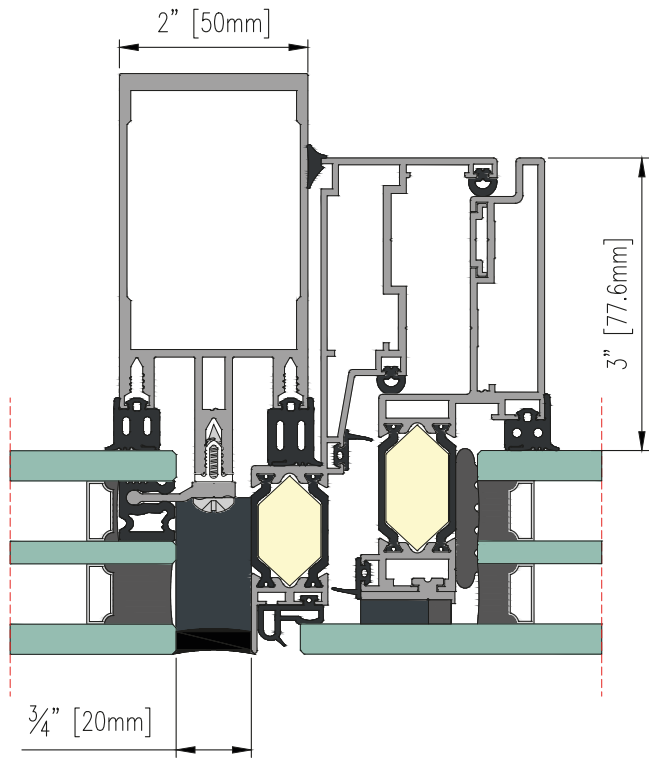

SMOOTH LINE PANORAMIC CW  
OUTWARD OPENED WINDOW

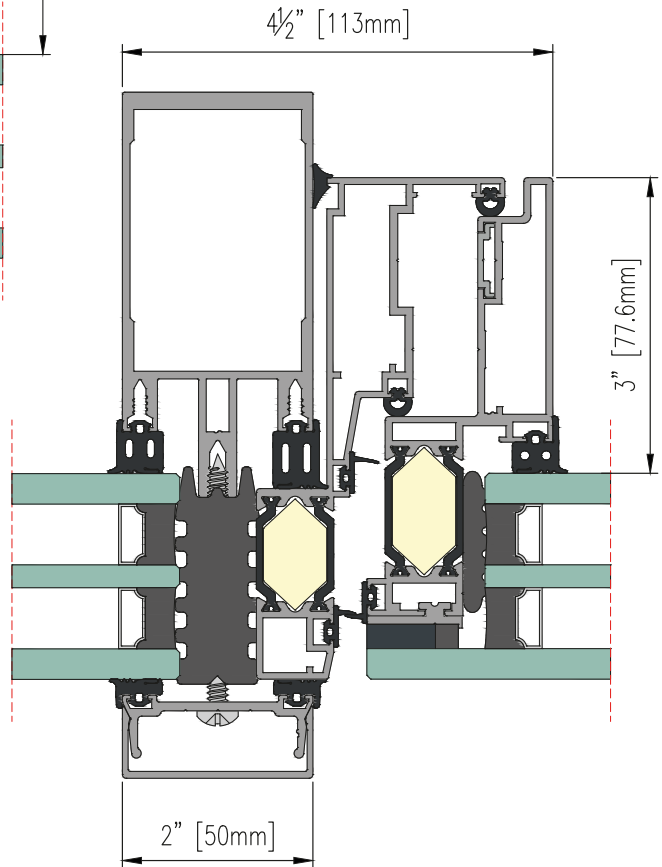

DESIGN LINE PANORAMIC CW  
OUTWARD OPENED WINDOW



### FEATURES:

- Options: Hopper, top-hung, casement, parallel windows
- Superior thermal performance
- Oversized dimensions
- Uniform surface visual, enhancing building aesthetics
- Efficient ventilation with sliding windows for facade uniformity
- Supports automated opening/closing actuators installation



### TECHNICAL PARAMETERS:

- Water Tightness: **15 psf**
- Designed Pressure: **CW 65 psf**
- Thermal Insulation: **0.15 Btu/hft<sup>2</sup>F**
- Acoustic Insulation: **STC up to 44 dB**
- Maximum Panel Weight: **660 lbs (300 kg)**
- Maximum Panel Height: **10 ft (3M)**
- Maximum Panel Width: **6 ft (1,8M)**
- Glazing: **Double and triple**



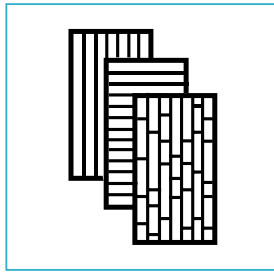

# ADD ONS

DESIGNED TO SEAMLESSLY INTEGRATE WITH ANY SETTING, THESE ADD-ONS ELEVATE THE OVERALL AESTHETIC WHILE ENSURING PRACTICALITY AND COMFORT.







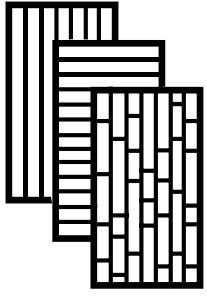

ADD ONS

# SUNSHADES AND LOUVERS



OUR SUNSHADES AND LOUVERS  
ARE DESIGNED FOR MAXIMUM SUN  
CONTROL.





## SUNSHADES

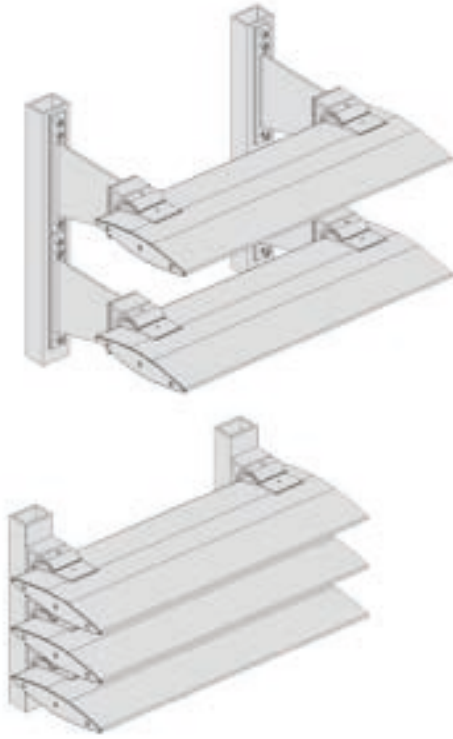

## SUNSHADES SECTION

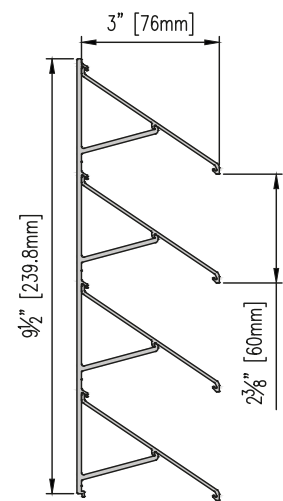
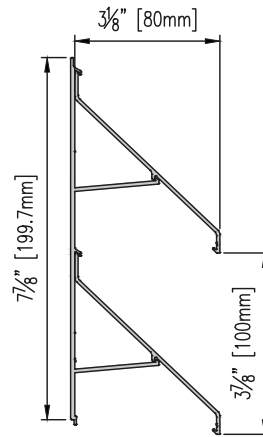
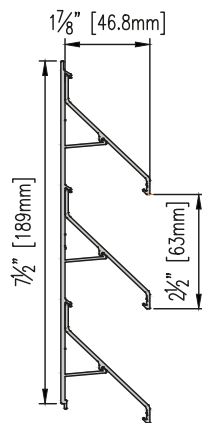
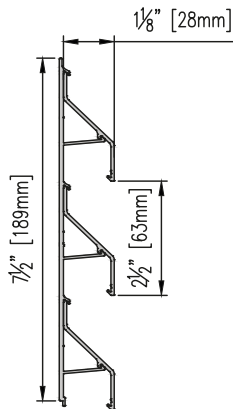
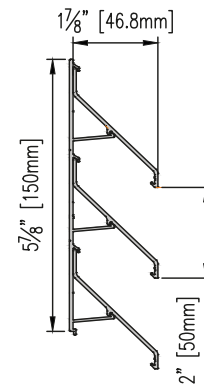
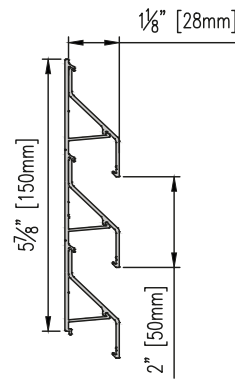
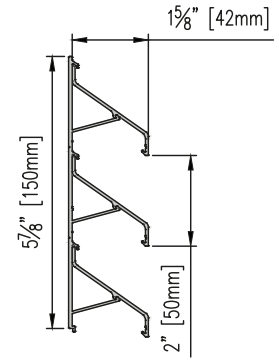

### FEATURES:

- PTAC louvers integrated with Yawal systems
- Multiple air conditioning flow options
- Options for automatic and motorized control
- Fixed and operable louver choices
- Vertical and horizontal sun protection
- Enhances unique brand appearance
- Improves indoor comfort by reflecting and diffusing light
- Increased work and life comfort with reduced sun exposure



### TECHNICAL PARAMETERS:

- Designed Pressure: **CW 50 psf**
- Maximum Panel Height: **10 ft**
- Maximum Panel Width: **6 ft**



ADD ONS

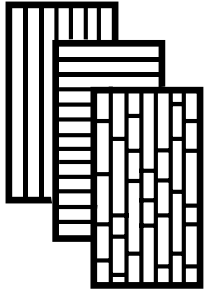

ADD ONS

# JULIET BALCONY



DESIGNED WITH STRONG, DURABLE ALUMINUM, THESE BALCONIES PROVIDE SAFETY AND AN ELEGANT ARCHITECTURAL ELEMENT, ADDING A SENSE OF OPENNESS AND SOPHISTICATION.





JULIET BALCONY WITH TILT&TURN WINDOW

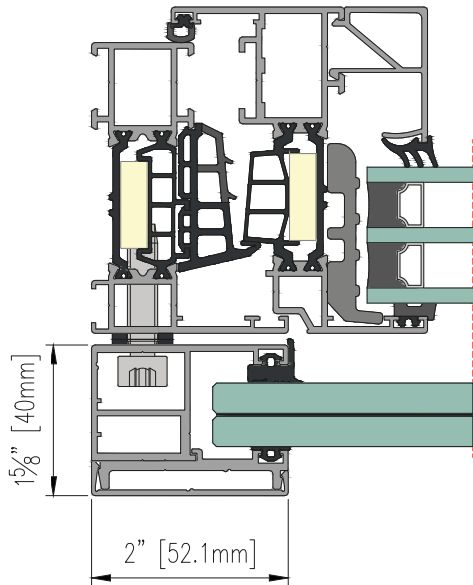

JULIET BALCONY MULLION CONNECTION TO WINDOW

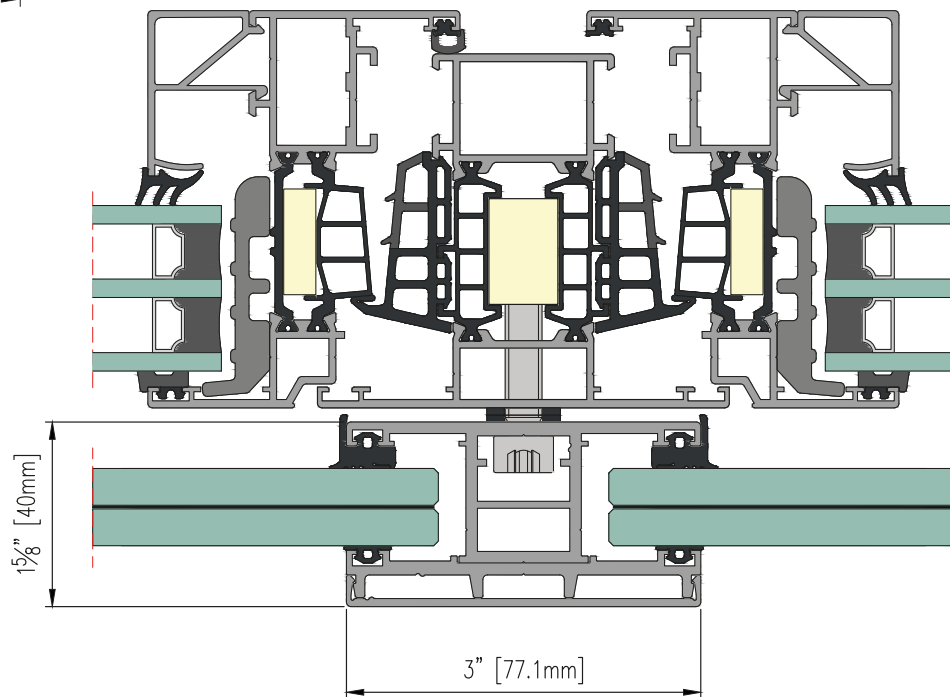

### FEATURES:

- Modern external balustrades for high-opening windows and French balconies
- Robust profiles for optimal safety
- Compatible with all Yawal windows and doors
- Design option without upper safety strip
- Suitable for single-panel and double-panel configurations
- Enhances building acoustic insulation
- Adaptable for integration at any construction stage



### TECHNICAL PARAMETERS:

#### FOR SINGLE PANEL:

- Maximum Panel Height: **4 ft (1,2M)**
- Maximum Panel Width: **4 ft (1,2m)**

#### FOR DOUBLE PANEL:

- Maximum Panel Height: **4 ft (m)**
- Maximum Panel Width: **8 ft (m)**



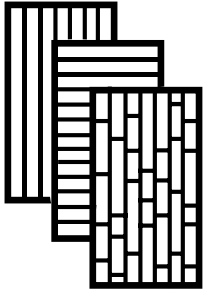

ADD ONS

# VERTILINE



TRANSFORM YOUR PROPERTY'S APPEARANCE WITH OUR VERTILINE ALUMINUM FAÇADE CLADDING. ALIGNING WITH CONTEMPORARY DESIGN TRENDS, THOSE SLATS OFFERS A PERFECT COMBINATION OF STYLE AND PRACTICALITY, WITH AN OPTION WITH LED LIGHTING TO A COLOR OF YOUR CHOICE.





VERTILINE SECTION

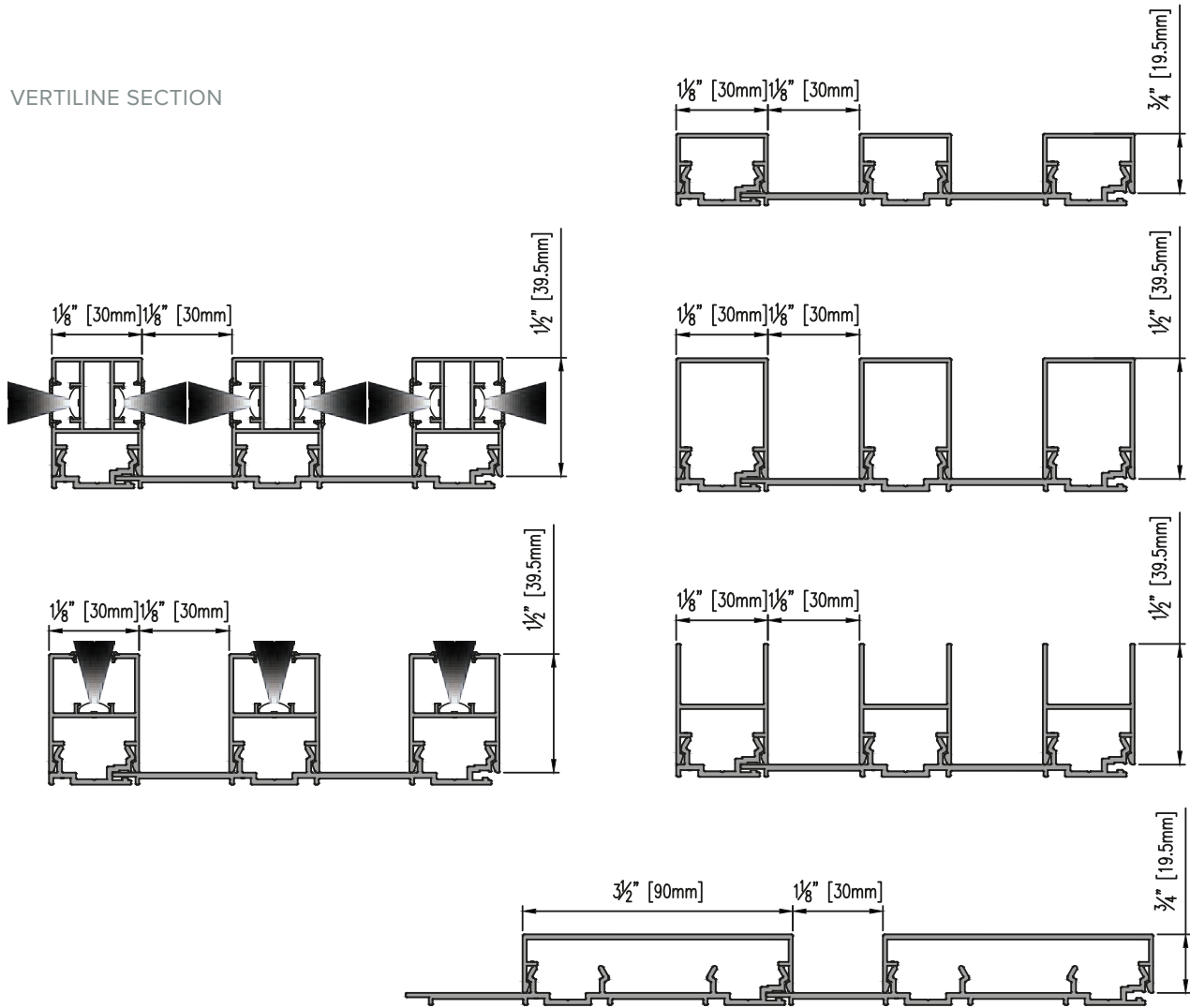

FEATURES:

- Adaptable for external and internal assembly, offering system flexibility
- Customizable shapes and colors to match architectural aesthetics
- Ensures facade uniformity for a contemporary look
- Durable, weather-resistant aluminum slats
- Maintenance-free, no repainting required
- Safe and eco-friendly, compliant with construction and environmental standards

ADDITIONAL ELEMENT:

VERTILINE PROFILE CORSS SECTIONS

- BASE PROFILE
- Z SHAPED
- SHORT SLAT
- H SHAPED
- WIDE SLAT
- FACE LED
- HIGH SLAT
- SIDE LED



TECHNICAL PARAMETERS:

- Maximum Panel Height: **Unlimited**
- Maximum Panel Width: **Unlimited**

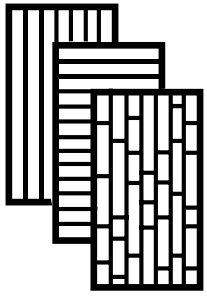

ADD ONS

# INSECT SCREEN



WE OFFER A VARIETY OF FIX, RETRACTABLE AND ACCORDEON INSECTS SCREENS, WITH CONVENIENT OPTIONS OF COMBINING WITH SUNSHADES.





PERFORMANCE TM 77  
WINDOW  
WITH INSECT SCREEN

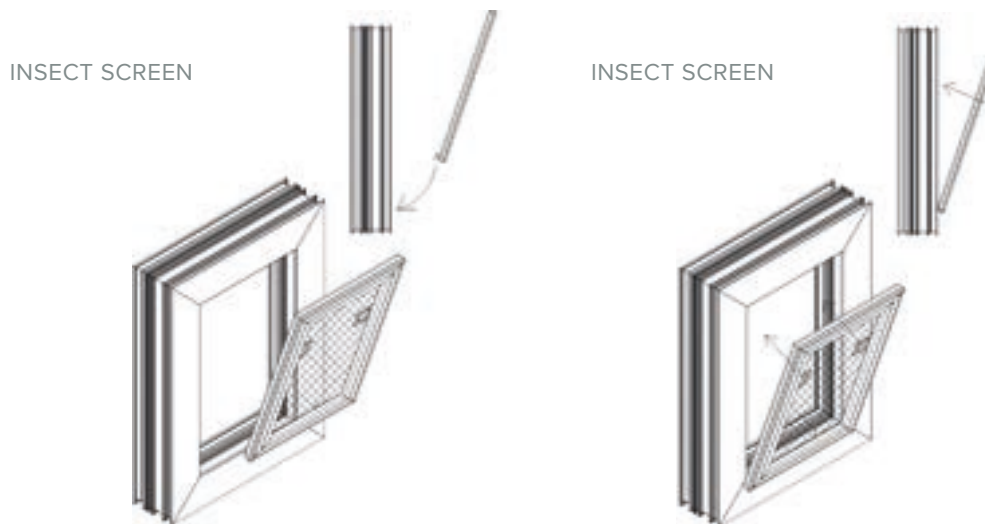
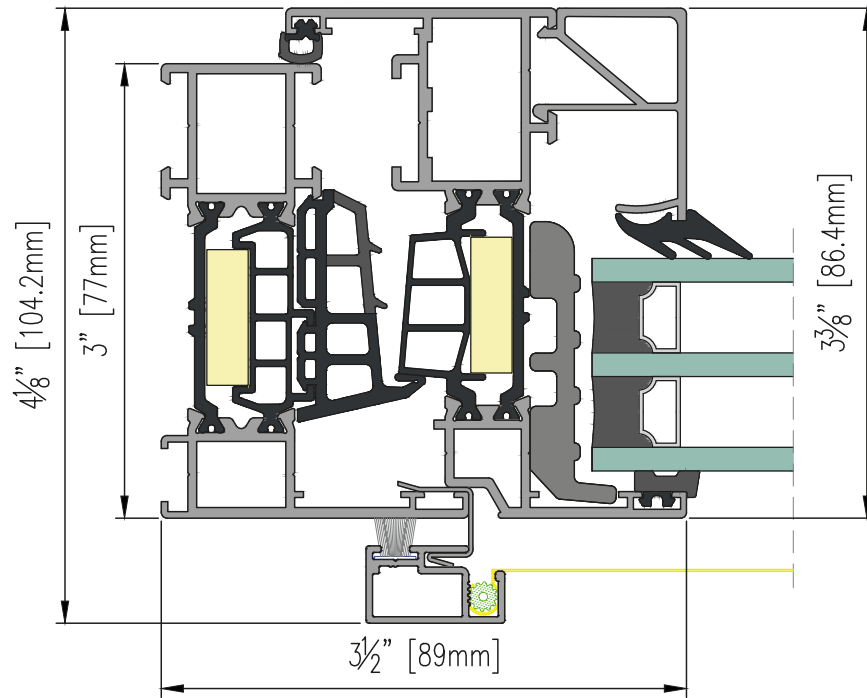

FEATURES:

- Maintains full window functionality
- Robust design for long-lasting performance
- Available in various colors
- Option for integrated construction
- Environmentally friendly and harmless to insects



TECHNICAL  
PARAMETERS:

	MAX PANEL HEIGHT	MAX PANEL WIDTH
Fix:	■ 10ft (3m)	■ 5ft (1,5m)
Retractable:	■ 8.2ft (2,5m)	■ 6.5ft (2m)
Accordeon:	■ 10ft (3m)	■ 20ft (6m)
Centor:	■ 10ft (3m)	■ 30ft (9,1m)
Sunscreen:	■ 10ft (3m)	■ 20ft (6m)

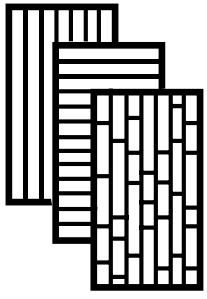

ADD ONS

# GLASS RAILINGS



IDEAL FOR BALCONIES AND TERRACES, OUR GLASS RAILINGS ARE DESIGNED FOR SAFETY AND AESTHETICS, REFLECTING CURRENT ARCHITECTURAL TRENDS WITH EXTENSIVE GLAZING.





### GLASS RAILING

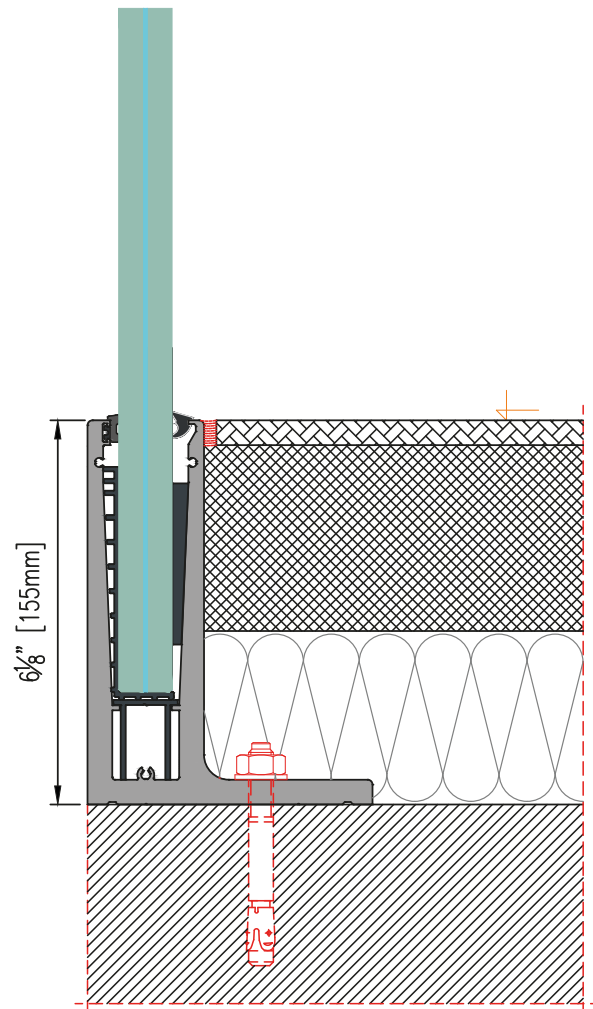
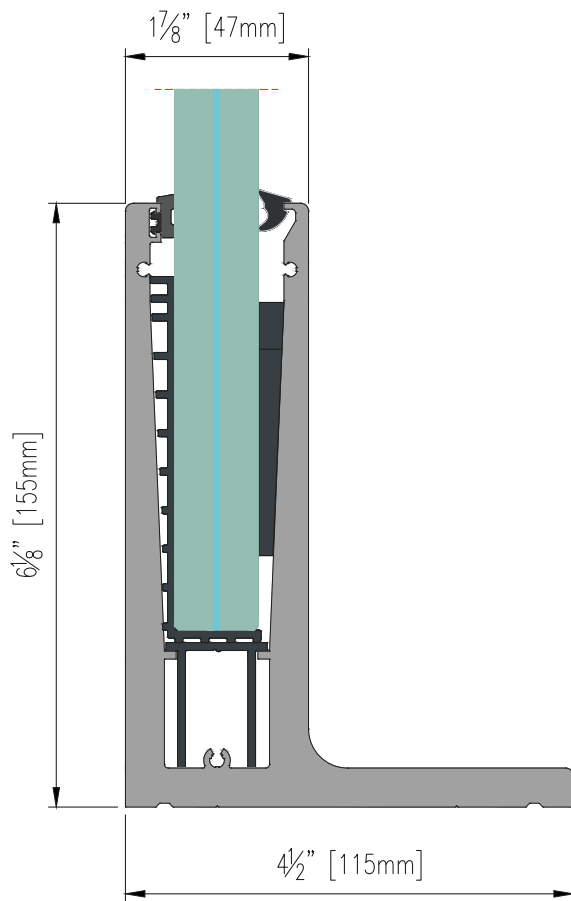

### FEATURES:

- Simplified assembly process
- Clean, streamlined aesthetics
- Capability to position balustrade at a 90° angle
- Hassle-free installation and upkeep



### TECHNICAL PARAMETERS:

- Maximum Panel Height: **3.6ft (1.1 m)**
- Maximum Panel Width: **Unlimited**



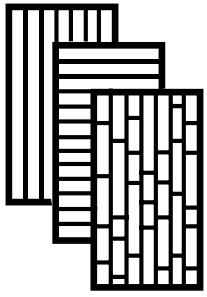

ADD ONS

# LED PROFILE



BRIGHTEN YOUR ENVIRONMENT WITH OUR LED PROFILES. COMBINING AESTHETIC APPEAL WITH TECHNICAL EFFICIENCY, THESE PROFILES ENHANCE THE LOOK AND FEEL OF YOUR DOORS AND WINDOWS, ADDING A TOUCH OF ELEGANCE.



MOREVIEW WITH LED

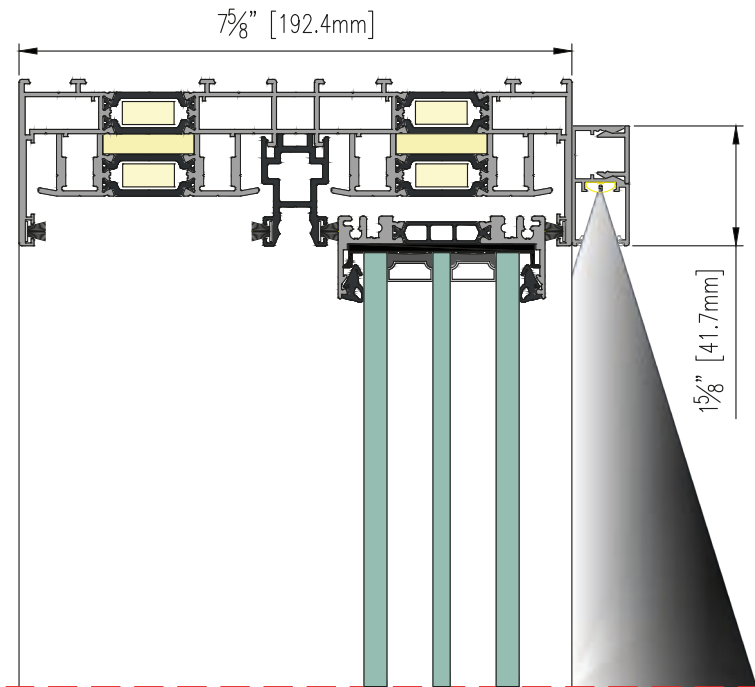

PERFORMANCE TM 77  
DOOR WITH LED OUTSIDE

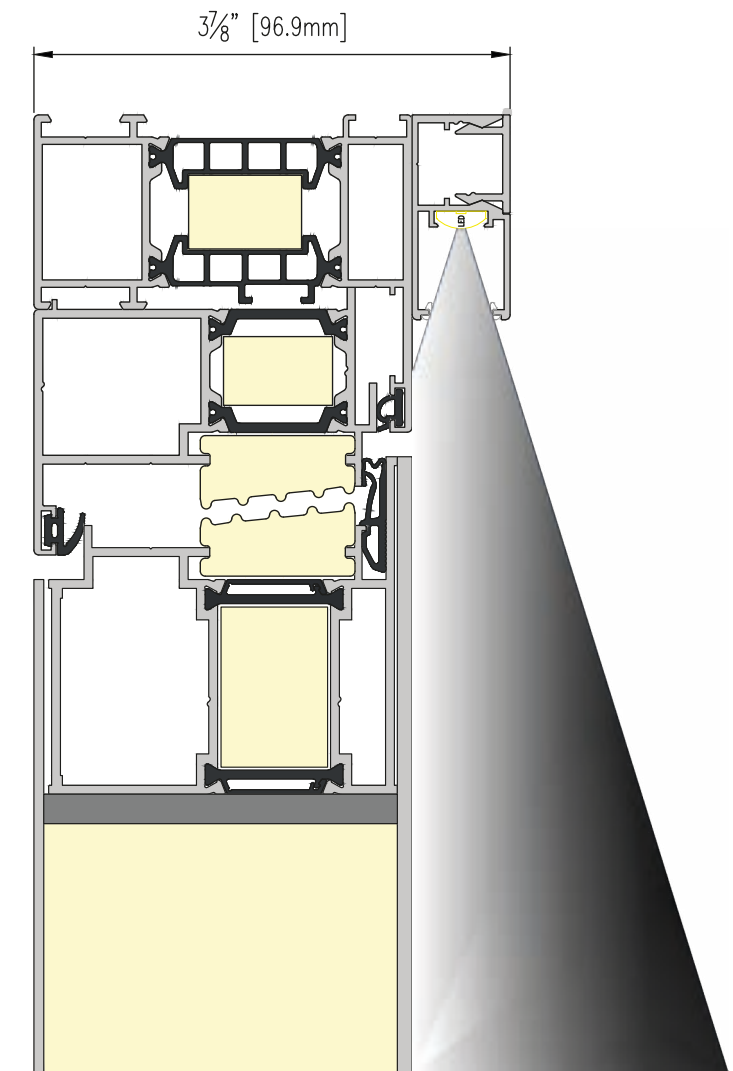

FEATURES:

- Compatible to window, door, sliding system and curtain walls.
- Unlimited design flexibility in crafting entrance doors using the panel door system.
- Efficient and straightforward installation process.
- Clean design lines ensured by adhesive corner connections.

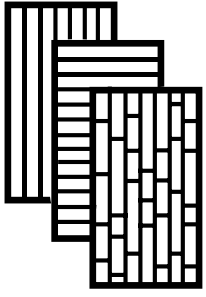

ADD ONS

# ECLIPSE 33



OFFERING A STYLISH AND PRACTICAL ALTERNATIVE TO TRADITIONAL WOODEN OPTIONS, ECLIPSE 33 SHUTTERS-AVAILABLE IN PANEL AND FIXED LOUVRE VERSIONS -ELEGANTLY PROTECT RESIDENTIAL INTERIORS FROM EXCESSIVE SUNLIGHT WHILE ENHANCING BUILDING FACADES.





ECLIPSE 33  
FLAP PANEL

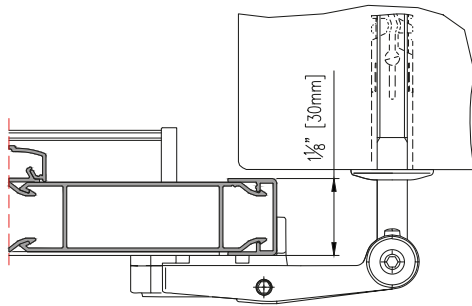
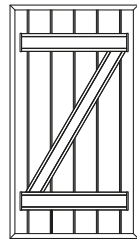

ECLIPSE 33  
PANEL SHUTTER

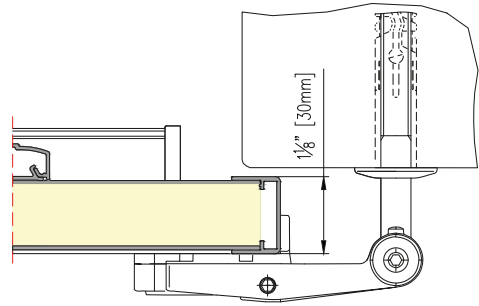
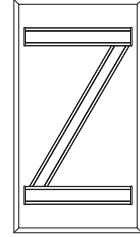

ECLIPSE 33  
SECTION

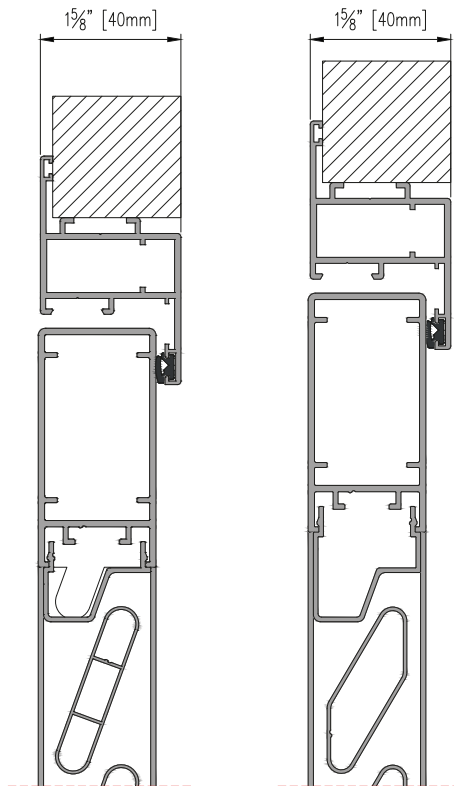

ECLIPSE 33  
FIX LAMELLAR

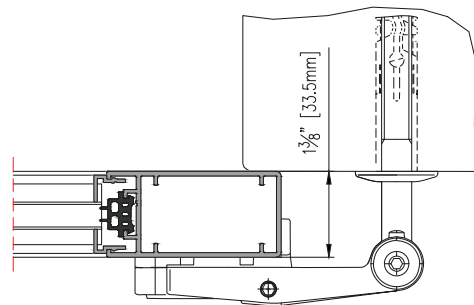
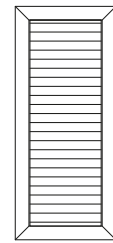

## FEATURES:

- Italian style window shutters
- Oversized dimensions
- Maintenance free
- Unlimited color option
- Complete blackout effect



## TECHNICAL PARAMETERS:

- Maximum Panel Height: **7ft**
- Maximum Panel Width: **7ft**



ADD ONS

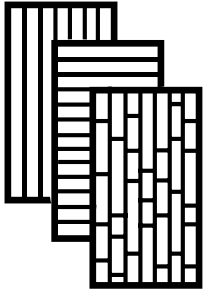

ADD ONS

# LINEAR DRAINAGE

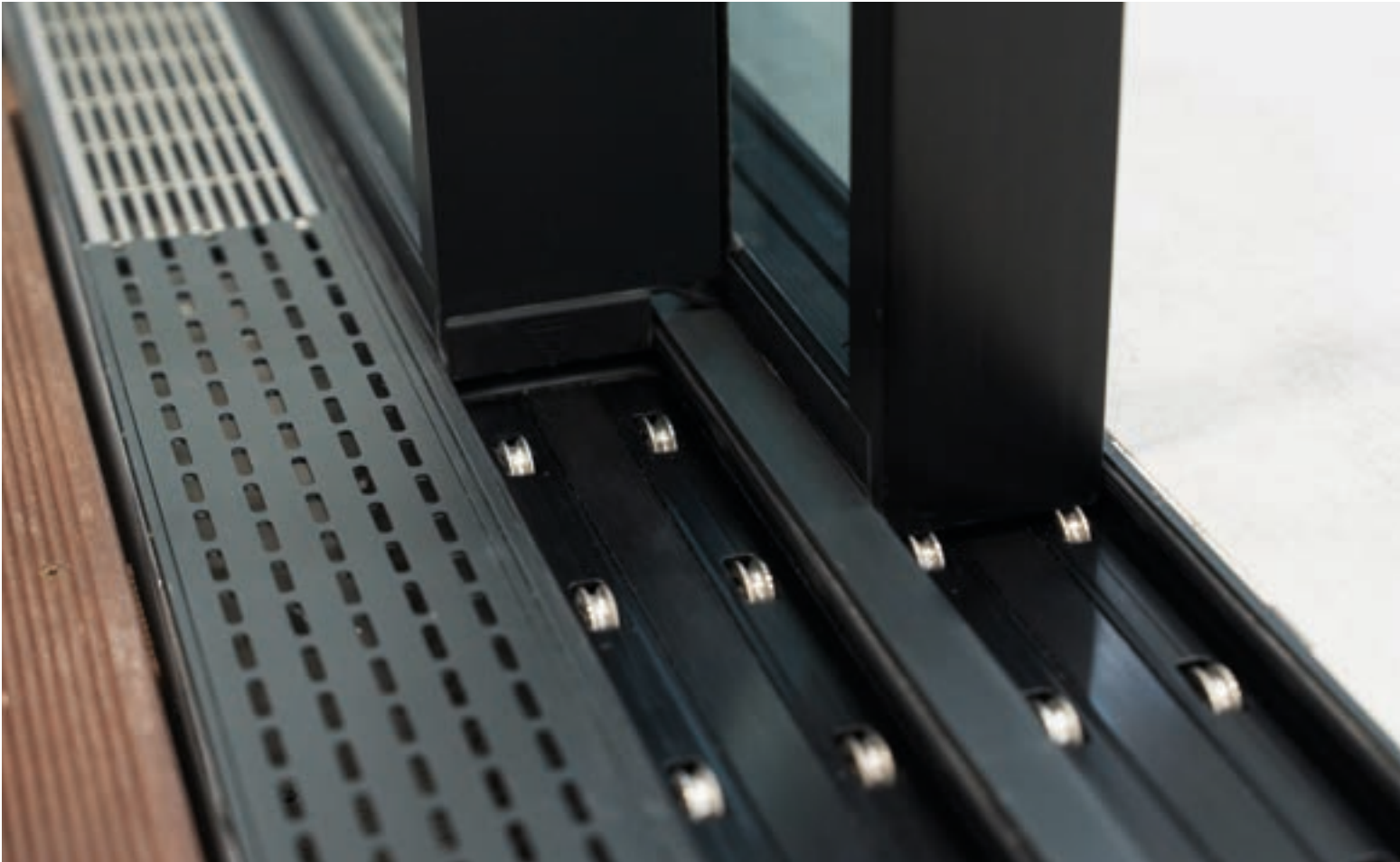

LINEAR DRAINAGE SYSTEMS, INSTALLED LEVEL WITH THE FLOOR, EFFICIENTLY MANAGE WATER EXPULSION SOLUTION.



PERFORMANCE LIFT'N'SLIDE  
WITH LINEAR DRAINAGE

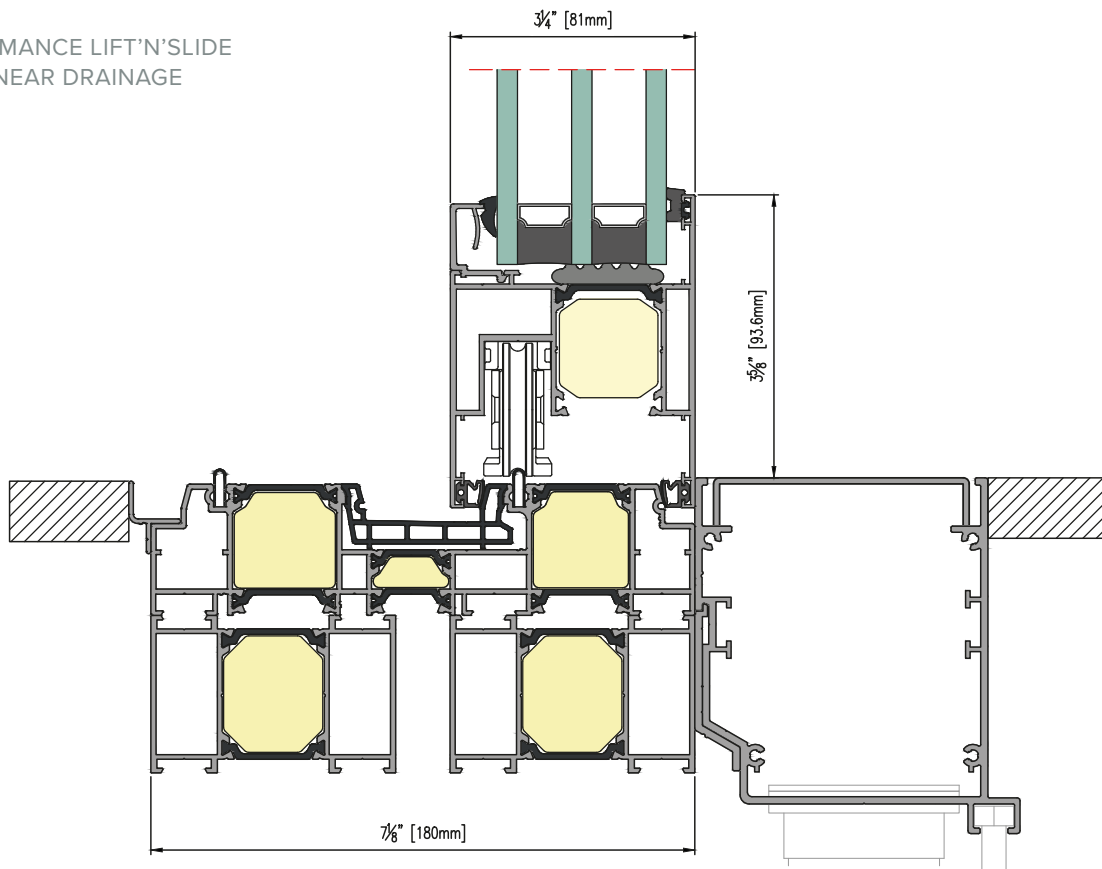

MOREVIEW SLIDER WITH LINEAR DRAINAGE

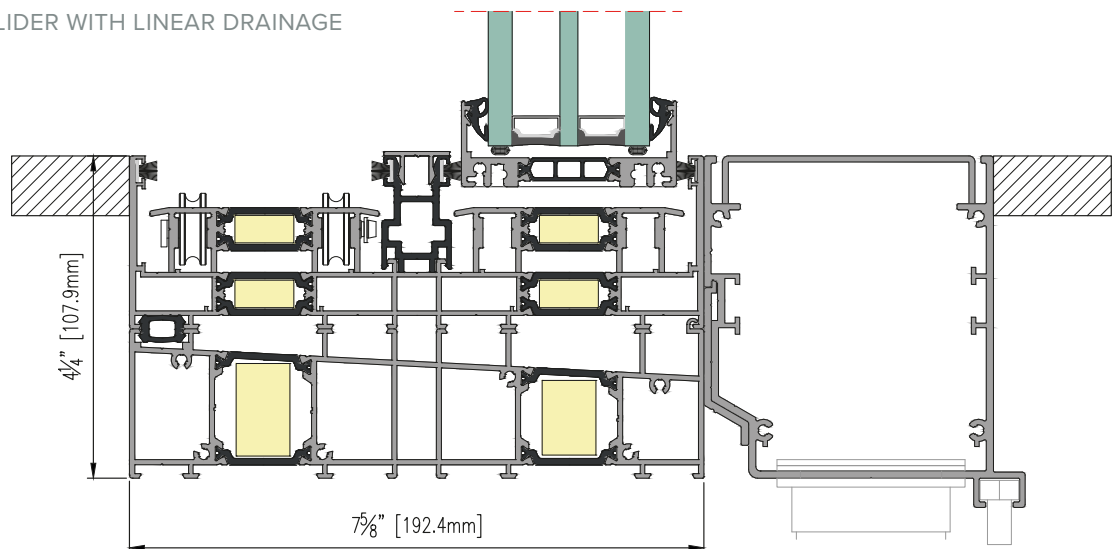

FEATURES:

- Incorporates floor-level guttering for effective condensate drainage
- Facilitates customizable gutter shaping
- Frame-integrated for enhanced stability and durability
- Inclined wall design ensures gravitational condensate outflow
- Compatible with Yawal systems: Moreview, Pano Lift'N'Slide, Prestige, Pano, Passive
- Features an aesthetically pleasing perforated INOX metal sheet



ADD ONS

# CONTACT US

HERE IS WHERE YOU CAN START THE CONVERSATION FOR MORE INFORMATION:

## YAWAL USA

11 West Hudson Ave.  
Englewood, NJ 07631

+1 (551) 250 3614

[office@yawalusa.com](mailto:office@yawalusa.com)  
[estimates@yawalusa.com](mailto:estimates@yawalusa.com)  
[support@yawalusa.com](mailto:support@yawalusa.com)



Visit our website  
[WWW.YAWALUSA.COM](http://WWW.YAWALUSA.COM)







**YAWAL USA**

11 WEST HUDSON AVE.  
ENGLEWOOD, NJ 07631

TEL: +1 (551) 250 3614

E-MAIL: [OFFICE@YAWALUSA.COM](mailto:OFFICE@YAWALUSA.COM)