

ART CATALOGUE



2025



MALWANDLA
ART GALLERY



MALWANDLA
ART GALLERY

ART
CATALOGUE
2025

RELEASED FEB 2026

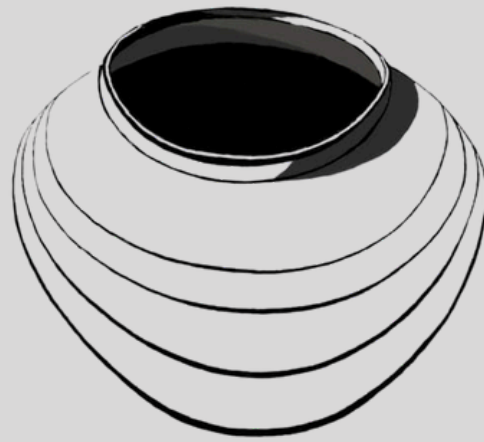

MALWANDLA
ART GALLERY



Malwandla Art Gallery PTY Ltd
2025/113019/07
info@malwandlaartgallery.com

**NOT JUST AN ART GALLERY
BUT OUR GALLERY!**

DISCLAIMER

The Content in this document is issued under Authorised guidance and clearance terms by concerned parties stated below, therefore any alterations, exploitation and right of ownership shall be observed under prior formal agreement(s).

The Concerned Parties in accordance to the aforementioned statement are:

- Malwandla Art Gallery
Malwandla Art Gallery PTY Ltd
Company Reg.: 2025/113019/07
Republic of South Africa
- Faneloeuville Arts Group
Faneloeuville Arts PTY Ltd
Company Reg.: 2021/155343/07
Republic of South Africa
- Ci Prospective
Ci Prospective PTY Ltd
Company Reg.: 2024/610097/07
Republic of South Africa

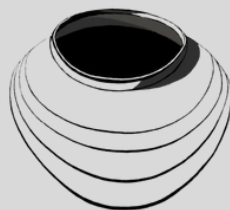

MALWANDLA
ART GALLERY

FEATURES



CONTRA FAIR JOBURG
30 AUGUST 2025

CONTENTS

THE EXHIBITION

09.10

THE ARTIST

11.12

THE COLLECTION

13.44

OUR GALLERY

45.48

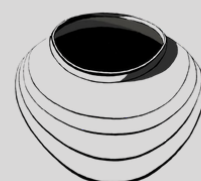

MALWANDLA
ART GALLERY

CATALOGUE

09

THE EXHIBITION

11

THE AUTHOR

13

THE COLLECTION

45

OUR GALLERY



A SOLO JOURNEY WITH MANY OF US



Fanelo
Visual Artist

SOLO EXHIBITION

THE EXHIBITION

A SOLO JOURNEY WITH MANY OF US

A Solo Journey with Many of Us (2025), is an introductory Solo exhibition created by Fanelo Euville Rikhotso, a self taught emerging professional artist.

The title of the exhibition 'A Solo Journey with Many of Us', drives the inspiration behind the collection of Artworks and reflects on the My Journey and the influential relations I had or have with people, locations and boundaries of expression which has paved way to this compilation of artefacts.

The exhibition consist of an artefact collection including Canvas Paintings, Oil Pastels on Mixed Media Paper and Digital Abstract Artworks.

Fanelo Euville Rikhotso

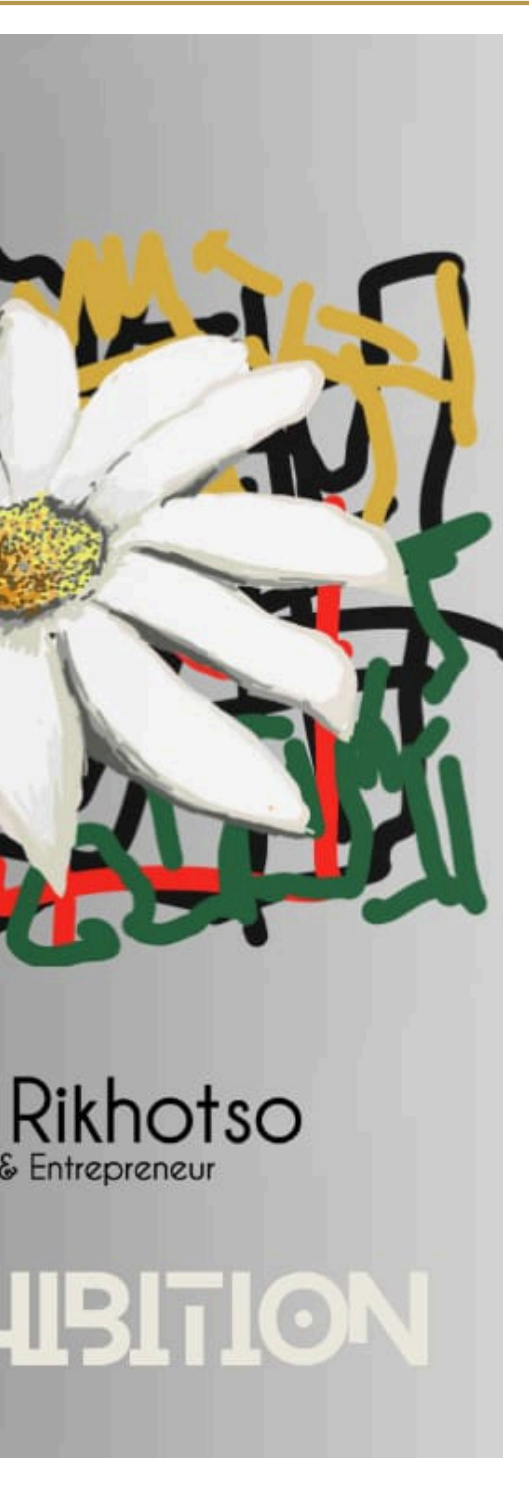

THE ARTIST



THE ARTIST

Artist Biography of Fanelo Euville Rikhotso

I am a visual artist captivated by the stories we have to tell. My work is made out of multiple paper-based mediums - Embracing the relatable stories and perspectives we share.

My process is intuitive and uses blending techniques. I begin with selecting a reference (either an image or a setting) Linking the stories with connected references. With the mediums I use (either being Graphite, Charcoal, Acrylic, Pastel, Aquarelle, Coffee or Oils), I mainly apply a blending technique on my artworks. The feel I aim to achieve with my work is more of a unique touch and a blend of color, holistically an Artwork which evokes a story from the observer's perspective(s)

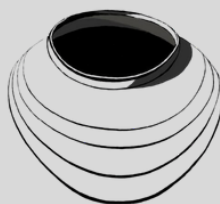

MALWANDLA
ART GALLERY



MALWANDLA
ART GALLERY

THE COLLECTION



*A Solo Journey with Many of
Us*

Artist: Fanelo Euville

Rikhotso

Year: 2025

The Collection consist of a Oil Pastels Artwork Collection, Acrylic Painting Collection and Digital Artwork Collections.

All the Collections reference a storyline which reflects the Artist Journey in becoming an Visual Artist.

The Oil Pastels Artwork reflect on a snapshot storyline related to the Artist [Fanelo] childhood upbringing. The reference Settings of the Storyline is in Soweto and Giyani.

Acrylic Painting Collections storyline references the aforementioned settings, and the story expressed with a blending and Impressionism feel.

The Digital Collection briefly focuses more on the Artists relational thought with the Storyline.



MALWANDLA ART
GALLERY



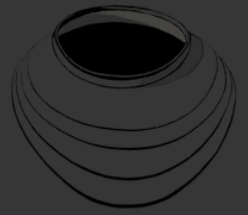

MALWANDLA
ART GALLERY

OIL PASTEL COLLECTION



MALWANDLA ART
GALLERY

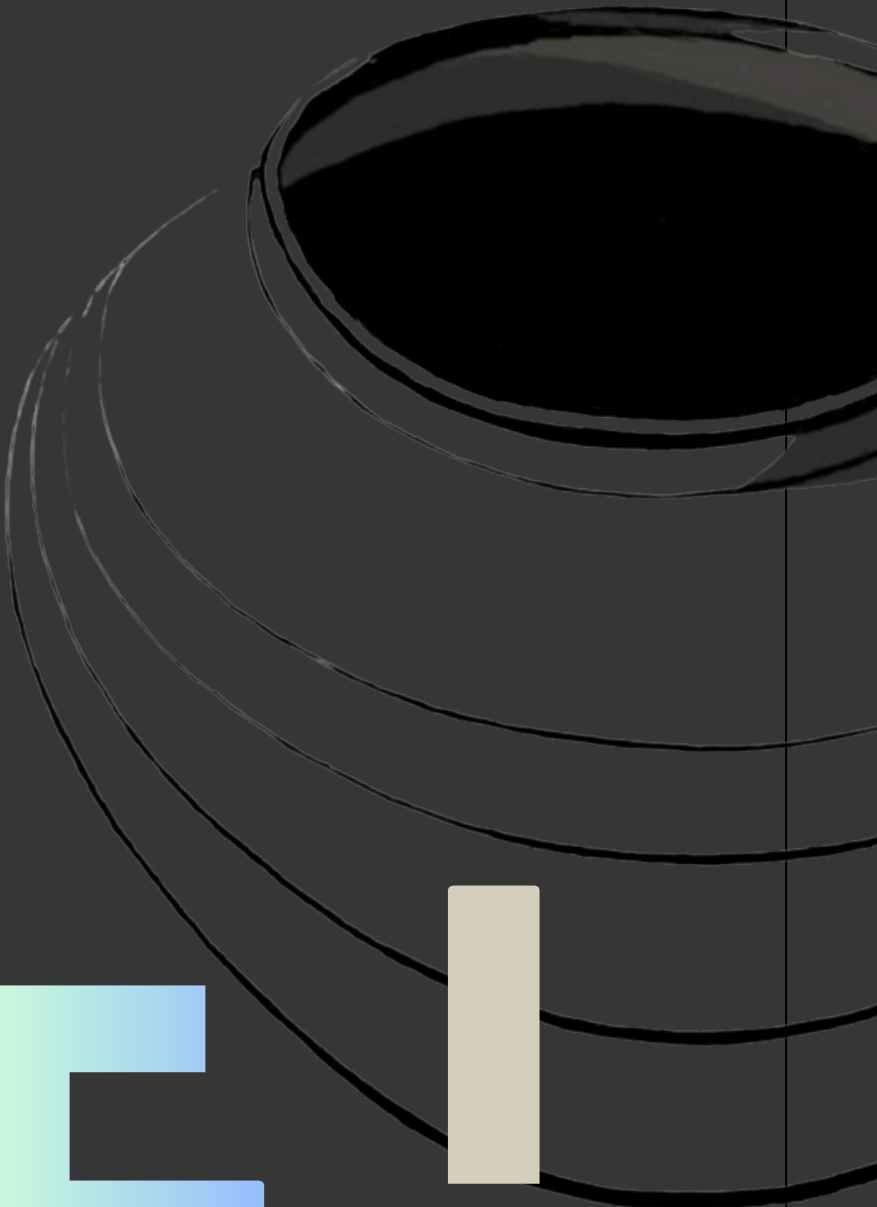

S **T** **E** **!**



Hope Street

Fanelo Euville Rikhotso

2025

Oil Pastels Artwork done on a Mixed Medium Paper (42.0cm x 54.4cm), Pastels stroke techniques applied: Light and Heavy Blending, Scumbling, Colour Mixing, Sgraffito and Stippling.

R 19000.00



Hope Street

Hope Street is about a strive to keep hope alive in a reality which is contradictory,

the reference settings of the Artwork is outsourced from Photographer, Siyabonga Mongwe, who is based in Soweto. That adaptation of the work stems from its relevance in depicting a phenotypical representation of a steadfast hope through a storm of uncertainty.

Amidst with the intoxication of bad choices, a yearning for freedom of choice, a life of freewill and a place to call home, there's a believe to bear a new beginning.

In this world one either gives in to misfortune, or oughts to put on a strong face of pride, an attire of rebellion and stride of a finale.

Artist's Inspiration

What is inspired me to adapt and recreate the Hope Street artwork, it is reminiscent memory which is predominant, from my township upbringing and experience grow up in Meadowlands, Soweto.

Reference Credit

Siyabonga Mongwe
Photographer

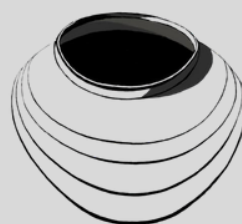

MALWANDLA
ART GALLERY

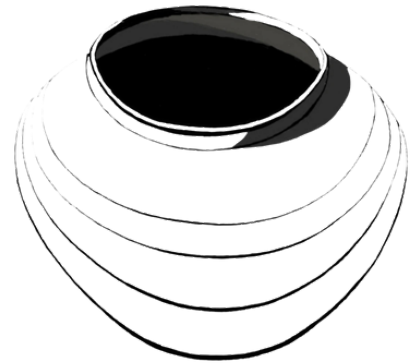

Platform 03

Fanelo Euville Rikhotso

2025

Oil Pastels Artwork done on a Mixed Medium Paper (42.0cm x 54.4cm), Pastels stroke techniques applied: Light and Heavy Blending, Scumbling, Colour Mixing, Sgraffito and Stippling.

R 18000.00

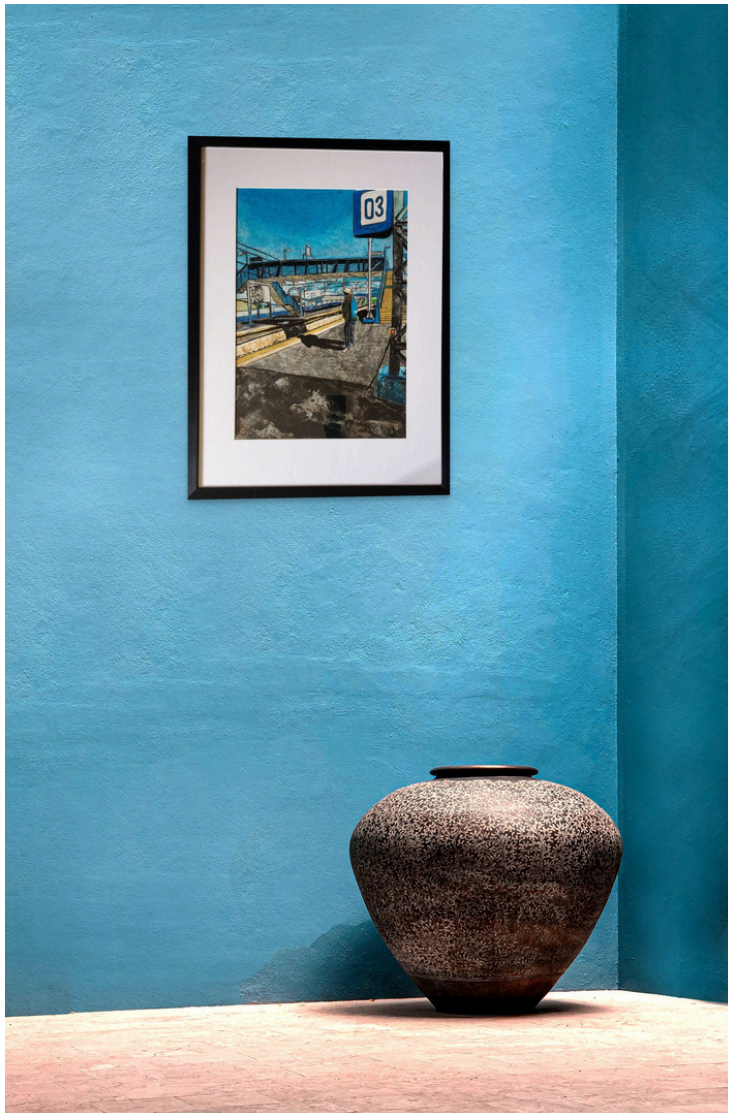

Platform 03

The Platform 03 Artwork give its recognition to a forgettable yet permanent feature of a journey of hope, fulfilment, test and grief.

Trips though a motion of time with faces of book covers, stories of relatable sips and a common destination with a discriminatory forecast.

Each way for its own, each find for its keep, for the rails have kept going and the platform remained an opened letter.

Artist's Inspiration

While taking a trip on my daily commute, i had a moment to rest and take a moment to be fully aware of what's around me, then I realised a sight of bridge above the train tracks and I imagined myself positioned along platform. And there a came a thought said... it's a perfect reference to work with, so I gave it a try.



MALWANDLA
ART GALLERY

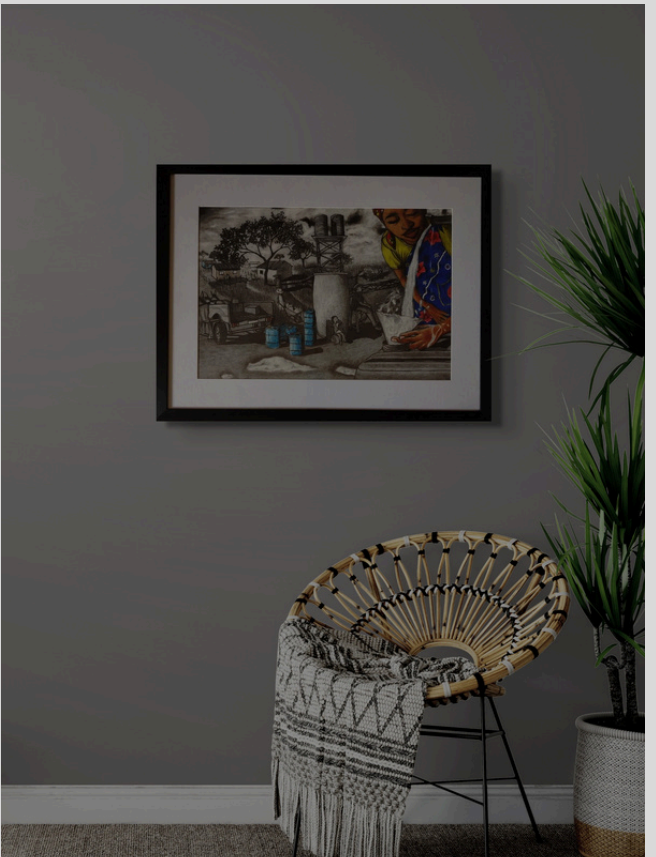

Homeland Refill

Fanelo Euville Rikhotso

2025

Oil Pastels, Aquarelle Pencil and Graphite Artwork done on a Mixed Medium Paper (42.0cm x 54.4cm), Graphite and Aquarelle Blending, Pastels stroke techniques applied: Light Blending and Scumbling.

R 18000.00



Homeland Refill

Homemade Refill for a thirst of life,
above a baking land of arid
tributaries.

What flows is a strong resolve to live a
colourful life.

Artist's Inspiration

A random day to refill water gave me
a wake-up call on how a basic life can
be. Being dependant on ground water
as a water source and having to make
an adjustment to being mindful to give
as I much as I take.

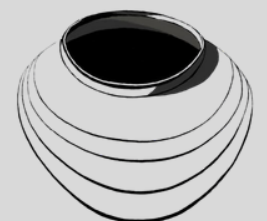

MALWANDLA
ART GALLERY

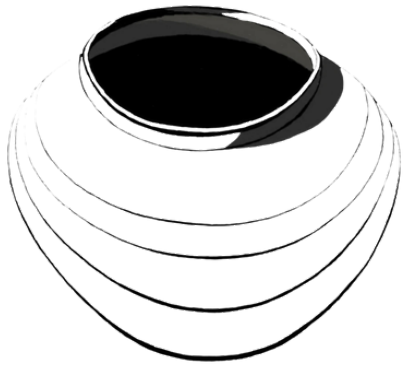

On and Off the Rails

Fanelo Euville Rikhotso

2025

Oil Pastels and Graphite Artwork done on a Mixed Medium Paper (42.0cm x 54.4cm), Graphite Blending, Pastels stroke techniques applied: Light and Heavy Blending, Colour Mixing, Sgraffito and Stippling.

R 17500.00



On and Off the Rails

The Purpose Mission going on about
with intention to a checkpoint
milestone, with an unrelenting pursuit.

Carrying the hopes of many on its rails
and a vow of success of it.

Artist's Inspiration

From a Childhood Exploration, a sight
of wonder and inquisitive recollection
and finally an understanding of
disparities.



MALWANDLA
ART GALLERY

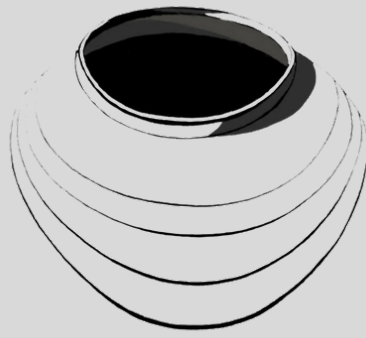

Oil Pastels Artwork and Graphite done on a Mixed Medium Paper (42.0cm x 54.4cm), Pastels stroke techniques applied: Light and Heavy Blending, Scumbling, Colour Mixing, Sgraffito and Stippling.

R 19000.00

Generational Pursuit

Fanelo Euville Rikhotso

2025



Generational Pursuit

The Inheritance of Adaptation and the normalisation of a simulated environment.

A belonging to one and an apparent box to others, either a rest camp or a return from a lost cause war. A generational open letter to whom it may concern.

Artist's Inspiration

The Creation of the Generation Pursuit Artwork was inspired by upbringing experience which I exposed to, and one which I had to come into terms with.

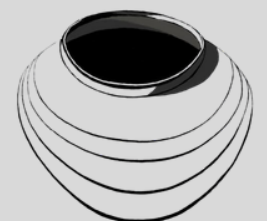

MALWANDLA
ART GALLERY

ACRYLIC PAINTING COLLECTION



ACRYLIC
PAINTING

IC

TINGS

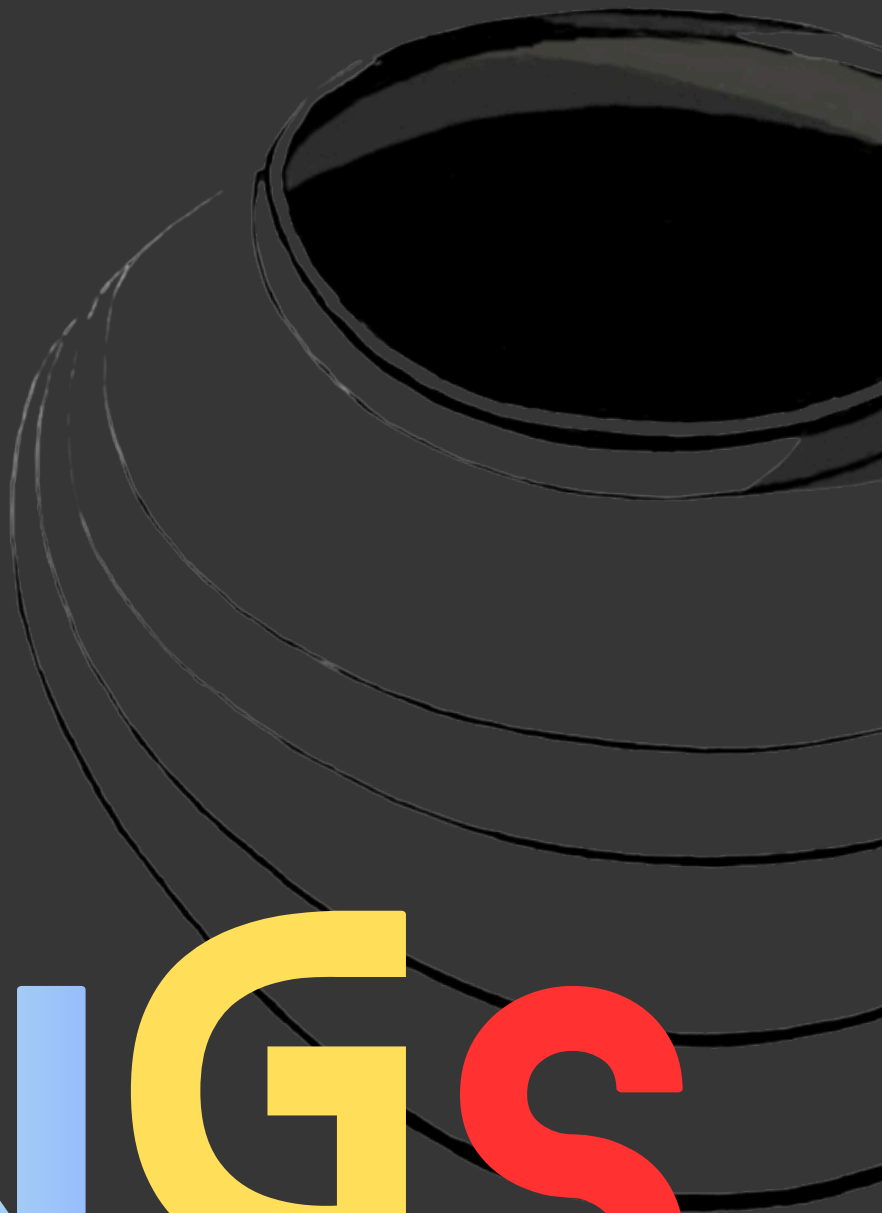



The Field

Fanelo Euville Rikhotso

2025

Acrylic Painting done on a box Canvas (100 cm x 100cm), brush stroke techniques applied: Blending, Dry Brush, Impressionism and Wash.

R 8000.00



This is not just a field, but a sacred location for a gathering of raw faithfuls with aspirations beyond their Wildest dreams.

Some refer to its as 'eTafuleni' (At the table) with reference to the biblical Psalms 23 - The Lord Shall prepare my table before my enemies.

Artist's Inspiration

A soccer field a key feature, with a rich tradition of grassroots soccer and emerging talent across various townships.

Reference Credit

Pitsi Paulus Vincent Matlou
Sports Photographer (Vino Snap)

The Field

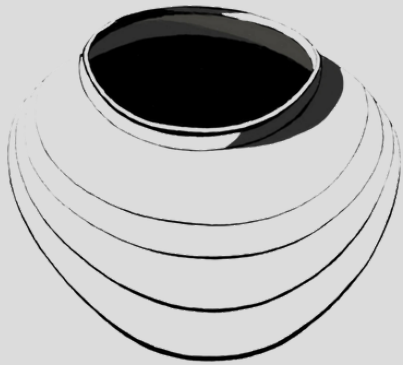

A Calm Place

Fanelo Euvile Rikhotso

2025

Acrylic Painting done on a box Canvas (100 cm x 100cm), brush stroke techniques applied: Blending, Dry Brush, Impressionism, Wash and Radiating.





A Calm Place

A place to fill a conflicted void, to
ease the tension of thoughts, to
cushion a pounding heart.
A Calm Place.

Artist's Inspiration

A Homage to the Homeland wealth of
tranquil scenery and elements of life.

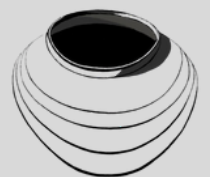

MALWANDLA
ART GALLERY

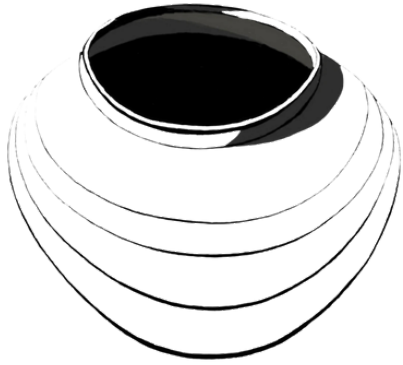

A Breakground of Home

Fanelo Euville Rikhotso

2025

Acrylic Painting done on a box Canvas (100 cm x 100cm), brush stroke techniques applied: Blending, Dry Brush, Impressionism and Wash.

R 40000.00



A Background of Home

A rooted grounding, A belonging of one to many, a hold of strength, a background of Home.

Artist's Inspiration

A Homage to my cultural Homeland, tradition and customs (*Vatsonga*).



MALWANDLA
ART GALLERY

DIGITAL ARTWORK COLLECTION



D I G I T
A R T W

AL

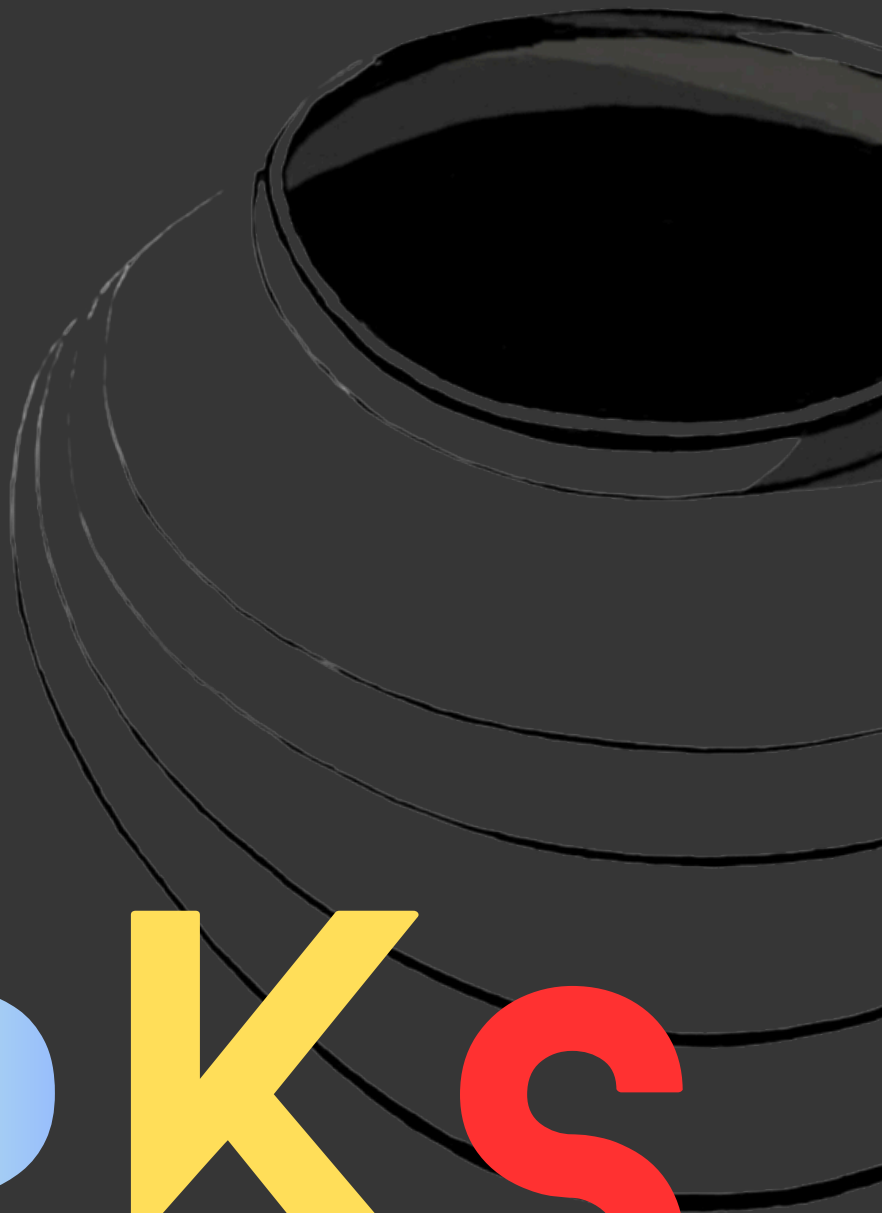

ORKS

PRINTING STAKEHOLDERS

MARKETPLACE



PROPERTY OF STUDIO

ART PRINTING



PRICELIST STRUCTURE

Available Paper and Prices

- Baryta paper 325gsm

Printing Surface Size	Print Retail Price
A4 (21cm x29.7cm - 25x25)	R2000.00
A3 (29,7cmx42cm - 36x36)	R3500.00
A2 (42cmx59,4cm - 50x50)	R6500.00
A1 (59,4cmx84,1cm - 72x72)	R11500.00
A0 (84,1cmx118,9cm)	R22000.00

- Cotton Rag papers 310gsm

Printing Surface Size	Print Retail Price
A4 (21cm x29.7cm - 25x25)	R2000.00
A3 (29,7cmx42cm - 36x36)	R3500.00
A2 (42x59,4 - 50x50)	R6500.00
A1 (59,4x84,1 - 72x72)	R11500.00
A0 (84,1x118,9)	R22000.00

- Matt paper Studio 235gsm

Printing Surface Size	Print Retail Price
A4 (21x29.7 - 25x25)	R1700.00
A3 (29,7x42 - 36x36)	R3200.00
A2 (42x59,4 - 50x50)	R5800.00
A1 (59,4x84,1 - 72x72)	R11000.00
A0 (84,1x118,9)	R21000.00

- Pandora Canvas 380 gsm

Printing Surface Size	Print Retail Price
A4 (21x29.7 - 25x25)	R1800.00
A3 (29,7x42 - 36x36)	R3400.00
A2 (42x59,4 - 50x50)	R6300.00
A1 (59,4x84,1 - 72x72)	R12000.00
A0 (84,1x118,9)	R23000.00

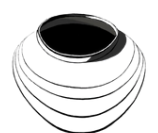

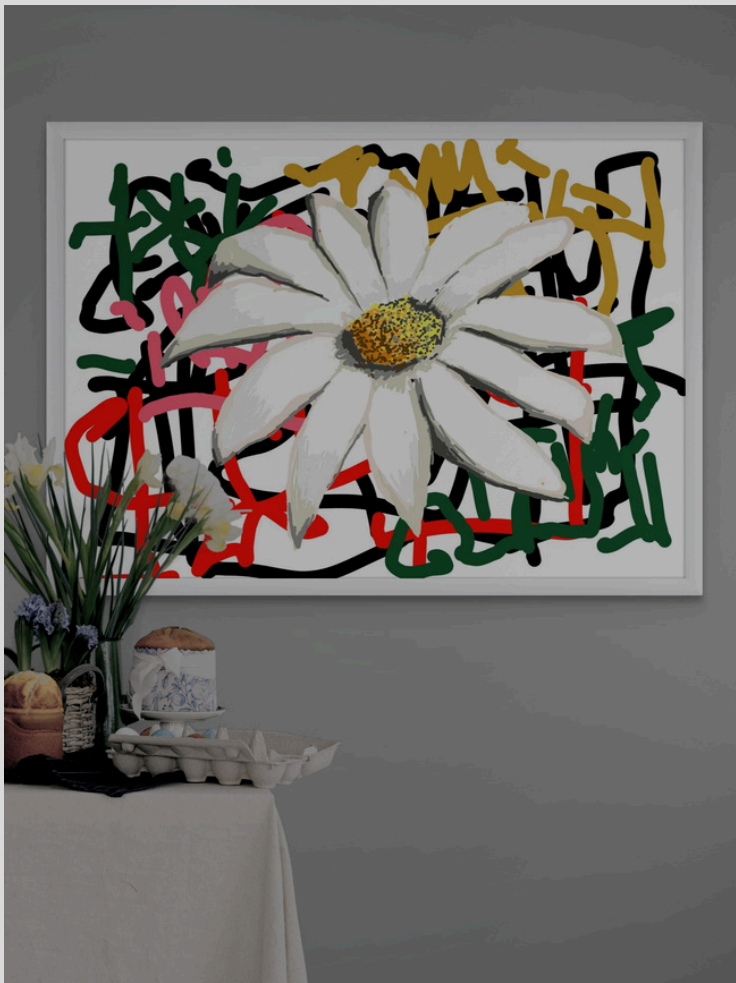
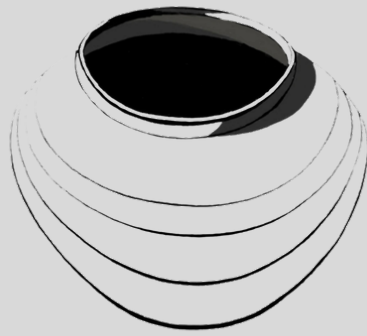

Daisy Abstract (Digital Art)

Fanelo Euville Rikhotso

2025

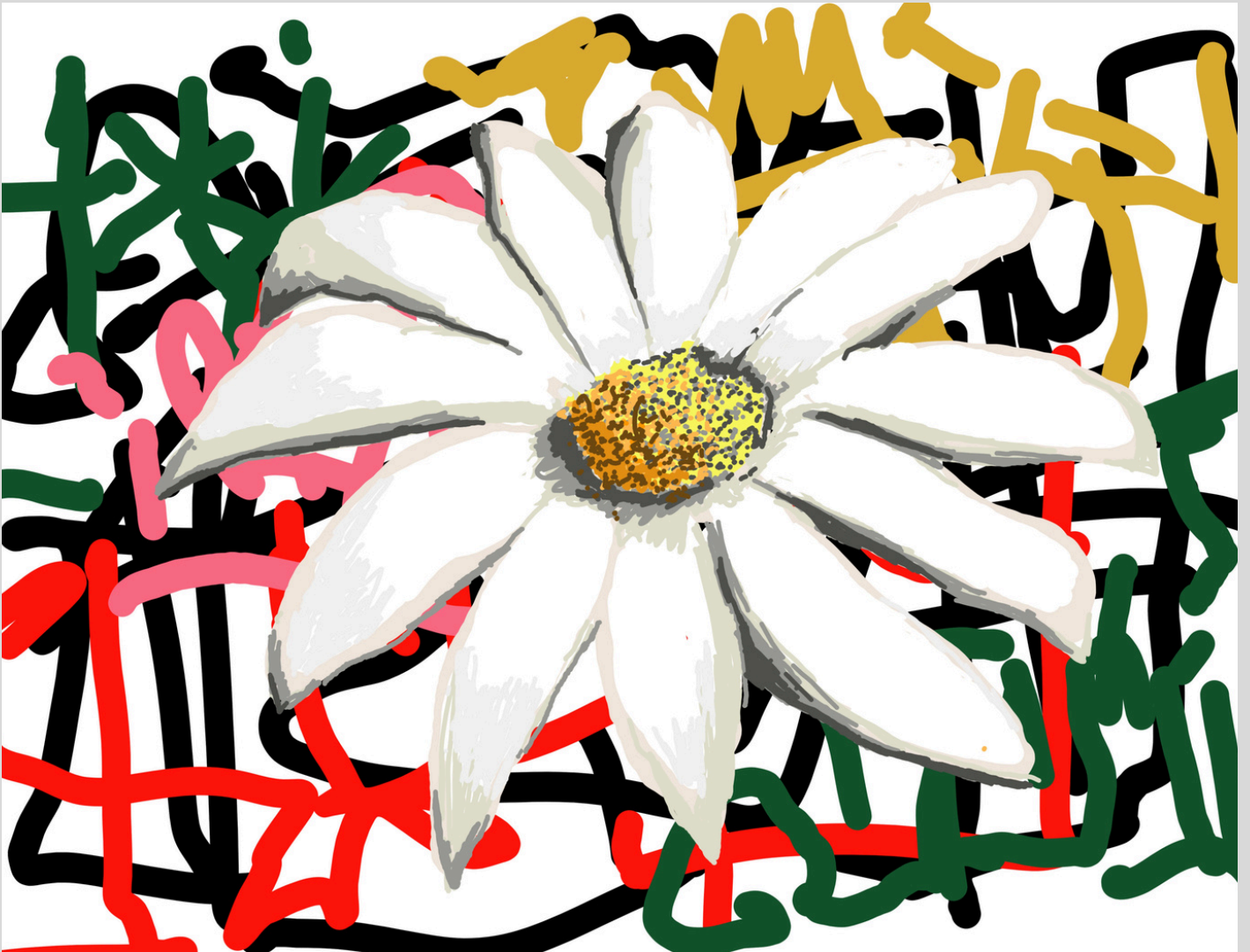

Flower

Art Medium: Digital Painting
Collection: A Solo Journey with Many of Us
Year: 2025

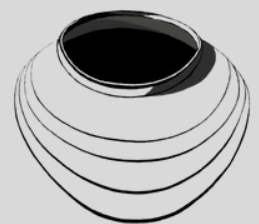

MALWANDLA
ART GALLERY

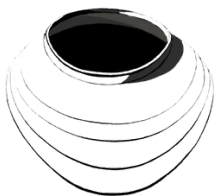

Calabash Abstract (Digital Art)

Fanelo Euville Rikhotso

2025



Abstract Calabash

Art Medium: Digital Painting
Collection: A Solo Journey with Many of Us
Year: 2025



MALWANDLA
ART GALLERY

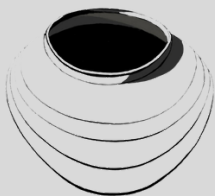

**The Three Foot Pot Abstract
(Digital Art)**

Fanelo Euville Rikhotso

2025

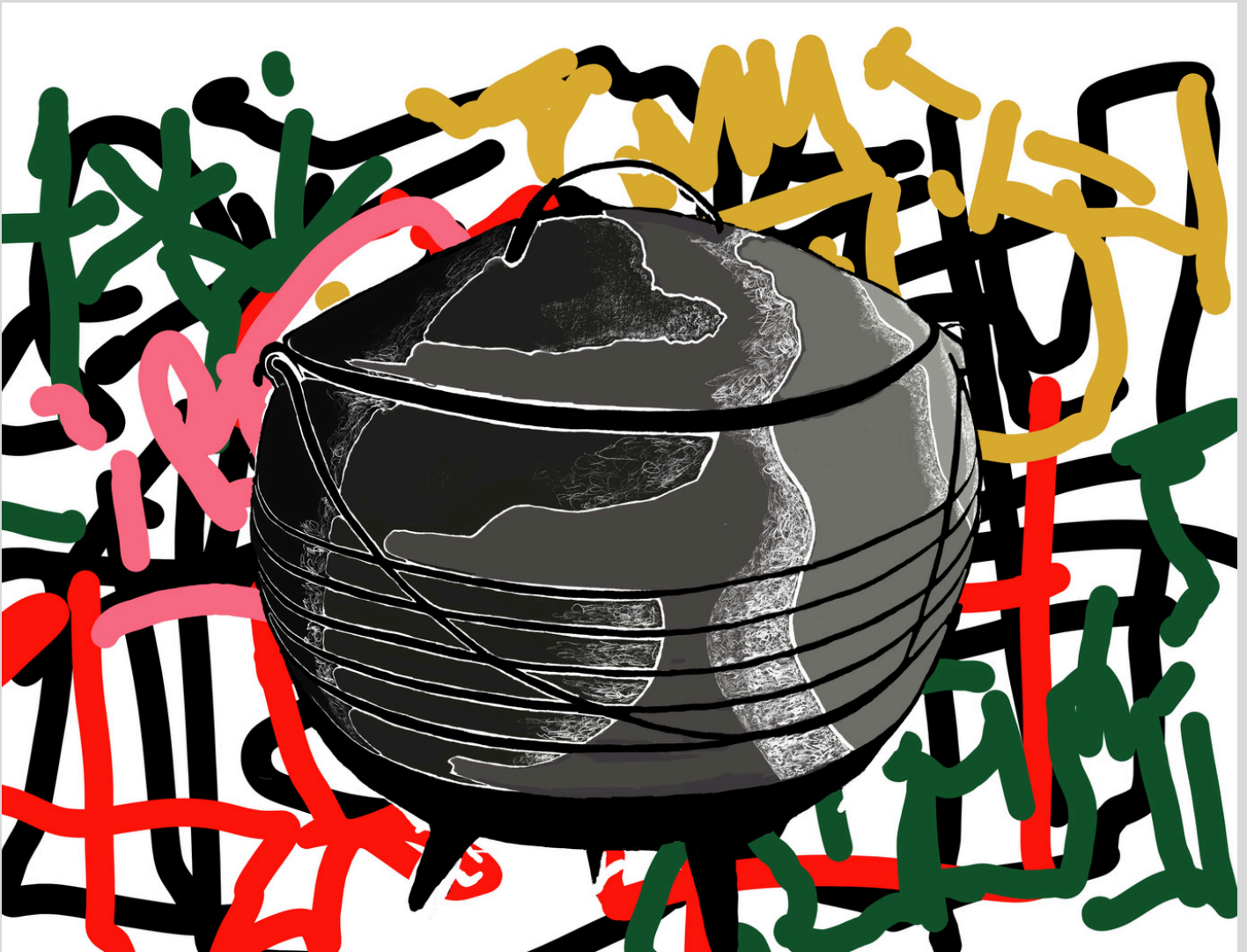

Three Foot Pot

Art Medium: Digital Painting
Collection: A Solo Journey with Many of Us
Year: 2025

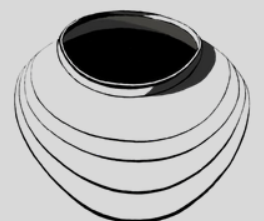

MALWANDLA
ART GALLERY

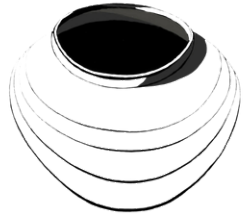

OUR GALLERY

OFFICIAL PLATFORMS

Original African Art | Original African Gallery



SUBSIDIARY
COMPANY OF
FANEL-ŒUVILLE
ARTS GROUP



MALWANDLA
ART GALLERY



WEBSITE

www.malwandlaartgallery.com

OFFICIAL EMAIL



info@malwandlaartgallery.com

SOCIAL PLATFORMS



[@malwandlaartgallery](https://www.instagram.com/malwandlaartgallery)

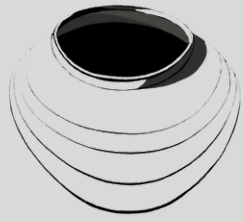

OUR GALLERY

VIRTUAL GALLERY PLATFORM

Original African Art | Original African Gallery

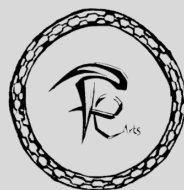

SUBSIDIARY
COMPANY OF
FANEL-ŒUVILLE
ARTS GROUP

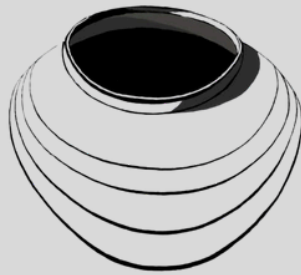

MALWANDLA
ART GALLERY

VIRTUAL GALLERY

Our Virtual Gallery Platform brings to life our exhibition settings. Affording our visitors a realistic experience and observation of Artworks on a Gallery viewing.

VIRTUAL GALLERY STAKEHOLDER

ARTPLACER 

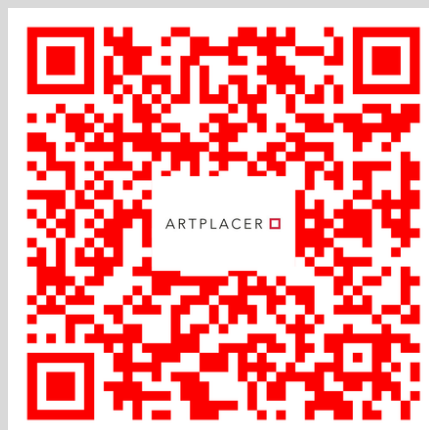

INKOMU



FAMELEDEUVILLE
ARTS GROUP



MALWANDLA
ART GALLERY



MALWANDLA
ART GALLERY

MALWANDLAARTGALLERY.COM