

The Angle-Rite® Miter/Notcher Cutting Attachment

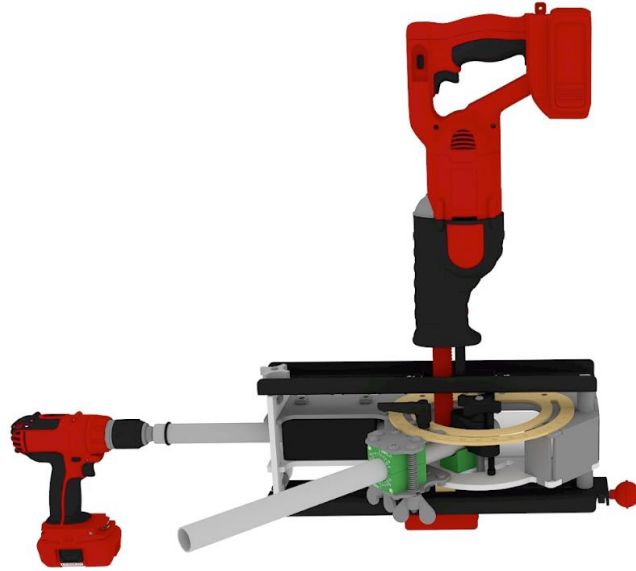

Notching

Adjusting the bearing housing

The bearing housing is normally adjusted to notch on the center line of the tube. When you receive the Miter/Notcher, the factory setting for the bearing housing uses the red steel shim along with the 0.020" shim. If it is not cutting on the center line, add or remove shims until center line cutting has been established.

Adjust the depth of the notch into the end of intersecting tube by loosening the four bottom bolts and moving the housing by turning the socket head screw (located on the side of the housing) in or out. After adjusting, re-tighten the four bottom bolts.

The secondary clamp determines the depth of the notch produced by the hole saw into the tube. The 0° mark on the secondary clamp angle guide is the normal desired depth. When the secondary clamp holding the notched tube is reattached to the primary clamp, the notched tube will fit to the intersected tube with minimal gap at the joint.

Attaching the hole saw

You can attach the hole saw to the shaft through a variety of methods.

- Smaller hole saws with a 1/2"-20 threads require an adapter that reduces the thread size. Thread a 1/2"-20 setscrew into the adapter and then the hole saw onto it.
- Attach larger hole saws by threading a 5/8"-18 set screw into the end of the shaft, and then threading the hole saw onto the setscrew protruding from the end of the shaft.
- An option for larger hole saws, is to use a specific type of arbor that can be threaded into the shaft. This can be used to eliminate the strain on the hole saw threads by utilizing the pinholes found on larger hole saws. Please inquire if you need a compatible whole saw arbor.

Notching Procedure:

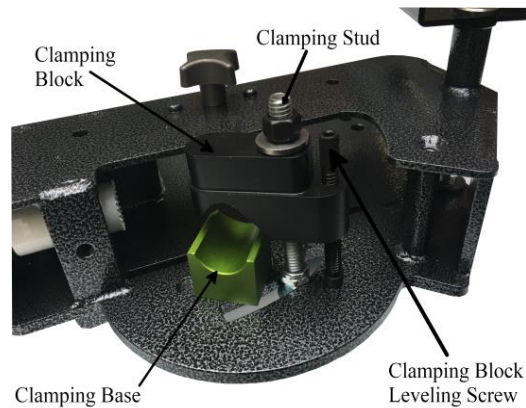

1. Attach the appropriate hole saw to the end of the shaft.
2. Find the appropriate clamping base that matches the tube diameter and place the bottom pin into the short slot on the frame of the cutting attachment.
3. Place the secondary clamp (with tube) onto the frame at the same time allowing the clamping base to align under the tube.
4. Place the clamping block onto the clamping stud and over the tube. Adjust the leveling screw on the end of the clamping block until the top of the block is horizontal (i.e. parallel to the frame of the cutting attachment.)
5. Place a washer and nut onto the clamping stud and tighten the clamping block until the tube is firmly held in place.
6. Use an electric drill to slowly advance the hole saw through the tube, using the appropriate RPM for your cutting conditions.
7. The tube and secondary clamp components may now be removed.

When done cutting, the loose angle guide can be replaced by using the angle stop as a gauge, indexing the known angle or, you can use the straight sides of the angle guides to align them to each other using a flat surface.

Miter cutting

Before using the miter attachment, make sure the shaft used for the hole saw notching is not able to slide out of the bearing housing. Allowing cutting chips into the bearing housing will damage the bearings. Threading a hole saw larger than 1" diameter, or a nut & washer onto the protruding threads can be used to prevent the shaft from sliding out of the housing.

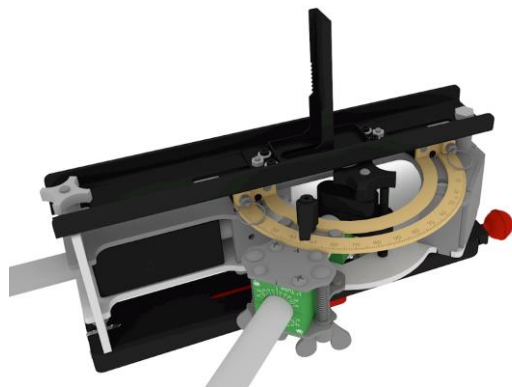

The miter attachment has two tracks - one above and one below the cutting area. The upper track has a sliding car fit with the reciprocating saws pivot shoe. *(If not installed, attach the pivot shoe onto the sliding car with the 4 fasteners & washers making sure the saw, when attached, cuts from left to right.)*

The lower track has a car that is spring-loaded and has adjustable blade guides for the saw blade.

The lower car has a shaft & ball knob attached and is used to slide the blade guide car to the start of the cut. It is also useful for making sure the blade guide is moving while cutting.

When mounting the secondary clamp to a cutting attachment, one of the angle guides must first be removed. Make note of the angle setting or push the angle guide stop against the clamp half guide plate and tighten. Unscrew the angle adjusting lever and set loose angle guide aside.

Miter Cutting Procedure:

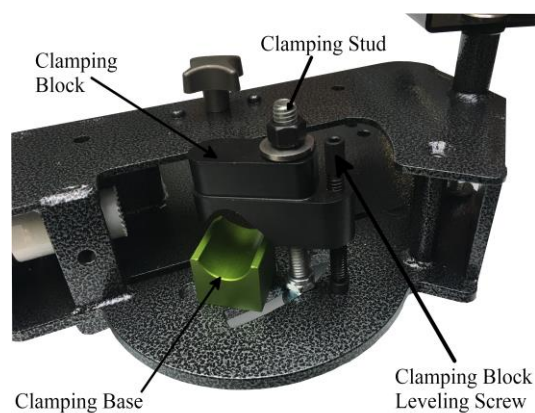

1. Find the appropriate clamping base that matches the tube diameter and place the bottom pin into the short slot on the frame of the cutting attachment.
2. Place the secondary clamp (with tube) onto the frame at the same time allowing the clamping base to align under the tube.
3. Place the clamping block onto the clamping stud and over the tube. Adjust the leveling screw on the end of the clamping block until the top of the block is horizontal (i.e. parallel to the frame of the cutting attachment.)
4. Place a washer and nut onto the clamping stud and tighten the clamping block until the tube is firmly held in place. The top and bottom tracks should now be rotated into place and the end knobs rotated into place and tightened, before inserting the reciprocating saw.
5. Push the spring-loaded blade guide car in as far as it will go and latch in place using the ball knob. To attach the reciprocating saw, first unplug it from the power source or lock the switch and attach the saw blade.
6. Slide the car with pivot shoe attached to the left end of the top track.
7. Open the pivot shoe release lever on the reciprocating saw and slide the reciprocating saw onto the pivot shoe taking care to align the saw blade between the blade guides on the track below.
8. Tighten the release lever.
9. Release the spring-loaded blade guide using the ball knob on the lower track. Double check that the blade is between the blade guides. The blade guide (with attached shaft & ball knob) should now move in and out when the reciprocating saw is tilted slightly in its pivot shoe.
10. Keep clear of the cutting area. Make the miter cut by powering and slowly advancing the reciprocating saw. The ball knob and shaft should move as you advance the saw through the cut.
11. When you're finished cutting, unplug the power cord or lock the power switch, release the pivot shoe latch and remove the reciprocating saw with blade attached.
12. The top track may now be rotated out of the way and the tube and secondary clamp components may be removed.

When done cutting, the loose angle guide can be reattached by using the angle stop as a gauge, indexing the known angle or, you can use the straight sides of the angle guides to align them to each other using a flat surface.