

THE METAL SHOP

2541 W. Dunnellon Road

Dunnellon, FL 34433

www.metalshop.org

Phone: 888-441-2492 Fax: 352-522-0007

NOTES:

1. ALL CONSTRUCTION SHALL BE IN ACCORDANCE WITH THE 2023 FLORIDA BUILDING CODE, EIGHTH EDITION, BUILDING VOLUME AND ASCE 7 - 2022 MINIMUM DESIGN LOADS ON BUILDINGS AND OTHER STRUCTURES.
2. ANY CHANGE FROM THE DRAWINGS AND / OR FIELD CHANGE CONDITIONS, MUST BE IMMEDIATELY BROUGHT TO THE ATTENTION OF THE STRUCTURAL ENGINEER SO THAT NECESSARY CHANGES CAN BE MADE AND INTENT OF THE DESIGN IS CARRIED OUT TO ITS FULLEST EXTENT.
3. IT IS THE RESPONSIBILITY OF INSTALLING CONTRACTOR TO PROVIDE ADEQUATE ANCHORAGE AND CORROSION RESISTANT ISOLATION PADS AT THE BOTTOM OF ALL BASE PLATES WHEN BEARING ON CONCRETE AND STEEL STRUCTURES.
4. MINIMUM DESIGN LOADS:
DEAD LOADS AND LIVE LOADS ARE IN ACCORDANCE WITH THE 2023 FLORIDA BUILDING CODES, CHAPTER 16.
WALL BRACES FRAMES ARE DESIGNED TO SUPPORT A/C UNITS WITH WIND SPEEDS UP TO 186 MPH PER 2023 FBC AND ASCE 7-22 FOR CATEGORY I AND II BUILDINGS, ONLY UP TO 30 FEET ABOVE GROUND.
FOR ALL OTHER BUILDING CLASSIFICATIONS AND FOR WALL MOUNTING ABOVE 30 FEET SITE SPECIFIC ENGINEERING WILL BE REQUIRED.
5. CALCULATIONS ARE BASED ON TYPICAL A/C CONDENSING UNIT WEIGHTS AND SIZES AS PROVIDED BY MANUFACTURE SUPPLIED DATA. MAXIMUM UNIT WEIGHT IS LISTED IN REACTIONS TABLE ON SHEET 2.
6. DESIGN AND ENGINEERING IS FOR THE METAL SHOP WALL BRACE ONLY. SEE MANUFACTURE INSTRUCTIONS AND CERTIFICATIONS FOR PROPER INSTALLATION OF AC UNIT.
7. SEE MANUFACTURE INSTALLATION FOR AC CONDENSER UNIT.
8. 6063-T5/6061-T6 ALUMINUM ALLOY CONSTRUCTION FOR EXTERIOR EXPOSURE APPLICATIONS.
9. WALL BRACES SHALL HAVE ALL WELDED JOINTS AND SEAMS UNLESS OTHERWISE STATED.
10. WELD FILLER SHALL BE ALUMINUM ALLOY 4043 WITH TENSILE STRENGTH OF 26-28 KSI.
11. ALL ANCHOR/CONNECTION BOLTS SHALL BE IN ACCORDANCE WITH ASTM A-307 OR A-325 F.
12. EXPANSION BOLTS AND LAG SCREWS SHALL HAVE A A MINIMUM EDGE DISTANCE OF 1" FOR LAGS AND 3" FOR EXPANSION BOLTS. PRE-DRILL HOLES IN LAG SCREWS.
13. VIBRATION ISOLATOR PADS SHALL BE PROVIDED BY THE A/C CONTRACTOR SO AS NOT TO CAUSE VIBRATION TO EXISTING SUB-STRUCTURE

REVISIONS

DATE

THIS DRAWING IS NOT VALID UNLESS SIGNED, SEALED AND DATED BY A REGISTERED PROFESSIONAL ENGINEER

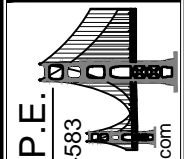

Joseph D. Hiller P.E.
Florida P.E. License # 74583

P.O. Box 290855
Port Orange, FL 32129
Phone: 386-248-1700
Email: hillereengineering@gmail.com

Aluminum Wall Braces

THE METAL SHOP
2541 W. Dunnellon Rd.
Dunnellon, FL 34434

THIS DRAWING AND ITS REPRODUCTIONS ARE THE PROPERTY OF THE ENGINEER AND MAY NOT BE REPRODUCED, PUBLISHED, OR USED IN ANYWAY WITHOUT THE WRITTEN PERMISSION OF THE ENGINEER

DATE 5/2/2024

SCALE AS NOTED

DRAWN BY J. HILLER

JOB NO.

SHEET

WB-1

1 OF 2

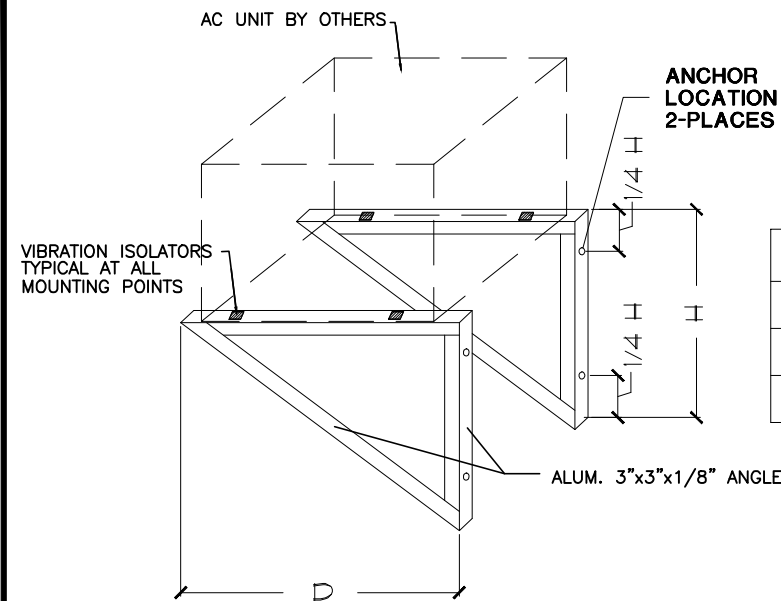

WALL BRACE SIZE SHART

PART No.	H DIM	D DIM
7-840	18"	24"
7-845	30"	36"
7-850	36"	48"

WALL BRACE REACTIONS TABLE

WALL MATERIAL	ALLOWABLE MOUNTING HEIGHT AT 186 MPH	MAXIMUM ALLOWABLE WEIGHT PER UNIT	UPLIFT	LATERAL	COMP.	MAXIMUM BENDING MOMENT
MASONRY BLK	30'	400 LBS	465*	903*	605*	685 FT-LB
CONCRETE 2500 psi MIN.	30'	425 LBS	465*	903*	642*	702 FT-LB
STEEL STUD	30'	350 LBS	465*	903*	498*	653 FT-LB
WOOD STUD	30'	350 LBS	465*	903*	498*	653 FT-LB

MAXIMUM DESIGN WIND PRESSURE	
WALL BRACE ATTACHED TO: MASONRY OR CONCRETE STRUCTURE	MAX WIND PRESSURE 90 PSF
WALL BRACE ATTACHED TO: STEEL STUD OR WOOD HOST STRUCTURE	MAX WIND PRESSURE 79.0 PSF

DESIGN WIND PRESSURE CALCULATED PER CHAPTER 29 OF ASCE 7-2022 FOR 186 MPH, CATEGORY II, EXPOSURE B, C & D
 CONTACT THE METAL SHOP FOR SITE SPECIFIC ENGINEERING FOR MOUNTING HEIGHTS ABOVE 30' AND FOR CATEGORY III OR IV BUILDINGS

FASTENERS:

STEEL

use Min. (2) 5/16"x 1 1/4" TEC Screw with self locking washer. Install additional blocking and/or studs as required to support wall brace. Achitect/Engineer of Record required for design of metal stud wall framing to support equipment loads from wall brace.

WOOD STUD

Use Min. (2) 1/2"x 3 3/4" Hex Head Lag screw W/ SS washer. 2 3/4" min. embed into stud. Install additional blocking and additional studs as required to support wall brace. Achitect/Engineer of Record required for design of wood frame structure to support equipment loads from wall brace.

INSTALLATION INSTRUCTIONS:

- Layout all parts as shown prior to assembly.
- Make sure at least 1 1/2" of condenser housing is resting on each wall stand.
- Mount equipment wall stands to host structure per anchor schedule. (Anchor hardware is not supplied with wall braces)
- Add vibration pads at condenser mounting points as specified by condenser manufacturer.
- Attach side of condensing unit to 1" wide G-90 Hot dipped galvanized - 16 Gauge metal hurricane strap with (2) #14x3/4" SS TEK screws. Attach opposite end of anchor strap to wall braces with minimum 1-#14x3/4" SS bolt. Hurricane anchors shall be installed taught, with no slack. Maximum spacing between TEK screws is 12".

CONCRETE

Min. (2) 3/8" dia x 3 3/4" SS Hilti Kwik Bolt or Equivalent with 2 1/2" minimum embedment into 2500 psi concrete.

MASONRY (grout filled cells)

Min. (2) 3/8" dia x 3 3/4" SS Hilti Kwik Bolt or Equivalent with 2 1/2" minimum embedment into solid filled cells

MASONRY (hollow cells)

Use 5/8" Galv. or SS all thread rod or hex bolt thru CMU when there are no filled cells. Use heavy duty or squre bearing washers at each end of bolt.

NOTES:

- ALL WALL BRACES SHALL BE FROM 6063-T5 ALUMINUM. 0.125"x3"x3' angle. MIG WELD ALL JOINTS AND SEAMS.
- YIELD STRENGTH OF STANDS SHALL BE 21 KSI AND CONFORM TO ASME AND ADM STANDARDS.
- WALL BRACES SHALL BE ANCHORED TO WALL TO RESIST WIND LOADS OF 186 MPH AS PER ASCE 7-22.
- ALL BOLTS SHALL BE STAINLESS STEEL A-304 OR EQUIVALENT, UNLESS OTHERWISE SPECIFIED.
- HURRICANE STRAPS SHALL BE 16 GA. G-90 HOT DIPPED GALVANIZED. METAL SHOP p/n 770 OR 771 RECOMMENDED. ANCHOR STRAP FOR A/C UNIT NOT INCLUDED.
- BOLTS SHALL HAVE A MINIMUM EDGE DISTANCE OF 1" IN ALUMINUM ANGLE BRACKET.
- WIND LOAD CALCULATIONS BASED ON THE TYPICAL SURFACE AREA OF A/C CONDENSOR OR HEAT PUMP UNITS.
- WELD FILLER SHALL MEET AWS STANDARDS FOR ALUMINUM AND SHALL HAVE A TENSILE STRENGTH OF 40 Ksi.
- ALL GALVANIZED OR PLAIN STEEL IN CONTACT WITH ALUMINUM SHALL HAVE PLASTIC OR RUBBER WASHERS, SPACES, OR BUSHINGS TO PREVENT GALVANIC CORROSION OF DISSIMILAR METALS.
- THE DESIGN OF THE WALL BRACES AS INDICATED, ANY DEVIATION INVALIDATES DESIGN AND ENGINEERING.

REVISIONS

DATE

THIS DRAWING IS NOT VALID UNLESS SIGNED, SEALED AND DATED BY A REGISTERED PROFESSIONAL ENGINEER

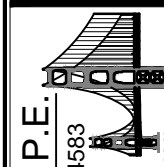

Joseph D. Hiller P.E.
 Florida P.E. License # 74583
 P.O. Box 290855
 Port Orange, FL 32129
 Phone: 386-248-1700
 Email: hillereengineering@gmail.com

Aluminum Wall Braces
 THE METAL SHOP
 2541 W. Dunnellon Rd.
 Dunnellon, FL 34434

THIS DRAWING AND ITS REPRODUCTIONS ARE THE PROPERTY OF THE ENGINEER AND MAY NOT BE REPRODUCED, PUBLISHED OR USED IN ANYWAY WITHOUT THE WRITTEN PERMISSION OF THE ENGINEER

DATE 5/2/2024

SCALE AS NOTED

DRAWN BY J. HILLER

JOB NO.

SHEET

WB-2

2 OF 2