

2018 EOQHA SUMMER SIZZLER CIRCUIT

LEVEL 1 Walk Trot Youth & Amateur Trail, Friday, August 3, 2018

JUDGES: Gigi Bailey, WI; Lisa Krohn, MN & Amy Watkins, OH

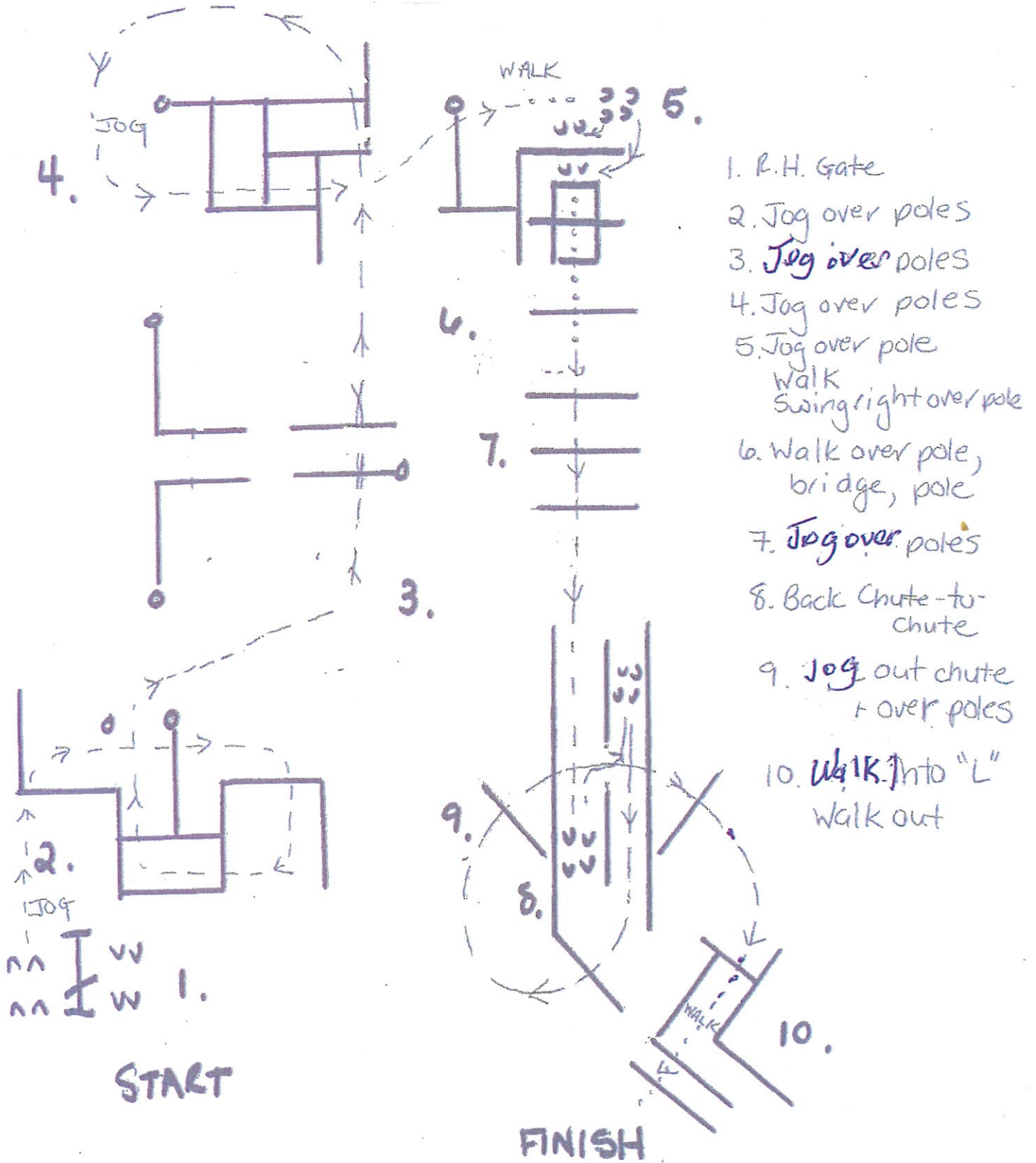

2018 EOQHA SUMMER SIZZLER CIRCUIT

ROOKIE, OPEN, YOUTH & AMATEUR, LEVEL 1 OPEN, YOUTH & AMATEUR Trail,
Friday, August 3, 2018

JUDGES: Gigi Bailey, WI; Lisa Krohn, MN & Amy Watkins, OH

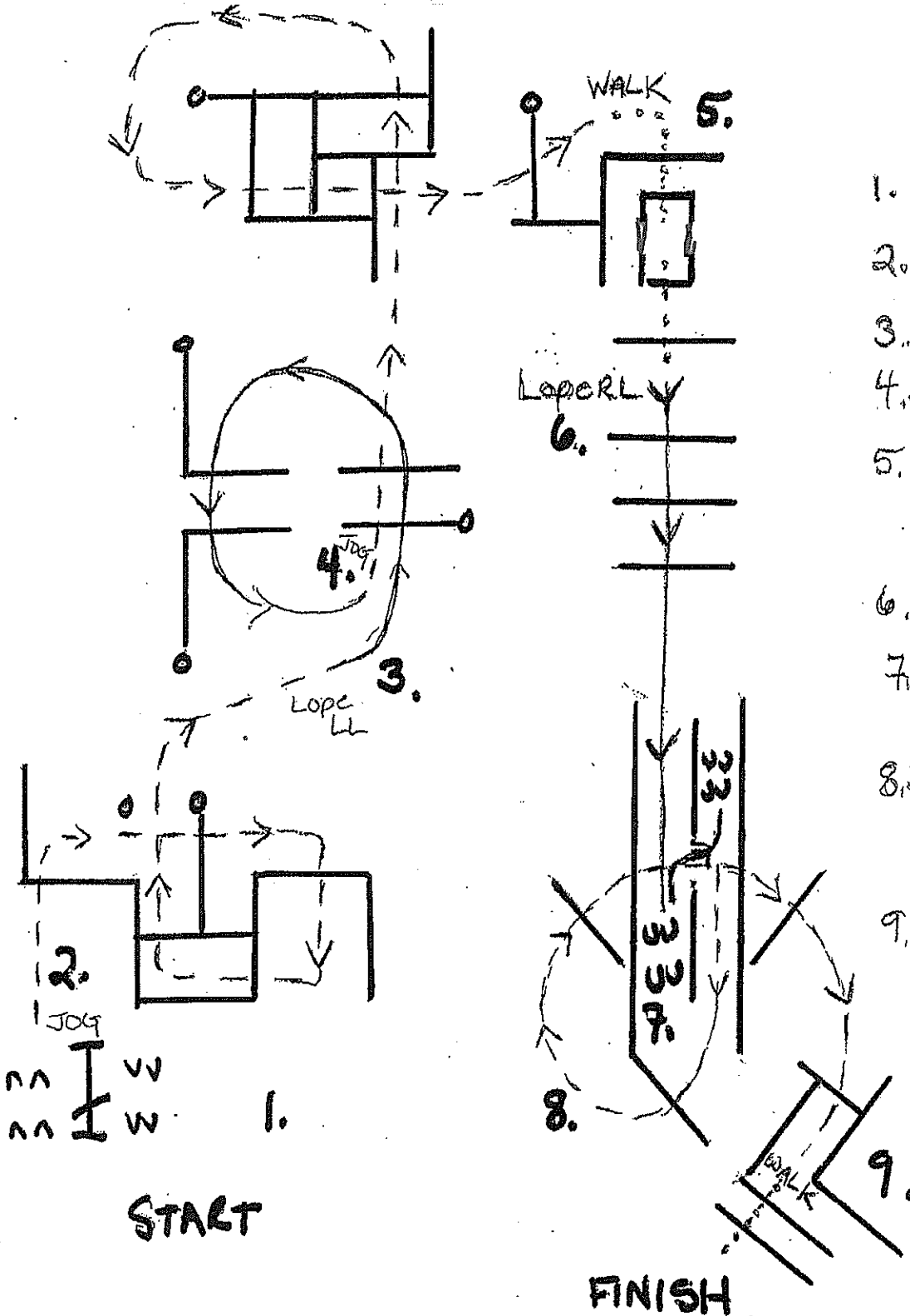

1. RH Gate
2. Jog over poles
3. LL Lope Poles
4. Jog over poles
5. Walk over bridge
6. RH Lope Poles
7. Back chute - to chute
8. Jog out of chute over poles.
9. Jog into "L", walk out.

START

FINISH

2018 EOQHA SUMMER SIZZLER CIRCUIT

OPEN. YOUTH, AMATEUR & SELECT AMATEUR Trail, Friday, August 3, 2018

JUDGES: Gigi Bailey, WI; Lisa Krohn, MN & Amy Watkins, OH

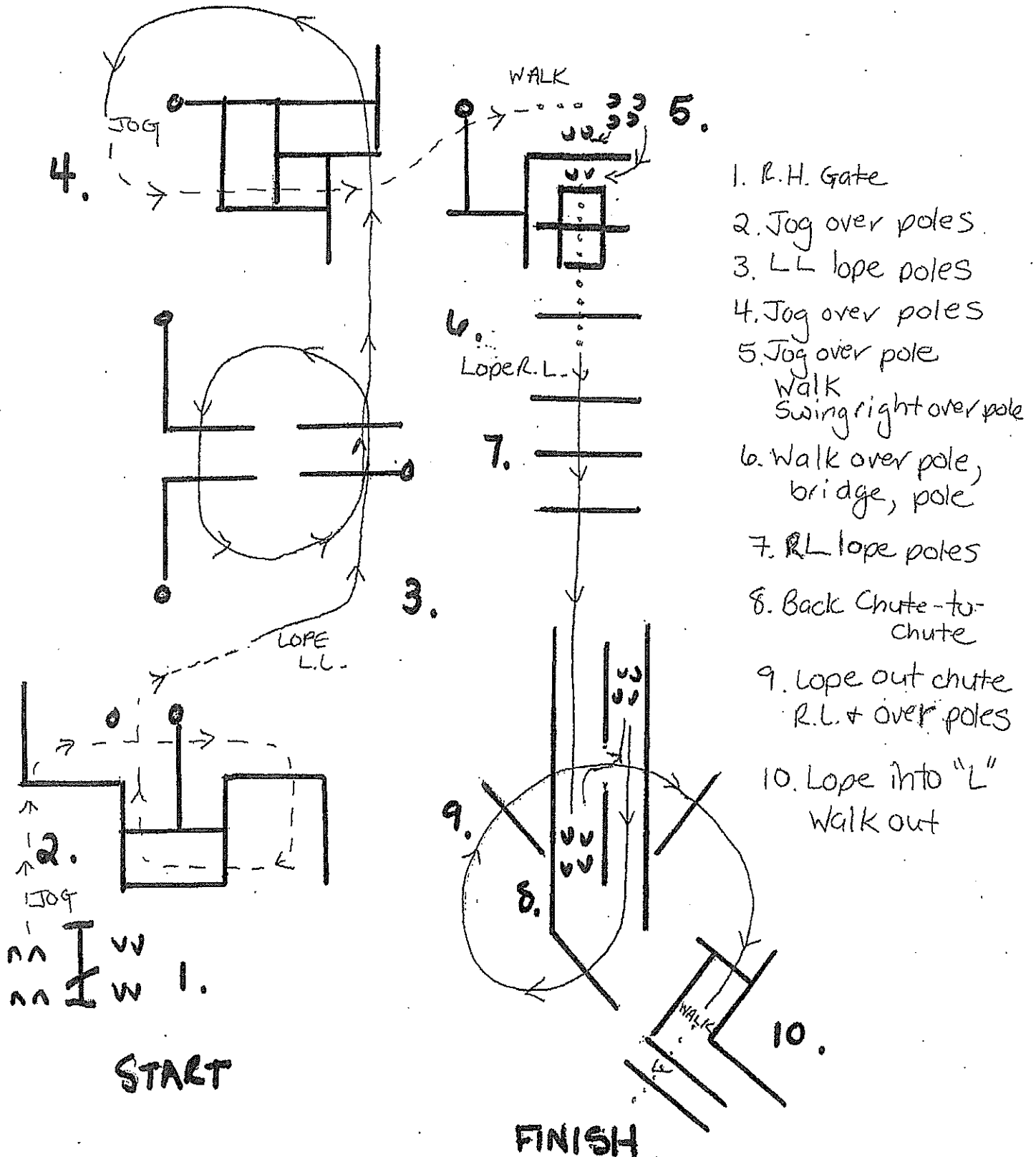

1. R.H. Gate
2. Jog over poles
3. L.L. lope poles
4. Jog over poles
5. Jog over pole
Walk
Swing right over pole
6. Walk over pole,
bridge, pole
7. R.L. lope poles
8. Back Chute-to-
chute
9. Lope out chute
R.L. + over poles
10. Lope into "L"
Walk out

2018 EOQHA SUMMER SIZZLER CIRCUIT

LEVEL 1 Walk Trot Youth & Amateur Trail, Sunday, August 5, 2018

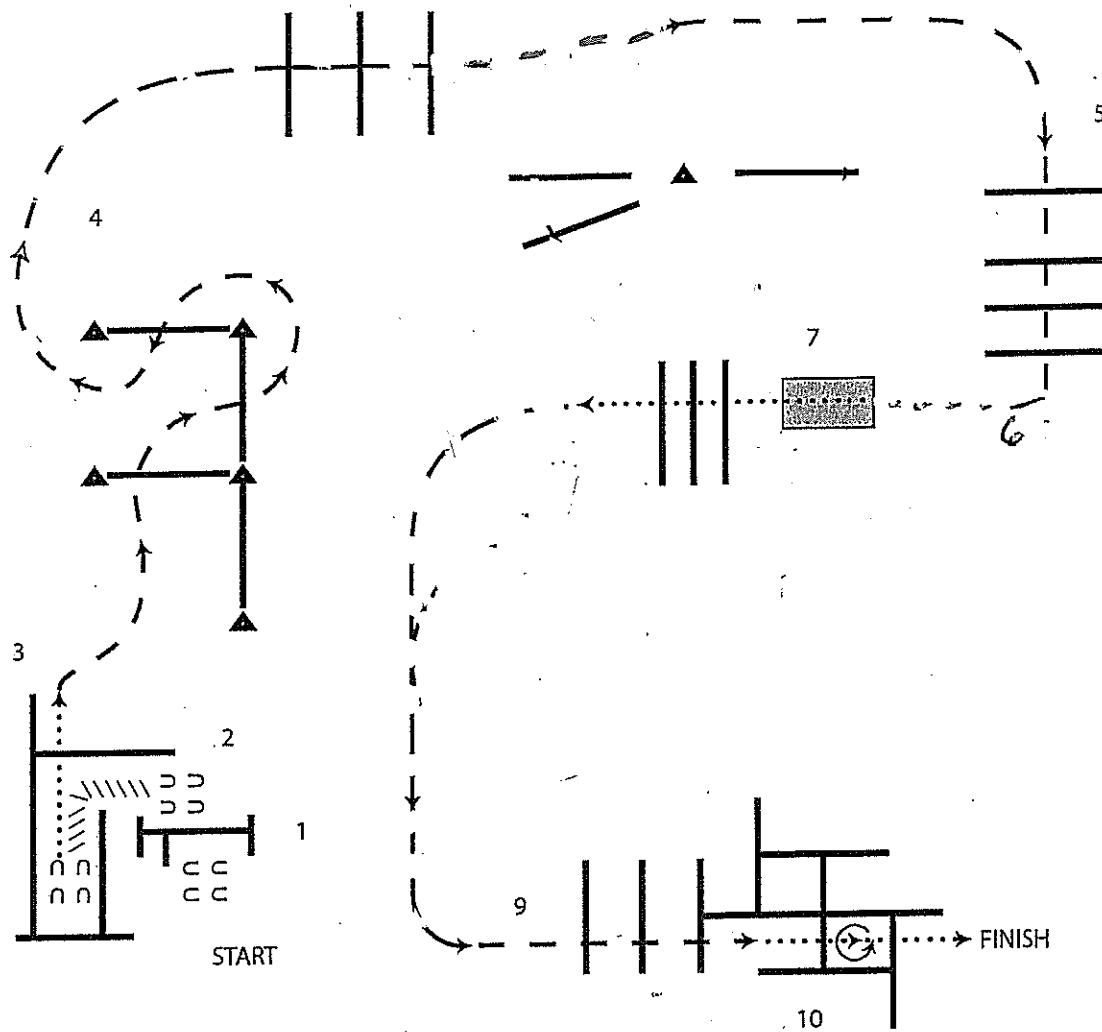

Key

.....	WALK
- - - - -	JOG
—————	LOPE
//////////	BACK
≈	CHANGE LEADS
▲	MARKER

Instructions

1. Start at gate. Work gate (right hand push), walk over pole.
2. Back the "L". Walk out over pole.
3. Jog serpentine over poles.
4. Jog over poles.
5. Break down to a jog over poles.
6. Break down to a walk
7. Walk over bridge and poles.
8. Jog and jog over poles.
9. Jog and jog over poles.
10. Walk into box, execute 360-degree turn to the left. Walk out of box to finish.

JUDGES: Kathy Boggetta, MI; Bruce Brown, KY & Scott Neuman, MT

2018 EOQHA SUMMER SIZZLER CIRCUIT

ROOKIE, OPEN, YOUTH & AMATEUR, LEVEL 1 OPEN, YOUTH & AMATEUR Trail,
 Sunday, August 5, 2018

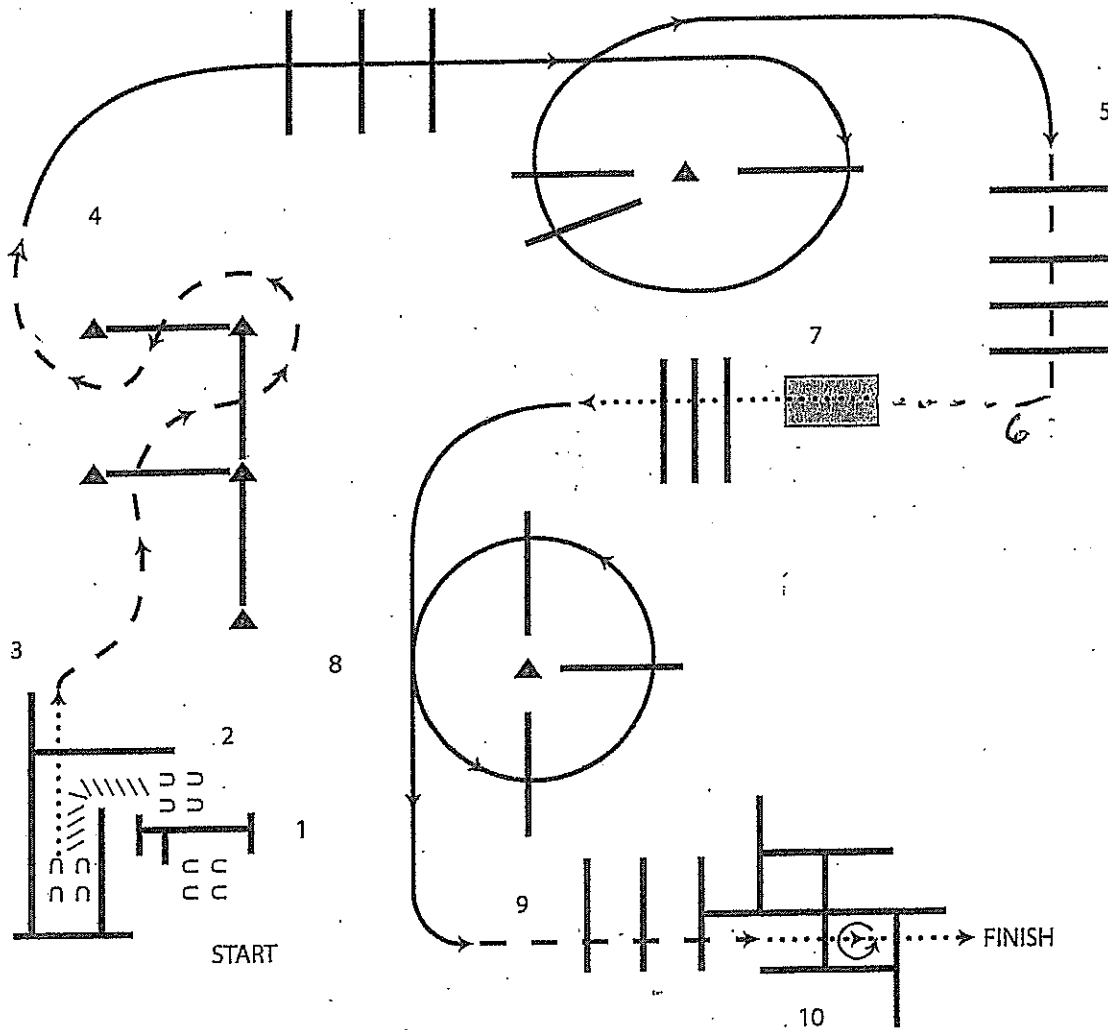

Key Instructions

.....	WALK
- - - - -	JOG
—————	LOPE
///////	BACK
≈	CHANGE LEADS
▲	MARKER

1. Start at gate. Work gate (right hand push), walk over pole.
2. Back the "L". Walk out over pole.
3. Jog serpentine over poles.
4. Lope over poles in right lead.
5. Break down to a jog over poles.
6. Break down to a walk
7. Walk over bridge and poles.
8. Lope in left lead over poles.
9. Break to a jog and jog over poles.
10. Walk into box, execute 360-degree turn to the left. Walk out of box to finish.

JUDGES: Kathy Boggetta, MI; Bruce Brown, KY & Scott Neuman, MT

2018 EOQHA SUMMER SIZZLER CIRCUIT

OPEN, YOUTH, AMATEUR & SELECT AMATEUR Trail, Sunday, August 5, 2018

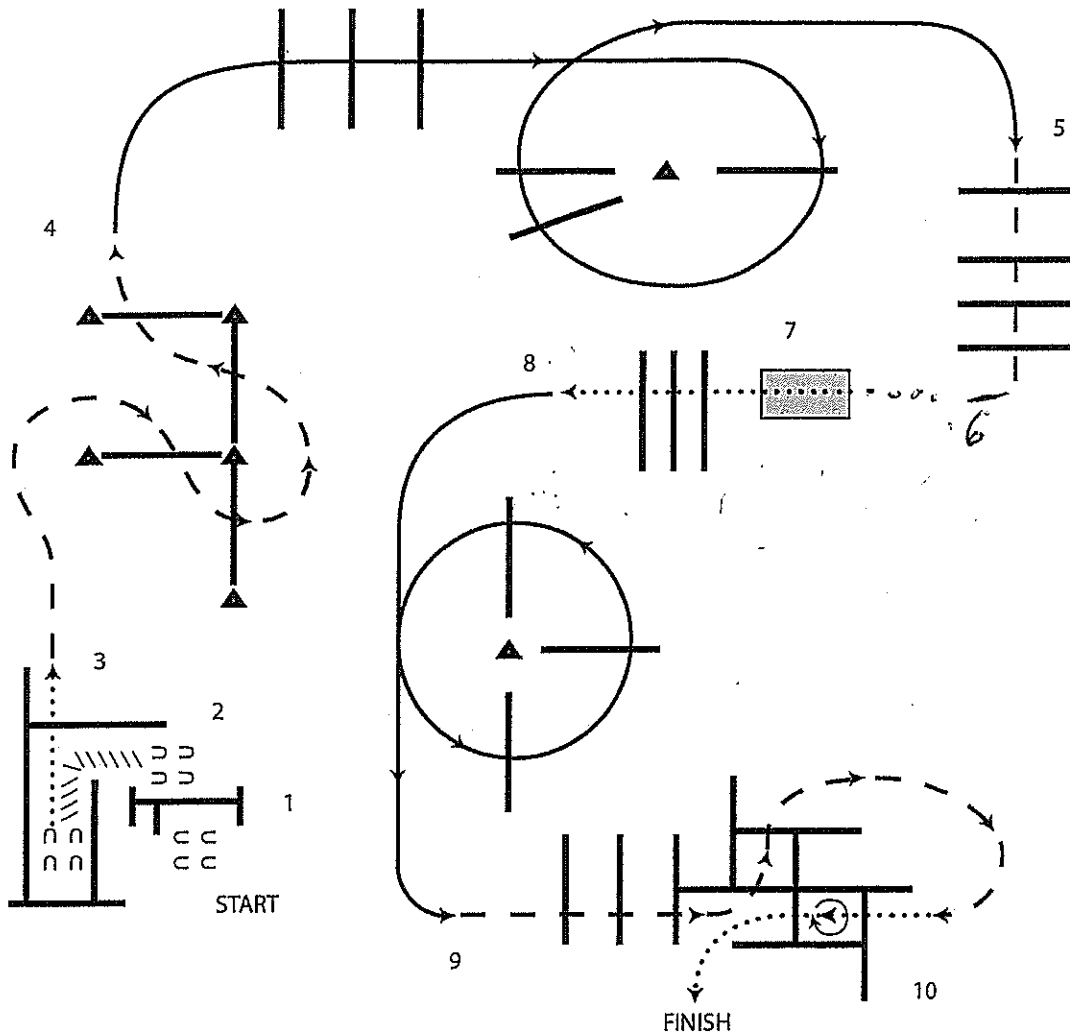

Key Instructions

.....	WALK
- - - - -	JOG
—————	LOPE
//////////	BACK
≈	CHANGE LEADS
▲	MARKER

1. Start at gate. Work gate (right hand push), walk over pole.
2. Back the "L". Walk out over pole.
3. Jog serpentine over poles.
4. Lope over poles in right lead.
5. Break down to a jog over poles.
6. *Break down to a walk.*
7. Walk over bridge and poles.
8. Lope in left lead over poles.
9. Break to a jog and jog over poles.
10. Walk into box, execute 360-degree turn to the right. Walk out of box to

JUDGES: Kathy Boggetta, MI; Bruce Brown, KY & Scott Neuman, MT