

### Limited Warranty

J & J Global, LLC (Seller) warrants to the original Buyer only, that each product will be free from defects in material and workmanship for a period of one (1) year from date of purchase. SELLER'S SOLE OBLIGATION AND BUYER'S EXCLUSIVE REMEDY UNDER THIS LIMITED WARRANTY SHALL BE THE REPAIR OR REPLACEMENT OF PARTS, WITHOUT CHARGE, WHICH ARE DEFECTIVE IN MATERIAL OR WORKMANSHIP. ANY PARTS AS DETERMINED BY THE SELLER WHICH HAVE BEEN MISUSED; ABUSED OR DAMAGED EITHER DIRECTLY OR INDIRECTLY FROM REPAIRS OR ALTERATIONS ATTEMPTED BY UNAUTHORIZED PERSON; IMPROPER MAINTENANCE, NEGLIGENCE OR ACCIDENT ARE NOT COVERED BY THIS LIMITED WARRANTY. This warranty does not apply to damage, heat-induced coloration changes, scratching or alteration due to normal use or weathering. To make a claim under this Limited Warranty, email [contact@ezreplacement.com](mailto:contact@ezreplacement.com) or visit [www.ezreplacement.com](http://www.ezreplacement.com) for warranty questions and claims.

#### Additional Limitations

THIS LIMITED WARRANTY DOES NOT APPLY TO ACCESSORY OR CONSUMABLE ITEMS RELATED TO THIS PRODUCT. ALL IMPLIED WARRANTIES SHALL BE LIMITED IN DURATION TO ONE (1) YEAR FROM DATE OF PURCHASE. IN NO EVENT SHALL SELLER BE LIABLE FOR ANY INCIDENTAL OR CONSEQUENTIAL DAMAGES, INCLUDING BUT NOT LIMITED TO LIABILITY FOR LOSS OF PROFITS, ARISING FROM THE SALE OR USE OF THIS PRODUCT.

If any provision of this Limited Warranty is for any reason held to be invalid or unenforceable, such provision shall not affect any other provision herein, this Limited Warranty shall be construed as if such invalid and/or unenforceable provision had never been contained herein.

This warranty gives you special legal rights, and you may also have other rights which vary from state to state.

This warranty contains the entire agreement between Seller and Buyer and supercedes any and all prior agreements, arrangements, or understandings between the parties relating to product warranty.

Due to ongoing product development the actual product or products may vary from the illustrations or photos shown within this manual.

For Manuals, Replacement Parts or Customer Service visit:  
[www.ezreplacement.com](http://www.ezreplacement.com)

This product is intended for residential, non-commercial use.

#### ⚠ WARNING

This product can expose you to lead, a chemical known to the state of California to cause cancer, birth defects and/or other reproductive harm. For more information go to [www.p65warnings.ca.gov/product](http://www.p65warnings.ca.gov/product)

**MADE IN CHINA**  
©2019 J & J Global, LLC  
Distributed By:  
J & J Global, LLC  
Carrollton, TX 75006

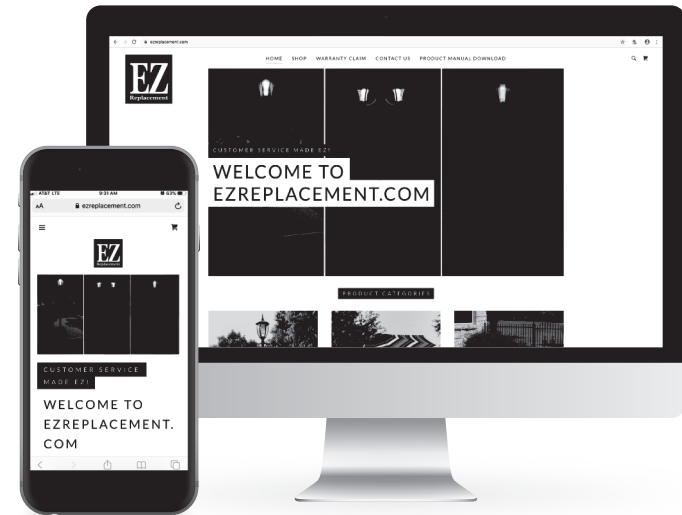

- User Friendly Interface
- Download Product Manuals
- Email your questions or concerns
- File Warranty Claim
- Follow-up within 24 Hrs
- Parts Ship within 48 Hrs.



Parts distribution made from our Carrollton, TX warehouse facility

## ATTENTION!

Please do not return this product to the retailer.  
If you are missing or have damaged parts please email  
[contact@ezreplacement.com](mailto:contact@ezreplacement.com) Or Call 877-477-2264



# Kambria Solar Lamp Post & Planter

SKU: 302022, 312022, 342022



**Read the instructions and precautions before use of this product**

**Please keep this instruction manual for future reference**

For warranty information, please refer to the back page of this instruction manual.

## Care Instructions

Clean any dirt and debris from the solar panels, the panels cannot recharge if the light is obstructed. Use a soft cloth to clean the panels. Do not use abrasives or chemicals that might scratch or damage the UV coating.

In a region where snow and ice are likely, and the light assembly is covered with snow for an extended period of time the batteries will require recharge for at least 8 hours.

Do not mix old batteries with new batteries.

Do not mix alkaline standard (Carbon-Zinc) or rechargeable (Nickel-Cadmium) batteries

### Recycling

Please dispose of batteries properly. Consult your local telephone listing for a battery recycling center in your area.



Ambient temperature  
maximal 40°C (105°F)



Do not dispose of  
batteries in  
household waste



Do not throw  
batteries into water!



Protect batteries  
against heat and fire  
risk of explosion



Recycling

# 7

## Battery Replacement

**Note:** The batteries in your solar lantern come pre-installed from the factory.

Twist the top of lantern head counter clock wise to remove solar panel housing.

Carefully lift the solar panel housing off the lantern head. The battery compartment is located under the solar panel.

Remove old battery.







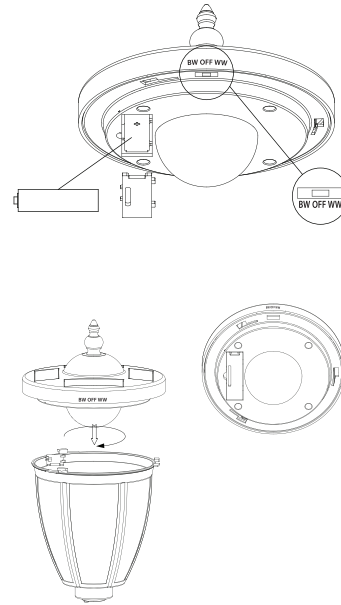

Replace old battery with 1 AA rechargeable Ni-MH battery. Reference polarity direction inside battery compartment.

Align tabs on lantern head with holes on solar panel housing. Twist solar panel housing clock wise to secure.

The rechargeable battery need to be fully charged before operating light assembly.



## Package Contents

<b>A</b> <b>x1</b> Lantern Body 	<b>B</b> <b>x1</b> Lantern Adapter 	<b>C</b> <b>x1</b> Decorative Post 	<b>D</b> <b>x1</b> Top Finial 
<b>E</b> <b>x1</b> Bottom Finial 	<b>F</b> <b>x1</b> Extension Post 	<b>G</b> <b>x1</b> Ground Stake 	<b>H</b> <b>x1</b> Planter Base 
<b>I</b> <b>x1</b> Wall Mount Hardware 			

Carefully remove the contents from the package. If any parts are missing do not attempt to use the product until they have been obtained and correctly installed.

# 1

## Instructions for First Time Use

Allow lantern to charge for at least 8 hours in full sunlight with the ON/OFF switch in the OFF position. The ON/OFF switch is located under the solar panel. The switch has three positions BW, OFF, and WW. Once the batteries are fully charged, set the switch to the BW for bright white light, or WW for warm white light. If the lantern doesn't turn on after initial charging, ensure battery is making contact with terminals.

# 4

Push stake into the ground leaving enough of the stake above ground to attach the extension post (F). Attach the extension post (F) to the ground stake (G). Next attach decorative post (C) to extension post (F). Attach the top finial (D) to decorative post (C). Attach the lantern adapter (B) on top of the scrolled arm of the decorative post and secure into place by tightening the bottom finial (E). Attach the lantern head (A) on top of the lantern adapter.

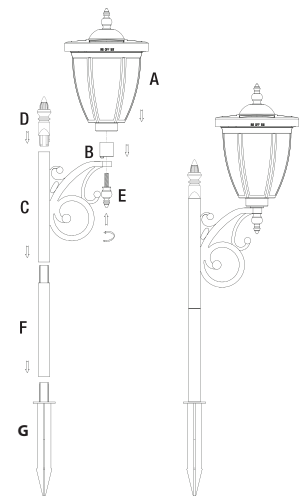

# 2

Attach the extension post (F) to the planter base (H). Next attach decorative post (C) to extension post (F). Attach the top finial (D) to decorative post (C). Attach the lantern adapter (B) on top of the scrolled arm of the decorative post and secure into place by tightening the bottom finial (E). Attach the lantern head (A) on top of the lantern adapter.

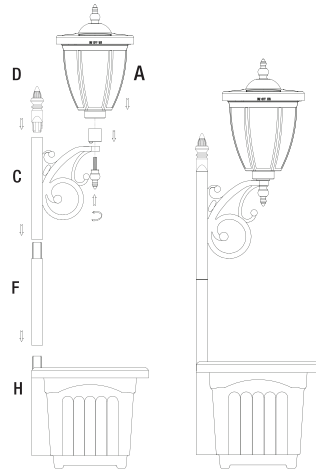

# 5

Attach planter base (H) to wall using wall mounting hardware (I). Drill hole into wall or surface, next push the wall anchor into hole. Screw two screws into the wall anchors leaving the screws out enough to attach planter base (H). Remove the top finial (D) and screw the last screw through decorative post (C) into wall anchor. Reattach top finial (D) to decorative post (C).

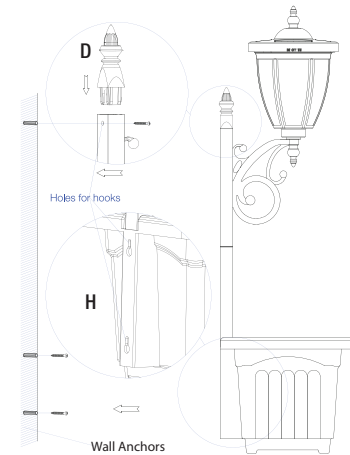

# 3

Ground mount stake provided for added stability when displaying in the yard.



**CAUTION:** To prevent product damage or personal injury from tip-over, lamp post planter base must be placed on a flat, level surface and be filled with an adequate amount of soil, rock or gravel. (Minimum 5-10lbs)

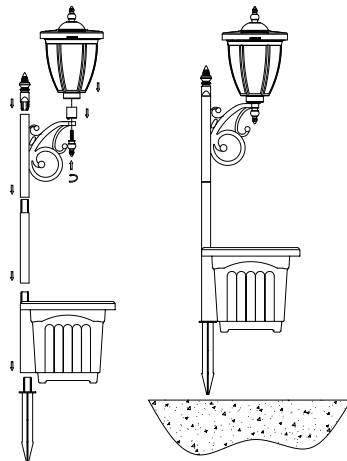

# 6

## Where To Place the Solar Light

Place the solar light in an area where it will receive direct sunlight for at least 8 hours per day. The number of hours the light is illuminated is directly proportional to the number of hours of sunlight it receives. If the light is placed in a shaded area, it will not be able to fully charge and its burn time will be limited. Do not place the light near other outdoor lighting like porch or streetlights. These may fool the sensor and keep the light from coming on, or cause it to turn off automatically.