

## Limited Warranty

J & J Global, LLC (Seller) warrants to the original Buyer only, that each product will be free from defects in material and workmanship for a period of one (1) year from date of purchase. SELLER'S SOLE OBLIGATION AND BUYER'S EXCLUSIVE REMEDY UNDER THIS LIMITED WARRANTY SHALL BE THE REPAIR OR REPLACEMENT OF PARTS, WITHOUT CHARGE, WHICH ARE DEFECTIVE IN MATERIAL OR WORKMANSHIP. ANY PARTS AS DETERMINED BY THE SELLER WHICH HAVE BEEN MISUSED; ABUSED OR DAMAGED EITHER DIRECTLY OR INDIRECTLY FROM REPAIRS OR ALTERATIONS ATTEMPTED BY UNAUTHORIZED PERSON; IMPROPER MAINTENANCE, NEGLIGENCE OR ACCIDENT ARE NOT COVERED BY THIS LIMITED WARRANTY. This warranty does not apply to damage, heat-induced coloration changes, scratching or alteration due to normal use or weathering. To make a claim under this Limited Warranty, email [contact@ezreplacement.com](mailto:contact@ezreplacement.com) or visit [www.ezreplacement.com](http://www.ezreplacement.com) for warranty questions and claims.

### Additional Limitations

THIS LIMITED WARRANTY DOES NOT APPLY TO ACCESSORY OR CONSUMABLE ITEMS RELATED TO THIS PRODUCT. ALL IMPLIED WARRANTIES SHALL BE LIMITED IN DURATION TO ONE (1) YEAR FROM DATE OF PURCHASE. IN NO EVENT SHALL SELLER BE LIABLE FOR ANY INCIDENTAL OR CONSEQUENTIAL DAMAGES, INCLUDING BUT NOT LIMITED TO LIABILITY FOR LOSS OF PROFITS, ARISING FROM THE SALE OR USE OF THIS PRODUCT.

If any provision of this Limited Warranty is for any reason held to be invalid or unenforceable, such provision shall not affect any other provision herein, this Limited Warranty shall be construed as if such invalid and/or unenforceable provision had never been contained herein.

This warranty gives you special legal rights, and you may also have other rights which vary from state to state.

This warranty contains the entire agreement between Seller and Buyer and supercedes any and all prior agreements, arrangements, or understandings between the parties relating to product warranty.

Due to ongoing product development the actual product or products may vary from the illustrations or photos shown within this manual.

**For Manuals, Replacement Parts or Customer Service visit:  
[www.ezreplacement.com](http://www.ezreplacement.com)**

This product is intended for residential, non-commercial use.

### ⚠ WARNING

This product can expose you to lead, a chemical known to the state of California to cause cancer, birth defects and/or other reproductive harm. For more information go to [www.p65warnings.ca.gov/product](http://www.p65warnings.ca.gov/product)

**MADE IN CHINA**  
©2020 J & J Global, LLC  
Distributed By:  
J & J Global, LLC  
Irving, TX 75038

**EZ**  
Replacement

[www.EZreplacement.com](http://www.EZreplacement.com)

# Customer Service Made EZ!

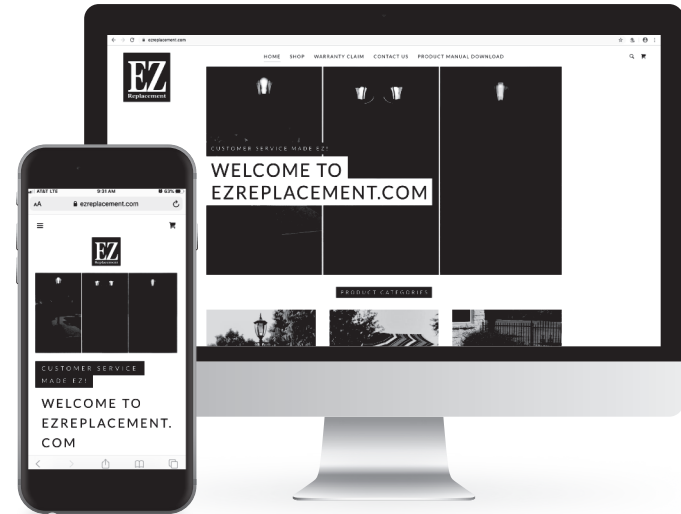

- User Friendly Interface
- Download Product Manuals
- Email your questions or concerns
- File Warranty Claim
- Follow-up within 24 Hrs
- Parts Ship within 48 Hrs.



Parts distribution made from our Carrollton, TX warehouse facility

## ATTENTION!

**Please do not return this product to the retailer.  
If you are missing or have damaged parts please email  
[contact@ezreplacement.com](mailto:contact@ezreplacement.com) Or Call 877-477-2264**



# Easy Dump Poly Wagon

Sku: 405016R



8

Align the handle (B) with steering yoke (E) and secure with bolt (L), washer (O) and nut (K).

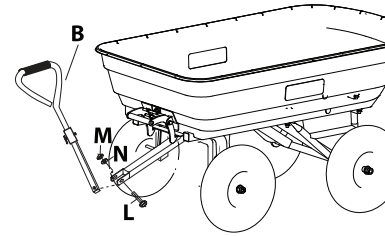

**TIP: Fully tighten all fasteners.**

**Read the instructions and precautions before use of this product**

**Please keep this instruction manual for future reference**

For warranty information, please refer to the back page of this instruction manual.

# 5

Push bolts (K) through the tray (A) with the slotted head on the inside of the tray (A).

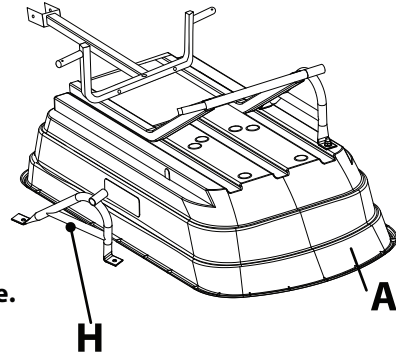

 **TIP: Do not tighten nuts at this time.**

# 6

Install the remaining rear axle bracket (H) with two bolts (K), washers (N) and nuts (M).

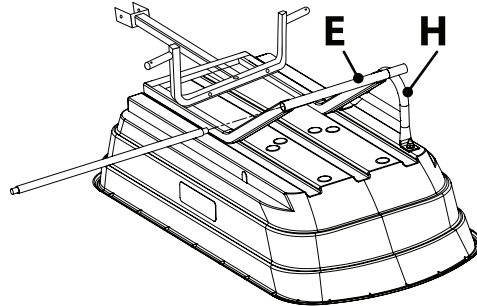





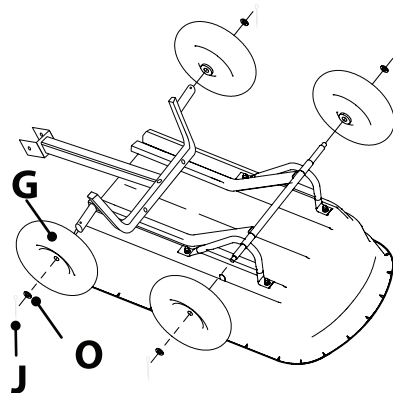



# 7

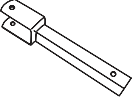

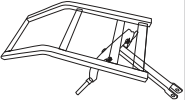

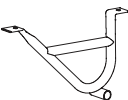
Slide one wheel (G) onto each axle end of the frame (E) with tire stems facing out. Secure with washers (O) and split pins (J). The rear axle (F) may need to be repositioned so that it protrudes through each wheel (G).



## Package Contents

<b>A</b> x2	Tray 	<b>B</b> x1	Handle 	<b>C</b> x1	Tow Hitch 	<b>D</b> x2	Lock (Latch) 
<b>E</b> x1	Frame 	<b>F</b> x1	Axle 	<b>G</b> x4	Wheel 	<b>H</b> x2	Rear Axle Bracket 
<b>I</b> x1	Quick Release Pin 	<b>J</b> x4	Split Pins 				

## Hardware Contents

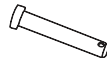
<b>K</b> x7	3/4 in. Slotted Truss Head Bolt 	<b>L</b> x1	2-3/8" in. Slotted Truss Head Bolt 
<b>M</b> x8	1/2 in. Hex Nut 	<b>N</b> x8	5/16 in. Flat Washer 
<b>O</b> x4	1/2 in. Flat Washer 	<b>P</b> x1	Cotter Pin 

# Exploded View

## ⚠ WARNING

**PINCH HAZARD** when opening and closing dump tray and when lifting and lowering handle  
**DUMPING INSTRUCTIONS:** To dump wagon pull up on latch and tip tray.  
**BEWARE** of cart movement  
**BEWARE** of handle on the ground being a trip hazard.  
**DO NOT** modify tool. Inspect frequently and replace damaged or worn components. Use tool only for labeled intended purpose.  
**NOT** intended for transportation of people or animals.  
**DO NOT** tow behind car or truck. **NOT INTENDED** for road use.  
**DO NOT** tow cart in excess of 5 MPH.  
**BEWARE** of making sharp turns. Load may tip over.  
**BEWARE** of positioning cart on uneven ground or inclined surfaces. Cart may tip over or move when unattended.

Read all instructions prior to assembly.

### Tools Required:

- Straight-head screwdriver
- 1/2 inch open-end wrench
- 3/4 inch open-end wrench
- or use adjustable wrench

Carefully remove the contents from the package. If any parts are missing do not attempt to use the product until they have been obtained and properly installed.

Read, understand and follow ALL instructions before using this product.



**DO NOT** over inflate the tires. Recommended pressure is 30 lbs. PSI. **WARNING!** Over inflation of tires can result in serious injury. Do not exceed 30 lbs. PSI tire pressure.

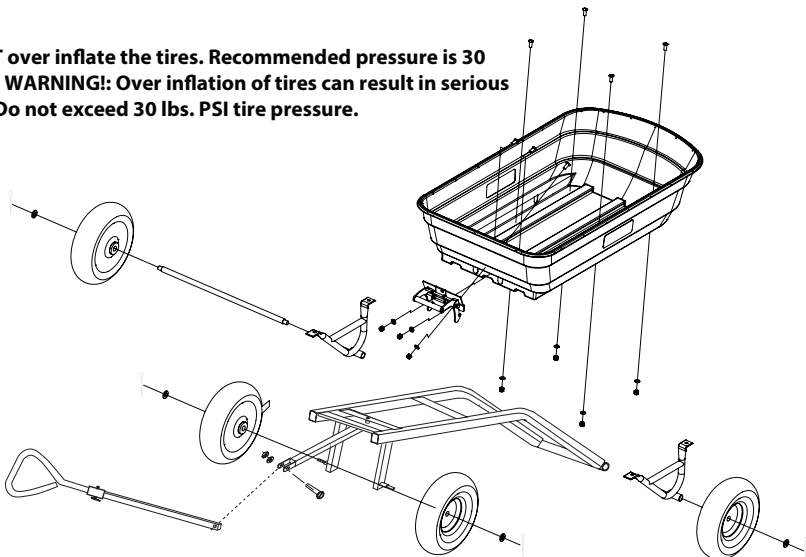

# 1

Secure Lock (latch) (D) using push bolts (K) through the tray (A) with slotted head on the inside of the tray (A) as shown in illustration. Secure the first two bolts (K) with washers (N) and nuts (M). Then, install the third bolt (K) with washer (N) and nut (M).

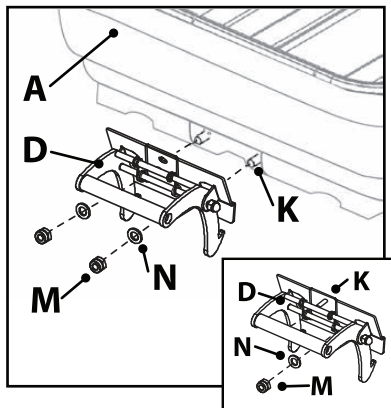

# 2

Push bolts (K) through the tray (A) with the slotted head on the inside of the tray (A). Secure one (1) of the rear axle brackets (H) with two bolts (K), washers (N) and nuts (M).

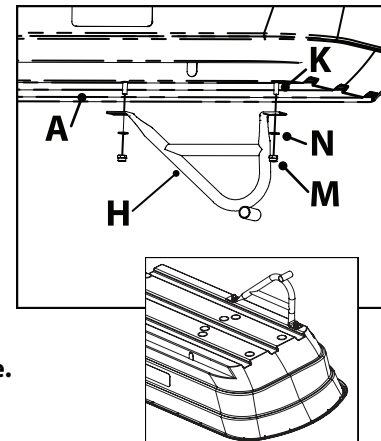

**TIP:** Do not tighten nuts at this time.

# 3

Align the frame (E) with the rear axle bracket (H) on the bottom of the tray (A).

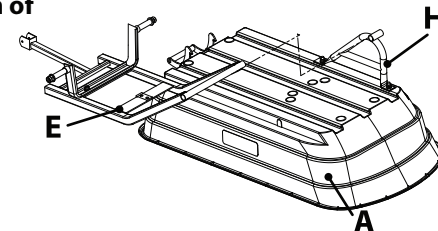

# 4

Slide the axle (F) through the frame (E) and the secured rear axle bracket (H).

