

4

3

2

1

| ITEM NO. | PART NUMBER | DESCRIPTION | QTY. |
|----------|-------------|--------------------------------------|------|
| 1 | M09-10925 | HITCH MATE FERRIS ISX800 BASE PLATE | 1 |
| 2 | P09-10085 | 2" HITCH RECEIVER | 1 |
| 3 | M09-10932 | HITCH MATE FERRIS ISX800 FRONT PLATE | 1 |
| 4 | H09-10167 | 3/8-16 X 1IN HEX HEAD FLANGE BOLT | 6 |
| 5 | P09-10162 | 5/8" HITCH PIN AND COTTER PIN | 1 |
| 6 | H09-10008 | 3/8"-16 FLANGE LOCKNUT | 6 |

| REVISIONS | | | | |
|-----------|------|------------------|------------|------|
| ZONE | REV. | DESCRIPTION | DATE | NAME |
| | A | ORIGINAL RELEASE | 12/23/2022 | JL |

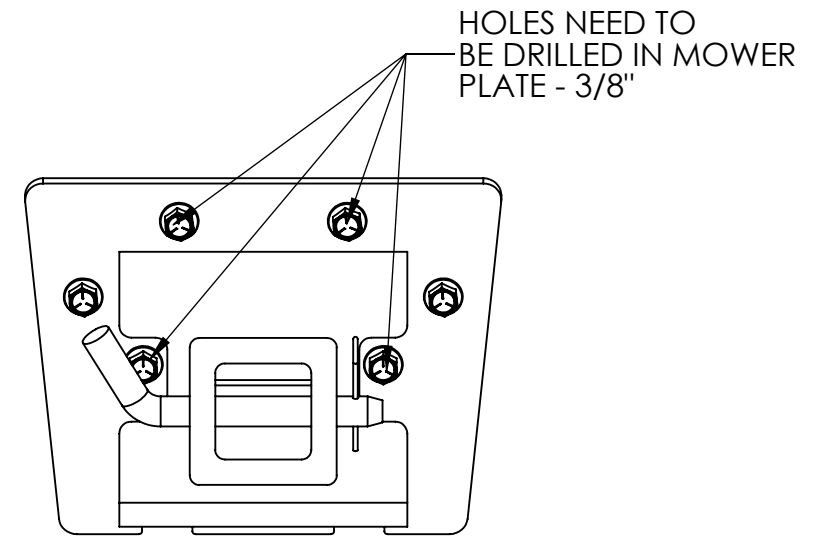
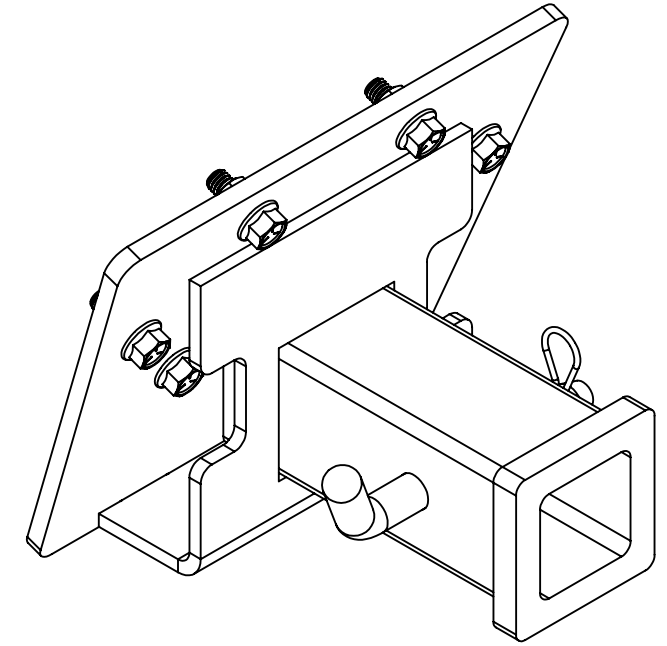
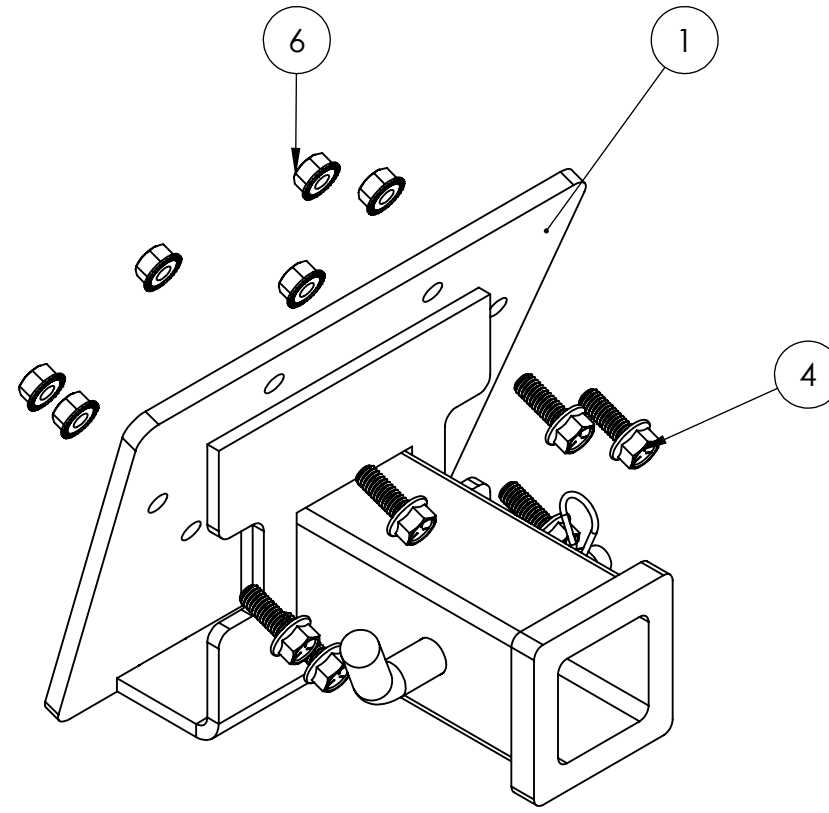

| | | | | | |
|--|---|----------------------|---|--------------------------|-----------------|
| DO NOT SCALE DRAWING | DIMENSIONS ARE IN INCHES TOLERANCES: ANGULAR: MACH ± 0.5 BEND ± 1 ONE PLACE DECIMAL ± .050 TWO PLACE DECIMAL ± .025 THREE PLACE DECIMAL ± .005 | 3RD ANGLE PROJECTION | TITLE: HITCH MATE, FERRIS, ISX, FRONT | PATENT PENDING | |
| PROPRIETARY AND CONFIDENTIAL THE INFORMATION CONTAINED IN THIS DRAWING IS THE SOLE PROPERTY OF DAWSON MANUFACTURING. ANY REPRODUCTION IN PART OR AS A WHOLE WITHOUT THE WRITTEN PERMISSION OF DAWSON MANUFACTURING IS PROHIBITED. | MATERIAL SEE BOM | FINISH | SIZE B | PART NO. HM-FER-ISX-F | REV A |
| | | | SCALE: 1:3 | WEIGHT: 14.17 lbs | SHEET 1 OF 1 |

4

3

2

1

B

B

A

A