

4

3

2

1

| ITEM NO. | PART NUMBER | DESCRIPTION | QTY. |
|----------|-------------|-----------------------------------------------------|------|
| 1 | M09-10566 | HITCH MATE FERRIS Z1 BOTTOM BRACKET | 1 |
| 2 | A09-10127 | HITCH MATE FERRIS Z1/Z2 TOP BRACKET WELDED ASSEMBLY | 1 |
| 3 | P09-10162 | 5/8" HITCH PIN AND COTTER PIN | 1 |
| 4 | H09-10228 | 5/16"-18 X 3.5" CARRIAGE BOLT | 2 |
| 5 | H09-10005 | 5/16" FLANGE LOCKNUT | 4 |
| 6 | H09-10002 | 5/16"-18 X 1" CARRIAGE BOLT | 2 |

| REVISIONS | | | | |
|-----------|------|------------------|-----------|------|
| ZONE | REV. | DESCRIPTION | DATE | NAME |
| | A | ORIGINAL RELEASE | 1/20/2021 | JL |

B



HITCH MATE MOUNTING LOCATION

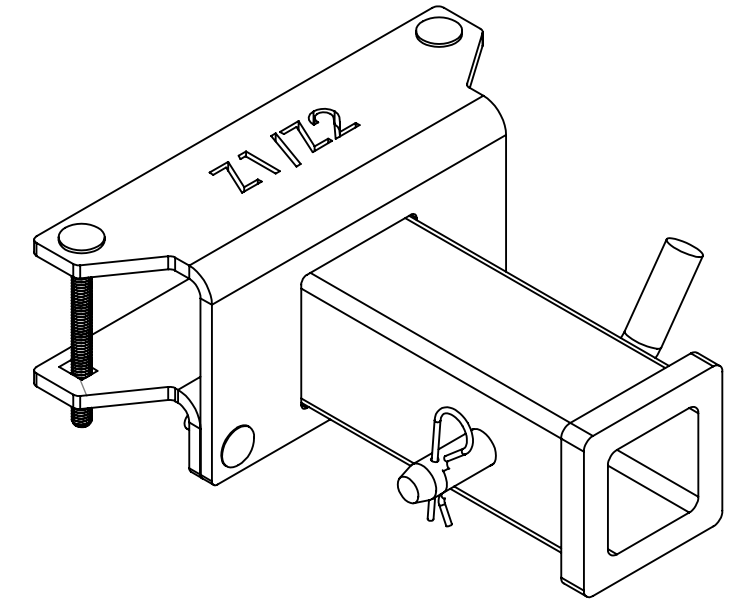
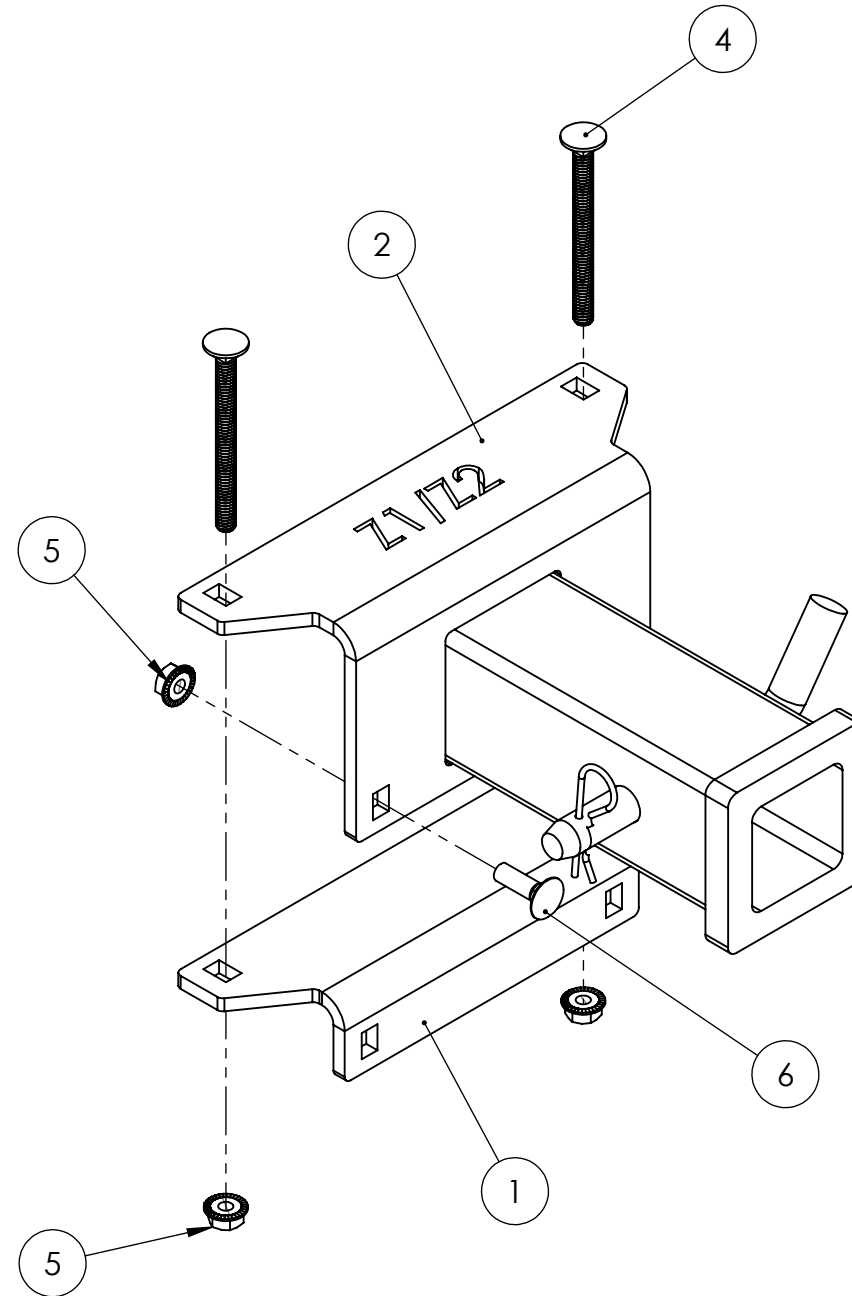

B

A

A



| | | | | | |
|--------------------------------------------------------------------------------------------------------------------------------------------------------------------------------------------------------------------------------------|---------------------------------------------------------------------------------------------------------------------------------------------------------------|----------------------|---------------------------------------------|----------------------------|--------------|
| DO NOT SCALE DRAWING | DIMENSIONS ARE IN INCHES TOLERANCES: ANGULAR: MACH ± 0.5 BEND ± 1 ONE PLACE DECIMAL ± .050 TWO PLACE DECIMAL ± .025 THREE PLACE DECIMAL ± .005 | 3RD ANGLE PROJECTION | TITLE: HITCH MATE FERRIS Z1 36" FRONT | PATENT PENDING | |
| PROPRIETARY AND CONFIDENTIAL THE INFORMATION CONTAINED IN THIS DRAWING IS THE SOLE PROPERTY OF DAWSON MANUFACTURING. ANY REPRODUCTION IN PART OR AS A WHOLE WITHOUT THE WRITTEN PERMISSION OF DAWSON MANUFACTURING IS PROHIBITED. | MATERIAL SEE BOM | FINISH | SIZE B | PART NO. HM-FER-Z1-36-F | REV A |
| | | | SCALE: 1:3 | WEIGHT: 10.01 lbs | SHEET 1 OF 1 |

4

3

2

1